

# Road and Rail Infrastructure II

---

## Edited book / Urednička knjiga

Publication status / Verzija rada: **Published version / Objavljena verzija rada (izdavačev PDF)**

Publication year / Godina izdavanja: **2012**

Permanent link / Trajna poveznica: <https://urn.nsk.hr/urn:nbn:hr:237:404199>

Rights / Prava: [In copyright](#) / [Zaštićeno autorskim pravom.](#)

Download date / Datum preuzimanja: **2024-12-26**

Repository / Repozitorij:

[Repository of the Faculty of Civil Engineering,  
University of Zagreb](#)



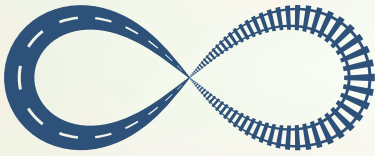

**CETRA**<sup>2012</sup>

2<sup>nd</sup> International Conference on Road and Rail Infrastructure  
7–9 May 2012, Dubrovnik, Croatia

## Road and Rail Infrastructure II

Stjepan Lakušić – EDITOR



Organizer  
University of Zagreb  
Faculty of Civil Engineering  
Department of Transportation



**CETRA<sup>2012</sup>**  
**2<sup>nd</sup> International Conference on Road and Rail Infrastructure**  
7–9 May 2012, Dubrovnik, Croatia

**TITLE**

Road and Rail Infrastructure II, Proceedings of the Conference CETRA 2012

**EDITED BY**

Stjepan Lakušić

**ISBN**

978-953-6272-50-1

**PUBLISHED BY**

Department of Transportation  
Faculty of Civil Engineering  
University of Zagreb  
Kačićeva 26, 10000 Zagreb, Croatia

**DESIGN, LAYOUT & COVER PAGE**

minimum d.o.o.  
Katarina Zlatec · Matej Korlaet

**COPIES**

600

A CIP catalogue record for this e–book is available from the National and University Library in Zagreb under 805372

Although all care was taken to ensure the integrity and quality of the publication and the information herein, no responsibility is assumed by the publisher, the editor and authors for any damages to property or persons as a result of operation or use of this publication or use the information's, instructions or ideas contained in the material herein.

The papers published in the Proceedings express the opinion of the authors, who also are responsible for their content. Reproduction or transmission of full papers is allowed only with written permission of the Publisher. Short parts may be reproduced only with proper quotation of the source.

Proceedings of the  
2<sup>nd</sup> International Conference on Road and Rail Infrastructures – CETRA 2012  
7–9 May 2012, Dubrovnik, Croatia

# Road and Rail Infrastructure II

EDITOR

Stjepan Lakušić

Department of Transportation

Faculty of Civil Engineering

University of Zagreb

Zagreb, Croatia

CETRA<sup>2012</sup>

2<sup>nd</sup> International Conference on Road and Rail Infrastructure

7–9 May 2012, Dubrovnik, Croatia

## ORGANISATION

### CHAIRMEN

Prof. Željko Korlaet, University of Zagreb, Faculty of Civil Engineering  
Prof. Stjepan Lakušić, University of Zagreb, Faculty of Civil Engineering

### ORGANIZING COMMITTEE

Prof. Stjepan Lakušić  
Prof. Željko Korlaet  
Prof. Vesna Dragčević  
Prof. Tatjana Rukavina  
Maja Ahac  
Ivo Haladin  
Saša Ahac  
Ivica Stančerić  
Josipa Domitrović

All members of CETRA 2012 Conference Organizing Committee are professors and assistants of the Department of Transportation, Faculty of Civil Engineering at University of Zagreb.

### INTERNATIONAL ACADEMIC SCIENTIFIC COMMITTEE

Prof. Ronald Blab, Vienna University of Technology, Austria  
Prof. Vesna Dragčević, University of Zagreb, Croatia  
Prof. Nenad Gucunski, Rutgers University, USA  
Prof. Željko Korlaet, University of Zagreb, Croatia  
Prof. Zoran Krakutovski, University Sts. Cyril and Methodius, Rep. of Macedonia  
Prof. Stjepan Lakušić, University of Zagreb, Croatia  
Prof. Dirk Lauwers, Ghent University, Belgium  
Prof. Giovanni Longo, University of Trieste, Italy  
Prof. Janusz Madejski, Silesian University of Technology, Poland  
Prof. Jan Mandula, Technical University of Kosice, Slovakia  
Prof. Nencho Nenov, University of Transport in Sofia, Bulgaria  
Prof. Athanassios Nikolaidis, Aristotle University of Thessaloniki, Greece  
Prof. Otto Plašek, Brno University of Technology, Czech Republic  
Prof. Christos Pyrgidis, Aristotle University of Thessaloniki, Greece  
Prof. Carmen Racanel, Technical University of Bucharest, Romania  
Prof. Stefano Ricci, University of Rome, Italy  
Prof. Tatjana Rukavina, University of Zagreb, Croatia  
Prof. Mirjana Tomičić–Torlaković, University of Belgrade, Serbia  
Prof. Brigita Salaiova, Technical University of Kosice, Slovakia  
Prof. Peter Veit, Graz University of Technology, Austria  
Prof. Marijan Žura, University of Ljubljana, Slovenia

## FOREWORD

The 2<sup>nd</sup> International Conference on Road and Rail Infrastructure – CETRA 2012 was organized by the University of Zagreb – Faculty of Civil Engineering, Department of Transportation. The Conference is held in Dubrovnik, Croatia. Dubrovnik is the “pearl of the Adriatic coast” and well known phrase related to it states “Those who seek paradise on Earth should come to Dubrovnik and see Dubrovnik”. The First International Conference on Road and Rail Infrastructure – CETRA 2010 is held in Opatija, Croatia. Great interest of participants in topics from the field of road and rail infrastructure during the conference CETRA 2010 in Opatija, where 140 presentations of papers from 29 countries took place, confirmed the soundness of Department for Transportation Engineering's decision on organizing such international event. Positive comments of the participants after the past Conference motivated the Department for Transportation Engineering, Faculty of Civil Engineering at University of Zagreb to continue the organization of such an event in the upcoming years (on a biennial basis).

In the year 2012, 2<sup>nd</sup> International Conference on Road and Rail Infrastructure – CETRA 2012 has been organized, with the intention of bringing together scientists and experts in the fields of road and railway engineering, giving them another opportunity to present the results of their researches, findings and innovations. Road and railway infrastructure is closely related, but scientific and professional gatherings covering both fields simultaneously are rarely being organized. The growing volume of traffic, both passenger and cargo, demands not only the development of the vehicles themselves (increasing their cargo capacity and speed), but also the timely construction and regular maintenance of infrastructure. It is exactly for this reason that the 2<sup>nd</sup> International Conference on Road and Rail Infrastructure – CETRA 2012 covers many areas: traffic planning & modelling, infrastructure projects, design of road and rail substructure and superstructure, construction and maintenance process, structural monitoring, urban transport infrastructures, application of recycled materials, innovation and new technology, environmental protection – noise and vibrations and, above all, education, which today has an increasingly important role.

This second Conference CETRA 2012 attracted a large number of papers from 39 countries and 52 Universities. More than 142 papers were presented at the Conference and are contained in these proceedings Road and Rail Infrastructure II. The papers are divided into the following sections: Education, Traffic planning and modelling, Infrastructure projects, Infrastructure management, Road infrastructure planning, Road pavement, Road maintenance, Structures and structural monitoring, Innovation and new technologies, Design of road and railways, Rail track structure, Environmental, Geotechnics, Integrated timetables, Urban transport planning and modelling, Urban transport infrastructure, Vehicles, Traffic safety.

The organizers of the Conference express their thanks to all Businesses and Institutions who helped in organization of this Conference. The Editor is grateful to all the authors for the excellent papers contributed to this book and wishes to thank the members of the International Academic Scientific Committee who participated in the review process. Our gratitude also goes to all the participants for their willingness to come to Dubrovnik and take part in CETRA 2012.

### THE EDITOR

Prof. dr. Stjepan Lakušić  
May, 2012.

## SPONSORS

### Under the Auspices of



UNIVERSITY OF  
**ZAGREB**

University of Zagreb  
Trg maršala Tita 14, 10000 ZAGREB, Croatia



MINISTRY OF MARITIME  
AFFAIRS, TRANSPORT  
AND INFRASTRUCTURE

Ministry of Maritime Affairs, Transport and Infrastructure  
Prisavlje 14, 10000 ZAGREB, Croatia



MINISTRY OF SCIENCE,  
EDUCATION AND SPORTS

Minister of Science, Education and Sports  
Donje Svetice 38, 10000 Zagreb, Croatia

### Golden Donors



BENTLEY  
[www.bentley.com/en-US/](http://www.bentley.com/en-US/)



GEOBRUGG  
[www.geobrugg.com](http://www.geobrugg.com)



CEMEX  
[www.cemex.hr](http://www.cemex.hr)

## Silver Donor



Department of Transportation Engineering  
Faculty of Civil Engineering  
University of Zagreb  
Kačićeva 26, 10000 Zagreb, Croatia

## Bronze Donors



Tensar International  
[www.tensar-international.com](http://www.tensar-international.com)



Chair for Rock Mechanics and Investigation Works  
Department of Geotechnical Engineering  
Faculty of Civil Engineering,  
University of Zagreb  
Kačićeva 26, 10000 Zagreb, Croatia

## Media Partners

**GRAĐEVINAR**

Journal of Croatian Association of Civil Engineers  
Berislavićeva 6, 10000 Zagreb, Croatia  
[www.hsgi.org/gradjevinar](http://www.hsgi.org/gradjevinar) · [gradjevinar@hsgi.org](mailto:gradjevinar@hsgi.org)

**ŽELJEZNICE 21**

Journal of Croatian Railway Engineering Association  
Petrinjska 89, 10000 Zagreb, Croatia · [hdzi@hznet.hr](mailto:hdzi@hznet.hr)



Journal for railway operators and suppliers  
[www.railwaygazette.com](http://www.railwaygazette.com) · [info@railwaygazette.com](mailto:info@railwaygazette.com)





# CONTENTS

FOREWORD .....	5
<b>KEYNOTE LECTURES</b>	
<b>INNOVATION WITHOUT IMPLEMENTATION EQUALS ZERO</b>	
Klaus Riessberger .....	19
<b>LIFETIME ENGINEERING FOR ROADS</b>	
Laszlo Gaspar .....	25
<b>ENERGY AND ENVIRONMENTAL ASPECTS OF HIGH-SPEED RAIL</b>	
Roderick A. Smith, Robert Watson, Jing Zhou .....	35
<b>NECESSITY TO SUPPORT THE FINANCING OF THE ROAD INFRASTRUCTURE</b>	
Christophe Nicodème .....	45
<b>1 EDUCATION</b>	
<b>RESEARCH ON COMPETENCES OF STUDENTS OF CIVIL ENGINEERING STUDIES IN THE FIELD OF ROAD CONSTRUCTION</b>	
Zlata Dolaček–Alduk, Sanja Dimter .....	59
<b>NEARLY 10 YEARS OF TEACHING RAILWAY SIMULATION AT THE VIENNA UNIVERSITY OF TECHNOLOGY</b>	
Katalin Jurecka .....	67
<b>2 TRAFFIC PLANNING AND MODELLING</b>	
<b>THE ROLE OF A POLICY MADE ROAD CATEGORISATION FOR SUSTAINABLE ROUTE NAVIGATION UNDER NORMAL AND CONGESTED TRAFFIC CONDITIONS</b>	
Koen De Baets .....	75
<b>BEHAVIORAL ANALYSIS OF DEPARTURE TIME DECISION CONSIDERING REDUNDANCY OF RAILROAD NETWORK</b>	
Kazuyuki Takada, Makoto Fujju, Shigeki Sugiyama .....	81
<b>TRUCK TRIP GENERATION RATES FOR DIFFERENT TYPES OF FACILITIES IN POLAND</b>	
Tomasz Kulpa .....	89
<b>CAPACITY VS. RELIABILITY IN RAILWAYS: A STOCHASTIC MICRO-SIMULATION APPROACH</b>	
Giovanni Longo, Giorgio Medeossi .....	97
<b>USING SIMULATION TO ASSESS INFRASTRUCTURE PERFORMANCE IN MULTICRITERIA EVALUATION OF RAILWAY PROJECTS</b>	
Giovanni Longo, Giorgio Medeossi, Elio Padoano .....	105
<b>3 INFRASTRUCTURE PROJECTS</b>	
<b>SPECIFICITIES OF PROJECT FOR RAILWAY LINE ON CORRIDOR VIII</b>	
Zoran Krakutovski, Darko Moslavac, Zlatko Zafirovski .....	115
<b>MODERNIZATION OF RAIL ROUTE 10 – KOSOVO RAILWAYS</b>	
Fitim Shala .....	123

## 4 INFRASTRUCTURE MANAGEMENT

<b>EFFICIENT AND CUSTOMER FRIENDLY LUGGAGE LOCKING</b> Bernhard Rüger, Hans-Christian Graf, Burkhard Stadlmann .....	133
<b>PUBLIC BUSES ON EMERGENCY LANES – A VERY SPECIAL USE OF A MOTORWAY IN AUSTRIA</b> Wolfgang Josef Berger.....	141
<b>THE POLISH SCIENTIFIC RESEARCHES ON ELECTRONIC TOLL COLLECTION AREA</b> Gabriel Nowacki.....	149
<b>THE FIRST EXPERIENCE OF ETC USAGE IN THE SILESIA REGION</b> Aleksander Stadkowski, Grzegorz Twardoch .....	155
<b>TRACK ACCESS CHARGE ALGORITHMS IN EU RAILWAYS: A DYNAMIC BENCHMARKING</b> Francesca Ciuffini, Stefano Ricci, Giulio Rocco Sitongia .....	161
<b>A NEW METHODOLOGY FOR ASSESSING THE PERFORMANCE OF ROAD SURFACE MARKINGS</b> Francesco Asdrubali, Cinzia Buratti, Elisa Moretti, Francesco D'Alessandro, Samuele Schiavoni.....	169
<b>A TENTATIVE TOLL MOTORWAY SOLUTION ON DURRES–TIRANA–ELBASAN ROAD CORRIDOR</b> Faruk Jusuf Kaba .....	177
<b>UNDERSTANDABLE, VISIBLE AND CLEAR INFORMATION TO THE DRIVER – DO WE KNOW HOW TO PROVIDE IT?</b> Uroš Brumec, Aleš Merkun, Nina Verzolak Hrabar .....	185

## 5 ROAD INFRASTRUCTURE PLANNING

<b>APPLICATION OF MULTICRITERIA ANALYSIS FOR SELECTION OF ALTERNATIVE IN THE ROAD PROJECTS</b> Aleksandar Glavinov, Zoran Krakutovski, Slobodan Ognjenovic, Katerina Mitkovska–Trendova .....	195
<b>STRATEGIC TRANSPORT INFRASTRUCTURE IN SOUTH EAST EUROPE: PLANNING EXPERIENCE AND PERSPECTIVES IN THE CONTEXT OF THE EUROPEAN TRANSPORT POLICY</b> Marios Miltiadou, Socrates Basbas, George Mintsis, Christos Taxiltaris, Anthi Tsakiropoulou .....	203
<b>HIGHWAY A8, SECTION ROGOVIČI–MATULJI, INFLUENCE OF GENERAL PUBLIC ON DESIGN SOLUTIONS</b> Nebojša Opačić, Tomislav Kraljić.....	213
<b>DECISION MAKING PROCESS ON THE ANTWERP OOSTERWHEEL LINK: LESSONS LEARNT</b> Dirk Lauwers.....	221

## 6 ROAD PAVEMENT

<b>PAVEMENT WIDENING ON ROAD CURVES</b> Željko Korlaet, Tomislav Dobrica, Ivica Stančerić .....	229
<b>VERTICAL DYNAMIC LOAD IMPACT ON THE PAVEMENT OF AN URBAN FRONT ENGINE BUS</b> Pablo Yugo Yoshiura Kubo, Cassio Eduardo Lima De Paiva.....	237
<b>PAVEMENT DESIGN OPTIMISATION CONSIDERING COSTS AND PREVENTIVE INTERVENTIONS</b> Adelino Ferreira, João Santos .....	243
<b>DEPENDENCY BETWEEN ROAD SURFACE GEOMETRY AND SKID RESISTANCE</b> Markus Weise, Wolfram Ressel.....	251
<b>RESISTANCE OF ASPHALT COURSES TO PERMANENT DEFORMATIONS IN THE FORM OF RUTS</b> Miroslav Šimun, Andrea Strineka, Tatjana Rukavina.....	259
<b>APPLICATION OF INFRARED CAMERA FOR QUALITY CONTROL DURING PAVING</b> Bojan Milovanovic, Josipa Domitrović, Tatjana Rukavina .....	267
<b>PAVEMENT SURFACES IN URBAN AREAS</b> Marijana Cuculić, Sergije Babić, Aleksandra Deluka–Tibljaš, Sanja Šurdonja .....	273
<b>PERMANENT DEFORMATIONS OF ASPHALT MIXTURES FROM PAVEMENT WEARING COURSES</b> Adrian Burlacu, Carmen Răcănel .....	281
<b>LABORATORY TESTS CONCERNING FATIGUE BEHAVIOR OF ASPHALT MIXTURES</b> Carmen Răcănel, Adrian Burlacu .....	287

<b>AIRPORT ASPHALT MIXTURES BEHAVIOUR TO FATIGUE AND PERMANENT DEFORMATION</b> Claudia Petcu, Carmen Răcănel .....	295
<b>THE INFLUENCE OF COMPACTION METHODS ON PROPERTIES OF ASPHALT MIXTURES: IMPACT COMPACTION VS. SLAB COMPACTION</b> Mizan Moges, Carsten Karcher .....	301
<b>BINDER MOBILIZATION IN RAP AND ITS CONTRIBUTION TO MIX PERFORMANCE</b> X. Carbonneau, F. Lubineau, B. Yvinec, Jean Paul Michaut .....	309
<b>PERMANENT DEFORMATION OF POLYMER MODIFIED BITUMEN</b> Vesna Oceljić Bulatović, Vesna Rek, Kristina Jurkaš Marković .....	317
<b>THE COMPARISON BETWEEN WHEEL TRACKING AND TRIAXIAL CYCLIC COMPRESSION TEST ON DIFFERENT ASPHALT MIXTURES</b> Nataša Zavrtnik, Roman Bašelj, Mitja Kozamernik, Goran Turk, Marjan Tušar .....	327
<b>CREEP RECOVERY BEHAVIOUR OF BITUMINOUS BINDERS—RELEVANCE TO PERMANENT DEFORMATION OF ASPHALT PAVEMENTS</b> Georges A. J. Mturi, Matsopole Nkgapele, Johan O'Connell .....	335
<b>EVALUATION OF THE EFFECT OF AGGREGATES ANGULARITY ON THE SURFACE PROPERTIES OF HOT MIX ASPHALT</b> Amir Onşori, Burak Sengoz, Ali Topal, Cagri Gorkem .....	343
<b>COMPARISON OF LOW-TEMPERATURE BITUMINOUS MIXTURES SELECTED PROPERTIES</b> Josef Zak, Jiri Vavricka, Silvia Stefunkova .....	351
<b>RESEARCH OF ASPHALT LAYERS BONDING IN LITHUANIAN PAVEMENT</b> Audrius Vaitkus, Donatas Čygas, Alfredas Laurinavičius, Viktoras Vorobjovas, Rita Kleizienė .....	357
<b>ANALYSIS OF THE FLEXIBLE PAVEMENTS TRANSITIONS USING FINITE ELEMENT METHOD</b> Cassio Eduardo Lima De Paiva, Leandro Cardoso Trentin .....	365
<b>COMPARISON OF THE LABORATORY AND FIELD TESTS USED FOR PAVEMENT DESIGN</b> Lenka Sevelova, Jaroslav Hauser, Alice Kozumplikova .....	373
<b>7 ROAD MAINTENANCE</b>	
<b>WORLD-CLASS PERFORMANCE BASED MAINTENANCE CONTRACTS – RECENT TRENDS</b> Pekka Pakkala, Antti Talvitie .....	383
<b>PREDICTION MODEL FOR THE COST OF ROAD REHABILITATION AND RECONSTRUCTION WORKS</b> Jelena Čirilović, Nevena Vajdić, Goran Mladenović, Cesar Queiroz .....	389
<b>PRINCIPLES OF ROAD MAINTENANCE BASED ON PERFORMANCE CRITERIA</b> Mihai Dicu, Carmen Răcănel, Adrian Burlacu, Ştefan Marian Lazăr, Claudia Petcu .....	397
<b>EFFECTIVE ROAD MAINTENANCE WORKS PLANNING</b> Ján Mikolaj, Ľubomír Pepucha, Peter Časnocha, Ľuboš Remek .....	405
<b>MICRO-SURFACING ON FRENCH HIGHWAYS: RECENT SUCCESSFUL EXPERIENCES</b> Jean-Etienne Urbain, Mario Medved, Eric Layerle, Ivan Kolaric .....	413
<b>ON A NOVEL OPTIMISATION MODEL AND SOLUTION METHOD FOR TACTICAL RAILWAY MAINTENANCE PLANNING</b> Franziska Heinicke, Axel Simroth, Roberto Tadei .....	421
<b>SMART MAINTENANCE AND ANALYSIS OF RAILWAY TRANSPORT INFRASTRUCTURE (SMART RAIL)</b> Kenneth Gavin, Irina Stipanović Oslaković, Marko Vajdić, Goran Puž, Velimir Sporčić .....	429
<b>8 STRUCTURES AND STRUCTURAL MONITORING</b>	
<b>EXTENDING LIFE OF CONCRETE BRIDGE DECKS THROUGH EARLY DETERIORATION DETECTION BY NDE METHODS</b> Nenad Gucunski, Ali Maher, Hamid Ghasemi .....	439
<b>VIADUCT DESIGNS ON THE SECTION OF THE PAN-EUROPEAN CORRIDOR X IN SOUTH SERBIA</b> Slavica Vucetic-Abinun .....	447

FINAL DESIGN FOR WIDENING OF BRIDGE OVER NISAVA RIVER, ON THE RIGHT CARRIAGEWAY OF THE MOTORWAY E80: NIŠ–DIMITROVGRAD Jasmina Damnjanović, Igor Stefanović .....	455
SPECIFIC FEATURES OF A5 HIGHWAY–BRIDGE OVER RIVER DRAVA Vladimir Moser, Sanja Dimter, Ivana Barišić .....	461
ÖBB RAILWAY BRIDGE CONSTRUCTION – CHALLENGES IN USING THE EUROCODES Thomas Petraschek .....	469
SOME EXPERIENCES IN PRODUCTION OF CONCRETE MIXES DESIGNS FOR CONSTRUCTION OF CORRIDOR X IN SERBIA Zoran Grdić, Gordana Topličić–Ćurčić, Nenad Ristić, Iva Despotović .....	477
DEMAND FOR WAYSIDE TRAIN MONITORING SYSTEMS IN THE NETWORK OF SLOVENIAN RAILWAYS Andreas Schöbel, Danilo Vek .....	485
THERMIC INTERACTION BETWEEN CONTINUOUS WELDED RAIL AND THE BRIDGE Otto Plasek, Vlastislav Salajka, Michal Mrozek, Milos Bratka .....	491
EXPERIENCES FROM BRIDGE SCOUR INSPECTIONS BY USING TWO ASSESSMENT METHODS ON 100 RAILWAY BRIDGES Damir Bekić, Eamon McKeogh, Igor Kerin, Stephen Hand, Gillian Bruton .....	499
<b>9 RAIL INFRASTRUCTURE PLANNING</b>	
THE IMPORTANCE OF INDUSTRIAL TRACK IN RAILWAY INFRASTRUCTURE Waldemar Alduk, Sanja Dimter, Zlata Dolaček–Alduk .....	509
TOURIST POTENTIAL OF THE INDUSTRIAL RAILWAY NETWORK IN BARANYA Sanja Lončar–Vicković, Dina Stober, Zlata Dolaček–Alduk .....	517
OVERVIEW OF THE RAILWAY LINE ZAGREB–RIJEKA AS PART OF THE SPATIAL–TRAFFIC STUDY OF THE PRIMORJE–GORSKI KOTAR COUNTY AND THE CITY OF RIJEKA Stjepan Kralj .....	523
ONE MODEL FOR RAIL INFRASTRUCTURE PROJECTS SELECTION Dragana Macura, Rešad Nuhodžić, Nebojša Bojović, Nikola Knežević .....	533
APPLICATION OF MULTICRITERIA OPTIMIZATION IN THE RAILWAY LINE DESIGNING AT THE GENERAL PROJECT LEVEL Ljubo Marković, Ljiljana Milić Marković, Goran Čirović .....	539
BENEFITS OF A MANAGED ENVIRONMENT ON A LARGE INFRASTRUCTURE PROJECT Silvano Paolo Gritti, Andrea Amante, Armando Manes .....	547
APPLICATION OF MULTICRITERIA ANALYSIS FOR SELECTION OF ALTERNATIVE IN THE ROAD PROJECTS Aleksandar Glavinov, Zoran Krakutovski, Slobodan Ognjenovic, Katerina Mitkovska–Trendova .....	557
STRATEGIC TRANSPORT INFRASTRUCTURE IN SOUTH EAST EUROPE: PLANNING EXPERIENCE AND PERSPECTIVES IN THE CONTEXT OF THE EUROPEAN TRANSPORT POLICY Marios Miltiadou, Socrates Basbas, George Mintsis, Christos Taxiltaris, Anthi Tsakiropoulou .....	565
INFRASTRUCTURAL PRIORITIES OF MODERNIZATION IN RUSSIA Stanislav Alexandrovich Stepanov .....	575
USING RAILWAY SIMULATION AS A BASIS FOR INFRASTRUCTURE PLANNING – FOCUSING ON STRUCTURAL CHANGES AT TRAIN STATION EXITS Katalin Jurecka .....	579
COMPARATIVE ANALYSIS OF ALTERNATIVE FIXED TRACK TECHNOLOGIES FOR THESSALONIKI AIR–LINK CONNECTION Panagiotis Papaioannou, Alexandros Deloukas, Ioannis Politis, Manos Vougioukas .....	587
AIRPORT ACCESS INFRASTRUCTURE CRITICAL ISSUE OF THE INTERMODAL CHAIN Antonín Kazda .....	595
RAILWAY AS THE SOLUTION FOR ROAD CONGESTIONS Darja Šemrov, Aleš Pavšek, Franc Zemljič .....	601

## 10 RAIL TRACK STRUCTURE

<b>LIGHT RAIL TRACK STRUCTURE COMPARATIVE ANALYSIS</b> Mirjana Tomičić–Torklavić, Vladan Branković.....	609
<b>TECHNICAL PARAMETERS FOR SELECTION OF ELASTIC RAIL FASTENINGS</b> Tatjana Simić.....	617
<b>FWD APPLICATION TO RAILWAY TRACK–BED LAYERS CHARACTERIZATION</b> Simona Fontul, Govind Kamlesh, Francesca De Chiara, Eduardo Fortunato.....	625
<b>TRANSITION ZONES ON THE RAILWAY TRACK – OVERVIEW</b> Marko Vajdić, Irina Stipanović Oslaković, Stjepan Kralj.....	633
<b>INFLUENCE OF USPS ON THE QUALITY OF TRACK GEOMETRY IN TURNOUT</b> Miroslava Hruzikova, Otto Plasek, Jaroslav Smutny, Richard Svoboda.....	641
<b>CONTINUOUSLY WELDED RAIL (CWR) TRACK BUCKLING AND SAFETY CONCEPTS</b> Sanjin Albinović, Mirna Hebib–Albinović.....	649
<b>EFFECTS OF TRAM TRACK DESIGN AND EXPLOITATION PARAMETERS ON GAUGE DIVERGENCE</b> Stjepan Lakušić, Maja Ahac, Ivo Haladin.....	657
<b>ARC WELDING OF GROOVED RAILS – MANUAL METAL ARC WELDING VERSUS FLUX CORED ARC WELDING</b> Stjepan Lakušić, Tamara Džambas, Maja Ahac, Ivo Haladin, Ivan Duvnjak.....	665

## 11 INNOVATION AND NEW TECHNOLOGY

<b>INNOVATIVE MATERIALS FOR SUSTAINABLE RAILWAY TRACKS – ECOTRACK</b> Stjepan Lakušić, Dubravka Bjegović, Ana Baričević, Ivo Haladin.....	675
<b>GREEN TRACK – ENVIRONMENTAL PERFORMANCE EVALUATION FOR 'GREEN' TRAMWAY SUPERSTRUCTURE</b> Paul Steckler, Brigitte Klug, Florian Gasser, Werner Wehr.....	683
<b>ENERGY CONSUMPTION INDUCED BY OPERATION PHASE OF RAILWAYS AND ROAD INFRASTRUCTURES</b> Alex Coiret, Pierre–Olivier Vandanjon, Romain Bosquet, Agnès Jullien.....	693
<b>RUCONBAR – GREENING THE MARKET OF NOISE PROTECTION SOLUTIONS</b> Stjepan Lakušić, Dubravka Bjegović, Ivo Haladin, Ana Baričević, Marijana Serdar.....	701
<b>FEM DRIVEN DESIGN PROCESS OF INNOVATIVE INTERMODAL TRUCK–RAIL SOLUTION</b> Wieslaw Krason, Tadeusz Niezgodą, Krzysztof Damaziak.....	709

## 12 ENVIRONMENTAL PROTECTION

<b>DYNAMIC EFFECT OF MOVING LOAD ON ASPHALT PAVEMENT</b> Jozef Melcer, Gabriela Lajčaková.....	719
<b>THE FEASIBILITY OF PIEZOELECTRIC ENERGY HARVESTING FOR CIVIL APPLICATIONS</b> Simon C. Bos.....	727
<b>RAIL ROUGHNESS MEASUREMENT AND ANALYSIS IN FRAME OF RAIL VEHICLE PASS-BY NOISE MEASUREMENTS</b> Stjepan Lakušić, Ivo Haladin, Ante Jukić, Nikola Andrašić, Petar Piplica.....	733
<b>LOW NOISE PAVEMENTS: AVAILABLE SOLUTIONS</b> Jean Paul Michaut.....	739
<b>INTEGRATED NOISE PROTECTION BARRIERS AND SOLAR POWER PLANT ON RIJEKA BYPASS</b> Boris Huzjan, Sanjin–Velebit Pešut.....	745
<b>ROAD TRAFFIC NOISE MODELING AT ROUNDABOUTS</b> Saša Ahac, Vesna Dragčević.....	751
<b>MODELLING THE IMPACT OF TRAFFIC ON QUALITY OF LIFE: SCENARIO EVALUATION FOR THE CITY OF GHENT</b> Dominique Gillis, Dirk Lauwers, Luc Dekoninck, Dick Botteldooren.....	757

### 13 GEOTECHNICS

AN ALTERNATIVE ANALYSIS FOR DEVELOPING THE SWELLING MODEL FOR EXPANSIVE CLAYS Moshe Livneh .....	765
EXPRESSWAY CONSTRUCTION ON YOUNG KARST IN BRECCIA (VIPAVA VALLEY, SLOVENIA) Martin Knez, Tadej Slabe .....	773
LARGE EMBANKMENT NEAR SUHAREKĚ ON THE KOSOVO MOTORWAY Verica Gjetvaj, Ljerka Bušelić .....	781
THE STUPICA TUNNEL – ROCKFALL PROTECTION Meho Saša Kovačević, Antonia Mirčeta, Lovorka Librić .....	789
A COMPARISON OF 2D AND 3D NUMERICAL SIMULATION FOR TUNNEL EXCAVATION ACCOMPANIED BY MEASUREMENT RESULTS Mario Bačić, Danijela Marčić, Meho Saša Kovačević .....	797
PROTECTION MEASURES AGAINST DEBRIS FLOWS, USING FLEXIBLE RING NET BARRIERS IN THE TEUFELSKADRICH, GERMANY Roland Bucher, Corinna Wendeler, Vjekoslav Budimir .....	805

### 14 INTEGRATED TIMETABLES

PERIODIC TIMETABLE CONCEPT FOR THE BOSNIA AND HERZEGOVINA RAILWAY NETWORK Dženet Ljevo, Andreas Schöbel .....	815
ON THE DELIVERY ROBUSTNESS OF TRAIN TIMETABLES WITH RESPECT TO PRODUCTION REPLANNING POSSIBILITIES Sara Gestrelus, Martin Aronsson, Malin Forsgren, Hans Dahlberg .....	823
INTEGRATED PERIODIC TIMETABLE IN HUNGARY – EXPERIENCES, HELP FOR VISION Viktor Borza, János Földiák .....	831
TECHNICAL AND TECHNOLOGICAL PRECONDITIONS FOR IMPLEMENTATION OF INTEGRATED TIMETABLE IN REGIONAL PASSENGER TRANSPORT WITH THE REPUBLIC OF SLOVENIA Tomislav Josip Mlinarić, Tihomir Pleša, Ivica Ljubaj .....	841
TECHNICAL AND TECHNOLOGICAL PRECONDITIONS FOR IMPLEMENTATION OF THE INTEGRATED TIMETABLE IN REGIONAL PASSENGER TRANSPORT IN THE REPUBLIC OF HUNGARY Tomislav Josip Mlinarić, Denis Lauš, Melkior Vilić .....	847
INTEGRATED PERIODIC TIMETABLE SCHEDULING – TOWARDS AN INTEGRATED TIMETABLE ACROSS CENTRAL EUROPE Stefan Walter .....	855
THE DEVELOPMENT OF THE INTEGRATED PERIODIC TIMETABLE IN AUSTRIA Helmut Uttenthaler .....	863
DEVELOPMENT OF PERIODIC TIMETABLE IN THE CZECH REPUBLIC Vít Janoš, Karel Baudyš .....	869
IMPLEMENTATION OF PERIODIC TIMETABLE IN REGIONAL PASSENGER TRANSPORT OF REPUBLIC OF CROATIA Tomislav Josip Mlinarić, Tihomir Pleša, Inda Balagić .....	875

### 15 URBAN TRANSPORT PLANNING AND MODELLING

INFRASTRUCTURE INVESTMENTS AND ITS IMPACT ON REGIONAL ECONOMY – EVIDENCE FROM TWO CASE STUDIES AS STARTING POINT FOR A PLANNING TOOL Roman Klementschtiz .....	883
THE IMPACT OF THE IMPLEMENTATION OF GREEN WAVE IN THE TRAFFIC LIGHT SYSTEM OF A TRAMWAY LINE – THE CASE OF ATHENS TRAMWAY Christos Pyrgidis, Martha Chatziparaskeva .....	891
PROGRAM FOR DEVELOPMENT OF BICYCLE TRAFFIC IN THE CITY OF ZAGREB Marijan Ključarić, Krunoslav Tepeš, Hrvoje Pilko .....	899

<b>MODEL FOR A SHORT – TERM FORECAST OF VEHICLES IN BITOLA TOWN</b> Vaska Atanasova, Lidija Markovik .....	907
<b>E–MOBILITY IN URBAN AREAS AND THE IMPACT OF PARKING ORGANISATION</b> Harald Frey, Anna Mayerthaler, Paul Pfaffenbichler, Tadej Brezina .....	915
<b>DEMOGRAPHIC MODEL 'AGE–COHORT' FOR MODELLING OF URBAN MOBILITY IN LONG TERM</b> Zoran Krakutovski .....	923
<b>APPROACH TO DEALING WITH THE TRANSPORT DEMAND MANAGEMENT IN CITIES WITH THE REVIEW ON CITY OF ZAGREB</b> Marko Slavulj, Davor Brčić, Ljupko Šimunović .....	929
<b>NEW TRANSPORTATION SYSTEM OF THE CITY OF DUBROVNIK</b> Damir Pološki, Željko Stepan, Igor Majstorović .....	937
<b>TRAFFIC LIGHTS ON CONSECUTIVE INTERSECTIONS AND PEDESTRIAN CROSSINGS ALONG LINEAR SETTLEMENTS LOCATED ON NATIONAL ROADS</b> Alina Burlacu, Mihai Dicu, Valentin Anton .....	945
<b>REQUIREMENTS FOR HIGH QUALITY CYCLING INFRASTRUCTURE DESIGN</b> Tadej Brezina, Nikolaus Ibesich, Martin Niegl, Helmut Lemmerer .....	953
<b>CRITICAL PLANNING AND DESIGN PARAMETERS FOR GARAGES</b> Rudolf Eger .....	961
<b>FUTURE TRANSPORT NETWORK OF THE CITY OF DUBROVNIK</b> Igor Majstorović, Mario Njegovec, Ana Rigo .....	969
<b>16 URBAN TRANSPORT INFRASTRUCTURE</b>	
<b>SPEED AS AN ELEMENT FOR DESIGNING ROUNDABOUTS</b> Hrvoje Pilko, Davor Brčić, Nikola Šubić .....	981
<b>DEVELOPMENT OF METRO ZAGREB PROJECT</b> Davorin Kolić .....	989
<b>MINI–ROUNDABOUTS IN URBAN AREAS</b> Sanja Šurdonja, Sergije Babić, Aleksandra Deluka–Tibljaš, Marijana Cuculić .....	997
<b>DESIGN ELEMENTS OF MODERN ROUNDABOUTS</b> Mario Njegovec, Željko Stepan, Ana Rigo .....	1005
<b>RENAISSANCE OF THE RAILWAY CONNECTION TRSTENA–NOWY TARG</b> Juraj Muzik, Zuzana Gocálová, Andrej Villim, Janka Šestáková, Lubomír Pepucha .....	1013
<b>17 VEHICLES</b>	
<b>BOARDING ACCESSIBILITY TO TRAIN VEHICLES FOR EVERYONE</b> Bernhard Rüger, Goran Simic .....	1019
<b>RAILWAY INTERIORS IN ORDER TO REDUCE DWELL TIME</b> Bernhard Rüger .....	1027
<b>VIRTUAL ROAD MODELS FROM DYNAMIC MEASUREMENTS</b> Kai Tejkl, Wolfram Ressel .....	1033
<b>IDEA AND TESTS OF THE RAILWAY WAGON WITH A ROTATABLE PLATFORM FOR INTERMODAL TRANSPORT</b> Tadeusz Niezgodza, Wieslaw Krason, Wieslaw Barnat .....	1041
<b>18 TRAFFIC SAFETY</b>	
<b>SAFETY MEASURES ON RAIL AND ROAD ENGINEERING STRUCTURES – A COMPARATIVE ASSESSMENT</b> Christos Pyrgidis, Fotini Kehagia .....	1051
<b>CONTROL SYSTEM FOR TRAINS IN MOVEMENT</b> Dobrinka Atmadzhova, Emil Dimitrov, Nencho Nenov .....	1059



<b>ENSURING SAFETY OF OPERATION BY AUTOMATIC MEASUREMENT OF ROLLING STOCK WHEELS GEOMETRY</b> Janusz Madejski.....	1067
<b>THE ANALYSIS OF TRAFFIC ACCIDENTS ON LITHUANIAN STATE ROADS</b> Stanislav Mamčič, Henrikas Sivilevičius.....	1077
<b>ANALYSIS OF ROAD TRAFFIC SAFETY AFTER THE CONSTRUCTION OF THE FULL PROFILE OF THE RIJEKA–ZAGREB MOTORWAY</b> Željko Denona, Boris Huzjan, Tatjana Matković.....	1085
<b>INTEGRATING HUMAN FACTOR IN THE ANALYSIS OF THE INTERACTION 'TRAM – CAR DRIVERS'</b> Fatiha Moutchou, Abdelghani Cherkaoui, El Miloudi El Koursi.....	1093
<b>METHODOLOGY FOR SAFETY PERFORMANCE ASSESSMENT OF HIGHWAY INFRASTRUCTURE – ISSUES, RECENT APPLICATIONS AND FUTURE DIRECTIONS</b> Bhagwant Persaud.....	1101
<b>DRIVER'S DISTRACTION AND INATTENTION PROFILE IN TYPICAL URBAN HIGH SPEED ARTERIALS</b> Eleni Misokefalou, Nikolaos Eliou.....	1109
<b>SIGHT DISTANCE TESTS AT ROAD INTERSECTIONS WITH UNFAVOURABLE ANGLES</b> Ivica Stančerić, Željko Korlaet, Vesna Dragčević.....	1117
<b>THE BEHAVIOUR OF PASSIVELY SAFE ROADSIDE COLUMNS IN IMPACT WITH VEHICLES</b> Višnja Tkalčević Lakušić, Stjepan Lakušić.....	1129
<b>ACCIDENTS AT THE LEVEL CROSSINGS IN LITHUANIAN RAILWAYS</b> Inesa Gailienė, Vaidas Ramūnas, Kęstutis Skerys.....	1139
<b>ANTI–SLIP RUBBER BASE FOR PEDESTRIAN CROSSINGS</b> Marko Hoič, Igor Keser.....	1147
<b>A MODEL FOR ASSESSING COLLISION RISK ON AUTOMATIC LEVEL CROSSINGS</b> Mohamed Ghazel.....	1151
<b>SAFETY OF TRAFFIC ON RAIL-ROAD CROSSINGS WITH SPECIAL REVIEW OF EU DIRECTIVES ON TRAFFIC SAFETY- PROPOSALS FOR IMPROVEMENTS</b> Georg–Davor Lisicin, Igor Novačić.....	1159
<b>AUTHOR INDEX.....</b>	1169

## KEYNOTE LECTURES



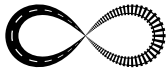

## INNOVATION WITHOUT IMPLEMENTATION EQUALS ZERO

**Klaus Riessberger**

*Graz University of Technology, Institute of Railway Engineering*

The birthday of railways can be set on the 15th September, 1830 when the first long distance railway line was inaugurated. This is now 182 years back. The advent of the new transportation technology, however, was not a flash-light innovation, but the result of an already long history of new ideas, produced more or less independently. Guided vehicles on “tram rails” were long known in mining activities, pulled by animals or even man-power. Turnouts were first patented in 1776 (by John Curr), the same year when James Watt introduced his (stationary) steam engine. A working steam locomotive was put on show by Richard Trevethick in 1804, working on a cock-type infrastructure, because nobody believed in friction as a reliable means for propelling and braking.

All these developments were combined in George and Robert Stephenson’s project of a long distance railway from Manchester to Liverpool. The famous Rainhill experiment on 6th October, 1829 was only a confirmation of their convictions that the innovations MUST work. One only can admire the foresighted decision makers and financiers to enter this undertaking without having been presented all the balance sheets of the future, including life-cycle-costing and pension funds considerations.

But in 1830 the railway was far from perfect. Speeds were slow and complaints of health danger were loudly voiced. Braking was a technical problem throughout the 19th century, riding comfort was limited to 2-axle wagons covered in a cloud of smoke and steam. Train operation was hazardous as long as no signals and respective communication existed.

All these items underwent developments, driven by innovation. Railway history is full of pioneering ideas in all fields of railway engineering, which have contributed to the success of railways to become the leading transportation mode in Europe and overseas as well. Railway was “high-tech” of the 19th and the first half of the 20th century.

In accordance with the engineering progress also the legal conditions were developed to guarantee the national status and later also the international conformity. The agreement on “Technical Conformity (Technische Einheit)” from 1888 opened the doors for the highly needed interoperability amongst the national railway systems in Europe with its many nationally influenced isolated standards.

When electric traction became feasible the agreement on a common feeding system (15 kV, 16 2/3 Hz) was signed in 1912. Unfortunately not all European states of the time ratified, which causes problems until this date. But the development of the 3-phase technology 20 years ago allowed to resolve this question in a satisfactory manner. Multi voltage locomotives are common technology in our days.

Much more complex is the development of a train operation control system for Europe. The “European Railway Transport Management System (ERTMS)” and the consecutive “European Train Control System (ETCS)” combine not less than 25 national signalling systems into one – the respective costs for implementation are paramount.

Why do I give this review? Because history is a teacher!

So many steps have been taken to create the rail system to the technology- and safety-standards of today.

So many ideas have been produced and put into realisation to meet the ever valid goals like

- more safety
- higher performances
- higher speeds
- less energy consumption and less air pollution
- reduced noise propagation
- less wear and tear
- less cost
- less manpower
- etc.

Railway today is a modern, reliable transportation system, which is operated almost seamlessly in the whole of Europe, with the potential to being used much more intensively. This is the reason why forward thinking politicians (expressed by legislation of the European administration!) bet on railways as an important future transport mode! And such ideas are urgently needed.

We in fact are in a dramatic change of our living conditions. Population growth is dramatic. The world counted for 2,5 billion inhabitants in 1950, now it is more than 7 billion with the greatest growing rates close to Europe in the Near East and in Africa. This goes with limited and shrinking resources of crude oil for fuel production, with the majority of the remaining reserves in politically unstable areas. Railways are the European option to master the future of transport! Western Europe has initiated NEW railways already 40 years ago. In France the TGV-system was developed, which quickly developed an impact to other countries to follow like

- Germany (ICE)
- Spain (AVE)
- Italy, Great Britain
- Belgium, Netherlands, Sweden
- Switzerland
- Austria presently spends more annual funds for rail than for roads!
- Not to speak about Eastern Asia.
- Korea and Taiwan have successfully constructed High-Speed Rail systems and continue to do so.
- China overlaid its territory with a network composed from long distance High-Speed-lines, supplemented with fast lines and even Heavy Haul freight lines for coal and grain transportation.
- Also India has started construction of brand new railway lines, although exclusively for freight transportation.

Railway technology is in full swing! Is there any innovation needed?

It is my intention to demonstrate the need for continued progress and innovation even in the well-developed rail systems. Considering innovations is the best practice to understand the present solutions – and nobody will seriously maintain that existing technology does not work! Nowadays European railways basically change – with the intention to prepare for higher transport efficiency in the future. Due to EU-legislation the principal arrangement of a present railway undertaking as a uniform structured multi-task enterprise, governed by a board of directors with special responsibilities each, has altered into a conglomerate of separate, independent companies with their own financial balance sheets. There is a strong believe that organisational changes can turn railways to higher efficiency. These new structures give way to a multitude of legal arrangements and create a playfield for lawyers of all qualifications.

To support this conversion the European Railway Engineers were forced into the codification of their knowledge in the form of 'Euronorms (EN)' and 'Technical Specifications for Interoperability (tsi)'. As engineers are somewhat naïve – and on the other hand were accustomed and willing

to organize themselves as they already did beforehand in the frame of UIC-working groups – they followed the political desire and produced the intended norms.

And now find themselves before two situations:

- The lawyers and economists, who make the new class of decision makers, generously thank the engineers for the completion of their work – with the remark: “Now we have the rule-books, so we do not need engineers any more!” AND
- 'These rulebooks establish the proven technology, we do not need developments or new ideas any more!'

The driving forces in every market are better performance, reliability and prices.

Railways compete via their products, material ones and immaterial ones. Design ideas and innovative production methods are developed and offered. The evaluation in a practical application, however, became a growing problem. The standards are as numerous as the institutions involved. The bureaucratic obstacles grew faster and greater than the engineering ideas.

Occasionally doubts are voiced that the innovation does not match the given framework of standards.

There is no discussion whether standardisation is necessary or not. The use of railway equipment throughout Europe requires a high level of standardisation, for vehicles and infrastructure as well. This must not be taken into doubt and should not be challenged.

BUT: Standardisation is NOT a reason to counteract innovation – and particularly not implementation! Standardisation is needed to secure daily operation, progress is needed to secure the future! It is a misunderstanding of managers they can reach their goals of efficiency, of improved business-results, of more reliability etc. by deliberately refusing innovative developments and the respective funds. In most cases it is NOT the innovation as such which is concerned, but the delayed and/or hindered IMPLEMENTATION, which kills the idea.

With respect to intellectual properties industrial companies are better off than private inventors, because patent applications, development and testing need time, sometime years, many years. And the duration of patents is limited to 20 years (only), a short time compared to the eternal life of railways. Also the cost of maintaining patents are considerable, especially if worldwide PCT-filing is considered. Without implementation of a patented idea no pay-back happens, which might bring a private patent holder to an early cancellation of the patent protection, without having earned any refunds for his efforts.

## **Without implementation no progress, without progress no future.**

I am convinced that railways are NOT a finally developed technology. There are a great number of ideas, patents and already proven technologies in existence, which all showed their superiority, but did not reach wide-spread use. Three short examples from my personal experience should illustrate:

In the field of running gears (bogies) self-steering bogies have shown their superiority over traditional designs since many years. These bogies combine excellent curving abilities with high-speed-stability and thus resolve the contradiction of traditional bogies, which only allow to optimise EITHER curving OR high-speed. If some simple rules are materialised then the lifetime of the wheel profiles might be extended by 4 to 8 times and the life of a wheel multiplied respectively. Since almost 4 decades such bogies are operated successfully in the Heavy Haul operations of South Africa, where it solved serious technical problems. Today, also other mineral transportation undertakings take advantage from this design.

With the greatest success those principles were introduced at Vienna Underground bogies in 1984. Beside the reduced wear and tear much reduced – almost extinguished – squeeze noise was experienced as well. Only advantages, but no implementation elsewhere. Why? Is it the well known fact that only bad news are reported to each other, and good news are kept in secrecy? Who knows?

Possibly the engineers producing the specifications for new vehicles have not yet heard about this design. Or is it the need to referencing to many years of “operational experience” which is the reason for this blockade? Or must the specification be written in a way to allow every blacksmith to offer a running gear for railway vehicles?

The question is more than actual: How do the specifiers accrue their knowledge about innovative developments? Do they read publications at all? Do they travel to study the options? Do they believe in reports of colleagues?

And - is there engineering background being left with the decision makers?

Or has Railways already turned into a fully commercial game? Do the short-term considerations reflect the long lifetime of railway investments?

Or take infrastructure: The traditional ballast track is sometimes called “overstressed” when it comes to heavy axle load or to high speed. Quickly reasons are found to argue for ballastless track, which is considerably higher in cost, sensitive in construction and inflexible for local refinement in track geometry. There is, however, a solution to reduce the strain in the ballast caused by running trains, to substantially improve the durability of track geometry and to increase the lateral stability to accept the temperature increases caused by eddy-current braking even in hot summer conditions.

This development was called 'frame-sleeper' and is now in track for more than 12 years – with the effect of a substantial reduction of geometry maintenance needs. It was already shown at an early stage that in spite higher initial cost the LCC is considerably lower thanks to reduced maintenance and much increased geometry durability. Obviously in Austria decision makers do not trust in the future existence of railways otherwise the missing implementation at a wider scale is not explainable.

In the meantime sleepers of this type were installed in 2009 at the 'Transport Technology Centre (TTCI)' in Pueblo, Colorado, USA, on the Heavy Axle Load (HAL) test ring under 35 metric tons axle load. An unmanned test train circles the loop to accumulate accelerated test loads. The results are excellent, at 300 MGT (million gross tone) no need for an intervention is seen and – by general experience with ballast track – I foresee an even much longer excellent behaviour of this type of track. 300 of these sleepers are stored for installation in a running track on Union Pacific Railroad (UPRR), but nothing happens. What else than a successful demonstration can be done to convince railway officials of the advantages of an innovation? Of course, also the business case was done with excellent results, but even this paper did not trigger movement.

One more example?

During a visit to Namibia I was invited to ride a track trolley along a big sand dune. Shortly before arriving we became stuck in a sand heap, which was blown over the track. I was told that this was a common problem and manpower is available to dig out the sand covered rails – which later happened.

After this experience I started thinking about a solution – and suggested a sleeper with an elevated rail seat, which allowed sand to be blown through the gap between the ballast table and the rail foot. 80 m of this design was installed and it works until today, while other efforts and sleeper designs failed.

The installation took place in 1998, only 15 years back and works reliably since. No further implementation was done. But time in Africa is substantially slower than in Europe anyway!

These are only three cases of my very personal experience, many others may be quoted by others.

One major drive for innovation is lowering cost. Self evidently a new solution must be 'cheaper' – in the long run. But what is 'the price'? Is it the cost of the prototype? Then you need not to continue – this 'price' is much too high. Or is it the price of the first 10 pieces? Most likely the advantage cannot be demonstrated. Or is it the 'Life Cycle Cost', including inspection, running maintenance and renewal? Then we agree.

Engineers have been cost-conscious since ever. Nevertheless it became necessary to lay down detailed cost-calculations before the implementation of the subject. 'Life-Cycle-Cost (LCC)' is the

magic word. The figure counts and is entered into the evaluation scheme with a high priority-weight. The engineer's understanding is second instance.

But: What in fact is LCC? Which is the life-time to enter into the calculation? How – in the case of an innovation – is LCC seriously estimated BEFOREHAND without some long-term experience? A lot of fantasy is used to define LCC in commercial offers. It is so easy to forecast something idealistic! If the life of the item is over then the inventor has long passed away! It is understandable that the inventor or developer tends to see LCC at the better, the lower, rate than the buyer, the operator, who intends to put these figures under doubt. So the discussion over 'correct' pricing of new items on the market will continue.

LCC certainly are an indication for the intended advantages, but it is NOT a fixed figure. LCC can of course be exactly distinguished – after the life-time of a subject.

Specifications are another difficult obstacle to a break-through of an innovation. In any specification references are required, places and transport companies named, where the old stuff is operated, which itself was referenced to even older stuff. In this vicious circle immense resistances are built up and it becomes extremely difficult, if not impossible, to help an innovation break through. From my own personal experience this is only the case, if the problems with existing technologies are really severe and really costly and with the potential to seriously influencing operations. If these preconditions exist then there is some chance to introduce innovative ideas! Specifications extraordinarily reflect the past – and definitely do not support innovations. How can a list of 'successful applications' be produced if something completely new is considered? This is simply not possible! The introduction of a real innovation depends from a decision maker with an engineering understanding – or people who at least listen to you. It is definitely much easier to compare two price figures – who cares on secondary cost from maintenance to early replacement? And how is wear and tear evaluated, which is caused on the infrastructure by a piece of rolling stock? This is generally an unsolved issue. Some indications can be concluded, but truth has another quality.

And the risk!! Why should a decision maker take some risk, which he cannot oversee? Innovation from his standpoint is always a risk! Such risk can only be matched by confidence into a company's ability or by an out-of-scale confidence into the inventor. It is understandable that also this confidence is a limited one.

In our legally dominated time we always have to apply for CERTIFICATION: Certifiers must by profession doubt any information they are given. And consequently doubts are voiced and confirmations required, by paper and by experiments. Again we see less and less engineers in these responsible activities, which require growing efforts to convince these 'masters of doubts'. But innovations need implementation under all cases, so engineers are forced to follow this path, a sometimes thorny path.

In the past the experimental phase of an innovation was rather extended and multiple tests were specified for execution and consequently were carried out. This also reflected the joint responsibility of 'the railway organisation' as such for the smooth interaction between rolling stock and infrastructure. Testing – and developing – of locomotives, for example, was a many-year undertaking with performance checks, running tests with heavy and fast trains, in flatlands and in the mountains, with dismantling exercises etc., etc.

Today these tests, wherever possible, have been substituted by computer exercises. Practical tests were reduced and replaced by faith into computer results. This saves cost for test-staff and does not interfere with scheduled train movements. Unavoidable practical adjustments today are concentrated in special test centres, but this is nevertheless an artificial environment and practical use may show unexpected shortcomings.

The true confirmation of a new idea is – and was - always the practical application. Implementation in fact is the ONLY proof of innovation, because:

**INNOVATION WITHOUT IMPLEMENTATION EQUALS ZERO!**





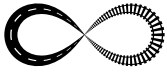

## LIFETIME ENGINEERING FOR ROADS

Laszlo Gaspar

*KTI Nonprofit Ltd., Hungary*

### Abstract

Lifetime engineering is the concretisation of an innovative idea for solving the dilemma existing between an infrastructure as a long-term product and the short-term approach to its design, management and maintenance planning. Although lifetime engineering was originally developed for buildings and bridges, its principles can be readily utilised for roads. Sustainable road construction needs the assessment of Life Cycle Costs (LCC) of the structures, the encouragement of data collection for benchmarks, as well as public procurement and contract award incorporating LCC. The use of lifetime-oriented road management has become worldwide more and more widespread. Highest possible recycling rate in road construction is strived for. Several lifetime engineering elements (life cycle costing, pavement performance models, user cost calculation, internalisation of external road effects, evaluation of the actual effect of road maintenance to pavement performance etc.) are already available in Hungarian road management. Two of them (life cycle analysis and performance models) are also introduced. Life cycle analysis includes agency and road user costs, besides transformation functions for the calculation of performance parameters to performance indices. Road user costs cover vehicle operation costs, time delay costs and user costs during condition improving interventions. 5% discount rate is applied. Pavement performance models are developed on the results of yearly trial section monitoring. The 20-year long data series allows to create models in 14 road section classes for unevenness, rut depth, bearing capacity, macro and micro texture, as well as surface defects. The models have been developed as a function of traffic passed and of pavement age.

*Keywords: Lifetime engineering, road engineering, social aspects, human aspects, road life cycle.*

### 1 Introduction

Our society is living through a period of great change, in which we can also see changes in the central goals and requirements of construction techniques. The challenge to the present generation is to lead rapid development of a global economy towards sustainability in relation to our entire society, economy, social welfare and ecology.

Buildings and civil and industrial infrastructures are the longest lasting and most important products of our society. The economic value contained in buildings, and civil and industrial infrastructures are, to say the least, significant; and the safe, reliable and sound economic and ecological operation of these structures is greatly needed. In industrialised countries buildings and civil infrastructures represent about 80 per cent of national property. Construction plays a major role in the use of natural resources and in the development of the quality of the natural environment in our time. Consequently, building and civil engineering can make a major contribution to the sustainable development of society.

The sustainability of buildings and built environment can, in short, be defined as thinking in time spans of several generations. Sustainability includes social aspects (welfare, health,

safety, comfort), economic aspects, functional aspects (usability for changing needs), technical aspects (serviceability, durability, reliability) and ecological aspects (consumption of natural resources such as energy, raw materials and water; air water and soil pollution, waste production; and impact on biodiversity), all related over the entire life cycle of the built facilities. It could be claimed that a built facility can only be as good as its design. The technical definition for sustainable building can be: “Sustainable building is a technology and practice which meets the multiple requirements of the people and society in an optimal way during the life cycle on the built facility”[1].

## 2 What is lifetime engineering ?

Lifetime engineering is an innovative idea and a concretisation of this idea for solving the dilemma that currently exists between infrastructures as very long-term products and their short-term approach to design, management and maintenance planning [2]. The main elements of lifetime engineering are:

- lifetime investment planning and decision making,
- integrated lifetime design,
- integrated lifetime management and maintenance planning,
- modernisation, reuse, recycling and disposal,
- integrated lifetime environmental impact assessment and minimisation.

The integrated lifetime engineering methodology concerns the development and the use of technical performance parameters to guarantee that the structures meet throughout their whole life cycle the requirements coming from human conditions, economic, cultural, social and ecological considerations. Thus, using lifetime engineering, the human conditions (safety, health and comfort), the monetary (financial) economy and the economy of the nature (ecology) can be controlled and optimised taking into account cultural and social needs.

For life cycle design, the actual analysis and design are expanded also to the levels of monetary economy and ecology. Life cycle expenses are calculated into present value or annual costs by discounting manufacture, construction, maintenance, repair, rehabilitation, reuse, recycling, disposal etc. expenses

However, lifetime engineering was originally developed for buildings and bridges, its basic principles can be readily utilized for roads, as it will be shown subsequently.

## 3 Lifetime engineering development process

There is a clear need for a uniform approach for assessing, validating and operating infrastructures, buildings and industrial, facilities with the consideration of the generic requirements presented in Table 1 [3].

Moving into lifetime technology means that all processes should be renewed. Furthermore, new methodologies and calculation methods are to be adopted from mathematics, physics, system engineering, environmental engineering etc. However, the need for strong systematic transparency and simplicity of design process has to be kept in mind in order to keep the multiple issues under control and to avoid excessive design activities. The adoption of new methods and process necessitates the renewal of the education and the training of all stakeholders.

Since the design for durability is an important element of lifetime engineering, its main principles will be briefly presented.

**Table 1** Generic classified requirements of the structure.

1. Human requirements functionality in use safety health comfort	2. Economic requirements investment economy construction economy lifetime economy in: operation maintenance repair rehabilitation renewal demolition recovery and reuse disposal
3. Cultural requirements building traditions life style business culture aesthetics architectural styles and trends imago	4. Ecological requirements raw materials economy energy economy environmental burdens economy waste economy biodiversity

## 4 Design for durability

Durability design methods can be classified starting from most traditional and ending in most advanced methods as follows:

- a design based on structural detailing
- b reference factor method
- c limit state durability design.

### 4.1 Durability design with structural detailing

Structural detailing for durability is a dominant practical method which is applied to all types of materials and structures. The principle is to specify structural design and details as well as materials so that both deterioration effects on structures, and the effects of environmental impacts on structures, can be eliminated or diminished. The first of these is typically dominant when designing structures, such as wooden buildings, which are sensitive to environmental effects. The second principle is appropriate for structures which can be designed to resist even stronger environmental impacts, such as concrete, coated steel or wooden structures. The methods and details for durability detailing are presented in current norms and standards.

### 4.2 Reference factor method

The reference factor method aims to estimate the service life of a particular component or assembly in specific conditions. It is based on a reference service life – in essence the expected service life in the conditions that generally apply to that type of component or assembly – and a series of modifying factors that relate to the specific conditions of the case. The method uses modifying factors for each of the following:

- A quality of components
- B design level
- C work execution level
- D indoor environment
- E outdoor environment
- F in-use conditions
- G maintenance level.

Estimated service life of the component (ESLC):

$$ESLC = RSLC \times A \times B \times C \times D \times E \times F \times G \quad (1)$$

where RSLC is the reference service life of the component.

The reference factor method is always an additive method, because reference service life always has to be known. The reference factor method is most often needed because the environmental exposure (environmental load onto structure) usually varies over a wide scale. Many parametric methods including the values of parameters in different conditions already exist.

### 4.3 Limit state durability design

Although this method is presented and applied in detail for concrete structures, similar methods can also be applied to steel, wooden and masonry structures. Deterioration processes, dictating environmental loads, degradation factors and degradation calculation models are different for different materials.

The simplest mathematical model for describing a 'failure' event comprises a load variable  $s$  and a response variable  $R$ . In principle the variables  $s$  and  $R$  can be any quantity and be expressed in any units, the only requirement is that they are commensurable. Thus, for example,  $s$  can be a weathering effect and  $R$  can be the capability of the surface to resist the weathering effect without too much visual damage or loss of the concrete reinforcement cover.

If  $R$  and  $s$  are independent of time, the 'failure' can be expressed as follows [4]

$$\{\text{failure}\} = \{R < S\} \quad (2)$$

The failure probability  $P_f$  is now defined as the probability of that 'failure':

$$Pr = P\{R < S\} \quad (3)$$

Either the resistance  $R$  or the load  $s$  or both can be time-dependent quantities. Thus the failure probability is also a time-dependent quantity. Considering  $R(t)$  and  $S(t)$  are instantaneous physical values of the resistance, and the load at the moment  $\tau$  the failure probability in a lifetime  $t$  could be defined as:

$$Pr(t) = P\{R(\tau) < S(\tau)\} \text{ for all } \tau \leq t \quad (4)$$

The determination of the function  $P_f(t)$  according to eqn. (4) is mathematically difficult. That is why  $R$  and  $s$  are considered to be stochastic quantities with time dependent or constant density distributions. By this means the failure probability can usually be defined as:

$$Pr(t) = P\{R(\tau) < S(\tau)\} \quad (5)$$

According to the eqn (5) the failure probability increases continuously with time.

At a given moment of time the probability of failure can be determined as the sum of products of two probabilities: 1) the probability that  $R < S$ , at  $S = s$ , and 2) the probability that  $S = s$ , extended for the whole range of  $S$ :

$$Pr(t) = P_f = \int P\{R < S \mid S = s\}P\{S = s\} \quad (6)$$

Considering continuous distributions the failure probability  $P_f$  at a certain moment of time can be determined using the convolution integral:

$$P_f = \int F_R(s) f_s(s) ds \quad (7)$$

where:

$F_R(s)$  the distribution function of R,  
 $f_s(s)$  the probability density function of s, and  
s the common quantity or measure of R and S.

The integral can be solved by approximate numerical methods.

## 5 Sustainable road construction

Sustainable development is a matter of satisfying the needs of present generations without compromising the ability of future generations to fulfil their own needs [5]. Sustainable development means sustainability not only ecologically (= environmentally) and economically but also socially and culturally.

SBIS (Sustainable Building Information System) has been established in Canada to provide users with non-commercial information about sustainable building around the world, and to point or link the user to more detailed sources of information elsewhere.

The World's Largest Life Cycle Assessment – LCA database is available in Japan quantifying the products' impact on the environment throughout its life cycle.

The series ISO 15686 'Building and constructed assets – Service life planning' offers new tools for the life cycle planning of buildings or other constructed assets included roads.

The final report of EC-project 'Life Cycle Costs in Construction' [6] has the following recommendations:

- adoption of a common European methodology for assessing Life Cycle Costs (LCC) in construction, encouragement of data collection for benchmarks, supporting best practice and maintenance manuals,
- public procurement and contract award incorporating LCC,
- life cycle cost indicators displayed in buildings open to public,
- life cycle costing at the early design stage of a project,
- fiscal measures to encourage the use of LCC,
- development of guidance and fact sheets.

The ways in which built structures are procured and erected, used and operated, maintained, repaired, rehabilitated and finally demolished (and recycled, reused) constitute the complete cycle of sustainable construction activities. The use of materials, energy and water, and mobility should be minimised [5]

## 6 Life cycle of road structures

Several countries including Finland [7] have developed lifetime-oriented road management. Usually firstly significant contributions to the research and development of long-term pavement performance are made. The long-term performance models are naturally never complete (final). Secondly, the procurement methods go through profound changes. Typically, the road maintenance responsibility after investment is included in the contract. The daily maintenance contracts therefore cover larger geographic areas with longer contract periods. The contractors and consultants need to learn how to evaluate the life cycle and the life cycle costs of roads. Empirical knowledge, careful observation of existing structures and competence are the keys to success. The client has to clearly describe the targets and the desired quality

levels. Besides, the client has also to be in charge of collecting preliminary data to ensure that tenders can be submitted without unnecessary risks.

The life cycle of pavement depends on the bearing capacity – and in a lot of countries the frost susceptibility – of pavement structure. Nowadays, these factors are usually satisfactorily taken into account for main roads. At the same time, for secondary roads the relevant threshold values allow greater variation. As a result, more maintenance measures are required during life cycle.

Typically, rutting type defects due to the deformation of unbound base or sub-base layers need to be repaired. However, unevenness is also often the cause of major maintenance. The selection of rehabilitation methods depends on the factors causing the actual defect. Environmental aspects are also more and more considered by the recycling of road structural material.

Construction expenses are generally rather high compared to life cycle maintenance costs. The former expenditure can be reduced by the possibly maximum rate of recycling, the minimisation of using materials from outside.

There is no generally accepted methodology to calculate the residual value for road structures at the end of investigation period. One of the possible ways is to consider the construction costs during the planning period as increasing (positive) factor and the deterioration (wear) of structures as decreasing (negative) factor. The remixing of wearing course slightly changes the actual residual value. The residual value of a road structure can be higher than the asset value at the beginning of the period.

The increasing use of performance-based specifications in road project tendering and contracting also paves the way for the application of the principles of lifetime engineering [8].

## **7 Some lifetime engineering elements available in Hungarian road management**

Although it is evident that the lifetime engineering as a science has not been utilised, usually not even known by the Hungarian road engineers, several of its elements have already been worked out and applied in road (pavement, bridge etc.) management systems and in practice [9] as follows.

- a Whole life (life cycle) costing is more and more used in the planning and design of major Hungarian road projects.
- b Pavement performance models have been developed for the forecasting of future behaviour of various road pavement types as a function of time or traffic passed [10; 11]. The user costs (vehicle operating costs, time delay costs and accident costs) as a function of different pavement conditions levels were also estimated and utilised in the national economy level forecast of life cycle costs.
- c Considerable effort has been made for the internalisation of such external road effects as air pollution, traffic noise and vibration.
- d The actually effect of major road maintenance (rehabilitation) has also been evaluated using trial section monitoring information [12].

### **7.1 Life Cycle Cost Analysis**

Road Technical Guidelines [13] has been made for the analysis of the life cycle costs of Hungarian pavement structures. Some of the relevant specifications in the Guidelines are as follows:

- design life for motorways and expressways with flexible and semi-rigid pavement structures is 20 years; for national main roads 15 years; secondary roads 10 years; motorways and main roads with rigid or composite pavement structures 40 years,

- agency (construction, operation maintenance) and road user costs for a unit road length are taken into account in the life cycle analysis,
- the construction costs considered include the expenditures of the realisation of various pavement structural alternatives based on actual organisational data and the use of resources available,
- the operational costs considered are confined to the pavement cleaning and winter maintenance taking into account the operational strategy selected,
- the pavement condition is characterised by the following condition parameters: bearing capacity, unevenness, surface defects, rut depth and skid resistance with macro and micro roughness as components,
- transformation functions are defined for the calculation of performance parameters (e.g. IRI value in m/km for pavement unevenness) to performance indices (e.g. unevenness 5-scale note),
- the following equation is used for the complex evaluation of pavement condition:

$$A = 0.4B + 0.1C + 0.2D + 0.1E + 0.1F \quad (8)$$

where

- A complex pavement condition index,
- B bearing capacity index,
- C unevenness index,
- D rut depth index,
- E surface defects index,
- F skid resistance index.

- the pavement deterioration process for flexible, super flexible and semi-rigid structures is described by the eqn (9):

$$Y(t) = A + B * e^{-ct} \quad (9)$$

where

- Y pavement condition parameter considered,
- T age in years,
- A,B,C constants as a function of pavement type and traffic (Table 2),
- the condition parameters considered for jointed cement concrete pavement are presented in Table 3,
- maintenance calendars of various pavement structure types were agreed for pessimistic, realistic and optimistic scenarios (see Table 4 as an example),
- road user costs considered include vehicle operation costs (with constant and variable elements), time delay costs, accident costs, user costs during condition improving interventions,
- economic evaluation is carried out by the following methodologies: benefit-cost ratio, internal rate of return, net present value,
- discount rate applied is 5%.



**Table 2** Constants for pavement deterioration equations.

Pave-ment type Traffic size	Flexible			Super flexible			Semi-rigid		
	Low	Medium	High	Low	Medium	High	Low	Medium	High
Surface defects									
A	1.68	1.51	0.99	1.67	0.79	-	1.74	2.38	-
B	0.85	1.02	0.84	0.84	1.32	-	0.87	0.49	-
C	-0.01	-0.02	-0.10	-0.10	-0.15	-	0.06	-0.06	-
Bearing capacity									
A	1.01	0.46	0.90	0.80	1.60	-	1.52	0.45	-
B	0.73	0.40	-0.63	1.12	-1.26	-	0.75	0.75	-
C	0.12	0.02	0.04	0.03	0.02	-	-0.01	0.57	-
Unevenness									
A	2.67	1.82	1.68	3.92	4.52	-	2.92	-	-
B	0.91	0.	0.64	0.88	0.01	-	0.77	-	-
C	16.35	-0.01	1.91	0.11	-0.35	-	0.10	-	-
Rut depth									
A	2.45	-	-	6.69	2.60	-	4.14	-	-
B	1.42	-	-	-2.2	2.15	-	-0.10	-	-
C	-0.13	-	-	0.09	-0.11	-	55.23	-	-

Note: low traffic size < 3000 vehicle unit/day,  
medium traffic size 3000-8000 vehicle unit/day,  
high traffic size > 8000 vehicle unit/day.

## 7.2 Pavement performance models

The life-time engineering takes for granted the reliable forecast of the future performance of the facilities concerned (e.g. road pavements). For this purpose scientifically based pavement performance models can be used. In Hungary, the yearly monitoring of 60 trial sections of 500 m length chosen of the national highway network started in 1991 [14]. The 20-year long data time series of the following condition parameters serve as the basis of the pavement performance models of 14 road section classes:

- unevenness (laser RST),
- rut depth (laser RST),
- bearing capacity (KUAB FWD),
- macro texture (laser RST),
- micro texture (laser RST),
- surface defects (visually aided by a keyboard-type device).

Any of the 14 road section classes is typical for a considerable share of the 30 000 km-long Hungarian national highway network for its pavement structure, traffic size and sub-grade strength.

The pavement performance models for each condition parameter have been developed as a function of traffic passed (vehicle units) and pavement age (years).

Table 5 presents an example for the pavement performance models in Hungary.

**Table 3** Condition parameters with the lower and upper deterioration thresholds for jointed cement concrete pavements.

Pavement type	Jointed cement concrete pavement (slab length <6m)		
	Lower and upper thresholds		
Deterioration	Lower and upper thresholds		
Traffic size	Low	Medium	High
Structural interventions			
Structural cracking (slab %)	4.0/50.0	3.0/40.0	2.0/30.0
Damaged joints (slab %)	4.0/30.0	3.0/20.0	2.0/10.0
Corner breaks (slab %)	3.0/30.0	2.0/20.0	1.0/10.0
Curling, average (mm)	4.0/128.0	4.0/15.0	4.0/12.0
D-cracking (severity)	Medium – high		
Damaged crack filling (crack %)	>25/-		
Load transfer (%)	<50/-		
Functional interventions			
Skid resistance	Locally lowest acceptable value/-		
Unevenness, IRI (m/km)	1.4/3.5	1.2/3.0	1.0/25

Note: low traffic size < 3000 vehicle unit/day,  
 medium traffic size 3000-10 000 vehicle unit/day,  
 high traffic size >10 000 vehicle unit/day.

## 8 Concluding remarks

Lifetime engineering is an emerging science originally developed for buildings, bridges, and industrial infrastructures. Since its principles proved to be useful for the project types mentioned, an attempt was made to use (adapt) them to highways, actually road assess management [15]. Some of the results obtained in Hungary in this field are presented in the paper.

**Table 4** A part of a maintenance calendar for jointed cement concrete pavements (example).

Years	Pessimistic	Realistic	Optimistic
1	Routine maintenance	Routine maintenance	Routine maintenance
2	Routine maintenance Slab replacement on 0.2 % of the surface	Routine maintenance	Routine maintenance
3	Routine maintenance	Routine maintenance	Routine maintenance
4	Routine maintenance	Routine maintenance Slab replacement on 0.2 % of the surface	Routine maintenance
5	Routine maintenance	Routine maintenance	Routine maintenance Slab replacement on 0.2 % of the surface
6	Routine maintenance	Routine maintenance	Routine maintenance
7	Routine maintenance	Routine maintenance	Routine maintenance
8	Transversal clamping of cracking above 30 m length, refilling of 10 % of joints Routine maintenance	Routine maintenance	Routine maintenance

**Table 5** Example for pavement performance model

Road section class V Flexible pavement structure, AADT=1501-3000 unit veh. /day; sub-grade CBR=max 7%		
Condition parameter	Performance model as a function of	
	pavement age	traffic passed
Surface defects (note)	1.47+0.09 AGE	1.44+0.11 TRAF
Unevenness, IRI (m/km)	1.74 exp (0.12 AGE)	1.79 exp (0.13 TRAF)
Rut depth (mm)	2.09 exp (0.10 AGE)	2.15 exp (0.09 TRAF)
Micro texture	0.29-0.009 AGE	0.34-0.011 TRAF
Macro texture	0.54-0.014 AGE	0.61-0.014 TRAF

Note AGE – pavement age in years,

TRAF – number of vehicles passed expressed in vehicle units during pavement age.

## References

- [1] Sarja, A: A vision of sustainable materials and structural engineering. In: Tuuti, K. (ed.) Selected studies from Scandinavia. Report TVBM-30-78. Lund University, Lund Institute of Technology, pp. 141-193, 2002.
- [2] Work description of LIFETIME proposal no. CTC1-2001-43046 to Competitive and Sustainable Growth (GROWTH) Programme, Espoo, Finland, (Co-ordinator: Asko Sarja), 41 p, 2001.
- [3] Sarja, A.: A process towards lifetime engineering in the 5th and 6th Framework Program of EU. 2nd International Symposium ILCDES, Kuopio, Finland. pp. 7-12, 2003.
- [4] Sarja, A & Vesikari, E.: Durability Design of Concrete Structures. RILEM Report Series 14. E&FN Spon: London, 143 p, 1996.
- [5] Tupamäki, O.: Total LCC and Sustainable Construction. 2nd International Symposium ILCDES, Kuopio, Finland, pp. 103-109, 2003.
- [6] Roger-France, J.-F. et. al.: Life Cycle Costs in Construction. EC DG Enterprise, 68 p, 2003.
- [7] Kalliokoski, A. & Kasari, T.: Life Cycle of Road Structures in Road Construction in Practice. 2nd International Symposium ILCDES, Kuopio, Finland. pp. 349-354, 2003.
- [8] Mäkinen, S.: Pilot Project of Lifetime Design of Asphalt Concrete in Finnish Road Administration. 2nd International Symposium ILCDES, Kuopio, Finland. pp. 403-408, 2003.
- [9] Gáspár L.: Útgazdálkodás (Road management). Academy Press. Budapest, 361 p, (in Hungarian), 2003.
- [10] Gáspár, L.: Pavement condition before and after rehabilitation. The International Journal of Pavement Engineering & Asphalt Technology, Volume 5, Issue 1, pp. 15-28, 2004.
- [11] Ferreira, A., Antunes, A. & Picado-Santos, L.: Probabilistic Segment-linked Pavement Management Optimization Model. Journal of Transportation Engineering. Nov-Dec. pp. 268-277, 2003.
- [12] Bakó, A.: Optimization Model for Highway Pavement Maintenance. ISAPT II, Kuala Lumpur, Malaysia. CD-ROM Proceedings. 7 p, 2004.
- [13] Útpályaszerkezetek élelciklus elemzése (Life Cycle Cost Analysis of Pavement Structures). Draft Road Technical Guidelines 16 p, (in Hungarian), 2007.
- [14] Gáspár, L.: Highway Pavement Performance Models. 9th International Conference on Asphalt Pavements. Copenhagen, CD-ROM Proceedings. 6 p, 2002.
- [15] Gáspár L.: Lifetime engineering in road asset management. 3rd European Pavement and Asset Management Conference, Coimbra, Portugal, Session B3, CD-ROM Proceedings, 10 p, 2008.

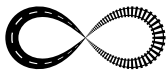

## ENERGY AND ENVIRONMENTAL ASPECTS OF HIGH–SPEED RAIL

Roderick A. Smith, Robert Watson, Jing Zhou  
*Future Rail Research Centre, Imperial College London, UK*

### Abstract

This paper discusses the energy requirements of high-speed rail systems based on the key performance index (KPI) of energy used per passenger km. Comparisons with automobiles and air are favourable to high-speed rail, but with some limitations. High speed trains require high passenger loading (load factor) and, in terms of CO<sub>2</sub> emitted, the proportion of electricity supplied from non carbon sources is important. Aerodynamic design in order to reduce drag is vital, as is light weighting in order to give a nimble footfall and hence to reduce infrastructure maintenance costs.

*Keywords: high-speed train, infrastructure, route design,  
energy consumption, passenger load factor*

### 1 Introduction

A huge number of factors need to be considered during the initial stages of the design of a high-speed train system. The environmental effects include, inter alia, noise, vibration, land use & habitat disturbance. This paper concentrates specifically on energy use, and therefore by implication, carbon dioxide generation. Mission, usually defined by capacity of passengers and hence number of trains, both at the opening date and at dates into the future are fundamental. When coupled with desired journey time, it is obvious that speed plays a key role in the definition of mission. Speed determines energy use, the topic of this paper.

#### 1.1 Some initial principles

When we design a high speed train system, it is natural to think the faster the better. Indeed, national pride may well be served by having the fastest train. But other considerations intervene. Over a fixed distance,  $s$ , traversed at constant speed,  $v$ , the time taken,  $t$ , is inversely proportional to the speed. Furthermore on differentiation, the extra time saved,  $\Delta t$ , by going a little faster by a given amount,  $\Delta v$ , is inversely proportional to the square of the speed. Thus, as far as journey time is concerned, we enter the law of diminishing return by going even faster. The 60 min of a 250 k journey taking an hour at 250 kph, is reduced by 2.3 min if the speed increases to 260 kph: whilst at 300 kph, the 50 min journey is reduced by only 1.6 min at 310 kph.

But, of course, constant speed journeys are difficult to achieve. Notwithstanding an initial acceleration phase and a final braking stage, there are many reasons why speed is not constant, inter alia, curvature of route, passage through tunnels, gradients and naturally, intermediate stops to serve passengers. Thus overall journey time is dependent on the average speed, rather than the maximum, but it is desired when a line is designed that the average speed achieved is as near to the maximum as is reasonably possible. This requires

very shallow curvature both horizontally and vertically in order to limit discomfort for the passengers. At 400kph, curves as generous as 7.2 km radius are required.

Going faster has the merit of increasing the capacity of the line (assuming all traffic moves with the same speed) and increasing the utilization of the vehicles. But there are two important reasons for limiting the maximum speed. First, as we go faster, the local geometry of the line needs to be preserved with greater accuracy, and the rail's running surface needs to be as smooth as possible to minimize dynamic forces between the rail and the unsprung mass of the vehicle. By reducing the overall vehicle mass, the axle load and the unsprung mass, we can somewhat limit the dynamic load magnification, but we need to maintain an adequate margin of safety for the running gear; wheels, axles, bogies and the like, as light weighting these critical parts increase the propensity for fatigue damage. The cost of maintenance of the track is strongly dependent on the speed and rises continuously and very steeply at speeds in excess of 250 km/h. Second, the energy needed to drive the train increases roughly with the square of the speed. As energy costs increase, this can become a significant component of operational costs and additionally increases the carbon dioxide produced if the electricity source includes fossil fuels. If the average distance between stops is longer, a higher speed is justified compared with a compact system with shorter city spacing.

It is clear therefore, that 'as fast as possible' must be tempered with realism in a complex juggling of overall journey time against increasing maintenance and energy costs. No general formula can be given which in all cases will identify the 'best' speed': each particular system must be considered with its own merits and constraints. Indeed, in common with other transport modes, if saving energy is the goal, then not moving is the solution.

## 2 On what does the energy consumption of a high speed train depend?

For the purposes of this discussion, it is convenient to discuss the energy dependence on three factors, the train, the route and the load factor, all of which combine to define the mission of a particular train on a particular system.

### 2.1 The train

Probably the most obvious, exciting and appealing aspect of a high-speed train is its front end shape, determined from aerodynamic drag reducing considerations. The rounded nose 'bullet' of the original Shinkansen Series 0 of 1964 now looks distinctly dated in comparison to the long and highly refined nose shapes of say the 500 series or the later 'platypus' beak of the 700 series (See Figure 1). So, the frontal area, length of train, smoothness of the underside, extension of skirts enclosing the running gear down to line level and the smoothness of inter-coach connections all contribute to reducing drag. The theoretical maximum speed is attained when the traction force just balances the resistance, predominantly aerodynamic drag. Higher speeds need either more installed power or less drag, or both.

The current collector(s) (pantograph), not only adds to drag, but is a significant source of noise at high speeds. Remarkable progress has been made in all these areas over the last several decades, helped by increased computational power allied to computational fluid dynamics (CFD) packages checked against reality by high capacity and high working area wind tunnels. The weight, more properly the mass, of the train has been mentioned previously. Simple Newtonian dynamics indicates the need for greater power to accelerate and brake increased mass. Most high-speed trains now have regeneration capabilities to capture kinetic energy on braking, but careful design is needed to feed this back into the power supply system. So for high-speed trains with limited stops, this Newtonian effect is not as important as in regularly stopping commuter trains, but, as previously noted, the mass effect on dynamic load is critical. In addition to the reduction in unsprung mass, the more even distribution of

axle loads, arising from distributed traction, is beneficial when compared to the large loads a heavy power car exerts on few axles.

Type	CR ratio	AR
4	100	4.4/1.77
100	84	6.5/1.77
300	68	8.0/1.08
700	26	9.2/1.66

Figure 1 Reduction of drag of the Shinkansen, principally by nose shape development. AR is the aspect ratio of nose length to the car body cross-sectional hydraulic radius

Redundancy and improved adhesion are further benefits, balanced against the loss of some longitudinal stiffness from the shared bogies of articulated designs, which have proved their value in several derailments. Clearly then, light weighting is beneficial, and figures as low as 480 kg / seat have been achieved, down from nearly 700 kg / seat in the original Shinkansen, compared with figures approaching 1000 kg / seat for existing “ordinary” trains. Although attention must be pointed to all features of the vehicle, from for example seats to floor panels, wiring, toilets and paint, the greatest attention must be given to reducing the unsprung mass, with the difficult design compromise based on adequate and robust structural integrity, since the critical components of the bogie, wheels, axles etc.. are single load paths and lack redundancy. The golden rule, for a high speed train, is to have the lightest possible footfall on its infrastructure. It is axiomatic that true high speed trains will be powered by electricity. A key part of the equipment of the train is that used to convert the electrical energy, supplied at the current collector, to mechanical energy used at the wheel / rail interface. The achievements of 22 years of development effort in decreasing the mass of tractions motors are well illustrated in Figure 2.



Figure 2 Light weighting of the Shinkansen drive motors: Series 100 introduced in 1985, the N700 in 2007 (JR Central)

It is obvious that the efficiency of the conversions of voltage, rectification and the electric motors needs to be as high as possible and in this respect, advances in electrical engineering have reduced the mass and volume of the components concerned, as well as increased the energy density which they can handle. When we compare the energy used by a high speed train, this efficiency of conversion is important, although losses are generally considerably smaller than the thermodynamic losses of fossil fuel electricity generation followed by high voltage transmission losses. The capture of energy on braking and its regeneration into the supply is now possible and serves to further reduce overall energy consumption. Figure 3 illustrates the losses associated with the conversion of primary energy in the fuel at a typical power station into mechanical energy at the wheel for an electric train. Also, a comparison is made with a diesel train, where the primary energy is onboard the train.

## 2.2 The route

Initially some basic choices have to be made such as ballasted or slab track, the latter promising reduced maintenance costs, with some possible decrease of ride comfort, but most probably higher renewal cost at the end of life.

Then, however the geographical details of the route over which a high-speed train operates have significant effects on its energy requirement. Gradient is obvious, as are curves. In general, high speeds need more generously radiused curves, principally for comfort - to reduce the discomfort of lateral acceleration on passengers. At high speed it is not possible to fully compensate lateral forces by cant alone. A small active tilt of  $1^\circ$  has been incorporated in the 700 series Shinkansen, enabling it to maintain a constant speed over sections of its route where the speed would otherwise be limited by curvature. Tunnels too increase drag, unless the diameter of the tunnel is considerably larger than the cross-sectional area of the train, see Figure 4; a requirement which is generally prohibitively expensive.

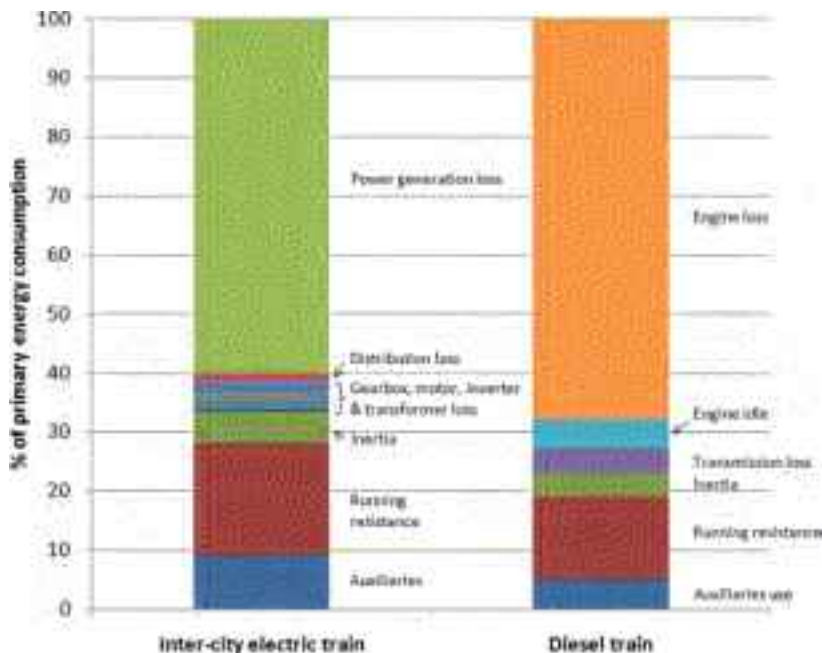
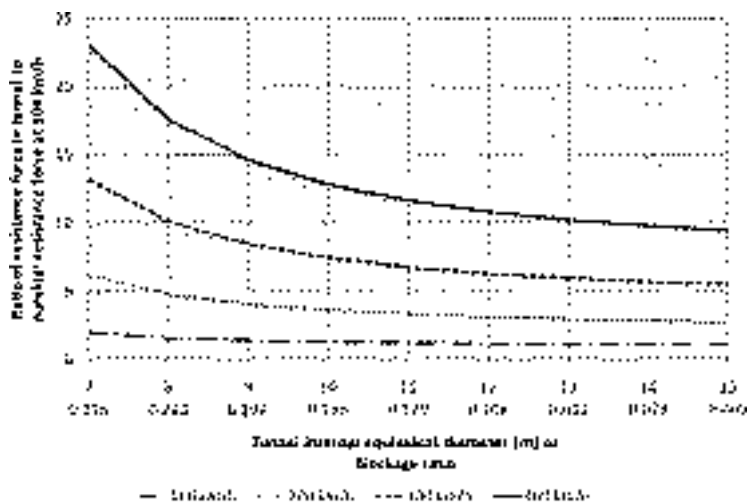

Figure 3 Primary energy consumption of typical inter-city electric (Class 390 Alstom Pendolino) and diesel (Class 221 Super-Voyager) trains [1]

Rapid and high pressure changes on entry and exit from a tunnel can lead to fatigue cracking of the vehicle shell and therefore loss of air tightness. The journey time will obviously be extended by the number of intermediate stops as will the energy consumption, although this energy, when measured per passenger-km, may be reduced by the increased number of passengers which can access the train at the extra stops. The route design therefore needs to minimize tunnels, on both expense and energy terms, and use generous radii of curvature, both horizontally and vertically, but needs to thread its way through the geography of the countryside and the existing structures of the urban area. These aspects lead to considerations of the sinuosity of the route, which when allied with passenger loadings enables us to make comparisons with other modes of transport.



**Figure 4** Effect of speed and blockage ratio on the drag force acting on a train in a tunnel. Blockage ratio is the ratio of the cross-sectional areas of the train and tunnel. (For comparison a typical London Underground tunnel has a blockage ratio of 0.7 to 0.75, a traditional double tunnel from the age of steam, 0.2 and the Channel Tunnel 0.25)

### 2.3 Passenger load factor and the Key Performance Indicator (KPI)

Although many possible candidates have been considered for the metric for comparison of energy by different modes of transport, we will concentrate on energy per passenger unit distance travelled, which is kWh/passenger-km. Each of these terms needs explanation: often seat-km is used instead of passenger-km. The number of seats is a significant factor in the potential usefulness of a mode of transport, but if the seat is unoccupied, then its usefulness is zero (as far as trains go, a useful performance parameter is seats / unit length, which for high-speed trains should be as high as possible: any area not occupied by seats should be rigorously questioned). Obviously, the proportion of occupied seats is crucial in determining energy performance. An effective high-speed system must achieve high load factors, greater than say 80%, over a significant proportion of its operating time and distance, if the expense of operating the train and maintaining the infrastructure are to be covered. An important question to ask is: what do we mean by a kilometre in this context? This can only be the kilometres travelled in the straight line between the journey end points. This is the only distance of utility for the passenger. Thus the concept of route sinuosity defined as actual distance travelled divided by direct distance is important.

Now by design, most high-speed train routes will have sinuosities not much exceeding 1, but we can quote some exceptions, for example Berlin to Nuremberg is 1.33 and London to Paris is



1.44. Even the father of high-speed railways, the Tokyo to Osaka route, is 1.37 times the direct distance and when the Yatsushiro to Hakata section of the Kyushu Shinkansen is completed in the near future, the sinuosity of the Tokyo to Kagoshima route will be in the order of 1.5. The sense of using great circle distances from A to B is then well illustrated and becomes even more important when comparisons are made with air routes.

Finally, where is the kWh in our KPI measured? In many discussions of this topic, the reference point is not clear. Thus, if the energy delivered to the train is used, the major inefficiency of thermal electrical generation is missed. So, wherever possible, the kWh should refer back to primary energy. In summary, our kWh/pass-km means the primary energy used to transport a passenger occupying a seat for 1 km along the shortest distance between the start and end points of his journey.

### 3 The energy selling point of high speed trains

It is frequently claimed that high-speed trains are ‘greener’ than their rivals, meaning they use less energy or produce less CO<sub>2</sub>. Sometimes claims of sustainability are made, but it is prudent to be cautious of such bold, blanket claims, as there are many caveats. If we pose the question, what are the rival modes to high speed trains, it is clear that the sequence road, rail, air follows increasing journey times and distances: where exactly the boundaries are, is blurred and depends on the definition of a dominant percentage. Does a mode dominate when it exceeds 50 % or 75 % of the market? Data for different countries show similar but quantitatively different trends: indeed different routes in the same country often show quantitative differences, encompassing the ‘mission’ specific nature of high-speed trains, see Figure 5.



Figure 5 Rail / air modal split with time and distance (UIC)

Broadly speaking, and for the purposes of comparison in this paper, we assume that for passenger transport, cars will dominate on journeys up to 250 km, high-speed trains will capture the 300 to 1000 km market and planes will dominate at greater distances.

#### 3.1 Comparison with the automobile

By now making a comparison of the energy consumption of a car and a high speed train, we illustrate some of the principles introduced earlier. We choose a very short journey where the car is a real competitor with the train: the UK’s proposed London to Birmingham High Speed 2 route. The sinuosity of the rail route is just 1.06 (173.4 km by train compared with the “as the crow flies” distance of 164 km), whereas the sinuosity of the shortest road route (of distance 191.5 km) is 1.17. The results shown are based on extensive computer modeling of many kinds of mission on the route. The assumptions made in the modeling for the train, route

and driving strategy are detailed in the traction energy calculations, which formed part of the UK government's original proposal for High Speed 2, published in 2010 [2]. The calculations included the effects of different maximum speeds, gradient, line speed and station stops. In the case illustrated below, two intermediate stops are included.

Figure 6 below shows how the energy consumption and journey time by high speed rail vary with maximum speed and passenger load factor. A comparison with the car is based on an assumed 2 1/2 hours travel time from London to Birmingham (city-centre to city-centre) and a fuel consumption of one litre of petrol for every 14 kilometres of travel, a figure close to the average for cars in the UK. As mentioned previously, it is important to make clear exactly where the energy is measured. For this reason, for each passenger load factor of the train, 70 % and 100 %, two curves are plotted; one for the energy drawn from the overhead line at the current collector and one for the fuel energy consumed at the power station. It is assumed that 30% of the energy contained in the fuel at the power station reaches the pantograph of the train, approximately in line with typical thermal efficiencies and transmission losses. The influence of passenger loading is well illustrated in Figure 6, with the figure for the energy consumption measured in kWh/passenger-km obviously highly dependent on the load factor. The important point the results show is made when comparing the energy consumption of the high-speed train at full load with that of a typical car at full load (with 5 people in it). It can be seen that for the same amount of fuel energy consumed per passenger-km, the train takes just over 50 minutes to travel from London to Birmingham, whilst the car takes roughly 2 1/2 hours. Thus, for the same fuel energy per passenger-km, the high-speed train takes over 1 1/2 hours less to get to Birmingham than the car does. This is our concept of 'equal energy time saving'. The superiority of the high speed train in terms of energy and journey time is further confirmed by the fact that average load factors for cars are typically around 30 %, whereas for High Speed 2, load factors in the region of 70% are predicted.

As a comparison we note that JR East [3] consumes 1.14 billion kWh to move 18.15 b pass. km. This is equivalent to 0.063 kWh/pass.km (presumed measured at the pantograph), very similar to the consumption of our model at 70% occupancy and at maximum speeds of c. 300 km/h.

Turning from the energy analysis to carbon dioxide emission considerations, the case for high speed rail is again enhanced by the fact that its electrical power can be generated from a variety of fuels and has the potential to be de-carbonised, unlike current petrol/diesel-powered cars. For example, in France the extensive use of nuclear power to generate electricity gives an emission of approximately 99 grams of CO<sub>2</sub> per kWh at the point of consumption, which compares favourably with the UK's average of about 620 gCO<sub>2</sub>/kWh [4]. By using the average carbon emissions for a UK car of 204 gCO<sub>2</sub>/km travelled [5], on a 191.5 km journey from London to Birmingham, the car would emit approximately 39 kgCO<sub>2</sub>, which is equivalent to about 7.8 kgCO<sub>2</sub> per passenger (with 5 people in the car).

With reference to Figure 6, the high-speed train draws roughly 0.05 kWh/passenger-km from the line, at 100% load when travelling along the HS2 route at its top speed. By using the UK's figure of 620 gCO<sub>2</sub>/kWh, it can be estimated that at top speed the high-speed train emits about 5.4 kgCO<sub>2</sub>/passenger, at 100 % load for the London to Birmingham journey (compared to 7.8 kgCO<sub>2</sub>/passenger for the fully loaded 5-passenger car). This figure dramatically reduces to 0.9 kgCO<sub>2</sub>/passenger when considering the French case for power generation. The time saving of using high-speed rail in this case is likewise over 1 1/2 hours, greater than 60% of the time taken to travel the same journey by car.

The importance of route and curvature has been examined by computing the speed displacement and energy relationships using our train energy calculator, for the proposed high speed train running along the alignment of the current motorways connecting London and Birmingham (M1 & M6), see Figure 7.

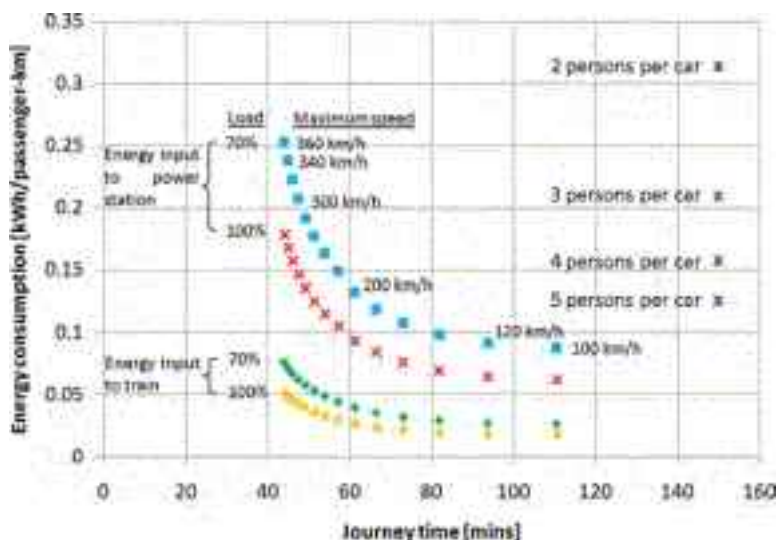

Figure 6 Variation of energy consumption and journey time with maximum train speed for different passenger load factors on the high-speed London to Birmingham route. A comparison is made with the car carrying different passenger numbers and running 14 km for each litre of fuel consumed

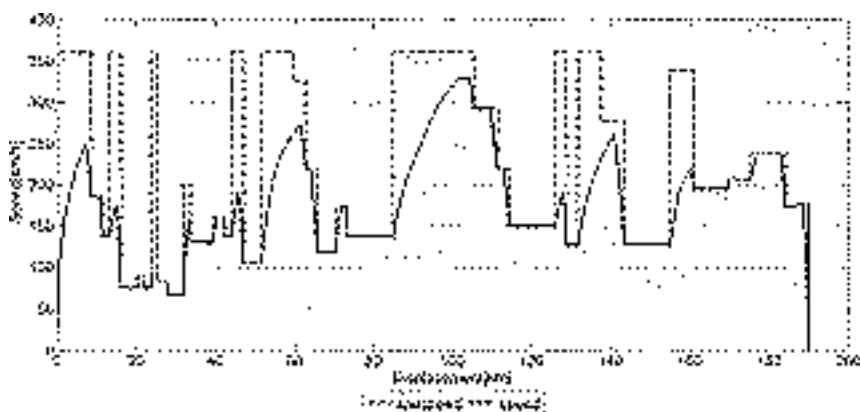

Figure 7 Proposed high speed train running on existing motorway alignment

The severe restrictions of speed are obvious from the figure and the short distances between speed changes mean that the high speed train is never able to reach its maximum speed: the greatest speed achieved of 325kph is over a negligible distance: the maximum speed of 360 kph is never attained. The journey time is no better than the existing conventional train on existing track, while the high speed train running on its proposed non- motorway route, produces a 40% reduction in journey time for the same energy expended. This calculation is a good illustration of the energy advantages gained by using appropriate vehicles on purpose designed track.

### 3.2 Results from aircraft fuel used database

Over the past 5 years, one of the authors (RAS), has collected a database of fuel consumption of a passenger aircraft. A total of 104 flights have been analyzed. The basic information collected on each flight was aircraft type, number of seats, direct distance between the journey end points (together with, in some cases, the actual distance flown), the number of passengers and the actual fuel consumed from engines start to stop. From these were derived, inter alia, the load factor, the fuel used per passenger kilometre and the amount of CO<sub>2</sub> produced by each flight and per passenger-km. Detailed discussion of this rich source of information awaits a further publication, but the key features are introduced here.

The 104 flights recorded covered a total great circle distance of 373,830 km, some 9.33 times round the circumference of the Earth. The flights produced a total of 85.01 million passenger km whilst using 3.753 million kg of fuel. Thus the average fuel consumption was 0.044 kg/pass-km. Using a conversion factor of 49.6 MJ per kg fuel, the average figure for energy consumed is 0.605 kWh/pass-km. Note that this is equivalent to 150 g CO<sub>2</sub>/pass-km, based on 3.4kg CO<sub>2</sub> / kg fuel burned. These figures are based on energy delivered to the tanks of the plane and are not inflated in the case of CO<sub>2</sub> for the additional damaging effect of high altitude emissions: this may be a factor in the order of 2 to 4 although 2.7 is frequently used.

A wide range of circumstances was covered by these flights. The equipment ranged from small turboprops carrying 74 passengers, to four engined 747s fitted with 569 seats for short haul routes. The age of the aircraft ranged from brand new to rather ancient, the majority of the routes were short haul out of London to Western European destinations, and were thus susceptible to air traffic control delays. A few medium haul flights were included, but long haul out of the UK to Japan and South Africa were well represented. And, of course, load factors varied. However, if we examine the data shown in Figure 8, we can see how strongly this factor alone dominates the results. Figure 9 shows the energy consumed for 66 flights with a distance less than 1600 km. The average is 0.7 kWh/pass-km and we note that this is 2.8 times higher than the primary energy used by the high speed train travelling at 360 kph on the mission shown in Figure 6.

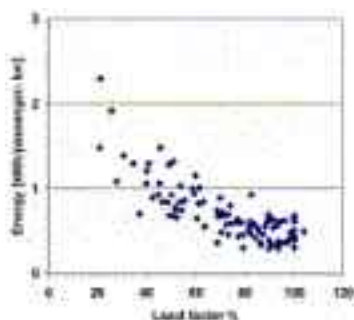

Figure 8 Aircraft: energy used with passenger load factor

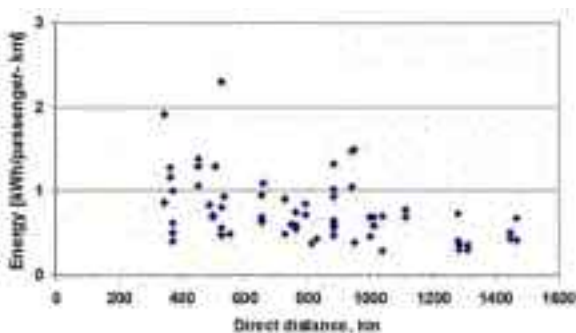

Figure 9 Energy use: short haul flights

## 4 Whole life cycle energy costs

In order to achieve a round picture of the environmental effects of railways it is necessary to estimate the energy (and, hence, carbon) content of the vehicle and infrastructure, in manufacture, use and disposal, together with energy used for maintenance, stations and offices etc. over the whole life of the components. This is a complicated procedure and various efforts have been made to systematise the procedures used, although, as yet, there is no agreed standard

method. One expects that fuel use in service is the most significant part of the energy use for most forms of transport. One of the greatest difficulties is apportioning life to infrastructure and calculating energy used per passenger kilometre produced. Notwithstanding all these details, it would be surprising to find that the 'other' energy costs of high speed rail are more than 10% of the dominant fuel used in transport use.

## 5 Concluding remarks

Our discussion has shown that the use of a single figure to represent energy consumption of a mode of transport is potentially misleading. We have introduced the concepts of 'sinuosity' and 'equal energy time saving' to better calculate and compare energy use on specific missions. We have shown the dominance of passenger load factor in determining energy used per passenger-km delivered. Some broad trends emerge. For short journeys, the energy used per passenger-km by a typical high speed train travelling at maximum speed in the order of 300km/h is about the same as that of a car carrying 3 passengers. Since average load factors of cars are about 1.4, there is a strong energy saving case for a mode shift from cars to high speed trains. The same conclusion is true for short haul aircraft. High speed trains beat planes by a factor of 2.5 to 3, in terms of primary energy consumed at the power station compared with primary energy drawn from the tank of the plane. The comparison with CO<sub>2</sub> produced is affected by the energy mix used to generate electricity. High speed trains have the potential to use de-carbonised electricity. Cars may also share this benefit in the future, but it is unlikely that fuels other than hydrocarbons will be used in aircraft in the foreseeable future. Furthermore, the effect of CO<sub>2</sub> emitted at aircraft cruise altitude is more damaging by a considerable factor than that produced at ground level.

The design of both vehicles and track as a unified system is dictated by the maximum speed of operation. It is always good engineering practice to operate systems in a comfort zone somewhat less than their design capability.

Whilst the merits of high-speed rail must be assessed individually for each route, one can be confident that with such large advantages in the areas of time saving and energy consumption together with potential carbon reduction, high-speed rail should be the transport mode of choice for journeys up to about 3 to 4 hours duration.

## References

- [1] Peckham c. Improving the efficiency of traction energy use. Rail Safety and Standards Board (RSSB). Report number T618, 2007.
- [2] HS2 Traction Energy Modelling, available at <http://www.hs2.org.uk/supporting-documents-temp>
- [3] JR East Sustainability Report 2009, Annual Report 2010.
- [4] AEA. 2010 Guidelines to Defra / DECC's GHG Conversion Factors for Company Reporting Version 1.2.1 FINAL. [Online: Excel spreadsheet] 2010. Available from: <http://archive.defra.gov.uk/environment/business/reporting/conversion-factors.htm> [Accessed 26th April 2011].
- [5] AEA. 2008 Guidelines to Defra's GHG Conversion Factors: Methodology Paper for Transport Emission Factors. [Online] London: Department for Environment, Food and Rural Affairs (DEFRA); 2008. Available from: <http://archive.defra.gov.uk/environment/business/reporting/pdf/passenger-transport.pdf> [Accessed 26th April 2011].

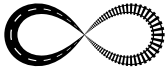

## NECESSITY TO SUPPORT THE FINANCING OF THE ROAD INFRASTRUCTURE

**Christophe Nicodème**

*European Union Road Federation (ERF), Belgium*

### Abstract

The European Union Road Federation (ERF) is a non-profit organisation which coordinates the views of Europe's road infrastructure sector and acts as a platform of dialogue and research on road mobility issues.

The ERF defends the interests of the European road infrastructure community towards the EU institutions and other stakeholders. It represents a cross-section of industry partners, road and road users associations active in the construction, equipment, maintenance and operation of Europe's road network.

It initiates and supports studies and publications aimed at increasing awareness on the importance of roads for all citizens; it also contributes to European research initiatives with the view of enhancing the overall efficiency and safety of the road transport system.

Among others, the ERF publishes every year the European Road Statistics, which compile a series of useful data related to the road infrastructure and transport within and outside Europe. These statistics address different topics such as Road Network, Road Safety, Sustainable Infrastructure, Goods and Passenger Transport, Infrastructure Financing and Road and Maintenance Investment [1].

### 1 Introduction

Road infrastructure is the backbone of the European economy and provides social equity, creating a source of unprecedented socio-economic wealth for Europe's citizens. To ensure the continued mobility of goods and people across Europe, it is essential to preserve and upgrade Europe's road infrastructure. In order to achieve this, it is necessary to raise the level of understanding of the fundamental role it plays.

With a total of 5.5 million km, the EU road network constitutes one of Europe's largest community assets.

However, chronic underfunding and lack of maintenance risk jeopardising in a short time this huge asset, which has been built over the past 50 years at great expense and effort. Roads, like buildings, need to be maintained and have their own life cycle, which can be prolonged efficiently if the timely corrective action is taken in an appropriate way.

We are now experiencing a critical point in time, where a continuation of status quo may entail a situation where our network is damaged beyond normal maintenance requirements and as such, would incur very costly actions to repair in the future and maybe even a permanent and irreversible partial loss of this important asset.

## 2 European Framework

In order to address the topic of Road Infrastructure Financing on a European prospective and in a global approach, it is convenient to insert it into the general framework of the European policy regarding transport and mobility.

### 2.1 The White Paper on Transport

In March 2011, the European Commission published the White Paper [2], which addresses the challenges and objectives for the preparation of the European Transport Area for the future. This document considers transport as fundamental for the economy and the society. It clearly states that mobility is vital for the internal market and for the quality of life of citizens as they enjoy their freedom to travel. It also underlines that transport enables economic growth and job creation and is essential for the free movement of persons and goods, as well as for the economic, social and territorial cohesion.

There is no possibility to accompany the future changes in transport without the support of an adequate network and a better and more intelligent use of it. Undoubtedly, the role of the transport infrastructure is fundamental.

If we look at the current situation of the road infrastructure within the EU, there are still many differences between the different Members States (EU-15 / EU-27), between countries with a mature, rather complete, almost sufficient road network and countries where the basic infrastructure is still missing.

The following map displays the motorway density in Europe in 2008 and we can see that differences are huge between countries.



Figure 1 Motorway density

## 2.2 The Trans-European Transport Network (TEN-T)

Most transport infrastructures in the EU were developed from a national point of view. In order to establish a single, multimodal network that integrate land, sea and air transport networks throughout the Union, the European policymakers decided to establish the trans-European transport network, allowing goods and people to circulate quickly and easily between Member States and assuring international connections.

By 2020, the growth in traffic between Member States is expected to double. The investment required to complete and modernise a well-performing trans-European network is substantial. The cost of EU infrastructure development to match the demand for transport has been estimated at over 1.5 trillion € for the period 2010-2030. The completion of the TEN-T network requires about 550 billion € until 2020 (mainly for the removal of bottlenecks).

Figure 3 shows the evolution of the TEN-T roads in length and type [4].

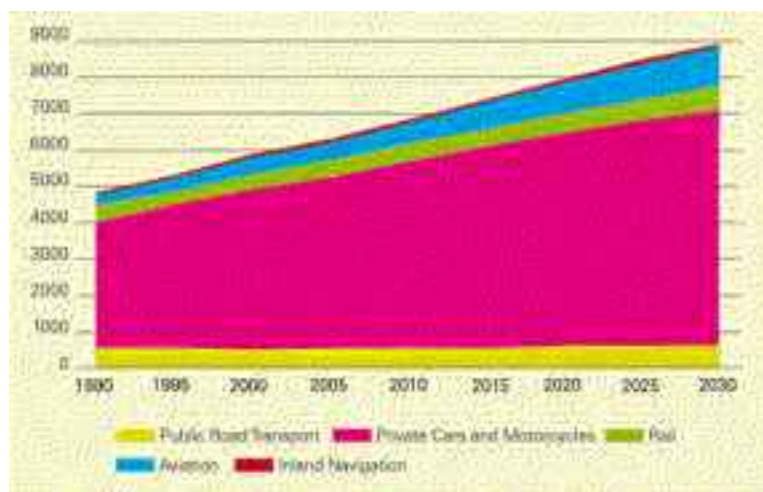

**Figure 2** Trends and outlooks in passenger transport demand for the different modes of transport in EU-25 (1990-2030) [3]

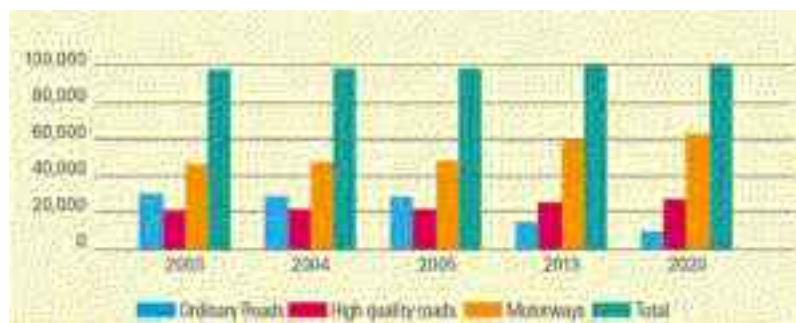

**Figure 3** Length and type of TEN-T Roads in EU-27

Given the scale of the investment required, it is necessary to strengthen the coordination dimension of network planning and development at European level, in close cooperation with national governments.



The European Union is supporting the TEN-T implementation by several financial instruments:

- the TEN-T programme
- the Cohesion Fund
- the European Regional Development Fund
- the European Investment Bank's loans and credit guarantees

In order to implement and manage the TEN-T programme on behalf of the European Commission, the Trans-European Transport network Executive Agency (TEN-T EA) was created in 2006. Figure 4 shows the Trans-European Transport Network and the TEN-T priority projects.

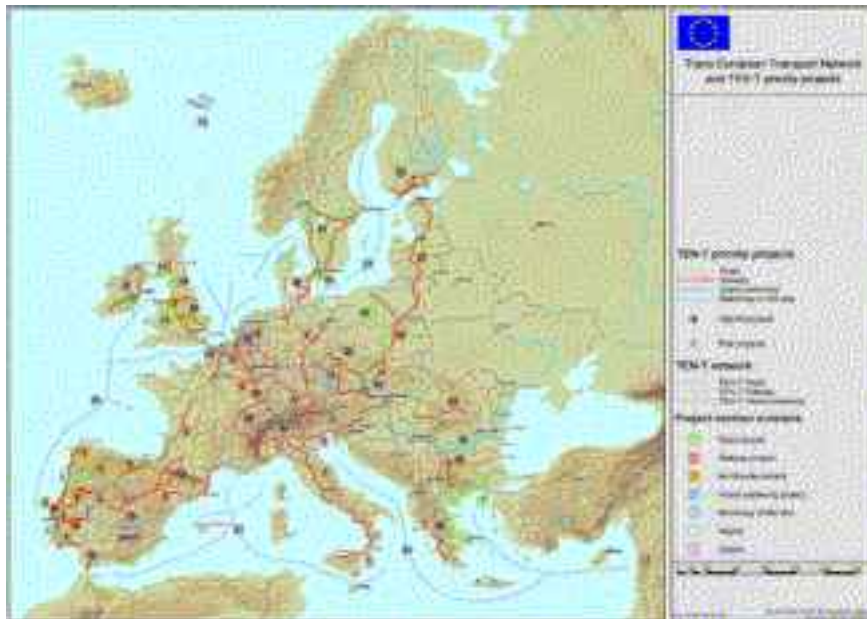

Figure 4 TEN-T priority projects

### 2.3 The European Road Safety Action Programme (RSAP)

Road safety is the major concern related to road transport and road infrastructure. In a global approach of the safety issue, the European Commission has elaborated an ambitious programme, aiming at halving the number of fatalities on the European road network over a period of 10 years [5].

#### 2.3.1 The Road Safety Action Programme 2001-2010

The objective of this programme was to reduce the number of fatalities by 50 % in 10 years (from 54000 to 27000 approximately).

The main characteristic of this programme was the principle of shared responsibility between all the stakeholders involved, i.e. authorities, private sector and road users.

It also developed a global approach, considering the 3 major pillars of Road Safety, i.e.:

- the vehicle
- the driver
- the infrastructure

It was also accompanied by the publication of the Road Infrastructure Safety Directive, which offered a series of useful tools aimed at improving the level of safety on the European Road

Network, among which the Road Safety impact assessments, the Road Safety Inspections and audits, the establishing of guidelines and the exchange of best practices. The following table shows the evolution of fatalities on the European roads.

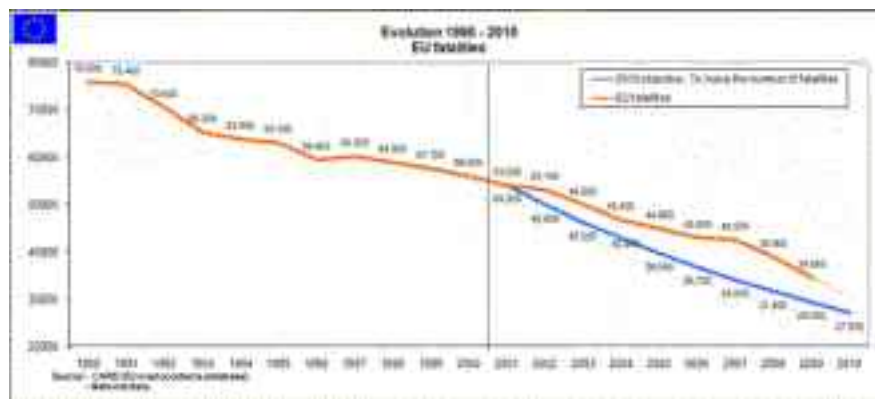

Figure 5 Evolution of fatalities on the European roads

As ambitious it was, this programme presented some weaknesses:

- the objective was very general
- there were some important differences between the countries in Europe in terms of Road Safety performance, mainly related to the current quality of the road infrastructure (EU-15 / EU-27)
- there was no tailor-made plan, which could have addressed the specificities of each country
- there was a lack of continuous monitoring
- the process of data collection needed to be refined. How can you, indeed, provide a clear picture of the situation when the processes of collecting data related to Road Safety are different from one country to another?

### 2.3.2 The Road Safety Action Programme 2011-2020

The 4<sup>th</sup> European RSAP tried to address some of the weaknesses of the previous one, by setting new priorities. Among these, the vulnerable road users (pedestrians, cyclists, motorcyclists), the consideration for an ageing population, the focus on the secondary road network ('rural roads') and the role of ITS for enhancing safety on roads.

## 3 The Road Infrastructure: an asset to preserve

Further to this brief consideration on the European prospective, it clearly appears that the road infrastructure has an essential role to play in the global framework of mobility and transport. It is the backbone of the economy; it provides general population with social equity, access to services, socio-economic wealth for citizens and mobility for goods and persons. It represents an asset which needs to be preserved and maintained. But how can we estimate the value of this huge asset? Some fundamental figures can help us.

### 3.1 Some figures

The Road infrastructure network in the EU represents 5.5 million of kilometres. The percentage of inland transport of goods by roads reaches 73.8%. The part of passenger transport inland represents 83.2%.

Directly or indirectly, in terms of contribution to the EU economy, the road transport sector employs approximately 14 million people and generates some 11% of the GDP.

### 3.2 Estimation of the road asset

When we talk about the asset that the road infrastructure represents, we would like to have an estimation of its value. This is a quite complex calculation, as there are many different approaches to carry out this estimation.

The ERF has started last year a Working Groups, gathering experts from all countries in Europe, in order to address the issue of the Road Asset Management, and one of the first tasks defined was to estimate the value of the road asset.

For this purpose, the first steps consisted in gathering data on the road network length in different EU and neighbouring countries, defining different types of roads:

- motorways and highways
- national roads
- regional roads
- rural roads
- urban roads

The following step consisted in determining an average value per km (it was decided to choose the average reconstruction value) for each type of road indicated. Then the final calculation would allow having an estimation of the value of the road infrastructure network in the specific country.

First observations: it was extremely difficult to get information on average replacement cost per type of roads in many countries and the definition of different categories of roads in each country could be quite different.

A further step consisted in obtaining information on the yearly expenditures in each country for the maintenance of the existing road infrastructure. This type of figures was even more difficult to obtain. Table 1 shows the format we used for collecting data. Table 2 shows the estimation that we obtained for the road infrastructure network in Croatia.

After analysing some of the information received, we observed that in general terms, the responsible authorities or road owners don't really have an idea of the value of their roads! As far as the money spent for its maintenance, this appears to be even more difficult to estimate. So without a clear estimation of these values, how can you establish a proper maintenance and preservation programme?

Table 1 Format for collecting data

COUNTRY		
Road Network (km)	Average construction cost per km (in M €)	Estimated value (in M €)
Motorways		
National Roads		
Regional Roads		
Rural Roads		
Urban Roads		
TOTAL KM	TOTAL VALUE	
Annual Expenditure		
Annual Value Loss		

**Table 2** Estimation for the road infrastructure network in Croatia.

COUNTRY			
Road Network (km)		Average construction cost per km (in M €)	Estimated value (in M €)
Motorways	1.250	8,5 M €	10.625 M €
National Roads	6.810	1,42 M €	9.670 M €
Regional Roads	10.820	1,1 M €	11.902 M €
Rural Roads	10.280	0,95 M €	9.766 M €
Urban Roads	*		
TOTAL KM	29.160	TOTAL VALUE	41.963 M €
Annual Expenditure		427 M €**	
Annual Value Loss			

\* Urban roads included in national, regional and rural roads

\*\* Financial funds, provide for approx. 60% of maintenance standard

### 3.3 Life cycle approach

Beyond the mere aspect of asset value, it is important to consider the road infrastructure through its whole life cycle. The approach must be systematic and take into account all the stages of the life of the road, from the conception and design, the construction, upgrading, operation and maintenance, to the replacement phase if necessary.

When the priority is given to the construction aspect, the initial investment has also to be considered with a longer term perspective, already taking into account the different phases to which the infrastructure will be submitted during its life. Every stage requires a proper, sufficient and responsible fund allocation.

Figure 6 displays a typical development of the value of the road capital (or asset) along the time.

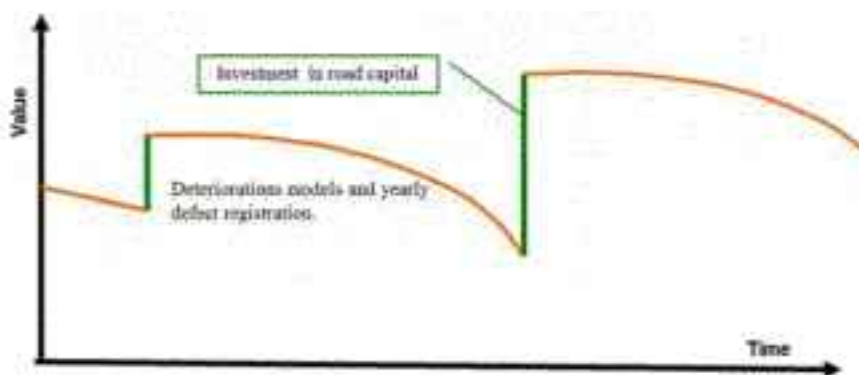

**Figure 6** The development of the value of road capital

It clearly indicates that the value of the road decreases with the time, until a certain investment is made in order to restore or increase the asset value, followed by a progressive loss of value. This cycle is continuous.

Through the whole life cycle of the road, any lack of investment has impact on the economy (loss of value), the safety (degradation of the infrastructure and its qualities) and the environment (major degradations can lead to increased congestion and urgent major work inter-

ventions can generate traffic disturbances increasing bottleneck effects, causing congestions and increasing the level of CO<sub>2</sub> emissions).

In all our countries, the current economic situation, the financial uncertainties and the monetary constraints have considerably reduced the availability of funds for all purposes. However, the underinvestment in the road infrastructure, particularly during the last 10 years, have led to a situation where our network is damaged beyond normal maintenance requirements, and as such, would incur very costly actions to repair it in the future and maybe even a permanent and irreversible partial loss of this important asset.

Figure 7 [6] displays the evolution of the road maintenance share of total road expenditure in various areas of the world, and we see that the trend is going down in Europe, particularly from 2006.



Figure 7 Road maintenance share of total road expenditure 1995-2009 (EUR) at current prices and exchange rates

Another evidence of the continuous decrease of investment into the road infrastructure is displayed in figure 8 [7].



Figure 8 Transport infrastructure investment model split in Western European Countries

According to a report published this year by Pro-Mobilität in Germany, the net asset value of regional, rural and urban roads in Germany has constantly decreased since 2003 (see figure 9).

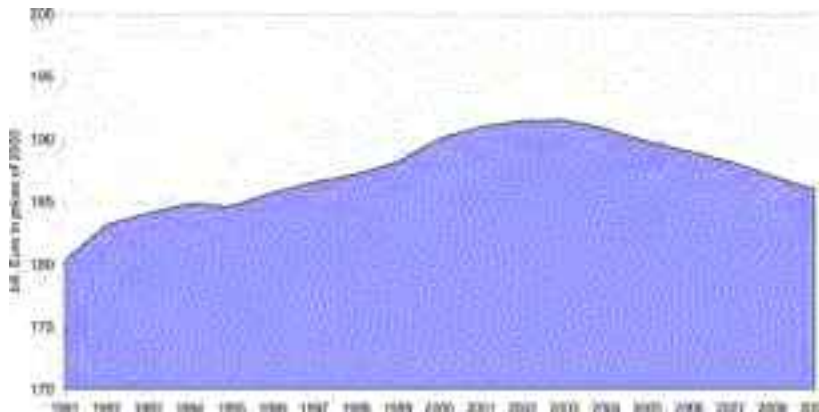

**Figure 9** New asset (value of time) of regional, rural and urban roads

With limited budgets available, the only solution is to carry out a global analysis of the condition of the road infrastructure, identify the priorities and make the necessary decisions, for prioritising funding, where the best return on investment can be found, while preserving and even increasing the asset value of the road infrastructure. This is the only way to maintain the necessary level of safety, mobility, sustainability and service to the road user.

Investing in the road infrastructure is the most cost-effective type of investment, with immediate results in terms of safety, for example. Figure 10 displays the major causes of accident on roads [8].



**Figure 10** US cost crash factor (\$ billion)

Easy and quick to implement solutions, by investing in the road infrastructure, can help reduce fatalities and increase safety and service to the user.

In the Netherlands, the Institute for Road Safety research (swov) produced a report entitled 'The Balance Struck: Sustainable Safety in the Netherlands 1998-2007' that evaluated the national road safety programme's success. During this period, the number of accidents decreased in total by 30%, decreasing, in real numbers from 1149 to 791. This resulted in more than 1700 lives saved as result of the new measures. This reduction was achieved by an annual investment of approximately € 530 m spent for road safety measures, € 350 m of which on road infrastructure. Assessing the cost-benefit ratio of measures, the report concludes that measures were socially cost-effective, with a cost-benefit ratio at 4:1 [9].

## 1.1 Financing

For many years, the financing of the major infrastructures, among which the roads, has been devolved to the national authorities. Most of the constructions have been financed by public expenditures, on the basis of tax leverage (circulation, vehicle, insurance or fuel taxes). However, in many countries, the level of taxes levied on the road transport and the road users, has reached a barely acceptable level. On the other hand, most of these taxes are not earmarked to the maintenance and improvement of the road infrastructure, but rather to compensate general public deficits, with a progressive degradation of the infrastructure versus an ever increasing tax collection.

Many countries have adopted the principle of concession motorways or highways. Generally speaking the principle of paying for the use of a well built, operated and maintained infrastructure is acceptable for the user, and on the safety aspect, statistics indicate that motorways account for the lowest fatalities on the entire road network.

Some other systems, based on the principle of 'pay per use' (vignettes, Eurovignette...) have also been introduced, under the principle of paying for the use and wear and tear of the infrastructure. However, these systems generally concern HGVs; the content of the elements taken into consideration (e.g. externalities, real use...) are not clear and some possible derogations lead to a confused implementation. Moreover, the money levied does not systematically get back to the maintenance and improvement of the road infrastructure, but rather to the financing of other modes of transport!

We should consider that a principle of road user charging should be fair and recognise the socio-economic importance of the road. It should not be an additional tax imposed on a heavily burdened sector and should be accompanied by the cancellation of some existing taxes. And last but not least, the revenues should be earmarked and transferred back to the road infrastructure, in order to offer to the road user a correct service in return.

## 4 The Mobility Bonus concept

As already indicated, the issue of the financing of the road infrastructure remains a major concern nowadays, especially during these difficult economic times.

This is why the current limitation in budgets available requires some new, original and innovative approaches, in order to ensure the preservation and maintenance of a road infrastructure that can deliver the levels of mobility, quality, safety, sustainability and service that the road user is expecting and deserves to receive.

In this context, the Asociación Española de la Carretera (the Spanish Road Association) has developed a new concept, which is called 'Bono de Movilidad' (Mobility Bonus).

### 4.1 Principles

During the 80's and 90's, Spain has experienced an important development of its road infrastructure, mainly thanks to the EU funds. But since the 90's a systematic lack of investment for proper maintenance of the infrastructure (under the competence of the public authorities) has led to cumulative deficits in the road transport budget, a loss of quality and value of the infrastructure and resulted in negative impacts on mobility and service to the user.

This situation led the AEC to make an innovative proposal, based on a consistent and integrative model, and which is not an additional tax, nor a type of 'Eurovignette'.

### 4.2 Summary of the Proposal

The proposal is linked to the over-use of the network beyond a determined medium standard. It consist of a free circulation allowance for all vehicles on the whole network of the country (except motorways on which a toll system is applied), and this until a certain mileage.

Further to different researches, the free allowance thresholds proposed are the following:

- 15000 km/year for vehicles < 3.5 T
- 100000 km/year for vehicles > 3.5 T

The control of the distance covered would be made using an On Board Unit (OBU) linked to a bank account.

Any additional kilometre (beyond the free allowance) would be charged according to variable criteria, such as the time of the day (night/day, peak hour...), the vehicle, the cost of the infrastructure used, the service level and the road type.

Price per km should vary between 0.075€ and 0.12 €.

The final objectives of the proposal are:

- To cancel deficits in road infrastructure budget
- To foster the investment for the whole network, taking into account social, environmental and territorial criteria
- To improve the information and the service to the road user
- To improve traffic flow and mobility
- To improve the infrastructure and the equipment

Some considerations have been taken into account for the development of this project:

- The social acceptance of the system requires a service in return
- It must be applied on the whole network, in order to avoid shifting effect
- The road programme budgets must include minimum required standards
- The surplus must be used for eliminating deficits in the road transport budget and improving the infrastructure
- A Management Agency is required to operate the system.

### 4.3 Financial estimation

The estimated global revenue of the system of Mobility Bonus should be around 20 billion € per year.

The management cost (Agency) would represent approximately 1 Billion € per year (or 5% of the total revenue).

The OBU cost should be around 50 € per unit.

### 4.4 Examples in practices

Example 1:

passenger car – 20.000 km / year

Free allowance: 15000 km

Over mileage: 5000 km

Cost / year: +/- 375 €

Example 2:

HGV – 150.000 km / year

Free allowance: 100.000 km

Over mileage: 50.000 km

Cost / year: +/- 5000 € approx.

This proposal is obviously not an ultimate solution. But it has the merit of considering the issue of road mobility, transport and infrastructure financing in an innovative and integrative approach, with a focus on an intelligent earmarking process.



## 5 Conclusions

The future development of the demand for transport and mobility is expected to expand in an exponential way during the years to come. The prosperity and welfare of the citizens largely depend on our commitment to offer them a sufficient, reliable, efficient and sustainable infrastructure, capable to cope with the future mobility requirements.

Road transport already plays an essential role in the global framework of mobility and will continue to do so. However, lack of interest from many decision makers in the recent past has led to a critical situation, where the current infrastructure incurs a dramatic decline in terms of quality and efficiency, with the risk of irreversible loss of financial value, and related consequences in terms of service, safety and sustainability.

The financial resources available are rather low and require a necessary prioritisation of the expenditure schemes. But the money needed for the preservation and the maintenance of the road infrastructure must be considered as an investment for future prosperity and socio-economic added value for the whole society.

It is necessary to address this issue with innovative and original perspective, and to find new solutions to prevent the road infrastructure from losing its essential value of economic asset, connection, service, integration and mobility for the users.

We can not afford to put our future growth and prosperity in danger and compromise with our freedom of movement.

## References

- [1] <http://www.erf.be/images/stories/Statistics/2011/ERF-2011-STATS.pdf>
- [2] <http://eur-lex.europa.eu/LexUriServ/LexUriServ.do?uri=COM:2011:0144:FIN:EN:DOC>
- [3] <http://www.erf.be/images/stories/Statistics/2011/ERF-2011-STATS.pdf>
- [4] <http://www.erf.be/images/stories/Statistics/2011/ERF-2011-STATS.pdf>
- [5] [http://ec.europa.eu/transport/road\\_safety/pdf/com\\_20072010\\_en.pdf](http://ec.europa.eu/transport/road_safety/pdf/com_20072010_en.pdf)
- [6] <http://www.erf.be/images/stories/Statistics/2011/ERF-2011-STATS.pdf>
- [7] [http://www.erf.be/images/stories/RRS\\_Policy\\_Statement\\_final\\_23\\_March\\_light.pdf](http://www.erf.be/images/stories/RRS_Policy_Statement_final_23_March_light.pdf)
- [8] [http://www.erf.be/images/stories/RRS\\_Policy\\_Statement\\_final\\_23\\_March\\_light.pdf](http://www.erf.be/images/stories/RRS_Policy_Statement_final_23_March_light.pdf)
- [9] De balans opgemaakt : Duurzaam Veilig 1998-2007, SWOV, 2009  
[http://swov.nl/rapport/Balans\\_10\\_jaar\\_DV.pdf](http://swov.nl/rapport/Balans_10_jaar_DV.pdf)

# 1 EDUCATION



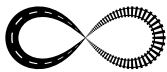

## RESEARCH ON COMPETENCES OF STUDENTS OF CIVIL ENGINEERING STUDIES IN THE FIELD OF ROAD CONSTRUCTION

Zlata Dolaček–Alduk, Sanja Dimter

*Josip Juraj Strossmayer University of Osijek, Faculty of Civil Engineering, Croatia*

### Abstract

At the Faculty of Civil Engineering Osijek, as in the whole Croatian higher education system, the introduction of learning outcomes and the development of study programmes based on learning outcomes are at the very beginning. Learning outcomes help students, since they clearly describe what is expected from them during the course of their studies. They also help teachers to focus exactly on the desired level of knowledge and skills of students in a particular course. One of the important elements for defining the approach to education based on learning outcomes are data on desirable competences of graduates, which are attained by interviewing employers, graduates, and teachers. The concept of competence includes knowledge, skills and attitude through which an individual is qualified to carry out a particular job. Competence, in that sense, represents a combination of knowledge and its application (skills), attitudes and responsibilities, which reflect the learning outcomes of the educational programme. Replies of interviewed employers should be used for an analysis of the employment process of the Faculty's graduates' and the employers' satisfaction with graduates' acquired knowledge and skills, as well as the possibility to apply them during work. The interview survey should reveal the deficiencies in the educations of students, and which knowledge and skills are missing, according to employers. The employer survey results will be combined with the results of graduate survey. This will serve to improve the organization and content of courses (modules) or the entire programme. In this paper, employers whose activities are primarily in the field of road construction will be interviewed. Also, students of undergraduate and graduate studies will be interviewed in order to determine the perception of the importance of competences, skills and attitudes acquired during the course of their studies.

*Keywords: competences, graduate students, learning outcomes, employers*

### 1 Introduction

According to the Communiqué of the Conference of European Ministers Responsible for Higher Education (Draft 2, January 2012) the implementation of learning outcomes and student-centred approach will be the key focus until 2015 [1]. Ministers' ambition is that learning outcomes become a reality of daily student experience as part of student centred learning process. Student-centred approach means that the curriculum is developed based on a set of required competences [2]. For the student, competence means to be able to perform skills and knowledge in order to solve a given problem.

The term competence is used to display a combination of attributes in terms of knowledge and its application, skills, responsibilities and attitudes in an attempt to describe to what extent a person is able to perform them. Definition of competency, which is generally accepted in the countries involved in the Bologna process, is given in a publication of Tuning project Tuning Educational

Structures in Europe, to which competences represents a dynamic combination of knowledge, understanding, skills and abilities [3].

The combination of individual features in terms of knowledge and understanding (theoretical knowledge in the academic field, the capacity for knowledge and understanding), know how to act (practical application of knowledge in certain situations) and knowledge of how to be (values as integral elements of perception and ways of life with others in a social context) allow competent performance and describe the level or degree to which an individual will be able to use them [4]. To develop the student's specific competences it is necessary to determine required knowledge, the necessary skills to apply that knowledge, attitudes needed for subject matter knowledge, methods and procedures which will be achieved, the method of evaluation and achievement of competencies and required instructional media. The starting point for planning the educational process is to determine the competency of graduates (competence based curriculum). In higher education competences are developed in all course units and assessed separately for each level of study programs [5]. Competences are formed in a variety of lessons and achieved at various levels. They can be divided according to subject (specifically to the program of study) and generic competences (common to any degree course) [6].

### 1.1 Division of competences

The division of competences arose from the need to identify how their acquisition and to facilitate identification (check) of their possession. Tuning project classifies competences into two broad categories: the subject–area related competences and generic or transferable competences.

Subject–area related competencies are crucial for any degree and they are intimately related to specific knowledge of a field of study. They are closely associated with one particular area and are also called academic competence. They form the core curriculum and are included in each training cycle. Professional competences are those relating to the relevant methods and techniques specific to particular disciplines. Professional, theoretical and practical knowledge includes content, factual knowledge about the area, the ways in problem solving, knowledge of area history and contemporary developments.

Generic (general) competences are shared attributes which could be general to any degree. Generic competencies are a set of knowledge, skills and values that are widely used in various fields of activities and allow for adjustments to a variety of highly skilled jobs. Generic or general competencies are becoming increasingly important in preparing students for their future social role. There are three types of general or generic competencies:

- instrumental competences that include:
  - cognitive abilities – capacity to understand and manipulate ideas and thoughts
  - methodological capabilities – capacity to manipulate the environment organizing time and strategies of learning, making decisions or solving problems
  - technological skills – capacity to use of technological devices, computing and information management skills
  - linguistic skills – oral and written communication or knowledge of a second language.
- interpersonal competences – Individual abilities relating to the capacity to express one's own feelings, critical and self–critical abilities. Social skills relating to interpersonal skills or team–work or the expression of social or ethical commitment. These tend to facilitate processes of social interaction and of co–operation
- systemic competences – those skills and abilities concerning whole systems. They suppose a combination of understanding, sensibility and knowledge that allows one to see how the parts of a whole relate and come together. These capacities include the ability to plan changes so as to make improvements in whole systems and to design new systems. Systemic competences require as a base the prior acquisition of instrumental and interpersonal competences.

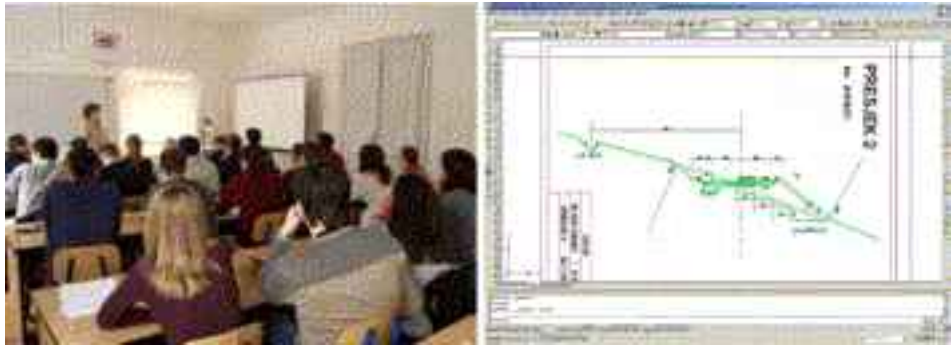

Figure 1 Classroom work: lectures (left) and exercises (right)



Figure 2 Field work and field visits

With the aim of acquiring competencies during the study educational activities can range from lectures (Figure 1.), seminars, research seminars, exercises, laboratory work, guided individual work, independent study, practice, field work (Figure 2.), project work and the like.

## 2 Competences for the labour market

An important motive for the reform of higher education is to focus on developing graduates' competencies necessary for the labour market. Changes in higher education study program focuses on developing competencies needed labour market and to establish links with the community. Employability of graduates, including self-employment through entrepreneurship, is to be enhanced through continuing adjustments of education programmes and the use of learning outcomes as tools for improved dialogue between higher education institutions (HEI's), students and working life. Higher education must contribute to unlock regional resources, as HEI's are encouraged to work with the widening of local enrolment and the continuous upgrade of the regional workforce. Student-centred learning and life long learning (LLL) must be promoted.

Study program development should take into account an overview of both main EU policies concerning regional policies and higher education and Croatia 2008 Progress Report as well as strategic documents of Eastern Croatian counties. Strategy for the development of the Osječko-baranjska County acknowledges higher education as an important element of social and economic growth; its development is ranked third in importance out of ten key

strategic directives. In the chapter Knowledge is everything the strategy establishes a direct link between education, county level government and economy as a condition for progress and regional competitiveness.

## 2.1 Construction sector in Eastern Croatia

Civil engineering higher education institutions and construction industry in Croatia currently coexist and function independently. This leads to a gap between competencies of civil engineering graduates and labour market needs. It is necessary to connect higher education and industry sector in Eastern Croatia through a sustainable infrastructure that enables continuous communication, collaboration and mutual impact. This socially responsible partnership in the design and delivery of education should result in higher quality of the engineering profession in the region, giving Eastern Croatia a comparative edge in the construction business. In the last five years, construction market in Eastern Croatia employed almost all civil engineering university graduates offering them a variety of jobs, respected positions and good financial deals. Due to legal restrictions, employers were interested mainly in their diplomas and somewhat less in the quality of their qualifications. But, current global crisis hit the construction sector hard in 2010, forced it to downsize and steeply reduce the number of job offers. So, for the first time, civil engineering graduates encountered unemployment as an option to reckon with. Suddenly, specific knowledge and skills emerged as a highly important element of employability. At the same time, no communication channels were established between higher education institutions and the construction industry so the content of these knowledges and skills was only to be assumed.

## 3 Students' competences of civil engineering studies

During this period, study programs have been transformed a number of times, mostly due to administrative or organizational changes. First generation of students studying according to the Bologna process enrolled in 2005 following a three level study system. This shift in higher education in Croatia required major study changes, but, although it presented an opportunity to rethink civil engineering education based on learning outcomes, competences, collaboration with employers in the construction industry and other graduates' market options. At the same time employers are not aware of changes due to Bologna process but they are dissatisfied with skills and abilities of recent graduates. There is a silent consensus that employers are not at all involved in the upon employment that they have a broad knowledge of civil engineering matters but that they lack some generic competences and soft skills. In the process of Croatia's accession in the European Union, our graduates' employability is threatened by work force from other European nations.

With the aim of improving academic programs there was a questionnaire based research on the desirable competencies of graduates study civil engineering at the University of Osijek. Research was conducted from the perspective of civil engineering students – which competencies are considered to have achieved during the study and from the standpoint of employers – to evaluate the competency of graduates.

The questionnaire was taken from the project 'Learning outcomes in higher education of civil engineers', which was conducted at the Faculty of Civil Engineering Rijeka in 2010 [7]. The list of competencies that are offered in the questionnaire was based on data downloaded from European Civil Engineering Education and Training (EUCEET) web site networks and criteria of accreditation of engineering study of the American Association for quality assurance of engineering studies (ABET) tailored to the needs of research [7]. Students and employers are assessed through a questionnaire to what extent the study develops specific and general competences.

### 3.1 Subject–area competences

The research results (Figure 3.) show that students as a least developed competence (score: a lesser extent acquired the partially acquired) emphasize the ability to understand the elements of the construction project and the ability to build complex structures, the ability to identify, define and solve engineering problems and the ability to identify the required additional research and resources needed. As the best–developed competencies, students assessed the ability to apply knowledge in areas relevant to the basic construction, understanding of professional and ethical responsibilities and understanding the needs and readiness for involvement in a program of lifelong learning.

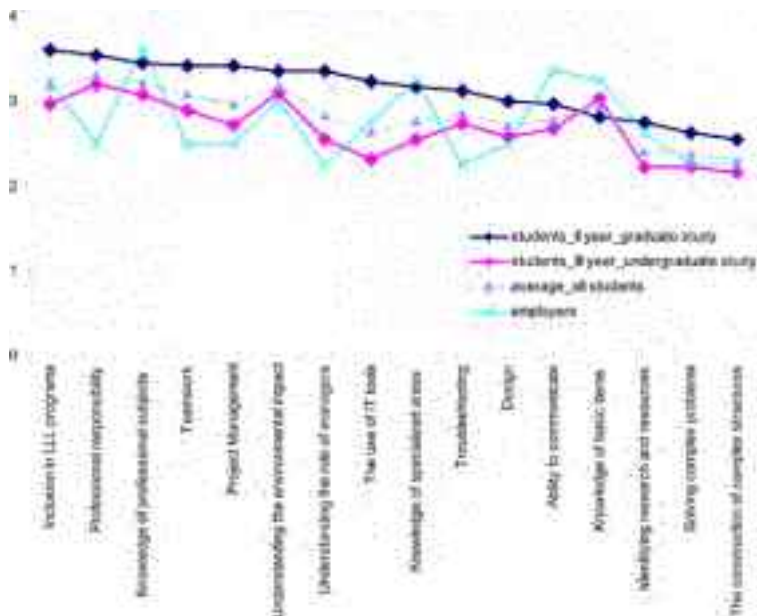
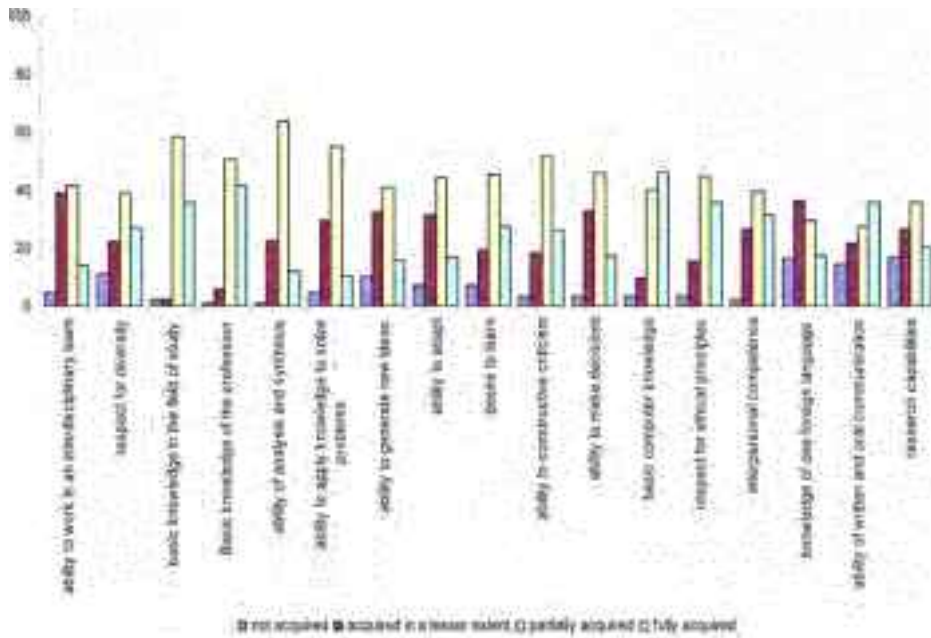

Figure 3 The results of the research assessment of the level competencies that students develop during their studies at the Faculty of Civil Engineering Osijek

### 3.2 Generic competences

The research results within the Tuning project and the project 'Systematic approach to the introduction of learning outcomes in the education of students at the Josip Juraj Strossmayer University of Osijek' in which the opinions of employers say tested generic or general competence as equally important or even more important for success in business [8]. Nevertheless, the study programs neglect the acquisition of these competencies and their development. Introducing the explicit reference to the acquisition of general competencies in curricula would represent a significant shift towards recognizing and understanding the needs of the labor market for professionals who can easily fit into the different and changing work environments.





**Figure 4** The results of the research assessment of the level competencies that students develop during their studies at the Faculty of Civil Engineering Osijek

The research results (Figure 4.) show that students as a least developed competence during studies emphasize the knowledge of one foreign language, ability to written and oral communication and research capabilities. As partially acquired they evaluated ability of analysis and synthesis, basic knowledge in the field of study and ability to apply knowledge to solve problems.

## 4 Conclusion

The study found that there are discrepancies in the opinions of employers respect to the students' opinion. Employers generally give better ratings to the students' competences for professional and technical competence that can be explained by a careful recruitment policy, where more attention is paid to the knowledge and skills of candidates, rather than terms such as creativity and knowledge of foreign languages.

It was noted that there are competencies that employers are very highly valued, and that the Faculty of Civil Engineering Osijek has not put enough emphasis in our program. This is the development of generic competence (rational thinking and independence in decision making, ability to select information, the ability of analysis and synthesis) and development of call attitude towards the profession.

The results indicate that the development of academic programs and the acquisition of general competencies should be balanced with the acquisition of professional competence with regard to their importance in employment.

## References

- [1] Communiqué of the Conference of European Ministers Responsible for Higher Education, Bucharest, 26-27 April 2012, Draft 2, 10 January 2012
- [2] Schreurs, J., Al-Huneidi, A.: Development of a learner-centered learning process for a course, 14th International Conference on Interactive Learning (ICL2011) – 11th International Conference Virtual University (vu'11), Piešťany, Slovakia, 21-23 September 2011, Conference Proceedings, page 256-263
- [3] Gonzales, J., Waagenar, R. (ur.): Uvod u projekt Usklađivanje obrazovnih struktura u Europi: Sveučilišni doprinos Bolonjskom procesu, Socrates-Tempus, 2006
- [4] Vizek-Vidović, v. (ur.): Planiranje kurikuluma usmjerenog na kompetencije u obrazovanju učitelja i nastavnika, kompetencije i kompetencijski profili u učiteljskoj i nastavničkoj profesiji, Filozofski fakultet Sveučilišta u Zagrebu, Zagreb, 2009
- [5] Agency for Science and Higher Education: Glossary of basic terms and definitions in the field of quality assurance in higher education, Zagreb, 2007
- [6] Vodič za korisnike ECTS-a, Glavna uprava za obrazovanje i kulturu, Bruxelles, 2004
- [7] Deluka-Tibljaš, A., Karleuša, B., Štimac Grandić, I.: Definiranje ishoda učenja na studijima građevinarstva Sveučilišta u Rijeci, Građevinar 63 (2011) 1, strana 1-10
- [8] Lončar-Vicković, S., Dolaček-Alduk, Z.: Ishodi učenja – Priručnik za sveučilišne nastavnike, Sveučilište Josipa Jurja Strossmayera u Osijeku, Osijek, 2010



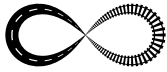

## NEARLY 10 YEARS OF TEACHING RAILWAY SIMULATION AT THE VIENNA UNIVERSITY OF TECHNOLOGY

**Katalin Jurecka**

*Vienna University of Technology, Institute of Transportation, Austria*

### Abstract

Railway simulation is a powerful tool for answering various questions in railway network planning and analysing different solutions. Today, railway simulation is used by railway operators, consultants and universities. At the Vienna University of Technology the course Railway Simulation is part of the curriculum since 2003. The focus of this article is to give an insight into this course and to show its successful application.

The course Railway Simulation is offered at the Research Centre for Railway Engineering, Traffic Economics and Ropeways of the Institute of Transportation at the Faculty of Civil Engineering. The course is open to all students at the Vienna University of Technology but it is especially aimed at students studying civil engineering during their Master studies who have gained an overview of railway engineering in their Bachelor studies.

The aim of the course is to give an insight into railway operation. The course is divided into two parts. The first part is an introductory lecture to repeat the main terms of railway operation and the basic software elements. In the second part the students work with the railway simulation software OpenTrack (by OpenTrack Railway Technology Ltd., Switzerland) to solve various tasks. For example, one task is to determine the travelling time and the minimum headway time of different trains on a given infrastructure. Another task is to identify how track improvements can influence the travelling time and to develop a fixed interval timetable for a given infrastructure.

Overall, there is a good interest in this course and this course is very useful for the students to understand the specific characteristics of railway operation.

*Keywords: railway simulation, running time, timetable, education, fixed interval timetable*

### 1 Introduction

Since 2003 the Research Centre for Railway Engineering, Traffic Economics and Ropeways of the Institute of Transportation at the Faculty of Civil Engineering at the Vienna University of Technology (Austria) offers the course Railway Simulation. The course has been created to enable students to answer questions of railway operation with the help of simulation software.

#### 1.1 Admission to the course

The course is open to all students at the Vienna University of Technology, but it is especially aimed at students studying civil engineering during their Master studies who have gained an overview of railway engineering in their Bachelor studies. Approximately 45 students attended the course each semester in the past three years. Most of students are studying civil engineering, but there are also students from other Bachelor and Master programmes at the Vienna University of Technology (e.g. mechanical engineering, computer science). The course

is offered in German, but can be taught in English as well, as the language of the user interface of the software used in the course is in English.

There are no restrictions to take the course, although a basic knowledge of railway engineering is helpful. As the students have differing previous knowledge, there is an introductory lecture at the beginning of each semester in order to reach the same level of knowledge for every student at the course. This introductory lecture is on the one hand a repetition for the civil engineering students and on the other hand probably new information for the other students. In the introductory lecture the basic principles of railway operation are explained with a special focus on the tasks that will be given to the students during the course.

## 1.2 The introductory lecture

The aim of the introductory lecture, as well as of the whole course, is to teach students the basic terms of railway operation. According to technical literature (see [3]) there are two main characteristics of railway transportation. One main characteristic is track guiding and the other is the fact that the braking distance exceeds the viewing range of the driver because of the coefficient of adhesion between steel wheel and steel rail [2]. These characteristics, that are significantly different from road traffic, influence the design and operation of railways. Because the stopping distance is generally longer than the range of vision, train separation by the sight of the driver is not possible. Therefore railway tracks are divided in block sections with fixed signals so that train separation is done through fixed block distances. Only one train can occupy a block section exclusively. Therefore a train must not enter a block section until that section has been cleared by the train ahead [2].

## 2 Software OpenTrack

In the course, the students use the software OpenTrack representatively for other simulation software. During the simulation, predefined trains run on a railway network according to a timetable [1]. To conduct a simulation, the software OpenTrack needs the following three components: rolling stock, infrastructure and timetable (see Fig. 1). While in this course the components infrastructure and rolling stock are already given, the students only work with the timetable component (see grey label in Fig. 1) containing the tools courses, timetable and simulation.

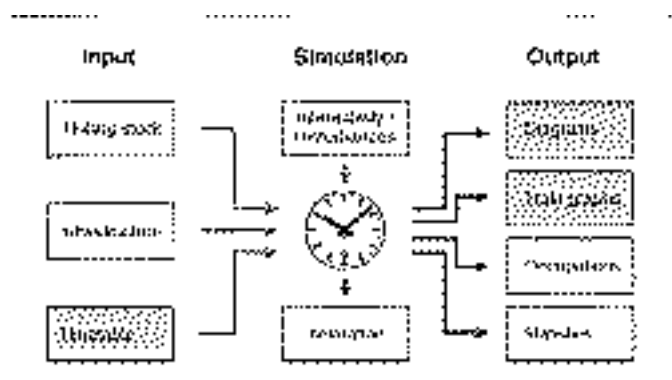

Figure 1 The components of the simulation [1]

In the following subsections, the two given components infrastructure and rolling stock are described.

## 2.1 Infrastructure

In the tasks given for the students, the infrastructure is already defined. The students work with two different infrastructures. Both infrastructures are single track and are based on existing railway lines in Austria, but are simplified for the use of this course. The first infrastructure is simplified as a single line section because that is sufficient for the purpose of the tasks. Whereas the second infrastructure has additional tracks in some stations to allow trains to overtake and cross each other (see Fig. 2). The first infrastructure is about 300 km long; the second infrastructure is 25 km long. The trains are governed by fixed signals along the track (main and distant signals).

## 2.2 Rolling stock

The rolling stock, like the infrastructure, is also already given. The rolling stock database contains about 30 different trains ranging from high-speed trains to regional trains and freight trains.

# 3 Tasks

The tasks for the students are created to point out the characteristics mentioned in subsection 1.2. The students work in groups of two with a computer at the institute where the software is installed. After a short introduction into the relevant functions of the software, the students start working by themselves. After each task the results are being discussed together with the teaching assistant. The students work on five to seven different tasks, where they have to determine running times, determine minimum headway times and create fixed interval timetables. The tasks do not include operational aspects such as delays, connections or timetable stability analysis because these aspects would go beyond the scope of this course. The basic requirement of all these tasks is that the trains run without any conflict between the different train paths. Therefore the students create time-distance diagrams with blocking time stairways to show that the timetables they have created have no conflicts between the different train paths.

In the following subsections, five selected tasks are described.

### 3.1 Running time calculation

In the first task, the students have to determine the running times of different trains on a given infrastructure. This task serves also to introduce the students how to use the software tools courses, timetable and simulation. The students learn how to define a course, to choose an itinerary for it, to enter a timetable and to start a simulation. For the running time calculation the students choose ten different trains out of the rolling stock database. The students create speed-distance diagrams for each train simulated to see the maximum speed and the braking and acceleration curve of the train. Furthermore, they create time-distance diagrams to display the blocking time stairways.

### 3.2 Influence of train stops on running time

In the second task, the students have to conduct several simulations with the same train on the infrastructure given before in order to find out how additional stops influence the running time.

### 3.3 Time savings due to higher maximum speed

In the third task, the students have to improve the given infrastructure by setting a higher maximum speed in a specified track section. Then the students compare the running times of different trains before and after the improvement.

### 3.4 Fixed interval timetable for regional trains

The following tasks are performed on the second infrastructure with additional tracks in some stations to allow trains to overtake and cross each other (see Fig. 2). In the fourth task, the students have to create a fixed interval timetable for a regional train (see Fig 3). Unlike in the tasks before, where the trains were only going into one direction, in this task the trains go in both directions and can overtake and cross each other at the stations.

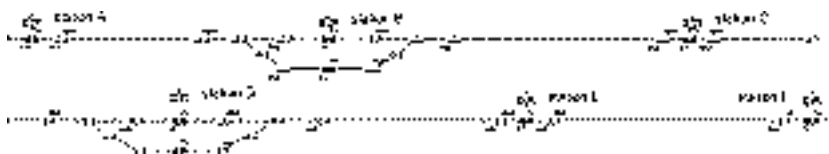

Figure 2 Screenshot of the second infrastructure

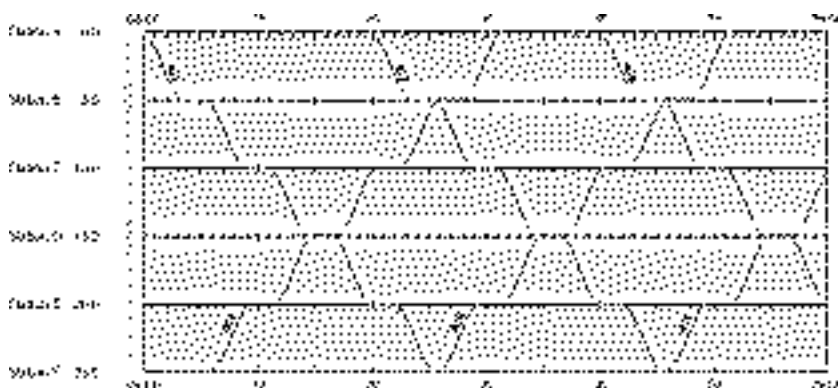

Figure 3 Screenshot of a time–distance diagram for a fixed interval timetable

### 3.5 Minimum headway time calculation

In the fifth task, the students have to determine the minimum headway time between slower and faster regional trains in order to understand the principle of signalling by displaying the blocking time stairways.

## 4 Outlook

After this seminar, some of the students continue working with railway simulation in a compulsory interdisciplinary seminar or master's thesis. Possible tasks for the interdisciplinary seminar are to optimise either an existing railway track or an existing time schedule. The students create all required input data by themselves that are rolling stock, infrastructure and timetable. Sometimes it is possible for the students to carry out a simulation in cooperation with a railway operator company.

Overall, also in the upcoming semester there is a good interest in this course and this course is very useful for the students to understand the specific characteristics of railway operation.

## References

- [1] OpenTrack.Info\_E.pdf, <http://www.opentrack.ch/opentrack/downloads/opentrackInfoE.pdf>, 29.02.2012
- [2] Hansen, I.A., Pachel, J., Railway timetable & traffic, First edition, Eurailpress dvv Rail Media, Hamburg, 2008, p. 12
- [3] Pachel, J., Systemtechnik des Schienenverkehrs, Fifth edition, Vieweg+Teubner, Wiesbaden, 2008, p. 1, in German





## 2 TRAFFIC PLANNING AND MODELLING



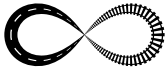

## THE ROLE OF A POLICY MADE ROAD CATEGORISATION FOR SUSTAINABLE ROUTE NAVIGATION UNDER NORMAL AND CONGESTED TRAFFIC CONDITIONS

Koen De Baets

*Ghent University, Institute of Sustainable Mobility (IDM), Belgium*

### Abstract

Travellers can reach a destination easily and fast by using navigation systems and route planners, which are often able to dynamically adjust a route according to changing traffic conditions. However, navigation systems primarily focus on the interests of the individual road user. Too often, the impact on safety and liveability along the suggested routes is neglected. Policy makers aim at a sustainable use of the road network with a focus on public interest, rather than on the individual profit of a navigation system user. To avoid improper use of the road network, many countries have developed a functional road categorisation. In the Flanders region this was defined in the Flemish Spatial Structure Plan (RSV 1997).

This research examines to what extent the route planners induce improper road use. Several route planners are used to calculate routes between origins/destinations relations. Between each relation exists a preferred sustainable route. The routes suggested by route planners are compared to the corresponding preferred route, after which the road classification usage of route planners can be evaluated. Routes are calculated under normal (static) and congested (dynamic) traffic conditions. The in-depth analysis of this research indicates an over-(mis) use of local, in particular in a congested road network. It is concluded that the implementation of the Flemish road categorisation in route planning has the potential to stimulate a more sustainable route choice, but does not provide a sustainable alternative route if congestion occurs. The categorisation system itself needs a critical review, especially in congested areas.

*Keywords: route planning, dynamic route planning, navigations systmes, traffic liveability, road categorisation*

### 1 Introduction

Recently, the use of navigation systems and route planners has increased. These systems are capable of guiding travellers to their destination by presenting the most appropriate route to the user, and even information to avoid traffic can be included [1]. However, if the navigation system suggests roads that are not intended to be used by through-traffic, they might put at risk the liveability and safety of the environment. It is not clear to what extent the available route planners take into account the traffic annoyance they may cause by their suggested routes.

In the Flanders Spatial Structure Plan (RSV)[2] a functional road categorization is introduced. The basic principle is to selectively prioritize the roads by 'giving access' or 'liveability'[3]. By applying this policy-made road categorization, a routing methodology that is preferred by policy makers can be developed and the liveability of neighbourhoods can be protected [4]. However, digital maps suppliers use a different, usually private road categorization based on functional importance and road characteristics [5]. A comparison between the preferred (RSV) routes (as indicated by the policy makers) and the (fastest) route from route planners seems

necessary. This study examines to which extent route planners take into consideration the principles of the RSV road categorization to determine a route choice. This is done by examining the categories of roads that are used to travel from origin to destination by using route planners and by using a preferred RSV-based route. This study will consider both static routes and time dependent routes. The latter implies that routes may vary depending on time and day of the planned trip. This paper will first explain the principles of the road categorization according to the RSV. Secondly, the study describes and elaborates on the available technologies. Next the methodology used for comparing static routes is explained, followed by the similar methodology used for comparing time dependent routes. Finally, some conclusions are given.

## 2 Network and road categorisation

The existing road categorization of the Flanders Spatial Structure Plan is based on selectively prioritizing either accessibility or liveability. Within the road network in Flanders four categories of roads are distinguished: the main road network, primary roads, the secondary and the local roads. Three main functions are distinguished on functionality: the connection function, the collection function and the function of giving access [2] (Afdeling Ruimtelijke Planning, april 2004). A main function and a complementary function are assigned to each category. In addition a distinction is made between three hierarchical levels (International, Flemish, (super-)local) depending on the relation between origin and destination.

On the highest level, the road network must be consistent. Roads of Flemish and (supra-)local level do not need to form a coherent network. They do have to form a coherent road network with the higher level network on which they are connected via links. This creates a tree-like structure with branches to lower levelled roads [6]. The underlying idea of the tree is to avoid connections within a mesh, which would start to function on a higher level. The traffic flow at various levels must be in proportion so that the lower levelled road network does not get overloaded by through-traffic ('cut-through traffic') and that the road network of higher level is not loaded with traffic at a subordinate relationship ('improper road use').

## 3 Navigation functionalities

Route planning allows calculating an optimal route between two locations, depending on the available data. To generate these routes, two aspects are indispensable: the data including the road network with additional information to guide vehicles efficiently through the road network, and a process or algorithm to calculate a suitable route based on the available data. Depending on the source data, a wide variety of criteria can be taken into consideration while calculating a route. The quality of the route depends on several factors such as distance, travel time, number of turns, traffic lights, dynamic traffic information and even aspects that may ensure traffic liveability. Together these factors make a total trip cost. The routing algorithm will attempt to minimize this travel cost. Classic route planners and navigation systems are static in calculating routes. Based on the user's preference (fastest, shortest), only one route will be presented which will not vary over time (not considering the possibility of map updates). Recent technologies go beyond these static routes, and include time dependant information. This implies that route suggestions may vary depending on time and day of the planned trip. The least recent system is TMC. TMC [7] is the abbreviation of 'Traffic Message Channel' and can send digital information concerning traffic conditions at a limited amount of locations, with a delay of approximately 5 to 15 minutes after the incident took place. New technologies such as the tracking of vehicle location, by GPS signal or by mobile phone signal provided by telecom operators, allow the calculation of travel times based on real traffic data. The collected data is used to recommend routes with a more accurate time of arrival expectations depending on the time of day and day of the week. These technologies are referred to as 'quasi static'. TomTom's 'IQ Routes' and Garmin's 'trafficTrends' rely on this technology [8-10]. The latest

technologies such as TomTom's 'HD Traffic' [8,9] include real time traffic data in the routing algorithm. The navigation device receives traffic nearly continuously by connecting to the databases to collect new traffic information. If a traffic situation changes rapidly, user can be informed on the fly due to fast update times (every 2 minutes). These systems apply a dynamic routing strategy.

## 4 Comparing static routes

The aim of this study is to determine to which extent the routes – calculated by existing route planners – take into account the policy-made categorization based on the principles of the RSV. For this purpose several origins and destinations were selected, on a 'preferred' route (taking into account the RSV-principles) between these location was calculated. These routes were compared to their corresponding static and dynamic routes, suggested by route planners. The Flemish road categorisation and network has a tree-like structure. To calculate a 'preferred' route, a routing process based on the RSV can be developed which follows a fixed progression of road use [11]; the route departs from the starting point on a road with a low category and moves gradually to the nearest road with a higher category until the highest categorized road for the route is reached. While approaching the endpoint, the category of the used roads gradually decreases until the destination is reached. This algorithm calculates a shortest path between two locations in a network. A 'shortest path' can be defined as a path with the lowest resistance. This can be the shortest time, shortest distance or any other value assigned to the network. To calculate a RSV route, the 'shortest path' is defined as the route with the shortest distance dependant on the used road categories and the function of the trip, e.g. travelling on international, Flemish, supra-local or local level. To do so, the distance of each road is multiplied by a weight factor. Each road category has a corresponding weight factor, and for each origin/destination relationship, different weight factors are assigned to the categories. This means that different sets of weights are used for different travel functions. Higher weights on a stretch of road will cause higher resistance on that road, so the use of this road for route planning will become less favourable. This implies that low categories should have high weights, and vice-versa.

## 5 Comparing time dependent routes

### 5.1 Method

Five well chosen origin–destination relations were selected where different navigation systems generated different routes. The applied technologies are TMC, IQ Routes, trafficTrends and HD Traffic. All tests were executed on a Thursday evening around 5 P.M.. This point in time was selected based on peak hours, and longest traffic congestion in Flanders, which generally occur on Tuesdays and Thursdays. The policy based and preferred RSV-routes are compared to the static and time–dependant routes suggested by the navigation systems.

First, while comparing static routes with time dependant routes, attention is given to the difference in the use of the road network. Will the time dependant routes use higher categorised roads, or use lower categorised roads than the original static route? If the trip uses roads of a higher level than the desired RSV route, this can be considered to be improper road use. If the trip uses roads of a lower level than desired, one may refer to this as cut-through traffic. Changes in road use by time dependent routes can be defined as a 'mesh increase' or a 'mesh reduction'. A 'mesh increase' indicates the use of higher level roads to make a trip, while a 'mesh reduction' indicates the use of lower level roads. Consequently it is possible that a mesh increase (or reduction) could provide a more favourable route which is in correspondence with policy based principles (and thus the RSV-route).

Secondly, the differences in the use of road categories between RSV-routes and both static and time–dependant routes by route planners is analysed.

## 5.2 Results

The results for the different technologies are presented briefly. First the results for the quasi static routes are presented followed by the results of dynamic routes. Each technology is analysed based on two tables. The first table represents the mesh reduction, mesh increase or absence of both and their impact on the road network. If the initial static route is defined as cut-through traffic, a mesh increase is desirable. If on the other hand the initial static route causes improper road use, a mesh decrease is desired. The second table represents the use of the road categories along a trip. The differences in road use between the static routes and the time dependent routes are rather small.

### 5.2.1 Quasi static routes

Table 1 shows that in 5 out of 20 cases the quasi-static route makes use of road categories that are preferred according to policy principles. In 3 cases a mesh reduction is performed where this is undesirable and stimulating or worsening cut-through traffic. In 8 cases, the quasi-static route is similar to the static route and makes improper use of the road network. A mesh increase is performed in 3 cases. One of these is desirable, but the other 2 cause improper road use where previously no problem occurred.

**Table 1** Change in use of road network for quasi static routes

Initial state	Total	mesh reduction	no action	mesh increase
Cut-through traffic	5	2	2	1
no problem	5	1	2	2
Improper road use	10	2	8	0
Total	20	5	12	3
quasi-static route causes preferred road use				
quasi-static route causes cut-through traffic				
quasi-static route causes improper road use				

**Table 2** Percentage of road use by category

Road use (%)	Highway	Primary I	Primary II	Secondary I	Secondary II	Secondary III	Type I	Type II	Type III
RSV	31.1	1.8	27.5	3.1	5.4	6	14.1	7.1	3.9
static	42.5	0	13.05	0.85	1.5	8.4	15.05	12.5	6.25
quasi static	45.1	0	11.3	0.9	1.85	6.2	14.9	13	6.75

The results in table 2 include all routes. However, not all quasi static route planners suggest a route that differs from the static route planners. The average use of road categories doesn't vary much (static vs quasi static). Use of highways has slightly increased (42.5% to 45.1%) and the use of local roads type III has not changed (6.25% and 6.75%). However, differences in local road usage of individual routes can vary up to 15%, so these average results should be viewed with care. If we compare the RSV-route to the (quasi-)static route, we see an increase of local road use, in particular Local roads type III (4% to 6.5%).

### 5.2.2 Dynamic routes

According to table 3, dynamic routing technologies have a positive influence on the use of the road network. For 6 out of 9 cases, problems were solved. In 5 cases there is a mesh reduction where this can be preferred. A mesh reduction implies the use of the lower road network. In Flanders however, the lower road network is not thoroughly developed (mostly because of built-up areas along important roads) so it can be argued if a mesh reduction is really desirable. On the other hand, the higher level road network is often over saturated, so a mesh reduction would relieve the highways.

**Table 3** Change in use of road network for dynamic routes

Initial state	Total	mesh reduction	no action	mesh increase
Cut-through traffic	3	0	2	1
no problem	1	0	1	0
Improper road use	5	5	0	0
Total	9	5	3	1
dynamic route causes preferred road use				
dynamic route causes cut-through traffic				
dynamic route causes improper road use				

**Table 4** Percentage of road use by category

Road use (%)	Highway	Primary I	Primary II	Secondary I	Secondary II	Secondary III	Type I	Type II	Type III
RSV	26,3	2,3	32,4	4,1	3,5	3,9	14,7	8,2	4,8
static	29,4	0,0	16,8	0,4	0,3	11,9	19,6	12,8	8,8
quasi static (only one system)	36,2	0,0	14,1	0,3	1,3	5,5	21,5	13,9	9,6
dynamic	17,2	0,0	15,0	5,0	4,2	4,6	22,9	17,9	13,0

In table 4, it is observed that the use of local roads by navigation systems is higher than the RSV-routes. This is in particular the case for local roads type III. It is also apparent that dynamic routes cause a shift from main roads to secondary and local roads (up to 13%). This can be expected since congestion often occurs on the main roads. Nevertheless, the use of local roads type III should never increase because they should only be used to give access to residences. It is however not possible to make conclusions concerning the effect of dynamic routing on cut-through traffic. Cut-through roads are scarcely or not at all covered by the technology. Congestion and incidents on these roads is unknown.

## 6 Conclusion

The aim of this study is to demonstrate to what extent the existing policy-made road categorization is implemented by navigation systems, and whether these principles may contribute to a more sustainable route navigation. Particular attention is given to the use of local roads by through-traffic. A comparison of routes generated by navigation systems to 'preferred' RSV-routes illustrates a difference in road use and highlights the possible excessive use of local roads by through-traffic due to the use of navigation systems. The findings of this study show that the static routes calculated according to the RSV principles make less use of local roads than routes proposed by navigation systems. By applying RSV routes, the use of local



roads Type III can be reduced and it can limit the use of this low level roads during the trip and may contribute to a higher livability of residential areas. The navigation industry provides the user of a wide range of travel support options to calculate time dependent routes. All these technologies aim to reduce the travel time in case of traffic congestion. The influence of the technology on the road network and the traffic liveability is highly dependent on the network coverage. Although this technology might have the potential to fully make use of the entire road network by spreading traffic according, dynamic technologies do not cover the entire road network. The absence of a full coverage has a negative impact on road usage of the calculated dynamic routes. Therefore, traffic is often redirect to secondary and local roads. For the calculation of RSV routes in this study, the existing policy-made road categorization is used. New interpretations of the road categorization in Flanders are possible, with enhanced attention to road safety, multimodal use, multiple functions of highways in urban areas, etc... This may influence the 'preferred' route due to addition of other features and parameters to the routing algorithm. A routing based on road classification is static. If an incident or congestion occurs along a 'preferred' route, an alternative route will be sought on the local road network. But can a routing method, based on the principles of the RSV, make the adjacent road network available? The study 'Cut-through traffic in the South-East of Antwerp [12] shows that RSV road categorization is unable to form a solid basis to deal with traffic in congested networks. Thus time dependent routing may spread traffic in a beneficial manner, but it is currently unknown whether the road network is capable of supporting this technology, and more generally, supporting alternative routes in the road network.

## References

- [1] Cohn N. Real-Time Traffic Information and Navigation An Operational System. *TRANSPORTATION RESEARCH RECORD*. 2009;(2129):129-35.
- [2] Afdeling Ruimtelijke Planning. Ruimtelijk Structuurplan Vlaanderen. 2004.
- [3] Lauwers D, Gillis D. Towards new principles of road categorization - reflections based on practices in Belgium and Eastern Europe. In: First International Conference on Road and Rail Infrastructure (CETRA 2010)2. Opatija, Croatia: 2010.
- [4] Lauwers D. Bedenkingen na 10 jaar wegencategorisering. *Verkeersspecialist*. 2008;149:20-4.
- [5] Bradt F. Synthese van de wegencategorisering in Vlaanderen, afgestemd op verschillende planningniveaus. (unpublished work). 2008;
- [6] Lauwers D. Functional road categorization : new concepts and challenges related to traffic safety, traffic management and urban design : reflections based on practices in Belgium confronted with some Eastern European cases. In: Rosca E, editor. *Transportation and land use interaction, Proceedings*. POLITECHNICA Press; 2008. p. 149-64.
- [7] NAVIGATIEHOSTING. Navigatiehosting TMC [Internet]. [cited 2011 May 23]; Available from: <http://www.navigatiehosting.nl/inidex.php>
- [8] Schäfer R-P. IQ routes and HD traffic: technology insights about tomtom's time-dynamic navigation concept [Internet]. In: *Proceedings of the the 7th joint meeting of the European software engineering conference and the ACM SIGSOFT symposium on The foundations of software engineering*. New York, NY, USA: ACM; 2009. p. 171-2. Available from: <http://doi.acm.org/10.1145/1595696.1595698>
- [9] TomTom International B.V. TomTom online [Internet]. [cited 2011 Apr 26]; Available from: <http://www.tomtom.com>
- [10] NAVIGON. NAVIGON and the world is yours.
- [11] Dijkstra A. Veilig samenspel van wegenstructuur, verkeerscirculatie en routekeuze. 2010.
- [12] Keppens M, Lauwers D, Rottiers K, Dotremont R. Sluipverkeer in de Zuidostrand van Antwerpen : Eindrapport versie 4.0a. Antwerpen: 2007.

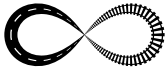

## BEHAVIORAL ANALYSIS OF DEPARTURE TIME DECISION CONSIDERING REDUNDANCY OF RAILROAD NETWORK

Kazuyuki Takada<sup>1</sup>, Makoto Fujii<sup>2</sup>, Shigeki Sugiyama<sup>1</sup>

<sup>1</sup> Tokyo Denki University, Japan

<sup>2</sup> The University of Tokyo, Japan

### Abstract

Reliability of travel time is one of the important factors affecting mode choice and route choice behaviors. Recently, many studies have investigated variability of travel time and engaged in developing methodology to evaluate economic value of the travel time reliability. We have investigated the travel time reliability of the railroad from the point of departure time decision of railroad users. As the results of our previous studies, it becomes clear that railroad user prepares buffer time to deal with the delay of railroad. Furthermore, it indicates that the buffer time is influenced by several factors such as travel distance, usages frequency of railroad, and number of times of transfer. Meanwhile, reliability as a function of transport network was not considered in the previous studies. Therefore, this study aims to develop a methodology to evaluate the travel time reliability with considering the level of redundancy of the railroad network. The data collected by internet survey was utilized to estimate a departure time decision model which can describes the length of buffer time.

*Keywords: railway, redundancy, departure time decision*

### 1 Introduction

Reliability of travel time is one of the important factors affecting mode choice and route choice behaviour. Recently, many studies have investigated variability of travel time and engaged in developing methodology to evaluate economic value of the travel time reliability. Most of them have focused on the reliability of road traffic. Meanwhile, research on the travel time reliability of railroad and air transport which operates based on the planned timetable has not sufficiently advanced so far.

We have investigated the travel time reliability of the railroad from the point of departure time decision of railroad users [1],[2]. As the results of our previous studies, it becomes clear that railroad user prepares buffer time to deal with the delay of railroad. Furthermore, it indicates that the buffer time is influenced by several factors such as travel distance, usages frequency of railroad, and number of times of transfer.

Meanwhile, reliability as a function of transport network was not considered in the previous studies. However, robustness of railroad network should be considered when user benefit by improving travel time reliability is evaluated. Therefore, this study aims to develop a methodology to evaluate the travel time reliability with considering the level of redundancy of the railroad network.

At first, some indices which represent the level of redundancy of railway network were developed. Then, these indices for each railway passengers who were respondent of the questionnaire survey were calculated. Secondly, the information included in these indices was consolidated by factor analysis. As the result of the analysis, four kinds of factors were extracted. Thirdly, the

departure time decision of railway commuter was analyzed. In this study, Fosgerau's approach was applied to build the decision model [3],[4]. Regression model regarding buffer time estimated. Four indices which represent each factor extracted by the factor analysis were considered as explanatory variables of the model. It is demonstrated that the level of redundancy influences on buffer time of railway commuters.

## **2 Data**

This study focused on the influence of railway network redundancy on the departure time decision of railway commuters. Therefore, the data regarding travel behaviour of railway commuters was collected by conducting internet survey. Detail of the data was described in [1].

## **3 Indices of railway network redundancy**

### **3.1 Development of railway network redundancy**

To evaluate the level of the redundancy, we developed indices as described below.

#### **3.1.1 Index.1**

Index.1 is defined as number of available routes between origin and destination. This index presents the robustness of redundancy. The larger value of index.1 indicates the higher redundancy, because number of available routes increase. The maximum of the index is set to 10.

#### **3.1.2 Index.2**

Index.2 is defined as travel time difference between first best and second best routes. This index presents effectiveness of the second best routes. The smaller value of index.2 indicates the higher redundancy, because the additional time is not large in case the value is small.

#### **3.1.3 Index.3**

Index.3 is defined as travel time difference between first best and third best routes. This index presents effectiveness of the third best routes. The smaller value of index.3 indicates the higher redundancy, because the additional time is not large in case the value is small.

#### **3.1.4 Index.4**

Index.4 is defined as number of routes of which increase ratio of travel time is less than certain percentage. Index.4-1, 4-2, 4-3 and 4-4 are assessed by number of routes of which increase ratio of travel time against the best route is less than 10%, 20%, 50% and 100% respectively. The larger value of index-4 indicates the higher redundancy, because number of available routes increase.

#### **3.1.5 Index.5**

Index.5 is defined as minimum number of available routes of each boarding section. This index presents the section level redundancy. The larger value of index.5 indicates the higher redundancy, because the redundant level of most vulnerable section is increase.

#### **3.1.6 Index.6**

Index.6 is defined as the largest travel time difference between first best and second best routes among boarding sections. This index presents the section level redundancy. The larger value of index.6 indicates the higher redundancy, because the redundant level of most vulnerable section is increase. Index.6-1 and 6-2 are assessed by the largest travel time difference between first and second best routes among each section and also first and third best routes among each section.

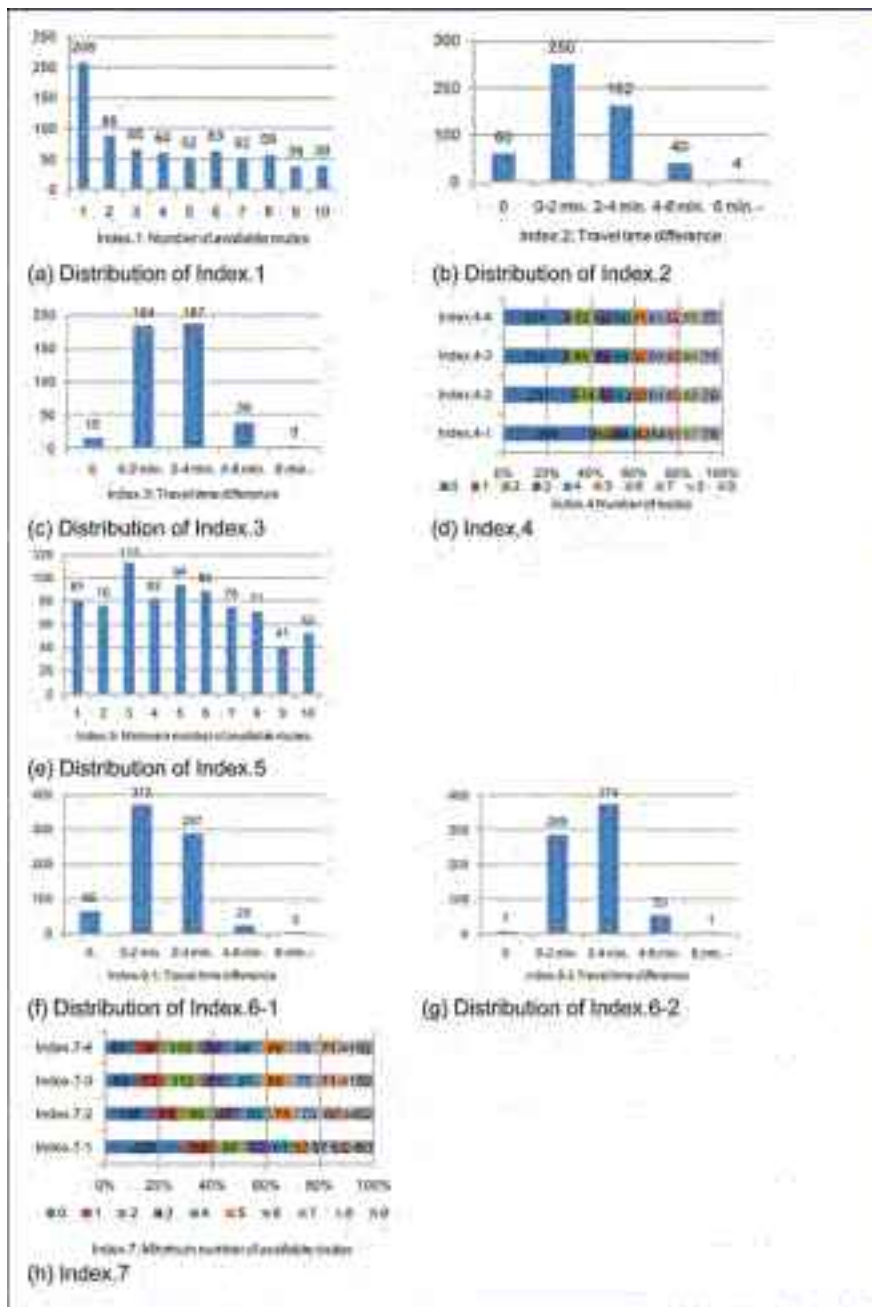

Figure 1 Calculation results of the indices

### 3.1.7 Index.7

Index.7 is defined as minimum number of available routes among boarding sections of which increase ratio of travel time against best route is less than certain percentage. This index presents the section level redundancy. The larger value of index.7 indicates the higher redundancy, because the redundant level of most vulnerable section is increase. Index.7-1, 7-2, 7-3 and 7-4 are assessed by the minimum number among boarding sections of which increase ratio of travel time against the best route is less than 10%, 20%, 50% and 100% respectively.

The indices developed in former section were calculated for the respondent of the survey. The results are shown in figure 1.

## 4 Factor analysis of redundancy of railroad network

Factor analysis is applied to consolidate the information which is comprised in the developed indices. The result of factor analysis is shown in Table 1. The value in each cell is factor loading of correspondent variable. As shown in the table, four factors were extracted. Meaning of each factor is explained according to the largeness of the factor loadings. First factor represents robustness of redundancy between O-D. Second factor represents Robustness of redundancy in boarding sections. Third factor represents the Effectiveness of alternative routes between O-D. Fourth factor represents Effectiveness of alternative routes in boarding sections. One variable represents each factor was considered as explanatory variables of departure time decision model in next chapter. Index.2, 4-3, 5 and 6-2 with the largest factor loading of each factor were selected as the variables.

**Table 1** Result of factor analysis

Variable	Factor-1	Factor-2	Factor-3	Factor-4
	Robustness of redundancy between O-D	Robustness of redundancy in boarding sections	Effectiveness of alternative routes between O-D	Effectiveness of alternative routes in boarding sections
Index.1	0.981	-0.022	-0.136	-0.004
Index.2	-0.321	-0.019	0.820	-0.008
Index.3	-0.457	-0.022	0.773	-0.039
Index.4-1	0.821	-0.027	-0.429	-0.038
Index.4-2	0.936	-0.008	-0.283	-0.008
Index.4-3	0.987	-0.029	-0.145	-0.010
Index.4-4	0.983	-0.032	-0.148	-0.015
Index.5	-0.037	0.984	-0.015	-0.137
Index.6-1	-0.006	-0.368	-0.021	0.750
Index.6-2	-0.042	-0.351	-0.013	0.757
Index.7-1	-0.008	0.797	0.005	-0.405
Index.7-2	-0.013	0.918	-0.001	-0.294
Index.7-3	-0.022	0.975	-0.018	-0.171
Index.7-4	-0.037	0.984	-0.014	-0.139
Eigen-value	5.5	5.2	1.00	0.75
Variance explained	34.07%	33.06%	11.41%	10.41%

## 5 Departure time decision considering

### 5.1 5.1 Description of departure time decision

In this study, Fosgerau's methodology was applied to formulate departure time decision problem [3],[4]. A cost function depending on departure time  $D$  is written in eqn. (1).

$$U(D, T) = \alpha D + \omega T + \beta(T - D)^+ \quad (1)$$

$\alpha, \beta, \omega$  is unknown parameters. The first term is the cost of starting early which is opportunity cost of interrupting a prior activity. The second term is the cost of travel time  $\tau$ . And, the third term is the cost of being late where  $(T - D)^+$  is schedule delay late.

Meanwhile, travel time  $\tau$  is composed by two terms as seen in eqn.(2).

$$T = \mu + \tau_L \quad (2)$$

First term is a minimum travel time based on timetable and second term is recognized delay time. The recognized delay time is set by each commuter considering the occurrence of operation delay. Meanwhile,  $\tau_L$  is a random variable whose probability density function is  $f(\tau_L)$  and distribution function  $F(\tau_L)$ . In this study, the distribution of recognized delay time is assumed to be exponential distribution.

The problem of departure time decision is express by eqn. (3) which is disutility minimum problem.

$$E(U(D)) = \min \left[ \alpha D + \omega \mu + \beta \int_{D - \mu}^{\infty} (\mu + \tau_L - D) f(\tau_L) d\tau_L \right] \quad (3)$$

The optimal departure time  $D^*$  is derived by solving eqn. (3).

$$D^* = \mu + F^{-1}(1 - \frac{\alpha}{\beta}) \quad (4)$$

Moreover, it is thought that the distribution of the recognized delay time  $\tau_L$  is differ by commuter. Therefore, exponential distribution with covariates  $x_i$  is utilized to express the difference of distribution. Then, the probability density function of the recognized delay time is as shown in eqn. (5).

$$f(\tau_s) = \lambda \exp(\sum_i \theta_i X_i) \cdot \exp \left\{ (-\lambda \tau_s) \exp(\sum_i \theta_i X_i) \right\} \quad (5)$$

Therefore, the optimal departure time in eqn. (4) is rewritten in eqn. (6).

$$D^* = \mu - \frac{\ln \left\{ -(1 - \frac{\alpha}{\beta}) + 1 \right\}}{\lambda \cdot \exp \sum_i \theta_i X_i} \quad (6)$$

In this study, regression analysis regarding the buffer time is executed. The buffer time is calculated by eqn. (7).

$$D^* - \mu = - \frac{\ln \left\{ -(1 - \frac{\alpha}{\beta}) + 1 \right\}}{\lambda \cdot \exp \sum_i \theta_i X_i} \quad (7)$$

## 5.2 Estimation Result

Two kinds of model are estimated. Travel distance and number of transfers are considered as covariates (explanatory variables) in Model 1. Meanwhile, In model 2 consider the railway network redundancy indices as covariates beside the explanatory variables in model 1.

Hierarchical Bayesian method is applied and Markov Chain Monte Carlo simulation is utilized to estimates the parameters in each model. Prior distribution of each parameter is shown in Table 2. Estimation result is shown in Table 3.

Plus sign of the estimates indicates that the buffer time increases in accordance with the increase of the value of correspondent variable. For example, the longer travel distance become, the longer the buffer time become. Sign's condition of all variables is reasonable.

Estimates of travel distance and number of transfers, index.2 and index.4 are statistically significant with 95% confidence. Meanwhile, the estimates of index.5 and index.6-2 are statistically significant with 90% confidence. As the results, it indicates that the redundancy is the factor affecting the buffer time of railway commuters.

**Table 2** Prior distribution

	Distribution form	Prior distribution
$\alpha$	Uniform distribution	$\alpha \sim U[0,2]$
$\beta$	Normal distribution	$\beta \sim U[0,2]$
$\lambda$	Uniform distribution	$\lambda \sim U[0,2]$
$\theta$	Log-normal distribution	$\theta \sim LN(0,10)$

**Table 3** Result of parameter estimation

	Explanatory variables	Model1		Model2	
		Estimates	t value	Estimates	t value
$\alpha$	Head start	0.416	1.25	0.208	1.28
$\beta$	schedule delay late	1.385	3.33	1.255	2.63
$\lambda$	Scale parameter	0.409	1.40	0.518	1.76
$\theta_1$	Logarithm of traveling distance(km)	-0.133	-2.29	-0.150	-2.17
$\theta_2$	Number of transfers(times/trip)	-0.195	-3.82	-0.233	-4.02
$\theta_3$	Index.2			-0.055	-1.96
$\theta_4$	Index.4-3			0.048	2.40
$\theta_5$	Index.5			0.016	1.60
$\theta_6$	Index.6-2			-0.041	-1.71
DIC:DevianceInformation Criterion		3045.7		3082.6	
Number of samples		424			

## 6 Conclusion

In this study, we developed some indices to assess the level of railway network redundancy. Through the factor analysis, four evaluation factors were extracted. The departure time decision model is formulated and solved considering the variables regarding network redundancy. As the result of parameter estimation, redundancy of railway network is affecting departure time decision of railway commuters.

## Reference

- [1] Takada, K., Fujiu, M. & Yokoyama, S.: Perception of the Travel Time Reliability of the Urban Railway Service in Tokyo, Proceedings of the First Conference on Road and Rail Infrastructures- CETRA 2010, pp.873-879, 2010.
- [2] Takada, K., Fujiu, M., Yokoyama, S. & Suzuki T.: Departure Time Decision of Railway Users under Travel Time Uncertainty, Proceedings of the Eastern Asia Society for Transportation Studies, Vol.8, , pp.209-219, 2011.
- [3] Fosgerau, M.: What is the value of reliability?: International Meeting Transportation Research Board and the Joint Transport Research Centre, 2009.
- [4] Fosgerau, M. & Karlstrom, A.: The value of reliability: Transportation Research Part B, Vol.44, No.1, 33-49, 2010.





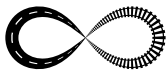

## TRUCK TRIP GENERATION RATES FOR DIFFERENT TYPES OF FACILITIES IN POLAND

**Tomasz Kulpa**

*Politechnika Krakowska, Poland*

### Abstract

Measurements to estimate truck trip generation of particular facilities, such as warehouses, factories and logistics centres are rarely conducted in Poland. Those measurements are quite easy to conduct by counting vehicles entering and leaving a particular facility. Results of these studies might be used as the first step in a 4-stage model. Obtaining trip generation rates per 1 employee or 1000 sq m of company area would be useful for aggregation of trip generation from single generators to a given traffic zone. Moreover, the results would give information about daily variability in time (e.g. the peak hour). This paper presents research conducted in Krakow. The obtained trip generation rates are provided and compared with trip generation rates from other studies. Additionally, advantages and disadvantages of single generators measurement are discussed.

*Keywords: trip generation, trip modelling, freight transport,  
4-stage model, traffic measurements*

### 1 Introduction

Freight traffic is very often generated by particular facilities, like manufacturing plants, warehouses, distribution centres or intermodal facilities. Those might be called single traffic generators as they are characterized by high accumulation of freight trips origins and destinations in one place. Although estimation of trip generation of different freight generators seems to be crucial to trip modelling, there were only a few studies conducted in Poland ([4], [11]). Nevertheless, the results of the research done so far provide interesting information, some of which will be reported in this paper. While reviewing trip generation studies, it is easy to notice that the majority of them were done in the United States of America. Trip generation studies were conducted for different types of facilities (e.g. [1], [2], [8]). Results of many different studies were gathered in Quick Response Freight Manual I/II ([5], [6]) as well as in NCHRP Reports ([9], [10]). Trip generation studies for particular cities were conducted as well ([7]). Since this paper deals exclusively with the situation in Poland, only Polish studies will be reviewed.

#### 1.1 Review of Polish studies

Zipser T. et al [11] present the results of 24-hour measurements done at two shopping centres placed in the city of Wrocław. Trip generation rates, given in Table 1, were calculated per 1000 m<sup>2</sup> of shopping centres usable area. Abbreviations used in Table 1, as well as throughout the whole text, are as follows: SD – delivery trucks, SC – single unit trucks, SCP – articulated trucks (a truck with a trailer or a tractor with a semitrailer).

**Table 1** Trip generation rates for shopping centres in Wrocław [11].

Facility	Usable area in 1000 m <sup>2</sup>	Trip generation rates per 1000 m <sup>2</sup> of the usable area [trips/day/1000 m <sup>2</sup> ]		
		SD	SC	SCP
1	36.7	2.23	1.63	0.33
2	58.0	3.14	1.69	0.76

In [4], the author analysed deliveries to one large-space building material store in Krakow for two months. This analysis was conducted under the supervision of the author of this paper. The data about the inbound and outbound traffic was given provided by the store operator. On the basis of the available data all trucks were classified as light (gross vehicle weight below 3.5 t) or heavy (gross vehicle weight above 3.5 t) trucks. It was proved that the number of deliveries on Mondays, Wednesday and Fridays are statistically significantly different from the number of deliveries on Tuesdays and Thursdays. The relevant trip generation rates are provided in Table 2.

**Table 2** Trip generation rates for large-space building material store in Krakow [4].

Days of week	Trip generation rates per 1000 m <sup>2</sup> of the building area [trips/day/1000 m <sup>2</sup> ]		
	All trucks	Light trucks	Heavy trucks
Mon, Wed, Fri	2.78	1.18	1.60
Tue, Thu	3.22	1.28	1.94

## 2 Trip generation for different facilities in Krakow

This part of the paper presents the results of the author's own research. The trip generation model was developed for different types of facilities as well as for different types of vehicles. Traffic measurements results were used for developing the model.

### 2.1 Data collection

The measurements were conducted in the year 2011. Different types of facilities were taken into account. For the majority of them measurements lasted from 6:00 to 18:00, which in most cases coincided with the facilities opening hours. For two logistic centres and manufacturing plant 24-hour measurements were conducted. Depending on facility registered number of trips varied from 31 to 344.

During the measurements, the number of freight vehicles that entered or left the analysed facility was recorded. For each vehicle entry and exit time, the registration number (if possible) and vehicle type were recorded. Freight vehicles were divided into 3 groups: SD – delivery trucks, SC – single unit trucks, SCP – articulated trucks (a truck with a trailer or a tractor with a semitrailer).

**Table 3** Average trip generation rates for different types of facilities in Krakow [trips/12 hours].

Objects group	Trip generation rates per unit [trips/12 hours]						
	Unit	Production			Attraction		
		SD	SC	SCP	SD	SC	SCP
Concrete–mixing plant	1 are of site area	0.011	0.074	0.207	0.011	0.081	0.196
Office	1000 m <sup>2</sup> of office area	0.005	0.000	0.000	0.003	0.000	0.000
Large space shopping centre	1000 m <sup>2</sup> of usable area	1.145	0.314	0.225	0.853	0.269	0.205
Logistic centre	1000 m <sup>2</sup> of building area	3.721	2.381	2.348	3.501	3.227	2.055
Wholesale	1000 m <sup>2</sup> of building area	2.957	8.279	3.548	4.140	8.279	2.957
Warehouse	1000 m <sup>2</sup> of building area	0.395	0.000	0.099	0.444	0.000	0.049
Manufacturing plant	1000 m <sup>2</sup> of building area	2.007	0.973	0.519	2.506	1.346	0.561
Large space building materials store	1000 m <sup>2</sup> of building area	1.826	0.925	0.336	1.826	0.925	0.224
Building materials yard	1 are of site area	0.645	0.154	0.031	0.673	0.174	0.054
Waste sorting plant	1 are of site area	0.033	0.543	0.033	0.054	0.435	0.011
Truck service	1 are of site area	0.076	0.023	0.121	0.061	0.038	0.091

## 2.2 Review of the obtained results

### 2.2.1 Trip generation

The facilities were divided into different groups on the basis of the collected data. Trip generation rates (productions and attractions) were calculated for each group. The results are shown in Table 3. The sample sizes varied from 1 to 8 due to the scope of measurements which was to cover different types of facilities.

The results given in Table 3 confirm the obvious fact that truck trip generation is highly dependent on the facility type. Moreover, the production and attraction rates for a particular facility may differ. In some cases the reason is the measurement time (some trips were not registered), in others it is the facility type (e.g. logistic centres, manufacturing plants). On the other hand, for the concrete–mixing plant, large–space building materials stores or building material yards, production and attraction rates are equal. The obtained truck trip generation rates for the large–space building materials stores (the average trip generation rate for production and attraction equals 3 [trips/1000m<sup>2</sup>/day]) are the same as the results of [4] (average trip generation rate for all days equals 3 [trips/1000m<sup>2</sup>/day])

**Table 4** Comparison of trip generation and trip generation rates for two logistic centres in Krakow [trips/day].

Logistic centre	Trip generation (A) Trip generation rates per 1000 m <sup>2</sup> building area (B) Trip generation rates per 1 are of site area (C)	Production			Attraction		
		SD	SC	SCP	SD	SC	SCP
		LC 1	A	19	34	33	34
	B	1.056	1.889	1.833	1.889	2.5	2.333
	C	0.049	0.088	0.085	0.088	0.116	0.108
LC 2	A	17	31	30	10	18	27
	B	1.545	2.818	2.727	0.909	1.636	2.455
	C	0.049	0.089	0.086	0.029	0.051	0.077

For two logistic centres 24-hour measurements were conducted. The results are presented in Table 4. Trip generation (row A) and trip generation rates (rows B and C) are given for three types of freight vehicles. Although productions for both logistic centres are almost equal, trip generation rates are significantly different, which is the result of a different building area. A big difference in trip generation rates might also be observed for attractions. Differences in trip generations result from various characteristics of the logistic centres (in LC1 the warehouse space is rented by various companies while LC2 is used by only one company trading in household appliances).

### 2.2.2 Variability in time

For both logistic centres (LC1 and LC2) variability of inbound and outbound traffic during day was identified. The facilities operate 24 hours a day, and the analysis of variability covered the time from 6:00 to 6:00 the next day.

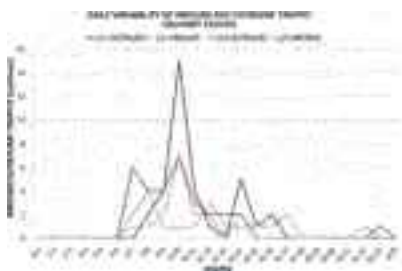

**Figure 1** Inbound and outbound traffic daily variability in time – delivery trucks.

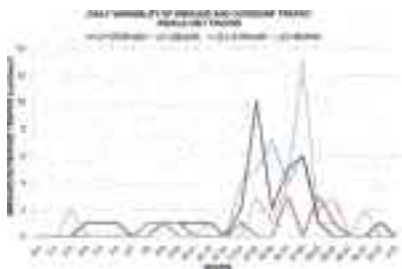

**Figure 2** Inbound and outbound traffic daily variability in time – single unit trucks.

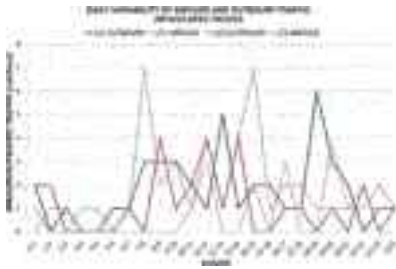

**Figure 3** Inboard and outbound traffic daily variability in time – articulated trucks.

On presented figures high variability of inbound and outbound traffic might be seen. For delivery trucks peak hours might be determined between 8:00 and 10:00 (Fig. 1) while for single unit trucks between 14:00 and 18:00 (Fig. 3). For articulated trucks peak hours can be hardly specified (Fig. 3). Share of night traffic (from 18:00 to 6:00) for analysed logistic centres varies from 0 to 5 % for delivery trucks, from 15 to 40 % for single unit trucks, and from 22 to 50 % for articulated trucks.

A different time period was used to identify the variability in time in the case of the other logistic centre. Measurements were conducted on Thursdays for two subsequent weeks and covered the facility's whole opening time. The results presented in Table 5 show that even for the same day of the week trip generations for the same facility might be significantly different.

**Table 5** Comparison of trip generation rates for one logistic centre on two days, measurement period 6:00 – 18:00 [trips/12 hours].

No	Date	Trip generation Trip generation rates per 1000 m <sup>2</sup> of the building area					
		Production			Attraction		
		SD	SC	SCP	SD	SC	SCP
1	20-11-2011	23	11	8	31	15	9
		5.141	2.459	1.788	6.929	3.353	2.012
2	27-11-2011	18	5	13	23	11	14
		4.023	1.118	2.906	5.141	2.459	3.129

### 2.3 Model development

On the basis of the sample sizes, a trip generation model was developed for logistic centres and manufacturing plants. The linear regression model was used, as shown in Eq. (1):

$$TG = a \cdot X \quad (1)$$

where: TG – trip generation (production or attraction) [trips/12 hours], a – model parameter, x – building area of the facility in 1000 m<sup>2</sup>.

Due to the limited number of available explanatory variables, only the area of the building was used. The analysed objects were single-storey so the area of the buildings is almost equal to the usable area. Moreover, the model was developed for 12-hour period since such was the length of the measurement time. Model parameters for logistic centres are presented in Table 6 while for manufacturing plants in Table 7.

The obtained results show that only the trip generation model for delivery trucks for logistic centres and for single unit trucks for manufacturing plants has the satisfactory coefficient of determination. In other cases R<sup>2</sup> values are too low for the model to be acceptable.

**Table 6** Trip generation model parameters for logistic centres.

Vehicle type	Production		Attraction	
	a	R <sup>2</sup>	a	R <sup>2</sup>
SD	2.96	0.93	2.95	0.93
SC	2.03	0.73	2.22	0.64
SCP	1.52	0.75	1.38	0.80

**Table 7** Trip generation model parameters for manufacturing plants.

Vehicle type	Production		Attraction	
	a	R <sup>2</sup>	a	R <sup>2</sup>
SD	0.64	0.40	0.54	0.41
SC	0.33	0.93	0.32	0.83
SCP	0.34	0.67	0.45	0.68

### 3 Summary and conclusions

The reviewed Polish studies as well as the presented author's own research should be considered pilot studies. The scope and time period of the measurements permit showing only a fraction of the truck trip generation by different single freight generators. The aim of the author's research was to identify different types of facilities and the appropriate methodology. Nevertheless, the results it has brought are very interesting and may constitute a starting point for further research.

One of the problems that occurred during conducting the study was getting permission from facilities operators to do the measurements. None of the operators the author had approached agreed to provide data about inbound and outbound freight (except [4]). It was also impossible to get the information from the truck drivers. Because of these obstacles there is no information about the start (for inbound traffic) or end (for outbound traffic) of the freight trips. In further research, some support from the relevant authorities will need to be secured, which may encourage operators to cooperate.

One day measurement is too short and may give unreliable results. Measurements that cover a longer period (e.g. a week, a month) or several measurements during one year may give more accurate results. It may enlarge the sample size as well as enable the weekly, monthly or yearly variability of freight trip generation. The results presented in this paper proved that freight traffic is highly variable in time. Although it may seem a trivial conclusion, yet it confirms the results of other freight studies.

The developed model needs to be improved in further studies. It should cover a 24-hour time period and take more types of facilities and more sites into account. For manufacturing plants, the division into different lines of trade should be introduced. Nevertheless, the developed model may be used for making rough estimations of trip generation at planned logistic centres, manufacturing facilities or stores. Assuming the average share of night traffic, its daily trip generation may be estimated, as shown in Table 8.

**Table 8** Proposed trip generation rates for three types of facilities [trips/day].

Facility	Trip generation (production or attraction) rates per 1000 m <sup>2</sup> of the building area [trips/day]		
	SD	SC	SCP
Logistic centre	3.02	2.80	2.32
Manufacturing plant	0.63	0.36	0.63
Large space building materials store	3.00		

## References

- [1] Al-Deek, H. M., Johnson, G., Mohamed & A., El-Maghraby, A.: Truck trip generation model for seaports with container/trailer operations, *Transportation Research Record: Journal of the Transportation Research Board*, 1719, pp. 1-6, 2000.
- [2] Holguin-Veras, J., Lopez-Genao, Y. & Salam, A.: Truck Trip Generation at Container Terminals: Results from a Nationwide Survey, *Transportation Research Record No. 1790, Freight Transportation*, pp. 89-96, 2002
- [3] Iding, Mirjam H.E., Meester, Wilhelm J., Tavasszy & Lóri A.: Freight trip generation by firms, Paper for the 42nd European Congress of the Regional Science Association, Dortmund, 2002.
- [4] Kędroń, K.: Analysis of truck trip generation at large-space building materials stores in Krakow, Master Thesis, Politechnika Krakowska, 2010, Supervisor: Andrzej Szarata PhD, in Polish.
- [5] Quick Response Freight Manual, Final Report, Federal Highway Administration, Washington D.C., September 1996.
- [6] Quick Response Freight Manual II, Final Report, Federal Highway Administration, Washington D.C., September 2007.
- [7] Trip Generation Manual, San Diego Municipal Code, Land Development Code, 2003.
- [8] Tolliver, D., Dybing, A., Subhro, M.: Trip Generation Rates for Large Elevators: A North Dakota Case Study, Final Report, December 2006.
- [9] Trip Generation, 8th ed., Washington, D.C., USA: Institute of Transportation Engineers, 2008.
- [10] Truck Trip Generation Data, A Synthesis of Highway Practice, NCHRP Synthesis 298, Transportation Research Board, National Academy Press, Washington, D.C., 2001.
- [11] Zipser T. et al.: Analysis of freight transport in city of Wrocław, Wrocław, 2000, in Polish.





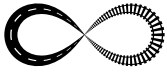

## CAPACITY VS. RELIABILITY IN RAILWAYS: A STOCHASTIC MICRO–SIMULATION APPROACH

Giovanni Longo, Giorgio Medeossi

*University of Trieste, Dept. of Civil Engineering and Architecture, Italy*

### Abstract

Railway transport is increasing its strategic role at urban, national and international level both for passenger and freight mobility. In fact, road traffic congestion causes decreasing levels of service and railways can become more and more reliable thanks to recent investments in infrastructures and technology. In recent years, the unexpected economic crisis is forcing planners to find less expensive and easier to build measures, which effectiveness has to be demonstrated before being approved.

As a result, quantitative methods have to be used, which allow a precise capacity estimation, also considering different timetable scenarios, interlocking systems and infrastructure layouts. Moreover, since a high traffic reliability level has to be offered, the effects of increasing traffic on punctuality have to be taken into consideration while estimating capacity.

In this paper a methodology is presented, one which allows a precise estimation of the trade-off between capacity and reliability on railway networks and identifies the system bottlenecks. This methodology is based on stochastic micro-simulation of rail traffic, which has been calibrated using extensive real life data. The successful results obtained using the methodology in important sections of two Pan-European corridors are described and discussed in the second part of the paper. The first case study deals with the network between Trieste and Venice, on the Corridors N.5 and 23; it plays a crucial role at a continental level, since it represents the connection between Italy and all countries of Central and Eastern Europe. The second application focuses on the Croatian part of the x Corridor (Dobova–Zagreb–Tovarnik), which connects Germany and Austria with the Balkan Area.

*Keywords: Railway capacity, timetable reliability, stochastic simulation*

### 1 Introduction

An efficient train operation is a primary success factor for all infrastructure managers, since it allows operating a higher number of trains without significant infrastructure investments. As is known, a trade-off exists between capacity and punctuality, forcing planners to find an equilibrium allowing the highest number of slots to be operated with satisfying punctuality indicators. This is particularly challenging in nodes, where the combination of different stochastic parameters on various lines and for different trains dramatically increases modelling tasks. In the last years, railway simulators have become a very powerful instrument in support of different steps of the planning process: from the layout design to capacity investigations and offer model validations. More recently, the possibility of an automatic import of infrastructure layouts and timetables widened the application spectrum of micro-simulators to large nodes and to more detailed stochastic stability evaluations.

Stochastic micro-simulators can reproduce most processes involved in rail traffic and comprehend not only its deterministic aspects, but also human factors. This is particularly rele-

vant in order to simulate traffic under realistic conditions, considering variability at border, various driving styles and stop times.

In this paper an approach is presented, in which stochastic micro-simulation is used to represent the relationship between robustness, capacity and a number of other important factors, such as traffic variability or running time supplements. The approach can be used to estimate the buffer times, and the running time supplements to obtain a given reliability level. Since the usable capacity is proportional to the buffer times, the approach leads to a very accurate estimation of the number of trains that could be scheduled on a network to obtain given punctuality levels.

## 2 Methodology

The calibrated model can be used to represent relationship between robustness and capacity, considering running time supplements and buffer times. Such evaluation can be made in some steps.

First, the micro-simulation model should be calibrated and validated by using real life data. Then, a dense timetable is constructed, which is realistic in the train mix and services, but where no buffer time between trains and no running time supplements exist. In this case, every delay leads to a propagation, which ends only when a gap due to different speed or services can be found in the timetable. A regular-interval timetable is obtained repeating the period for a given number of times.

After that, various timetables can be created adding buffer times and/or running time supplements either distributed or concentrated. Buffer times are added by simply increasing the headway and the resulting cycle time. If train performance rates are increased to their realistic levels, distributed running time supplements are automatically created. Concentrated supplements at final station can be added directly in the timetable.

To test the timetable under different conditions, process time variability functions have to be inserted. Train performance variability can be realistically considered as nearly fixed; therefore, the same parameter set of model calibration can be used. Significantly different driving styles can be supposed only in presence of new driving support systems or other measures, whose effects have to be estimated or inserted in a model.

Stop time variability is defined as a normal function, which increases a minimum stop time. The relationship between the delay and stop time has not yet been evaluated, and therefore is not inserted in the simulation. The definition of initial delay distributions for increasing delay scenarios represents another not well solved question, since no literature can be found, where the correlation between delay and the distribution function has been studied. Moreover, different fit results have been obtained, depending on the country and the case study. The block diagram of the approach is presented in Figure 1.

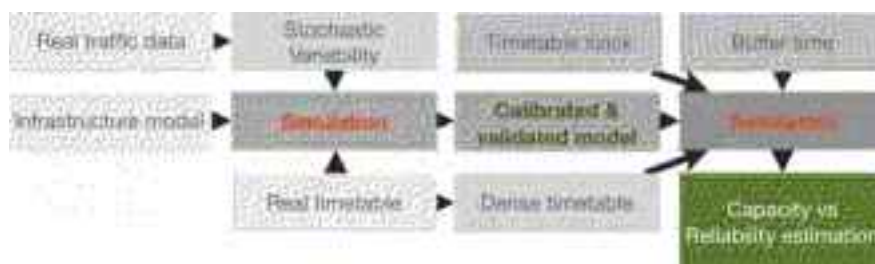

Figure 1 Block diagram of the approach

### 3 Case Study: Trieste Venice

The methodology has been tested and validated on the railway network between Trieste and Venice. The Trieste–Venice line is part of the European Corridor N. 5 and connects Slovenia to the most important economic regions in Italy, the ports of Trieste and Venice and the hump yard in Cervignano. Some branch lines are mostly used for regional traffic, while the links with Udine allow a fast connection to Austria for both long distance passenger and freight trains. The line between Trieste and Venice is about 130 km long, with a maximum speed of 150 km/h except for some critical points and different interlocking and safety systems. As a result very inhomogeneous block sections are provided, from about 1.3 to more than 5 kilometres. Moreover, the line is used by regional, Intercity and freight services, with different maximum speed, stops, priority and delay variability while entering the considered network. The model has been tested and validated comparing the real and simulated reliability indicators (punctuality and mean delay) for each train family and line section. The results of the performed simulations allow a precise representation of the infrastructure usage for each section, and the traffic robustness considering each train category, pointing out bottlenecks or other critical points.

#### 3.1 Results

The described methodology has been applied to the considered network, leading to a series of results.

First some more general results are described, which are then applied to the case study to obtain more useful capacity estimations. Capacity is inversely proportional to buffer times between slots, since these linearly increase headway times. But, increasing buffer times reduces delay propagation very significantly if compared to dense timetables and then marginally decreasing. As a result, by choosing very large buffer times, the robustness increase is less than proportional to the subsequent capacity decrease. The trade-off between capacity and punctuality on the Trieste–Venice line is represented in Figure 2(top–left).

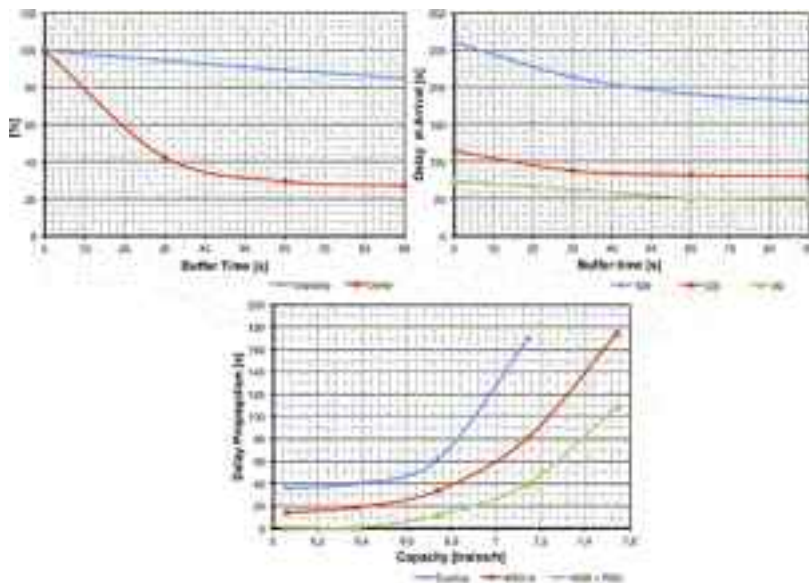

Figure 2 Trade-off between capacity and reliability.

On one side traffic quality is a function of buffer times, on the other buffer times are function of the probability of traffic conflicts (due to train movement variability). In the diagram (Figure 2, top–right) the mean arrival delay as a function of the buffer times and of the mean stochastic delay at train departure are depicted. The diagram clearly shows that the presence of heavy initial delays causes the impossibility to reach high punctuality standards although significant buffer times are inserted. In this case a detailed traffic analysis could point out delay causes and suggest strategies to overcome them. Moreover it can be noticed that a realistic buffer time estimation is impossible without a detailed stochastic phenomena evaluation which could lead to identify variability indicators to be used in the model. These indicators can be considered reliable although new infrastructure layouts or timetables could significantly modify the conditions at the border.

The method has been finally used to assess infrastructure improvement scenarios, obtaining a quantitative evaluation of their impact on both capacity and robustness. In this study the impact of the installation of regular block sections 4500 metres long to supersede the existing variable sections has been evaluated. The simulation shows that this simple interlocking improvement, consisting in the installation of one new block section and on the relocation of other three sections, leads to significant benefits to traffic robustness, allowing an increase of the available capacity (Figure 2, bottom). The reduction of delay propagation due to more regular blocking times allows a more intensive infrastructure usage, although minimal headway times remain nearly unchanged.

#### **4 Case Study: Corridor X Dobova–Zagreb–Tovarnik**

The multimodal Pan–European Corridor x will play an important economic and political role for the overall European integration and development as it will link Central and South–East Europe from Salzburg to the port of Thessaloniki.

The Croatian portion of this Pan–European Corridor represents the backbone of railway traffic from east to west on which almost all north–south lines and lines from Bosnia and Herzegovina are connected. Within Croatia, this line connects significant industrial and agricultural areas. As an example, from 1986 to 1990, more than 50% of the total freight traffic passed along this route.

For these reasons, Croatia was considering the modernisation of the Croatian section of Pan–European corridor x that is railway line Savski Marof – Zagreb – Novska – Tovarnik as a priority and therefore has identified it as a possible measure to be financed by pre–accession instruments or structural funds.

The approach for the estimation of capacity and reliability has been applied to the entire line, in order to define a series of punctual improvements that would allow the growing demand for freight slots along the corridor to be met. Differently to the other case study, in this example the reliability level was fixed for all scenarios: therefore, capacity is represented by the maximum number of trains that would reasonably lead to satisfying punctuality when considering realistic departure, running and stop time distributions.

An iterative process was defined, starting from the actual situation and ending with the complete realization of the technical improvements. In particular the following steps were performed at each iteration:

- 1 Identification through micro–simulation of the system bottlenecks;
- 2 Selection of set of actions aiming to remove the identified constraints (new scenario) and new identification of the bottlenecks of the modified system;
- 3 Further selection of set of actions aiming to remove the constraints of the previous scenario (new scenario) and new identification of the bottlenecks of the modified system;
- 4 This procedure has been cycled until the whole system has been improved to its final configuration.

At each iteration, a dense timetable was first prepared, according to the train mix included within the Master Plan. An increasing amount of buffer times was inserted until the punctuality goal was reached. The critical section was automatically highlighted as that section where the number of trains could not be increased anymore.

The proposed procedure allowed identifying a set of interventions, which are coherent among each other, within the proposed scenario and to the final configuration of the system. The considered interventions may then be considered as a gradual construction of the global design, without money losses. For each scenario the corresponding maximum traffic levels have been estimated and these values have been compared to traffic forecasts in order to predict in which year the scenario would require further improvements.

For example, in the first phase, the critical points are the main station in Zagreb, Dugo S.–Ivanic G. and Lipovljani–Novska sections, on the Dugo Selo–Novska single track line, as well as the Sunja–Novska section on the Sisak–Novska line. To overcome these restrictions the following interventions, leading to a capacity increase of about 30% along the corridor, were proposed:

- New interlocking system in Zagreb Glavni κ, including a new layout of the station in order to increase the number of independent movement within the station, thus increasing the capacity for suburban services, with 60 km/h switches. The proposed solution could avoid conflicts between the lines entering the station, producing higher punctuality and timetable stability. The proposed station layout and the new interlocking system are already arranged for the upgrade to a four-track line Savski Marof–Dugo Selo. With the proposed interventions, it is possible to obtain an increase of capacity, a running time reduction (-3 minutes) for all trains thanks to higher line speed and higher timetable robustness.
- Double track on the Dugo Selo–Precec–Ivanic Grad section, which is needed for longer suburban services; Block distance about 1500 m and discrete ETCS Level 1 was adopted.
- Double track on the Novska–Lipovljani section.
- The installation of Interlocking and block system between Novska and Sunja may allow the maximum speed possible on the existing route.
- The realization of a new station in Bljinskj Kut may double the capacity of the Sisak–Sunja section.

Table 1 briefly summarizes the interventions grouped into 4 scenarios, while Table 2 lists the corresponding capacity improvements. The critical sections at each iteration are showed on the simple network layout in Figure 3.

**Table 1** Improvement measures proposed in each scenario

SC 1	Zagreb Gl. Double track Dugo Selo–Ivanic Grad Double track Novska–Lipovljani Interlocking Sunja–Novska Station in Bljinskj Kut
SC 2	Double Track Ivanic G–Lipovljani Layout of Dugo Selo Layout of Zagreb Zapadni (60 km/h switches)
SC 3	Four tracks Savski Marof–Dugo Selo
SC 4	Freight Bypass

**Table 2** Capacity [trains/day] of each line section and scenario

		0	SC 1	SC 2	SC 3	SC 4
M101	D.G. – Zagreb	240	280	280	400	500
M102	Zagreb G.K. – D.Selo	240	280	280	400	500
M103	D.Selo – Novska	80	110	260	260	260
M105	Novska – Striz./Vrpolje	260	260	260	260	260
M105	Striz./Vrpolje – Vinkovci	260	260	260	260	260
M105	Vinkovci – Tovarnik	96	240	240	240	240
M104	Zagreb G.K. – Sisak	80	96	96	96	96
M104	Sisak – Sunja	40	80	80	80	80
M104	Sunja – Novska	16	48	48	48	48

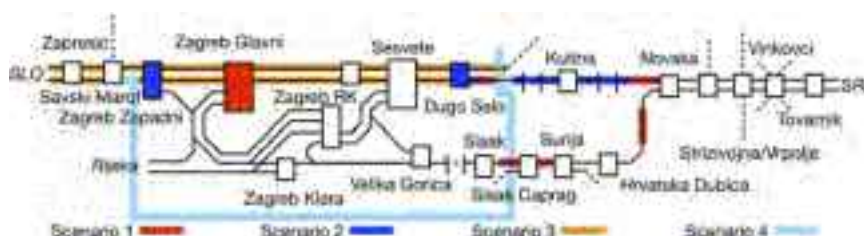

**Figure 3** Trade-off between capacity and reliability

## 5 Conclusions and Outlook

To gain competitiveness in a rapidly changing economic context, railways need efficient and effective improvements, which allow facing strength market conditions. The impact of such improvements has to be precisely evaluated, to allow choosing interventions and combining them in long-term development programs.

The presented methodology and the high detail, possible using micro-simulation models, combined with a precise model calibration, allow a realistic and comprehensive representation of the trade-off between capacity and robustness in order to evaluate timetable or infrastructure scenarios.

The first case study clearly represents the relationship between capacity and reliability, as well as the impact on both of a simple improvement in the block system. The application to the Corridor x demonstrates the applicability of the approach to long-term, gradual improvement studies even on long and complex corridors.

Both the proposed method and its results perfectly correspond to the indications of uic Leaflet 406 [6]; moreover the method allows a systematic use of its principles, which can lead to more general results. For example, in a given line section uic capacity is 246 trains/day, while simulation results indicate 260 trains/day as maximal capacity with acceptable delay propagation.

The study will be continued to consider also different interlocking and safety systems; the empirically represented relationships will be fitted in order to obtain their general analytic expression. On the basis of the obtained results new measures will also be proposed, which could better represent the performances of an infrastructure in terms of capacity and reliability and therefore be optimally deployed in multicriteria analysis.

## References

- [1] de Fabris S., Longo G., Medeossi G. 'Automated analysis of train event recorder data to improve micro-simulation models', In: Allan, J., Hill, R.J., Brebbia, C.A., Sciutto, G., Sone, s. (eds.), *Computers in Railways XI*, WIT Press, Southampton, 575-583, 2008.
- [2] Hansen, I. A., Pachel J. *Railway Timetable and Traffic*. Eurail press Hamburg, 2008.
- [3] Huerlimann, D., 'Object-oriented modelling in railways'; ETH Dissertation Nr. 14281; (in German), 2001
- [4] Kaminsky R., *Pufferzeiten in Netzen des spurgefuerten Verkehrs in Abhängigkeit von Zugfolge und Infrastruktur*. Dissertation, Wissenschaftliche Arbeit Nr 56 des Instituts für Verkehrswesen, Eisenbahnbau und -betrieb der Universität Hannover, Hannover 2001
- [5] Medeossi G., 'Capacity and Reliability on railway networks: a simulative approach', PhD Thesis, University of Trieste
- [6] UIC leaflet 406 R, Capacity. UIC International Union of Railways, France.
- [7] Željezničko Projektno Društvo d.d. (2009) *Studija Modernizacije x. Paneuropskog Koridora, HZ Infrastruktura*





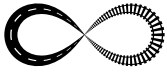

## USING SIMULATION TO ASSESS INFRASTRUCTURE PERFORMANCE IN MULTICRITERIA EVALUATION OF RAILWAY PROJECTS

Giovanni Longo, Giorgio Medeossi, Elio Padoano

*Department of Civil Engineering and Architecture, University of Trieste, Italy*

### Abstract

Economic evaluation of projects of new railway infrastructures is a typical step of feasibility studies, but it is rather common to take into account other than transport aspects of projects such as their environmental or land use outcomes. Multicriteria methodologies may support decision makers during the process of evaluation and choice of candidate projects; notwithstanding a large part of the applications in the railway sector carry out a careful analysis of the negative impacts of the alternatives, but the reasons for the actual realization of the project are neglected. In fact, a railway infrastructure project aims to improve an existing situation by means of expected positive effects on, for example, accessibility or travel times. Nonetheless, the economic revenues, the positive effects on the social sphere or the specific transportation-related matters that a project might generate are often left in the background. The authors propose a model that includes different attributes that can characterize a railway infrastructure, e.g. the flexibility rate, the comfort offered to travellers, the access times to stations, the vehicle maintenance savings, the served population, the ticketing revenues. Thus the aim of this paper is to introduce a new structure for the decision problem that includes criteria related to the positive outcomes of each alternative project as well as its negative effects. It is worth noting that positive outcomes are, to a great extent, measurable directly or they can be assessed by means of simulation models. Some of the transport-related criteria are indeed related to the inputs and outputs of stochastic simulation, which can reproduce most processes involved in rail traffic, including deterministic aspects and human factors. This is particularly relevant in order to simulate traffic under realistic conditions, considering variability at border, various driving styles and stop times..

*Keywords: multicriteria evaluation, AHP, railway traffic simulation*

### 1 Introduction

A project for a new railway infrastructure requires a series of activities that involve several competences. Among these, the assessment of different possible solutions is of paramount importance as it makes it possible to identify an effective solution. The problem of choosing among a set of candidate infrastructural projects generally implies a wide variety of decision criteria and involves many stakeholders. Therefore, the application of multi-criteria decision-making methods has been quite common in recent years (see for example, [1] [2] [3]). This paper intends to propose a new way of structuring the problem of choosing the most preferable infrastructural alternative, which allows to take into account not only the drawbacks of every possible option, but also the positive effects of each project. The main objective is to introduce a new structure for the decision problem that includes criteria related to the positive outcomes of each possible alternative, in concurrence to their well-known negative effects.

Furthermore, most of such positive outcomes are measurable directly or they can be assessed by means of descriptive or simulation models, whereas the remaining ones can be evaluated via judgements by experts. Some of the transport-related criteria, in fact, are related to the inputs and outputs of stochastic simulations, which represent a fundamental support tool in the development of railway projects.

## 2 The problem of choice in railway projects

Transportation infrastructural projects involve large amounts of resources and have effects on several aspects relating to the social sphere and to the environment. It is then clear that they drive the attention of subjects, organisations and communities that could be affected. In general, these kinds of projects are starting to solve mobility problems or to take up funding opportunities. It is rather common to carry out a feasibility study in which different solutions are identified and characterised at a sufficient level of technical detail. Often the solutions are structured in the form of 'alternatives' which form a set of mutually exclusive elements; this poses a problem of choosing the one that is the most effective for achieving the objectives of the project. Therefore, this part of the project requires analysis, evaluation and decision with respect to the set of the technically feasible alternatives.

In order to take into account different points of view that may be interested by the project implementation, the alternatives are frequently submitted to a discussion process in which several stakeholders participate directly or by means of nominated experts (actors of the process – see e.g. [4]). The role of the experts is to examine in detail the characteristics of the alternatives from different perspectives of analysis and evaluation (technical, economic, social, environmental etc.), supporting the reasons of the dimension pertinent to their expertise and the arguments of the stakeholders who they represent. Actors' judgments might diverge: in such cases the most robust opinions are those that come from the more legitimated participants (because of their role or expertise) or those that are based on the most solid argumentation (Saaty, 2008). A proper analysis and assessment of the solutions can be assured by considering two aspects:

- structuring a framework to support the examination;
- identification of the criteria for the evaluation that are pertinent to the decision.

The analysis and evaluation requires, on one hand, that the peculiar attributes of the alternatives should be put into evidence and, on the other hand, that the criteria for evaluation should be clearly stated. A framework that helps to perform practically this task is therefore advisable. Several authors (e.g. [6] [7]) have observed that a hierarchical structure is particularly effective: from the main objective (or goal) of the decision problem it makes it possible to detail progressively the evaluation criteria up to a level that can be used to assess the alternatives. This kind of structure is employed in the Analytic Hierarchy Process (AHP) multi-criteria method.

The identification of the criteria should take into account different stakeholders' objectives and the main goal of the project. Most of the applications concerning transportation infrastructures frequently offer an in-depth analysis of the 'negative' attributes related to the candidate solutions (impacts), without detailing thoroughly the positive outcomes attributable to the project. It is evident that when a new infrastructure is proposed, a positive effect is foreseen; nevertheless aspects such as capital costs and environmental impact are often the most accurately measured. Nonetheless, topics like possible economic revenues, positive effects on the social sphere or specific transportation-related matters are left in the background. Figure 1 shows a hierarchy that includes the main dimensions of evaluation that are traditionally taken into consideration in multi-criteria decisions concerning railway infrastructures.

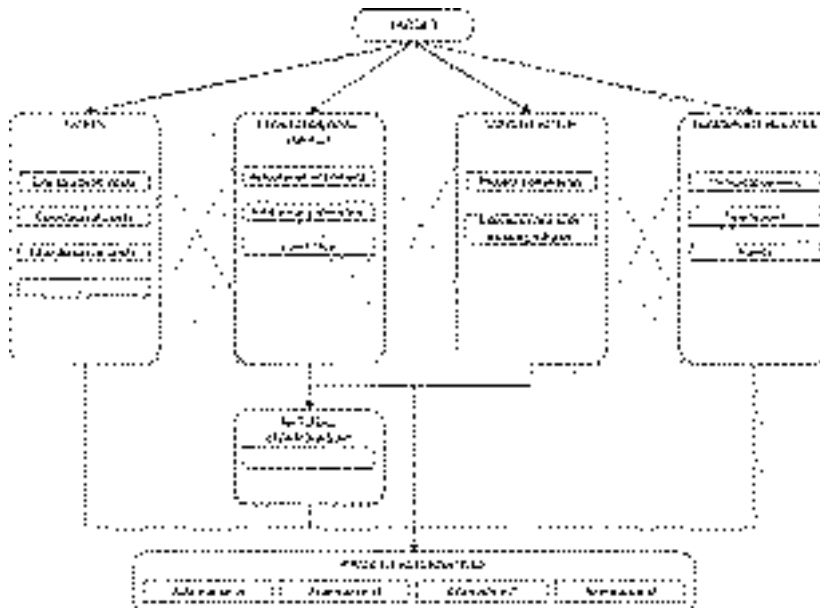

Figure 1 A hierarchy of criteria to assess railway infrastructures

Such problematic issues can occur more frequently when priorities have to be assessed to objects (criteria or candidate solutions) that have a 'rough' definition or that can be perceived in very different ways (a typical example is the criterion 'aesthetics'). An effective definition of performance measures is particularly important in the field of transport infrastructure to build a solid argumentation. It must be underlined, though, that technical data or functional models are not meant to replace a confrontation on a subject of the decision process, but they constitute a fundamental support tool to make sound decisions.

### 3 The proposed model

The proposed model includes criteria pertinent to different dimensions of evaluation and takes into consideration attributes that are commonly considered as positive effects or as negative outcomes of an infrastructural project [8]. The decision problem is structured as a hierarchy (Figure 2). At the first level the criteria are grouped into four categories: 'Economic and Financial', 'Transport-related', 'Social' and 'Environmental'. Some of these dimensions are further developed in subcategories, grouping subcriteria into more detailed and specific clusters.

Two dimensions are commonly included in many studies related to transportation infrastructures: Economic and Financial criteria and Environmental Impact indicators. With reference to the first one, along with criteria like 'capital investment' the model proposes to take account of the different 'ticketing revenues' related to each alternative solution, which depend on the served traffic demand in each situation, as well as of revenues obtained through the 'lease or sell' of station facilities and the 'savings' in terms of infrastructure and rolling stock 'maintenance'. So far as the Environmental impact indicators are concerned, several authors (e.g. Pak, Tsuji and Suzuki, 1987) already specify all possible outcomes to be included in the analysis: impacts on the 'natural environment', damage to the 'historical patrimony', effects on 'land use'. The evaluation of all of these aspects can be further detailed as required by the specific decision problem, usually structuring the problem situation in a number of hierarchically dependent subclusters.

When facing a decision problem regarding the choice among alternative railway infrastructures, social aspects are also significant and may favour one alternative instead of another. These include the 'served population', the 'employment' related to the building site, the 'real estate value increase' for those regions linked by the new line, the 'access times' necessary to reach a station from a specific point of interest and the possible 'reuse' of the construction area for other purposes (gardens, parking lots etc.).

To integrate these criteria, the new decision structure proposes a set of performance measures that characterise solutions from a technical point of view; the set is detailed in the next paragraph. Several of these criteria are associated to parameters or indicators that can be directly measured, or that can be assessed by means of analytical or simulation models applied to transportation networks.

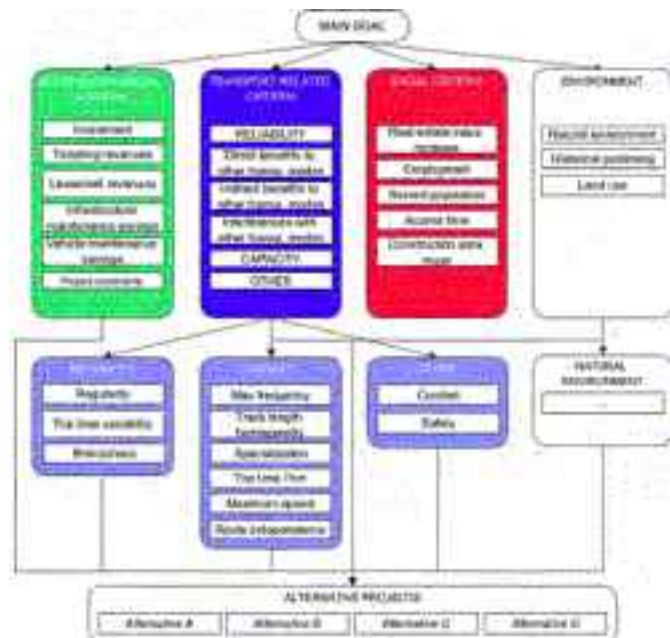

Figure 2 The hierarchy of the proposed model

## 4 The transport-related criteria

As shown in Figure 2, the model identifies several criteria that are specific of railway decisions (either concerning station layouts or line projects). Direct benefits can derive from the solution of existing conflicts among infrastructures – such as at-level crossings between railway lines and roads – which results in a rise of capacity at system level. Indirect ones, instead, are related to the modal shift of part of the mobility demand from the surrounding roads to a new railway line or station. Besides, also new interferences among transport modes may arise from the realisation of a new infrastructure, which may influence, for instance, the way the traffic flows in the surrounding areas.

The rate of reliability of railway networks is a crucial aspect in the choice among alternative projects and can be quantified through three criteria closely related to railway simulation outputs: regularity, which may be measured in different ways such as for example the average delay in perturbed conditions; trip-time variability, i.e. its standard deviation obtained by

stochastic micro-simulation (described in the next paragraph) and robustness, a measure of the reliability of a network (e.g. a station yard layout) (see [12]).

Another fundamental characteristic is capacity, both for station yard layouts and for railway lines. Capacity, the result of a mix of criteria closely interconnected with each other. The whole set of indicators can provide an idea of the right compromise between the number of trains running per time unit and the degree of regularity of circulation, which in turn influences the complexity of operations. Therefore, this aspect can be treated in a specific subcluster containing a number of nodes, depending on the specific case study: maximum departure frequency (in trains/h), trip time per kilometre and maximum speed (km/h) are self-evident concepts. In addition to these, one may include the rail track length homogeneity within a station, in terms of number of module-long tracks over the total number (the 'module' being the maximum length of trains that can circulate on a line, which depends on the track length in crossing station yards). Other criteria, that are related to infrastructure capacity are the specialization rate of a station layout, an indicator of the possibility of separating the different train services (commuter, long-range and freight for example – a higher of separation results in a higher capacity, as slow trains do not influence the flow of the fast ones) and independence rate among itineraries within a station. The last aspect is specified better in the next paragraph.

#### 4.1 Simulation

Stochastic micro simulation can model train operations and reproduce most processes involved in rail traffic. It comprehends not only its deterministic aspects, but also human factors thus considering the real behaviour of trains and representing signalling, ATC systems, and other technical parameters. Simplified dispatching is also provided by local conflict resolution, and stochastic train behaviour can be inserted using multiple simulations. Starting from a precise infrastructure model, a planned timetable and the rolling stock characteristics, micro-simulators use a mixed discrete/continuous simulation process that calculates both the continuous numerical solution of the differential motion equations for the vehicles (trains), and the discrete processes of signal box states (figure 3). It may be used to estimate the system behaviour in different scenarios.

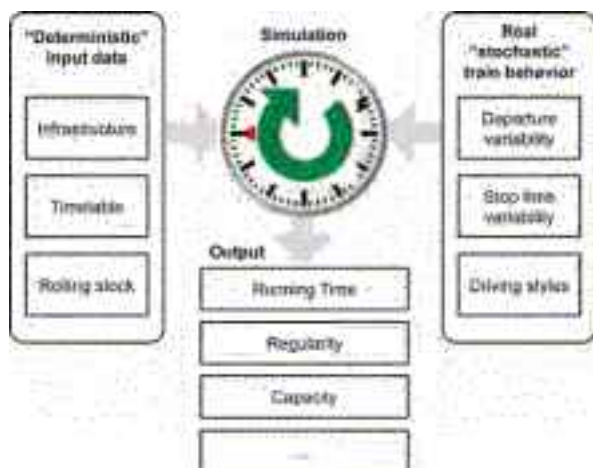

Figure 3 Input and output of railway micro-simulation

Stochastic micro-simulation can be seen as a very precise way to model train operations on a network, obtaining knock-on delay and punctuality estimations and allowing users to evaluate various rolling stock, infrastructure layouts and timetable.

It can be used to obtain a number of parameters strictly related to the behaviour of the system, such as punctuality ('regularity'), 'trip time variability', and even 'capacity' indicators, especially when the trade off between capacity and reliability is considered. These aspects are usually very important in new railway projects assessment as the increase of capacity (to serve increasing demand flows) and the improvement of traffic reliability are main goals in many countries.

## 4.2 Itinerary independence

Thanks to the integration of the micro-simulation model and worksheets macro programming, the calculation of some capacity indicators may be automated and it has been tested on a complex railway node. In particular, starting from the station layout elements that constitute part of the simulation input, the script is able to calculate all possible  $n$ -uples of independent itineraries that can be run through at the same time. Each itinerary within a station is described as a sequence of nodes in the simulation model. Each of these sequences is compared to all others, thus highlighting the existing conflicts. The second step is to compare each couple of the previously calculated independent itineraries with the remaining itineraries, so as to determine a set of independent triples. The process is then iterated  $n$  times by comparing all  $n$ -uples of independent itineraries with all other routes, until no  $(n+1)$ -uple of independent itineraries can be found. Joining the independence information and the train service timetable, a common itinerary independence index is also obtained – the weighted route locking rate. The timetable is fundamental to weight each itinerary with the number of trains that are planned to run through it. When comparing two alternative infrastructure projects, a lower locking rate would be preferable, as it indicates the possibility of shunting a higher number of trains per time unit.

This approach has been successfully applied to complex Italian railway nodes. The degree of independence among itineraries brings a lower risk of conflicts among trains running through a station and therefore provides a higher capacity in terms of possible services per time unit.

## 5 Conclusions

The proposed multiple-criteria decision structure aims at satisfying the lack of quantitative information noticed in a number of project evaluations in the field of railway infrastructures. This lack in particular refers to the estimation of positive performances of the alternatives, while usually their negative externalities are well known and quantified. The intention is not to belittle the importance of utility judgements, but the authors' opinion is that this way of structuring the problem may aid decision makers in deeply understanding the significance of each analysed project. Thus, decision makers could then evaluate the performance of the alternatives according to their judgement scales, relying on a solid technical basis. The proposed criteria were obtained in a number of major Italian railway nodes proving to be based on robust and reliable methodologies. They allow the measurement of some aspects, whose importance in railway projects assessment is really high.

Among the possible future developments, the presented model could be further enhanced by analysing more deeply the role of each actor in the decision stages and by specifying all possible interrelationships among actors and criteria through an ANP (network) structure. Criteria may also be arranged in a flexible BOCR, by evaluating Benefits, Costs, Opportunities and Risks associated to each alternative separately.

## References

- [1] Barić, D., Radačić, Z. & Čurepić, D.: Implementation of Multi-criteria Decision-Making method in selecting the railway line for reconstruction, 10th International Conference on Transport Science, Portoroz, 2006.
- [2] Tsamboulas, D.: A tool for prioritizing multinational transport infrastructure investments, *Transport Policy*, 14, pp. 11-26, 2007.
- [3] Mateus, R., Ferreira, J.A. & Carreira, J.: Multicriteria decision analysis (MCDA): Central Porto high-speed railway station, *European Journal of Operational Research*, 187, pp. 1-18, 2008.
- [4] Banville, C., Landry, M., Martel, J.-M. & Boulaire, C.: A stakeholder approach to MCDA, *Systems Research and Behavioral Science*, 15, pp. 15-32, 1998.
- [5] Saaty, T. L.: Relative Measurement and its Generalization in Decision Making. Why Pairwise Comparisons are Central in Mathematics for the Measurement of Intangible Factors. *The Analytic Hierarchy/Network Process*, RACSAM, 102(2), pp. 251-318, 2008.
- [6] Hwang, C-L, Yoon, K.: Multiple attribute decision making: methods and applications : a state-of-the-art survey, New York: Springer-Verlag, 1981.
- [7] Saaty TL.: Fundamentals of decision making and priority theory with the Analytic Hierarchy Process. First edition, Pittsburgh, PA: RWS Publications; 2000.
- [8] Longo G., Padoano E., Strami S.: Improving the assessment of railway projects through new performance indicators, EURO XXIV Lisbon, 24th European Conference on Operational Research, 2010.
- [9] Pak, P. S., Tsuji, K. & Suzuki, Y.: Comprehensive evaluation of new urban transportation systems by AHP, *International Journal of Systems Science*, 18(6), pp. 1179-1190, 1987.
- [10] Hansen, I.A., Pachl, J.: *Railway Timetable and Traffic*. Eurail Press, Hamburg, 2008.
- [11] Hürlimann, D., Longo, G., Medeossi, G.: Stochastic micro-simulation as a timetable robustness estimation tool. In: *Third International Seminar on Railway Operations Modelling and Analysis*, Zurich, 2009.
- [12] Lamanna F., Longo G., Medeossi G.: Robustness and Protection Strategies of Station Tracks Layout. A New Approach Based on Complex Networks Theories' In 'Proceedings of the 4th International Seminar on Railway Operations Research (ISROR)', 2010.





## 3 INFRASTRUCTURE PROJECTS



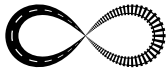

## SPECIFICITIES OF PROJECT FOR RAILWAY LINE ON CORRIDOR VIII

**Zoran Krakutovski, Darko Moslavac, Zlatko Zafirovski**

*University sts. Cyril and Methodius, Faculty of Civil Engineering Skopje,  
Republic of Macedonia*

### Abstract

The project regarding construction of the new railway line, part of the TEN Corridor VIII through the area of R. of Macedonia, is in the advanced stage of study and design preparation. The railway line on Corridor VIII starts in Durres (Albania – port in the Adriatic Sea), going by Tirana, Skopje, Sofia, Plovdiv, Burgas and the other endpoint is in Varna (Bulgaria – port on the Black Sea). There are two missing sections for construction of new railway link in R. of Macedonia: the first is on the East (link with the railway network in Bulgaria), and the second is on the West (link with the railway network in Albania). The part on the East has been started with construction in 1994 with proper governmental financial resources, but this manner of investment is abandoned in 2000. The usage of European financial institution is a new approach to find stable financial funds for complete construction of this part of railway line. The starting point for project concerning the part on the West is preparation of general study and tracing of feasible railway line variants and preparation of feasibility study. The feasibility study for the West part is finished and for the East part is going currently. The next step of this project is to complete the Detailed Design and to prepare the tender documentations. The study until now shows some specificities of this railway line and its importance for national and international transport. The construction of missing segments on the railway line is envisaged to start in 2013.

*Keywords: railway line, corridor VIII, corridor X, design, pre-feasibility study*

### 1 Introduction

The Republics of Albania, Macedonia and Bulgaria in 1992 agreed on a transport Corridor Durres–Tirana–Gostivar–Skopje–Kumanovo–Gueshevo–Sofia–Burgas in a Memorandum of Understanding (South Balkan Development Initiative, Bechtel Report on East–West Transport Corridor Feasibility Study, 1997). This is the forerunner of Corridor VIII, the southernmost among the West–East Pan–European Corridors, linking the Adriatic/Ionian to the Black Sea Pan–European Transport Areas. The main alignment of Corridor VIII runs from the southern Italian ports of Bari and Brindisi, the Albanian ports of Durres and Vlora, the cities of Tirana, Skopje, Sofia, Plovdiv, to the Bulgarian ports of Burgas and Varna (Black Sea), thus connecting the Italian Adriatic Transport Corridor, the Adriatic branch of Motorway of the Sea and the Mediterranean Transport Area to the Black Sea Pan–European Transport Area.



Figure 1 Pan-European Transport Corridors in the Soud Europe

## 2 Rail Corridor VIII description

The Corridor starts from the ports of Bari and Brindisi in Italy, and through the port of Durres and Vlore in Albania reaches the capital Tirana. The rail connection continues on towards the boundary between Albania and Republic of Macedonia. After crossing the border the main route continues northward, passing through the city of Tetovo and ultimately reaching the capital city of Skopje; from there the route continues moving East, running along the main line, which crosses all of northern part of Republic of Macedonia, up to the zone bordering on Bulgaria until it reaches the port of Burgas on the Black Sea.

Rail Corridor VIII forms a network with Rail Corridors X, IV and IX. The interconnection nodes are in Skopje, with Corridor X; in Sofia, with Corridor IV; and in Gorna Oriahovica, with Corridor IX. The entire line, including missing links, is 586 km long, of which 139 km are in Albania, 309 are in Republic of Macedonia and 138 km are in Bulgaria. The line is composed by a single track segment, suitable for diesel traction trains.

The entire line from Durres to Sofia has been divided in 17 sections, identifying 3 main categories: the existing railways on which no immediate intervention has been envisaged, the sections already built which require rehabilitation or upgrading and, finally, the sections where the rail line is completely missing or is currently under construction.



Figure 2 Rail Corridor VIII main alignment and connections with other corridors

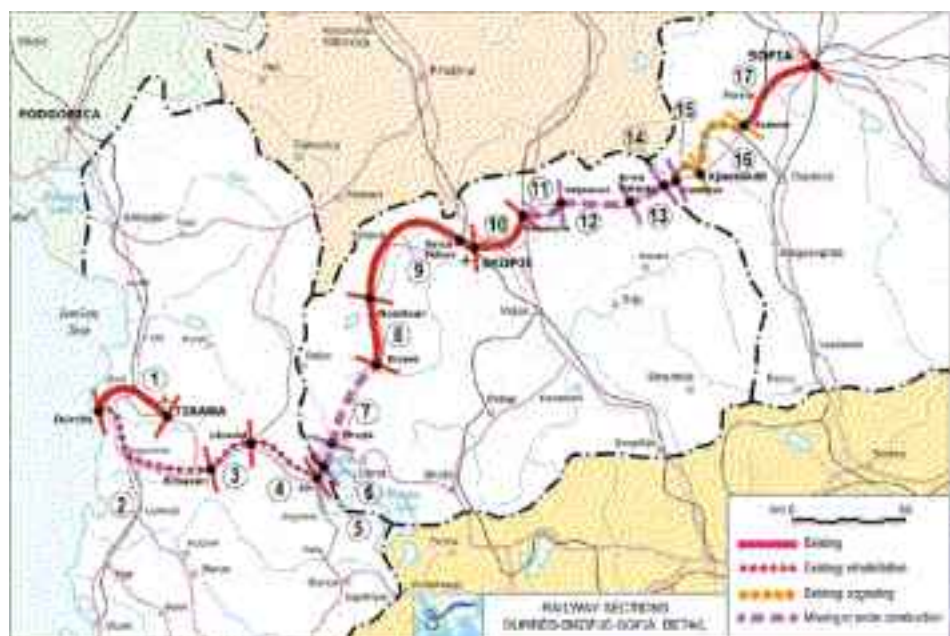

Figure 3 Details of Rail Sections Durres–Skopje–Sofia

### 3 Part of Corridor VIII through the territory on Republic of Macedonian

#### 3.1 Section Lin – Macedonia border (Section n.5)

This section, 2–3 km long, is one of the missing links along the rail Corridor VIII alignment.

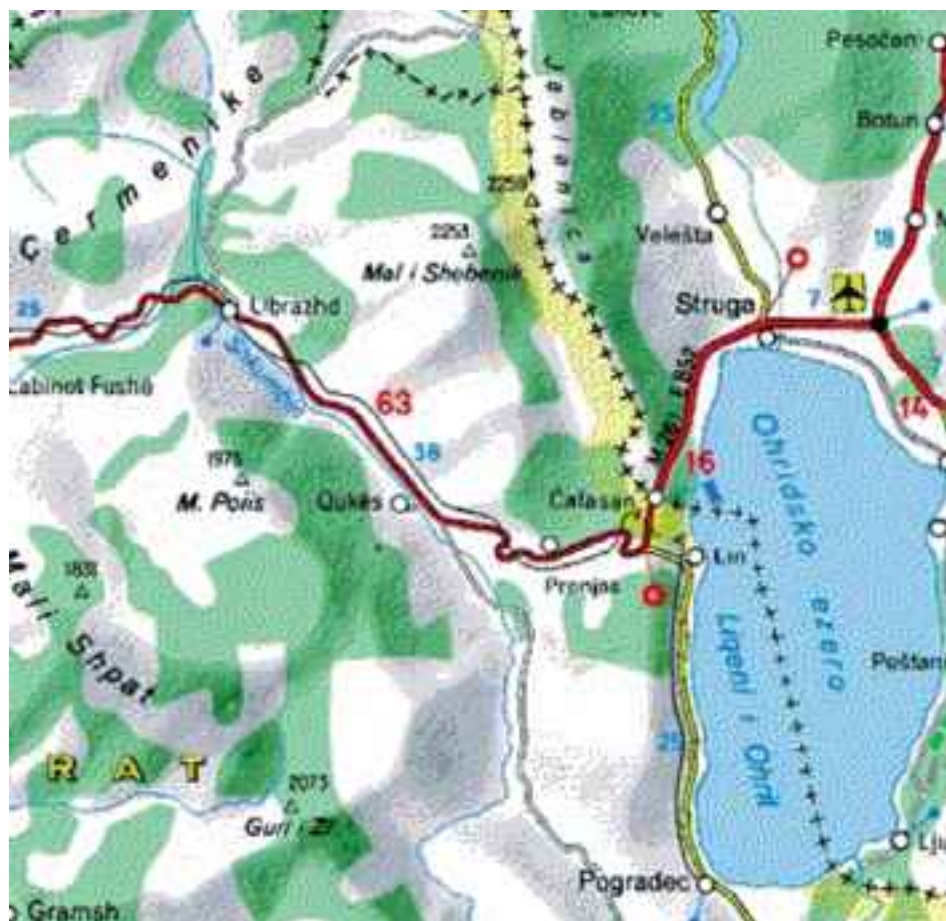

Figure 4 Albania – Macedonia cross border rail missing link

#### 3.2 Macedonia rail sections (from Section n. 6 to Section n. 13)

Eight rail sections have been identified: Albanian border–Struga–Kicevo (Sections n. 6–7 missing link), Kicevo–Kumanovo (Sections n. 8–9–10, existing with minor upgrading between Kicevo and station Gorce Petrov), Kumanovo–Beljakovci–Kriva Palanka (Sections n. 11–12, under construction) and Kriva Palanka–Bulgarian border (Section n.13, missing).

### 3.3 Albanian border–Struga–Kicevo (Sections n.6 and n.7)

These sections, which are 66 km long, are missing. Section n.6, from the Albanian border to Struga, is 12 km long, while section n.7, Struga–Kicevo, is 54 km long.



Figure 5 Macedonia Rail Sections: Albanian border–Skopje–Bulgarian border



Figure 6 Kicevo Station: terminal of the existing railway line towards Albania



### 3.4 Kicevo–Gostivar–Gorce Petrov–Skopje–Kumanovo (Sections n. 8–9–10)

This alignment is the existing, 154 km long, central part of rail Corridor VIII in Macedonia. West of Skopje, there are the Kicevo–Gostivar (36 Km) and the Gostivar–Skopje (81 km) sections; East of the capital city there is the Skopje–Kumanovo section (37 km). The operating speed is around 60 km/h and only the section Skopje–Kumanovo is electrified, the others are suitable for diesel engines only. The signaling–interlocking system and the telecommunication equipment are twenty years old but still in good shape.

Louis Berger, in its study 'Investment Options in the Transport Sector component 5: Rail Link to Albania', investigated the 103 km West of Skopje (the section Kicevo–Gorce Petrov) for upgrading the line Kicevo–Skopje in order to achieve a sustainable speed of 100 km/h.

### 3.5 Section Kumanovo–Beljakovci (Section n.11)

This line is under construction. Design parameters are the following:

- Speed: 100 km/h
- Min curve radius: 500 m
- Max axle load: 250 KN
- Max gradient 15 ‰
- Bridges: 8, total length 224 m
- Rail station: 1



**Figure 7** Rehabilitated section Kumanovo – Beljakovci

This section, which is 29 km long, is completed for about 35 %, in terms of financial resources already spent, i.e. 13 million € over a total sum of 37 million € required to reach Kleceve. From this village a 6 km rail track, including a new bridge, must be constructed to reach Beljakovci. The additional investment are needed to complete this section, including signaling and electrification as well as an intermediate rail station.

### 3.6 Section Beljakovci – km 66 (Kriva Palanka) (Section n.12)

This 37 km long section is also under construction. Basic technical parameters are the following:

- Speed: 100 km/h
- Min curve radius: 500 m
- Max axle load: 250 KN
- Max gradient 15 ‰
- Bridges: 33, total length 3,985 m
- Rail stations: 3
- Overpasses: 8, total length 273 m
- Tunnels: 15, total length 3,437 m
- Embankments: 12,295 m
- Cuttings: 16,509 m



**Figure 8** Viaduct in construction on the section n.12 Beljakovci–Kriva Palanka

The section Beljakovci–km 66 ends 7 km before reaching the town of Kriva Palanka. This section is completed for about 58 %, in terms of financial resources already spent: 90 million € over 155 million € of total resources required. The last constructed bridge is about 7 km before Kriva Palanka. The additional investment are needed to complete the single electrified line including signaling and telecommunications. Works have stopped two years ago because of lack of funding. Construction materials are nearly entirely produced in Republic of Macedonia.

### 3.7 Section from Km 66 (Kriva Palanka) to Bulgarian border (Section n. 13)

This section, 23 km long and running through mountains, is missing. The Detailed Design for the alignment and also Preliminary design for structures (bridges and tunnels) is finished. From the available technical documents the following parameters can be derived:

- Speed: 100 km/h
- Min curve radius: 500 m
- Max axle load: 250 KN
- Max gradient 25 ‰
- Bridges: 41, total length 4,544 m
- Rail stations: 2
- Tunnels: 25, total length 8,593 m
- Embankments: 3,056 m
- Cuttings: 6,659 m

The investment costs amount to some of 105 million € for a single electrified line. The main part of the required sum will cover the needed civil works (including the tunnel to reach the Bulgarian border), adding to about 95 million €.

## 4 Conclusions

The missing sections of railway line on Corridor VIII, through the territory of Republic of Macedonia, are in the final stage of preparation of design documentation. The start of the works is envisaged to be in 2013. The financing of this project will be realized from European banks and funds.

## References

- [1] Pre-feasibility study on the development of the railway axis, final report september 2007, Ministry of International Trade – Italy, CEI (website:www.corridor8.org)
- [2] European Commission, Trans-European transport Network, TEN-T priority axes and projects 2005, Brussels, 2005.
- [3] SEETO Working Group on Railways and Intermodality, Report to the Steering Committee, draft of January 22, 2007

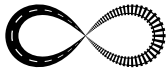

## MODERNIZATION OF RAIL ROUTE 10 – KOSOVO RAILWAYS

Fitim Shala

*University of Pristina, Faculty of Civil Engineering and Architecture, Kosovo*

### Abstract

The paper describes main objectives and conclusions drawn from the creation of the study 'Modernization of Rail Route 10' which aims to help the Kosovo Railways to attract the interest of international financing institutions for further pre–investment studies. The overall objectives of the study are to prepare a package of short term improvements, which comprise of repair programmed for track and structures to bring the line to the designed speed and to draft a medium–long term development scenario that will include higher line speed up to 160 km/h and electrification. Following the status and objectives of this study, including the outlines stated in the defined the reference options as follows:

- option 'short term', as 'option 1', and
- option 'medium–long term', as 'option 2'.

*Keywords: railway infrastructure, higher speed, traffic load, safety, environment.*

### 1 Introduction

Rail Route 10 'North–South' traverses over Kosovo territory from the border with Serbia (station Leshak) to the border with Macedonia (station Hani i Elezit). The line is 148km long within the territory of Kosovo. The line was originally built in 1893 and it is not electrified up to the date. The last track renewal along the line was carried out in period 1974–1975. Rail Route 10 sustained the highest rate of damages in period 1990–1999. So far, these damages have been partially repaired. The level of regular superstructure and substructure maintenance in that period was reduced to a minimum resulting in sub–standard condition of the line with the maximum speeds reduced to 60–70kph along the line. In some specific cases, the maximum speed is reduced to even 20kph because of safety reasons (sections with tunnels).

The line justifies the intervention, since 35 years elapsed from the last track renewal. Superstructure components are worn–out, which led to general reduction of speed limits to 60km/h along the whole line, although major part of the line was originally designed for 100–120km/h, except on hilly sections where the maximum designed speed was 70km/h. Substructure components also require rehabilitation and improvements, since 15 bridges have C4 load classification (less than D4 required) and 13 tunnels have lining rehabilitation problems, which led to further speed limits of 20km/h in four extreme cases due to safety reasons. Furthermore, 5 tunnels on section Leshak–Mitrovice require cross–section improvements in order to eliminate technical and operational restriction for high–cube containers. Fushe Kosove junction (stations Fushe Kosove and Miradi) is not equipped with interlocking at all, although it is the main railway junction in the country. A lot of efforts were implemented by KR on introduction of the CTC along the whole line, but there are still substantial requirements in other stations to enable the full integration. There are 105 level crossings, of which 16 are interlocked and this presents a special problem for further treatment.

The study drafted the alignment for do–maximum option, which would be 130.5kms long (approx. 20kms shorter than the existing one), with 9.2kms of bridges and 14.8kms of

tunnels. Each bridge and tunnel was elaborated as a single-structure for a double-track line, which substantially affected the reduction of the estimated construction costs. Along with the substructure, superstructure, signaling (interlocking, telecommunication and level crossings) and electrification components, the total investment costs are estimated at 513.1 million.

## 2 Background and objectives of the study

The bases for implementation of this project are the identified core railway network within the activities of SEETO (South-East Europe Transport Observatory). The purpose of the SEETO is to promote the regional cooperation in development of multimodal core regional transport network of the South-East Europe, as well as the support to the implementation of investment programmers within this network. One of the main results of the SEETO activities is the identification of such network, including the core railway network.

SEETO's core railway network are railway routes taken from the concept of the Pan-European Corridors and additional railway routes, which are assessed as important for development of multimodal core regional transport network of the South-East Europe.

Under this concept, Rail Route 10 presents the existing railway line in total length of 252kms with general orientation Kraljevo (Ser)–Pristine (Kos)–Gorce Petrov (Mcd). Following this concept, Government of Kosovo drafted the Multi Modal Transport Strategy, addressing this to the Rail Route 10 (148kms) located within Kosovo territory (Leshak–Hani i Elezit/North–South railway line).

Under the framework of former Yugoslav Railways network, Corridor x connected Belgrade via Lapovo and Nis with Skopje (MKD). Rail Route 10 branched in Lapovo between Belgrade and Nis, forming another route to Skopje: Belgrade–Lapovo–Kraljevo–Fushe Kosove–Skopje. The design speed along Rail Route 10 was 100–120km/h between Mitrovica and Gurez, where the Line runs in a valley with wide or no curves at all and without substantial gradients. South of Gurez and north of Mitrovica to Kraljevo, the Line runs in canyon areas with narrow curves of 250–300m radius, 17–19‰ gradients and many tunnels and bridges. The design speed along these two sections of the Line is 60–70km/h.



Figure 1 Core Railway Links in the SEETO Network



Figure 2 Railway Network in Kosovo

In 1980–ies, the modernization of the Line started with new signaling systems installed ('Ericson' along Rail Route 10). The signaling systems were designed and prepared for operation under the electrified railway line conditions. The electrification of the present Rail Route 10 was studied but it was never implemented, so the Line remained non-electrified. In that period, Rail Route 10 served mainly the mining and metal industry located between Fushe Kosove and Kraljevo. It was also used for transit trains throughout Kosovo to Skopje and further to Greece. Irrespective to Corridor x, Rail Route 10 has not received much attention so far and has suffered of war damages and political troubles. In the recent years, Kosovo railways have gradually repaired the war damages and restarted a limited train service for passengers and gained a growing number of cargo transports. At the moment, restructuring process, where the next step will be the separation of the infrastructure from transport operations.

Kosovo is a partner in SEETO and will be a signatory to the new West Balkan Transport Treaty. The treaty requires open access and interoperability to be achieved, which is one of the important issues for consideration under this study.

The Project has to reach the following objectives for both cargo/freight and passenger transport:

- to provide reliable access to railway services customers with relatively high availability of infrastructure capacity (one train path per hour);
- to provide certain quality in signaling and telecommunication components of the railway infrastructure for facilitation of operations along the line in accordance with the contemporary standards recognized by certain international institutions and safety integrity level requirement;
- to eliminate physical bottlenecks for safe and regular railway operations, including the contemporary transportation facilities such as Ro-La, high-cube containers, etc.;
- to provide higher level of service (standards for the upgrade of the line up to 160km/h) including the electrification, once this upgrade is justified by traffic demand.

Objectives of the Study are the following; to prepare short term improvements, which comprise to bring the line to the designed speed and to draft a medium-long term development scenario that will include higher line speed up to 160 km/h and electrification.

### 3 Option 'medium–long term'

This medium–long term option n includes the maximum scope of interventions, which refers to the reconstruction of all infrastructure components in order to reach maximum speed at 160km/h along Rail Route 10. This option also includes construction of the double–track line and electrification of it for the stated speed.

This is considered a medium–long term option and a conceptual technical design has been pre–formed within the scope of the study, as part of the pre–feasibility assessment. This option includes the designed speed of 160km/h for passenger trains and 120km/h for freight trains along the Line. This requires substantial rectification of the sections of the Line placed in the hilly areas (Leshak–Mitrovica and Gurez–Hani i Elezit). Besides that, this option requires the following observations in terms of track geometry against the estimated investment costs:

- construction of single structures (bridges and tunnels) for carrying the double–track line,
- designed speed for running lines in stations,
- status of level crossings.

Interlocking and telecommunication equipment requires certain adjustments in comparison to 'do–something' option. Besides the previously identified activities, it will be necessary to install GSM–R communication system and to provide protective installations for electrified lines on the equipment, including the 100% GSM signal coverage along the Line.

The electrification of the Line requires installation of substantial equipment (OCL, substations, etc.) for a double–track line system.

So, option do–maximum creates the substantial upgrade of the Line and makes it identical to the standardized infrastructure components of majority Corridor railway lines under the SEETO concept.

### 4 Technical Options

The track renewal activity along railway line Leshak–Hani i Elezit has been already assessed as necessary, since the last renewal was carried out in mid 1970–ies and the condition of the track components requires this activity in order to prevent its further deterioration and to meet expected traffic demands. The experts assessed two alternatives for the track renewal, which are based on different track components. One alternative is based on rail type UIC60E1, reinforced concrete sleeper 2.60m long, elastic fastening and eruptive stone ballast, whereas the another alternative is based on rail type 49E1, reinforced concrete sleeper 2.40m long, elastic fastening and limestone ballast. The proper attention is also given to the situations at tunnels, bridges and stations.

### 5 Superstructure

#### 5.1 Rails

There are two types of rails, which were assessed by the experts, 49E1 and UIC60E1. There are several technical and operational elements, which have the influence on selection of a rail as follows:

- type and annual volume of traffic,
- axle load,
- speed of trains, especially in curves affecting the cant,
- curve radius,
- impact of rising and falling gradients,
- type of rolling stock.

The expected traffic along Rail Route 10 in Kosovo is mixed with annual volume of traffic in range of 7.5–11 millions gross–tons. For such traffic volume range, experience showed that the expected lifetime of rail UIC60E1 is 5 years longer than of rail 49E1. That is based on the period between two complete track renewals, which is 25 years (maximum 30 years) for UIC60E1 and 20 years for 49E1 (maximum 30 years).

The expected axle load along Rail Route 10 will be 22.5 tons and classified as D4 category. Both rail types meet this requirement but rail UIC60E1 can bear 25 tons axle load, which puts another important advantage to this rail type. The fostered trend of productivity increasing in freight traffic specially, asks for further improvements of maximum axle loads on existing infrastructure, at least along the major corridors or lines.

## 5.2 Sleepers and fastening

For the open line, except in tunnels and steel bridges without the ballast, there are two type of sleepers assessed. The first one is the concrete sleeper of type 'JZ 70', which has already been used along the line. This sleeper was 2.40m long and fastened by 'K' fastening to rail 49. Another one is the monobloc reinforced concrete sleeper, which is 2.60m long. The procedure for assessment of suitable sleepers and fastening is similar to the rails. It also includes the same technical and operational elements as for rails, because it is required for sleeper to go in combination with the rail and the fastening. Longer reinforced concrete sleepers with higher support surface are proven as more suitable for amortization of static and dynamic stresses caused by train movements in general.

Based on Rulebook 314, reinforced concrete sleepers can be installed in the track with curves of radius equal–higher of 250m. Following this Rulebook, it is compulsory to install wooden sleepers in tunnels and on bridges without ballast. So, tunnels and bridges without the ballast will have sleepers made of oak with dimensions 26x16x260cm, which was originally foreseen by the Main Design made in 1984, but was never implemented.

## 6 Electrification of the existing line

In addition to the aforesaid components, the experts considered the electrification of the existing line based on the previous technical elaborations.

### 6.1 Overhead Contact Line

The contact wire is of Ri 100 type, no. 65. At locations of pylons, the stitch–wire suspension, in length of 12.5m, is foreseen in order to implement more uniform elasticity of the OCL in combination with the pantograph. The tensioning is separated between the contact wire and carrying cable. The total length foreseen for the electrification in terms of the OCL is 179kms, which includes the open line and tracks in stations along the line.

### 6.2 Power Supply Plants

The substations are foreseen at locations Vallac, Miradi and Gurez. Also, 4 locations of the sectioning point with neutral line are foreseen with 4 switches in order to enable parallel power supply of the contact wires on both tracks and longitudinal separation of the sections. The disconnecting switches for power with engines are foreseen in stations. The power supply along the line has to be considered for 2x25kV system.



## 7 High speed track and structure solutions

Considering that the existing technical elements of Rail Route 10 do not meet conditions for a train speed at 160km/h, the experts designed the variant of the alignment at the conceptual level with more favorable geometry elements as a double-track line. The digitized topography maps in 1:25,000 scale were used, from which the digital terrain model was created with sufficient precision for this level of design.

The experts used design standards taken from former Yugoslavian Railways, which are in principle based on several Rulebooks, such as 314 (superstructure) and 315 (substructure), standard for a railway tunnel design, etc. The experts also used other international standards, such as European Norms for track geometry for instance, in order to obtain the consistent technical solution, as much as possible, at this level of design.

The following geometry elements of the alignment have been selected by the experts for design of the double-track railway line at designed speed 160km/h:

- minimal horizontal curve radius:  $R=1,100\text{m}$ ,
- minimal length of the transition curve:  $L=240\text{m}$ ,
- maximal gradient:  $i=15\text{‰}$ ,
- distance between centers of track: 4.00m on open track and 4.75m in stations.

The maximum development is a medium/long term scenario, in order to achieve double track, electrified railway line with maximum speed of 160km/h. According to the stipulated in the first paragraph of Article 5 and Annex I of the Law on EIA, for this scenario, which includes construction of new lines for long-distance railway traffic, the EIA procedure is obligatory. Scoping Report shall include a description of possible railway line alignment alternatives, a description of significant impacts of new railway line construction on the environment, reasons for identifying these impacts and a description of mitigation measures. Of course, the project described in this scenario will have significantly stronger impact on the environment than previously described scenario track overhaul. Therefore, the experts should use all available data about the environment (its sensitivity, simple observations and results of measurements), as well as all their knowledge and practical experience to recognize the significance of environmental impacts during the railway line construction and operation.

During construction and operation of such a big infrastructure project, the most significant impacts could be expected on settlements and population, surface and ground water, use of land and spatial organization, agricultural soil, flora and fauna. The impacts on other infrastructure systems (both, existing and planned), protected nature areas and cultural and historical heritage should also be carefully examined in the following stages of the project.

The significance of some impacts can be different in different phases, so mitigation measures, where negative impacts are identified, should be defined for both, construction and operation phases of the project. For example, mitigation measures related to the air quality will probably be required during the construction of electrified railway line, but impact of an electrified railway line in operation on air quality is insignificant and it will probably not require mitigation measures. Moreover, noise and vibrations during the construction are mostly caused by construction machinery in operation; On the other hand, noise and vibrations during the railway line in operation are caused by the train movement, so the mitigation measures should be addressed properly.

## 8 Conclusions

The study has been already classified as of international importance through the SEETO's / South East Europe Transport Observatory/ Core Network as a 'Route'. From the technical point of view, the short term interventions are track renewal with the improved superstructure components along the whole line and 3 station tracks, repair of tunnels (including the improvement of cross-sections in tunnels), repair of bridges (including the improvement to D4 classification, and rehabilitation of drainage and track bed), installation of electronic interlocking with the axle counters in Fushe Kosove junction, completion of the telecommunication equipment and rehabilitation of level crossings.

Although general trends in passenger traffic on Kosovo railways network indicated decrease in period 2000–2008, performance along rail Route 10 indicates gradual recovery. However, if improvements are not carried out on rail Route 10 under do–maximum option, the passenger traffic projection will stabilize over the year and potentially lose the traffic because of expected improvements in roads sector. The passenger traffic projection indicates the performance at 162.6 million pass/km and 168.2 million pass/km in 2025, and 243.3 million pass/km and 251.7 million pass/km in 2042 respectively to the options. This also indicates a relatively small difference in traffic contrasted to differences in project options and their investment costs.

Oppositely to passenger traffic, freight traffic on Kosovo railways network indicates substantial recovery in the recent years, including the performance along rail Route 10. However, the improvement options along rail Route 10 would not substantially contribute to the increase of this traffic component. This is also reflected by the fact that the freight traffic will continue to be highly dependent on development of the industries in the country, which will use the railway transport service regardless to the infrastructure improvements on railways and roads

## References

- [1] Law on Railways Railway, Kosovo Government, 2011, Prishtine. Kosovo
- [2] Law on railways safety, Kosovo Railways, /2009/, Prishtine
- [3] Law on spatial arrangement and construction.
- [4] Rulebook on insulated rail joints in superstructure of the railway lines (Rulebook no. 312).
- [5] Rulebook on superstructure maintenance of railway lines (Rulebook no. 314).



## 4 INFRASTRUCTURE MANAGEMENT



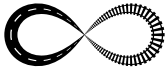

## EFFICIENT AND CUSTOMER FRIENDLY LUGGAGE LOCKING

Bernhard Rüger<sup>1</sup>, Hans–Christian Graf<sup>2</sup>, Burkhard Stadlmann<sup>2</sup>

*1 St.Pölten University of Applied Sciences & Vienna University of Technology, Austria*

*2 Upper Austria University of Applied Sciences, Austria*

### Abstract

Locking up luggage at a railway station is a basic service many passengers want to use. Especially when they try to use their time efficiently, like for shopping, for meetings, or for sightseeing, luggage often accommodates. Most of today's luggage lockers do not fulfil the needs of modern travellers. This paper gives an overview of all the passengers needs and expectations with regards to station luggage storage and benefits for station operators who offer suitable and accepted storage systems.

*Keywords: luggage, lockers, customer friendliness, accessibility*

### 1 Introduction

Long distance travellers, travelling by train, usually carry a lot of luggage. Depending on the travel purpose, the configuration of luggage items will vary, but on average every passenger has got one piece of hand luggage and every other passenger has an additional second piece of luggage.

There are many reasons why offering the possibility of locking up luggage at the station is meaningful and required. Business travellers, for example, may lock up their luggage during meetings, or tourists may want to use their waiting time for sightseeing. However, one reason which is interesting for both railway station operators and passengers alike is the waiting time at the station until the train departs.

Aircraft passengers are used to duty free and shopping areas in order to pass their time until departure. Modern railway stations are also turning more and more into shopping malls, offering train passengers the possibility of 'using' the time before departure by shopping, eating, drinking, etc. The big difference between services offered at airports and at train stations is that aircraft passengers already have checked in their luggage and are therefore able to go on a shopping tour without being handicapped by their belongings. Train passengers, however, always have to carry their whole luggage with them, which leads to the fact that passengers who arrive at the station early or who have to wait for a connecting train can hardly use all the attractions in the station.

Luggage is a big handicap because it's hardly possible to saunter with it through the narrow aisles of full shops. Passengers who have no free hands will wait outside of the shops and watch their belongings. Fig. 1 shows an example of countless passengers sitting around and waiting for departure. If passengers had no luggage they could spend their time shopping. This would lead to two advantages: (1) Waiting time is experienced as much shorter when strolling through shops instead of sitting on a bench in a cold departure hall. This would make the railway more attractive. (2) People sauntering through shops will increase the turnover of the shops.



**Figure 1** Passengers killing time while waiting for departure

These thoughts show that a customer-friendly possibility of storing luggage, even for a short time, is necessary and meaningful for passenger comfort, for the railway undertakings, and for the station operators. However, the storage possibilities offered at train stations today do not fulfil, in any way, the requirements of modern travellers. Therefore a study funded by the Austrian Research Promotion Agency (FFG) and the Austrian Federal Ministry of Transport, Innovation and Technology (BMVIT) analyses the basic passenger needs with regards to luggage storage with the aim of designing a concept for a new customer-friendly locker system. This paper focuses on the passengers' needs and expectations.

## 2 Passenger needs and expectations

### 2.1 Use of waiting time

Depending on the age and the sex of passengers the use of waiting time differs. For example, younger men more often prefer to use the time for working than women or elder people. But in general every fourth passenger prefers to go shopping or strolling through the shops. About one third prefers to sit in a bistro or restaurant to eat something. An additional third prefers sitting in a waiting area or in a lounge (compare figure 2).



**Figure 2** Activities if the waiting time is longer than 30 min (Question: 'If you had to wait for 30 min or longer at the station, which activities would you choose?')

Especially passengers who want to stroll around or go to a bistro say they feel handicapped by their luggage. In general more than one third of them feel handicapped or very handicapped. Also, every fourth passenger who wants to sit in a waiting area or who wants to work feels handicapped because of the same reason (see figure 3).

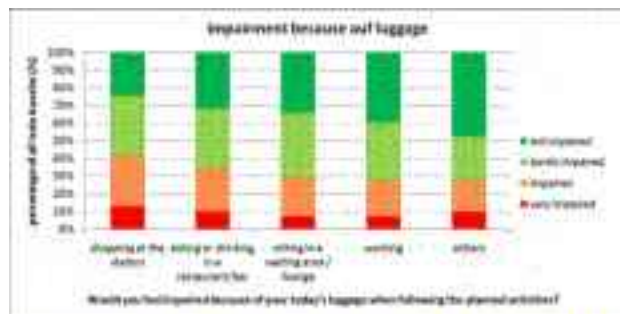

Figure 3 Percentage of all train travellers that felt impaired because of luggage while doing different activities

These numbers are an average of all passengers depending on the planned use of time. The perceived difficulties increase with the number, size and weight of luggage items. About 60% of passengers with large and heavy luggage items feel handicapped by the luggage when they want to use the time for shopping or going to a bistro or restaurant. And even 30% of passengers with medium sized luggage feel the same.

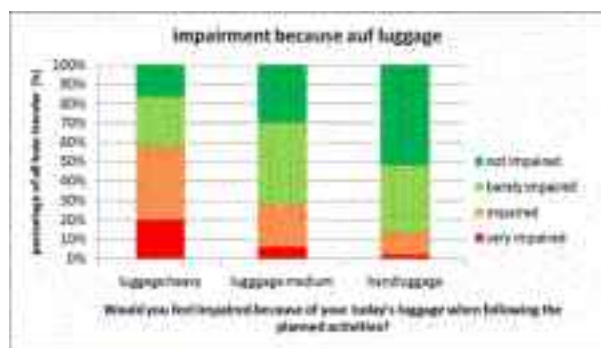

Figure 4 Percentage of all train travellers that felt impaired because of luggage weight/size while doing different activities

These figures illustrate the large number of potential consumers who want to go shopping or eat and drink but can't do that in most cases. This also points out the need and the significance of short term luggage lockers. But the offered service must be as close to the customer's needs and expectations as possible. What passengers expect under different circumstances will be pointed out below.

## 2.2 Main problems with usual lockers

Two main problems, regarding today's lockers, emerge. In general the handling of luggage is often very inconvenient and, especially for short term storage, the prices are relevant parameters of acceptance. There is no known railway stations system that offers short term storage for free or for a very low price.



## 2.3 Price

To make short term luggage storage attractive for travellers the price is one of the most important criteria. About 70% of all passengers in general name the price as an essential reason why they don't use a locker. The willingness to pay depends on the duration of storage. About one third of passengers who would like to use a locker for short term storage, to use their time at the station more pleasantly, does not want to pay for that service. More than one third is willing to pay one euro for one luggage item and hand luggage. Only one quarter is willing to pay more than one euro (see figure 5).

These research results show that, if station operators want to have as many shopping passengers as possible, short term storage up to two hours should be offered for free. The maximum acceptable amount is one euro. But it must not be forgotten that the deciding factor whether people will actually use the service or not will boil down to that one euro they would have to pay. So even if two thirds of passengers inquired say they are willing to pay one euro, many won't do so in reality.

It seems best to offer short term storage for free while taking into account that the lockers will pay off indirectly: since the number of passengers who will use the retail possibilities will greatly increase, the turnover and the profit will rise.



**Figure 5** Willingness to pay for short term storage (Question: 'How much are you willing to pay for short term storing (up to two hours) of one big piece of luggage?')

For storage—in duration of one day passengers are willing to pay more. Only 15% are willing to pay only one euro, one third is willing to pay two euros and an additional third is willing to pay three or four euros. Since the station operator has no immediate benefits, like additional shopping passengers, a price between two and four euros seems to be acceptable (see figure 6). But of course passengers who lock up their luggage for several hours or a whole day will also come back before departure and might leave the luggage in the locker for doing some shopping at the station until departure.

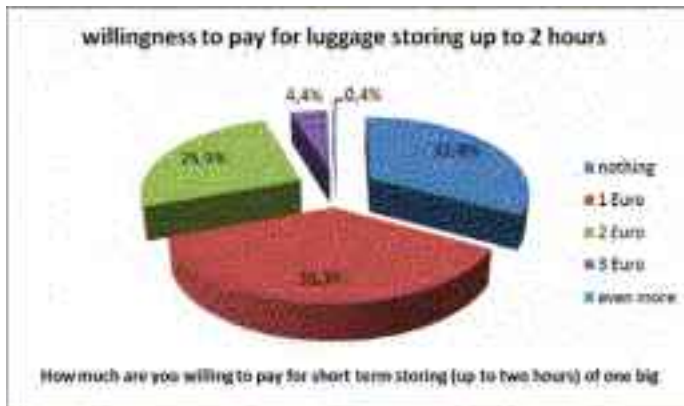

**Figure 6** Willingness to pay for one-day luggage storing (Question: 'How much are you willing to pay for one day luggage storing, for one big piece of luggage plus one piece of hand luggage?')

## 2.4 Handling

Apart from the price, the handling of luggage lockers is an essential criterion for acceptance. The handling process consists of easy locating, the potential necessity of lifting up the luggage, the size of the lockers, the immediate handling (payment process, central touch screen etc.), the time duration of the locking process and the return of the luggage.

The most important factors are the size of the lockers and the fact whether the luggage must be lifted or not. For short term storage, the time needed for the storage process is also essential, especially when passengers want to pick up their luggage in order to catch the train.

## 2.5 Required lifting of luggage

Depending on the age and sex, travellers experience difficulties when lifting their luggage. For example about 50% of all female passengers with large luggage are not able or willing to lift it, about 20% are able or willing to lift it up to about one meter and only 30% are able to lift it higher.

For about 70% of all female and 40% of all male travellers, storing luggage at floor level is important or very important. Also for 70% of all passengers above the age of 60 this is a must.



**Figure 7** Many passengers have troubles when lifting their luggage

## 2.6 Time needed

The time needed for storing and especially for retrieving the luggage is another very important criterion for acceptance. More than 25% of the asked train passengers say that luggage retrieval must not take longer than one minute, more than 50% would accept a retrieval time between one and three minutes (see figure 8). This time frame includes the whole process from arriving at the locker site to retrieving the luggage and leaving. Especially the perceived time needed when passengers are in a hurry and they are nervous because of the approaching departure of their train is very important. If passengers are in a hurry, one minute can be perceived as five minutes. For systems that may need a little bit longer – for example central locker terminals – a timer that tells the remaining time in seconds would be very meaningful.

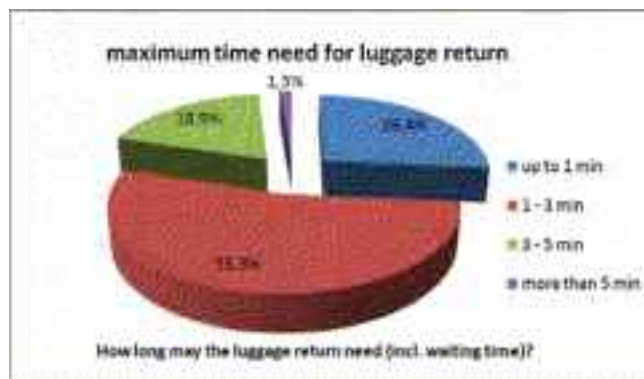

Figure 8 Maximum allowed time for luggage return (Question: 'How long should luggage return, including waiting time, last – at most?')

## 2.7 Need for space

Many of today's lockers are too small for common luggage items. The width of many lockers is 33cm, but 40% of all luggage items are bigger. That means that 40% of luggage items do not fit into normal lockers. Passengers either cannot store it or are forced to use a much more expensive locker for huge items.

## 3 Conclusions

About 80% of passengers, staying more than 30min at the station, consider using a short term locker in order to move around more easily when using the station's infrastructure like shops or bistros (see figure 9). For half of them the handling must be very quick. One third says they will use storage possibilities only if no fee is charged. Station operators are likely to benefit if they offer short term luggage storage for free since the number of potential retail customers at the station would greatly increase.

With regards to the acceptance of the system and to passenger comfort, needs, and expectations a locker system that allows floor level storage or storage at a very low height is required. The system must also serve different dimensions of today's luggage!

Therefore, many travellers would prefer central locking terminals like in Köln main station (see figure 10). But in this case the handling time is very important.

In order to fulfil all the different customer needs, an Austrian project consortium consisting of partners: Upper Austria University of Applied Sciences, the St. Pölten University of Applied Sciences and the consuler netwiss GesmbH are working on a completely new storage system

that allows customer friendly storage while being very efficient for station operators at the same time.



Figure 9 General wish of luggage locker consumers (Question: 'Would you like to store luggage for a short time, in order to use the station infrastructure more easily?')

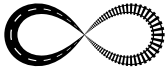

Figure 10 Central luggage terminal in Köln

## References

- [1] Rüger B, Zwischenbericht Store&Go (November 2010), ways2go–project funded by FFG





## PUBLIC BUSES ON EMERGENCY LANES – A VERY SPECIAL USE OF A MOTORWAY IN AUSTRIA

**Wolfgang Josef Berger**

*Institute for Transport Studies,*

*BOKU – University of Natural Resources and Life Sciences, Vienna, Austria*

### Abstract

Linz is the capital of the Austrian region Upper Austria and its political and economic centre; the population of the greater Linz conurbation is over 250,000. It is hardly surprising that the arterial roads leading to Linz were regularly congested at peak hours as early as the 1990s (and they still are). Not only car passengers lost time but many bus passengers also suffered, and the bus time tables became increasingly unreliable.

Given this situation, more than ten years ago the idea was borne to permit public buses the use of the emergency lane of the motorway A7 leading to the city. After years of discussion about this transport policy, many obvious reservations (e.g. those expressed by rescue services) and uncertainties (e.g. how to proceed in wintry conditions) remained. Therefore, the Austrian motorway operator ASFINAG commissioned a feasibility study. It came to the conclusion that it would be both possible and useful to open the emergency lane for public buses in case of congestion on workday mornings. In 2004 the authorities took the plunge and started a 3 km trial operation; nothing like this had ever been tried before. The practical experience gained was so positive that in consequence the measure achieved not only the 'status of regular operations' but was also extended to some additional sections of the motorway.

The paper (i) provides some key findings of the feasibility study and recommendations based on them; (ii) it describes the conditions under which the measure was implemented; and (iii) it highlights the practical experience from different points of view (bus operator, fire and rescue services, police, and road maintenance department).

*Keywords: public bus, emergency lane, motorway, temporary use, congestion*

## 1 Introduction

### 1.1 General comments regarding the special use of emergency lanes

Under normal circumstances the emergency lanes of motorways are used to temporarily park broken-down cars; in case of accidents, emergency vehicles use them; during roadwork they are used for traffic routing on multiple lanes, and they considerably facilitate maintenance work. In general, they are an important factor increasing safety; in comparison to motorway sections without an emergency lane they reduce the accident rate by about one fourth [1].

At the end of the 1990s, after the traffic volume had steadily increased which lead to more frequent congestions, Germany started to open emergency lanes of certain motorway sections temporarily for the moving traffic to increase the road capacity during rush hours [2], [3]. Initially, the emergency lanes were opened by the police with the help of manually operated hinged flap signs but nowadays sophisticated electronic control and information systems are used (traffic-actuated variable message signs, video surveillance systems, etc.). By now, the

temporary opening of an emergency lane ('rush hour lane') is quite common in Germany [4], [5], the Netherlands [6], and in the United Kingdom [7], and it is being tested in a pilot project in Switzerland [8]. Of course, this uncommon use of emergency lanes requires a legal base which means changing the road traffic laws and the introduction of new road signs. The various systems for the temporary opening of emergency lanes are designed in slightly different ways, but in general these lanes are opened for all types of vehicles.

For about one year the Austrian motorway operator ASFINAG has been discussing the possibility of a rush hour lane for a motorway section close to Vienna, but so far there is no timetable for its implementation. But there is a very special way of using the emergency lane in a part of Austria, and to the best knowledge of the author, this is actually a unique way: close to the town of Linz, the emergency lane is opened for public buses in the case of congestions during rush hours.

## 1.2 The concept of a special way of emergency lane use in the Linz area

Linz is the capital of the Austrian region Upper Austria and its political and economic centre; the population of the greater Linz conurbation is over 250,000. It is hardly surprising that the arterial roads leading to Linz were already very busy in the 1990s. Particularly the section of the motorway A7 leading to the town from the east was (and still is) regularly congested at peak hours (Figure 1).

Since up to 15 public buses use the above mentioned section of the A7 every workday morning during rush hours, not only car passengers lose time but numerous bus passengers also suffer, and the bus timetables became increasingly unreliable. For that reason, more than ten years ago the bus service operator had the idea that it would help if buses were permitted to use the emergency lane. So he suggested a project which he considered suitable to an ideas competition on how to promote mobility services. Although his project wasn't awarded he did not abandon the idea but started to present it to various traffic and political decision makers. As it often happens when somebody tries to introduce any new traffic-related measure, a long-drawn discussion about transport policy began. It revealed rather different opinions, attitudes, and arguments, which basically either supported or rejected the bus service operator's suggestion. Even years later, many obvious reservations (expressed by rescue services and others) and uncertainties (e.g. how to proceed in wintry conditions) remained.



Figure 1 Congestion on the A7 close to the exit Linz-Dornach

## 2 The Feasibility Study

The discussions about possible kinds of use of the emergency lane did not lead to any specific result. Those who supported the special use of the emergency lane were unable to achieve its implementation while those against the measure lacked arguments to kill the idea. Therefore, the Austrian motorway operator ASFINAG commissioned a feasibility study [9] to obtain objective and well-founded information (i) whether anything could be done to improve the situation, and (ii) if yes, what kind of action would lead to the most favourable result, and (iii) how to implement the respective measure.

### 2.1 The Object of Investigation

The study focused on a 5 km section of the westbound carriageway of the A7 leading to Linz. The section started at the motorway access at Treffling junction, included the Linz–Dornach junction and ended at the exit at Linz–Urfahr junction (Figure 2). From its beginning to the access Linz–Dornach the carriageway has two lanes of 3.75 m each (plus a hard strip of 1.0 m on the left) and three lanes from that access onward. On the right there is a continuous emergency lane, 3.0 metres wide. Some of the regular service buses use the motorway even before they get to Treffling junction, others access the motorway there; all of them leave the motorway at the exit Linz–Dornach; from there they access the urban road network. Several scenarios for the use of the emergency lane were investigated: (1) opening the emergency lane for regular service buses in case of congestions at peak hours; (2) opening the emergency lane for HOVs (high occupancy vehicles, i.e., with three or more occupants) at peak hours; (3) marking a particularly long deceleration lane (max. 2.6 km) ahead of the exit Linz–Dornach.

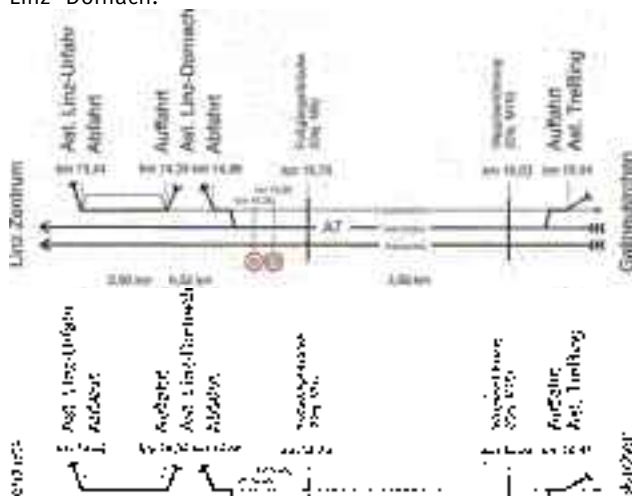

Figure 2 System diagram of the section in question

### 2.2 Methods used

Various methods were used as part of the survey:

- Traffic counts: manual counts during morning peak hours were used to complement already available data about the traffic volume.
- Accident analysis: the accident rate (personal injury accidents only) during the previous five years was analyzed in detail for both carriageways of the A7.



- Survey of bus drivers: bus drivers were asked to record their arrival time at the first bus stop after leaving the motorway at the exit Linz–Dornach for two weeks. These arrival times were compared to the scheduled time according to the time tables.
- Survey of the degree of occupancy: during morning peak hours the number of occupants per car on the A7 was counted, the number of occupants per bus was estimated.
- Calculation of the travel time: At two points at the A7 (down from the bridge above the motorway at km 18.0 and at a short distance ahead of the exit Linz–Dornach at km 15.1) video recordings were made; the number plates of vehicles were recorded manually and the travel time during morning peak hours was calculated.
- Support by a group of experts: the experience of a group of experts – members were representatives of the local transport authority, the motorway operator, the bus operator, the police force, rescue services, and the fire brigade – was taken into account. Throughout the project, intermediate results were discussed and the next steps planned.

### 2.3 Results (Examples)

The following detailed results of the study are only part of the overall findings.

The average daily traffic volume on the motorway section included in the survey was below 30,000 veh/24h and hardly surpassed 3,000 veh/h even during peak hours. This means that the traffic volume is significantly below the capacity of the cross section. The frequent congestions during morning rush hours are therefore due to bottlenecks further downstream in the urban area (there the ADT increases to above 100,000 veh/24h).

The accident rate on working days was quite typical for a motorway section with regular tailbacks during morning rush hours. The number of accidents was above average (0.71 accidents/km per year) but they were comparatively harmless (22 of the 23 injured people suffered only slight injuries). Three quarters of the accidents occurred in the time from 6:00 a.m. to 9:00 a.m., and 10 of 11 were rear end accidents.

The survey of the bus drivers showed delays particularly on Mondays and Thursdays with buses being 20 or more minutes late compared to their timetables (Fig. 3).

The car occupancy during morning rush hours is shown in Figure 4. On average, the car occupancy rate was 1.32 people per car; 75% of the cars had only one occupant, i.e. the driver, 20.5% had two and 4.5% had three or more occupants. In the case of buses, 10 were considered fully occupied (70 passengers each) and 3 half occupied (25 passengers each). This means an average number of 60 passengers per bus.

Measuring the travel time on a Monday morning showed that due to congestions between about 6:45 a.m. to shortly before 8:00 a.m. more time was needed for the same distance (Figure 5). It was a mere coincidence that the tailback on this particular day reached the first cross section used for measurements. Compared to a trip during an inter-peak period and when observing the speed limits on the 2.8 km long measuring section, the loss of time amounts to a maximum of 8 minutes (the one obvious exception, the 'fast' car at 7:17 a.m., was a police car on the emergency lane). The average time loss per vehicle per congestion was 3.59 minutes. Ten regular service buses were affected; one of them (the one at 7:00 a.m.) illegally used the emergency lane for about 1 km and thus managed to avoid the congestion. For bus passengers, a total time loss of about 36 person hours per congestion was calculated; on the assumption of 75 of these events per year this would amount to a total of 2700 person hours.



Figure 3 Late running of the public buses after leaving the A7 at Linz–Dornach, based on the recordings of the bus drivers

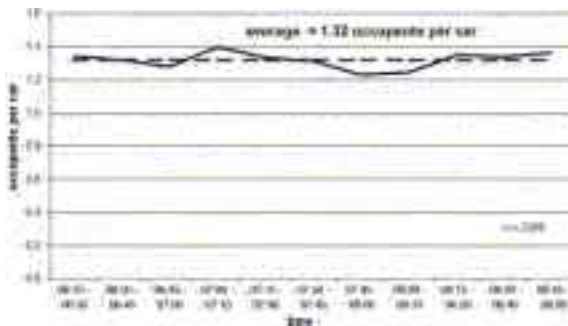

Figure 4 Car occupancy on the A7 (Monday, 6:15 to 9:00 a.m.)

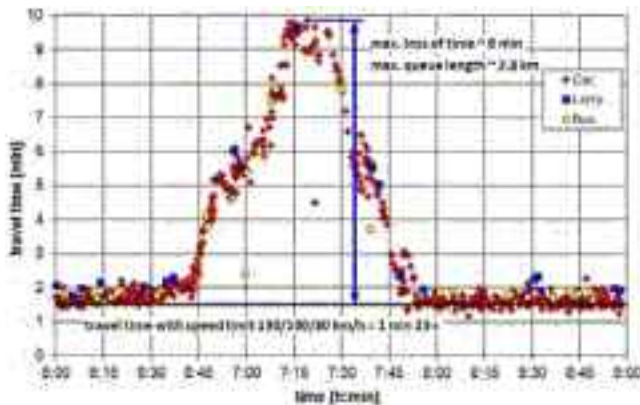

Figure 5 Travel times on the A7, from km 17,9 to 15,1 (Monday, 6:00 to 9:00 a.m.)

## 2.4 Recommendations

Taking the experience of the group of experts into account, the feasibility study resulted in the following conclusions and recommendations.

Opening the emergency lane for HOVs does not seem recommendable. Important arguments against this approach include the difficulty of signalling (no suitable traffic signs are available), the expected problems in the weaving sections of the Linz–Dornach junction, the concern that emergency vehicles might be obstructed in emergencies, and last but not least worries that the system might be abused since the police force has not the capacity for efficient enforcement. Particularly long deceleration lanes did not seem recommendable either. Similar arguments as those already mentioned speak against this approach. Moreover, the secondary road network would probably have to cope with more traffic caused by those car drivers who first pass congestion on the motorway and then leave it sooner than really necessary. This would be an undesirable effect.

But on certain conditions e.g. creating an emergency lane of 3.5 m by narrowing the traffic lanes and the hard strip on the left beside the lanes, it was possible to recommend the temporary opening of the emergency lane for buses. In addition to this, new signs were created to alert drivers to the fact that buses are permitted to use the emergency lane.

## 3 Implementation

The concept was implemented in September 2004, initially as a pilot project. With the exception of the widening of the emergency lane, the suggestions specified in the study were taken into account, and new information signs were erected (Figure 6). The bus operator was granted a special permit (administrative decision) to use the emergency lane of the A7 between Treffling and Linz–Dornach in case of congestion from Monday to Friday from 6:00 a.m. to 9:00 a.m. on the following conditions:

- a maximum speed of 50 km/h for buses on the emergency lane;
- driving at walking speed when moving from the emergency lane to the deceleration lane;
- no merging back into the normal traffic lane (in case the congestion is easing);
- mobile phone connection between the bus driver and the operator's control centre;
- no driving on the emergency lane in case of accident, road work, or a broken down vehicle there.

This approach proved such a success that in 2006 the concept was also implemented for the opposite carriageway of the A7. This section of the motorway ends about 10 km northeast of Treffling junction; at times when commuters drive home, the last few kilometres were frequently congested. To ease the congestion, buses were permitted to pass congestions from Monday to Thursday from 4:00 p.m. to 7:00 p.m. and on Fridays from 12:00 noon to 7:00 p.m. Since 2010 buses driving in the direction of Linz have been permitted to move onto the emergency lane even before they reach Treffling junction – i.e. prior to the respective exit or access – if the tail of the morning congestion reaches that far back.



**Figure 6** Road signs to indicate that regular service buses are permitted to use the emergency lane (text on the left: emergency lane ... Mon.-Fri. 6:00-9:00 a.m. ... only for public buses to exit Dornach (text at the bottom in Czech) text on the right: Watch for buses!)

## 4 Experiences

In numerous personal discussions with representatives of the various organisations involved, in autumn 2011 the author gathered information about the practical experience with the scheme.

**The bus operator:** buses use the emergency lane virtually every day. Of course, bus drivers have to adjust their speed to road, traffic, and weather conditions, respectively, so there have never been any problems. Even if there is some obstacle on the emergency lane – which happens only rarely – merging back into the normal, congested traffic lane is no trouble. Buses run far more reliably and the number of passengers has increased considerably on the lines in question. Obviously a number of commuters have decided to abandon their cars for a bus. The overall verdict: 'We can't imagine operating without this option!'

**The police:** so far, no accidents have been reported in connection with the use of the emergency lane by buses. Occasionally it happened that (foreign) coaches used the emergency lane which is not permitted. The misuse of the emergency lane by car drivers seems to be limited or at least not worse than before the opening of the emergency lane for buses. Policemen in unmarked cars are mainly responsible for the supervision.

**Rescue services and fire brigades:** None of the emergency services operations were ever hindered by or encountered problems due to buses using the emergency lane.

**The highway maintenance unit:** over the phone we keep in contact with the bus operator. For example, in case of heavy snowfall the buses may only use the emergency lane after we have cleared away the snow. We use slightly more road salt now because clearing the emergency lane has a higher priority than it had in the past. We only cut the green at times when buses are not permitted to use the emergency lane, but that is no problem.

## 5 Conclusions

The permission for regular service buses to use the emergency lane to avoid congestions on the motorway proved such a successful promotion of bus traffic that this scheme has achieved 'status of regular operations' on the A7. Once more it was proved that a good idea combined with a thorough preparation can lead to cheap but nevertheless highly practical traffic solutions. A certain degree of persistence, tenacity, and persuasiveness of those people who have a good idea are necessary. As in this particular case, a certain degree of courage of the competent authorities to give such an idea the chance to prove its practicability is also required.

## 6 Most recent development

Since 1st January 2012 a new Austrian law requires drivers to clear a path for emergency vehicles. In case of congestion all vehicles on the left lane are required to move to the far left and may use the hard strip on the outer left. Vehicles on the right lane are requested to move to the far right and use the emergency lane as far as necessary. Some representatives of public authorities held the opinion that because of the new law buses should be forbidden to use the emergency lane regularly, because there would no longer be sufficient space for them and it would be too dangerous. In December 2011, the whole successful project seemed suddenly endangered. At the last minute an agreement was reached: buses are still permitted to use the emergency lane but they have to reduce their maximum speed from 50 to 30 km/h. The experience of the first six weeks clearly supports the promoters of the scheme: it still works.

## References

- [1] Heidemann, D., Bäumer, M., Hamacher, R. & Hautzinger, H.: Standstreifen und Verkehrssicherheit auf BAB; Statistische Analyse. Berichte der Bundesanstalt für Straßenwesen, Verkehrstechnik, Heft V 55, Bergisch Gladbach 1998.
- [2] Kellermann, G., Bohlander, F., Dewes, U., Jansen, C., Lehmann, R., Rohloff, M. & Stüben, G.: Erfahrungen zur verkehrabhängigen Seitenstreifennutzung. Straßenverkehrstechnik 46 (12), pp. 637-642, 2002.
- [3] Lemke K.: Temporäre Umnutzung von Seitenstreifen an Autobahnen. Straßenverkehrstechnik 47 (8), pp. 409-413, 2003.
- [4] Riegelhuth, G. & Pilz, A.: Temporary Hard Shoulder Use in Hessen – Experiences and Strategic Planning. iztern, Aalborg, Denmark, June 2007.
- [5] Lemke, K.: Standstreifenfreigabe – Sicherheitswirkung von Umnutzungsmaßnahmen. Berichte der Bundesanstalt für Straßenwesen, Verkehrstechnik – Heft V153, 2007.
- [6] Veld in 't, R.: Monitoring of the main effects of rush hour lanes in the Netherlands. European Transport Conference, Leeuwenhorst, Oct. 2009.
- [7] MacDonald, M.: M42 ATM Monitoring and Evaluation. Project Summary Report, Highways Agency, 2009.
- [8] Maillard, P.: Temporäre Nutzung der Pannestreifen – Pilotversuch in der Schweiz. Presentation on the 24th D-A-CH Information Session (FGSV – FSV – VSS), Cologne, Nov. 2011.
- [9] Berger, W. J., Hössinger, R. & Meth, D.: Machbarkeitsstudie für die Mitbenutzung des Abstellstreifens der A7 Mühlkreisautobahn zwischen Treffling und Dornach. Institut für Verkehrswesen, Bericht Nr. 01/2004, Universität für Bodenkultur Wien, 2004 (unpublished).

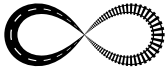

## THE POLISH SCIENTIFIC RESEARCHES ON ELECTRONIC TOLL COLLECTION AREA

**Gabriel Nowacki**

*Motor Transport Institute, Poland*

### Abstract

This article presents tests results of the pilot project – The functional structure of the National Automated Toll Collection System (NATCS). During the tests OBU automatically charged a fee (toll), taking into account the category of vehicle (admissible mass, the number of axes), the category of emissions, and distance of road travelled. OBU is equipped with GPS, GSM and Dedicated Short Range Communication (DSRC) modules, which ensure its interoperability with other European Electronic Tolling Systems (EETS) in the EU Member States. The system meets the requirements of 2004/52/EC Directive and the EC Decision from the 6<sup>th</sup> of October 2009. Tests proved high effectiveness of automatic number plate recognition, being 99,9%. The analyses of PDOP (Position Dilution of Precision) parameters showed that 90% had the value below 1, and 8% value from 1 to 3. Based on tests, the maximum number of satellites for localization was – 11 and minimum – 5, that create value 99%.

*Keywords: EETS, NATCS, DSRC, interoperability.*

### 1 Introduction

There are two different types of European Electronic Tolling Service (EETS): Dedicated Short Range Communication (DSRC) and GPS/GSM based systems.

In most EU countries (Austria, France, Spain and Italy) DSRC type systems of electronic tolling are used, that rely on dedicated short range radio (microwave frequency - 5.8 GHz).

The OBU on-board device, operating in the DSRC system is small (size similar to a packet of cigarettes). It is mounted on the windscreen inside the vehicle. However, the device is not very smart, very simple and only performs validation functions (read only), it has no display, and cannot receive or transmit any message. The DSRC system requires a well developed road infrastructure, at every crossroads, and gates must be installed at entrances to and exists from toll road sections. In addition, data transmission is done using wired communications, and then it can take place over the Internet. The DSRC system will not be able to be incorporated into an integrated technology platform, as it will not even be able to collaborate with other national transport systems. Even in the case of the DSRC system, which is provided by Kapsch, each country has a different type of OBU device.

Another solution is to apply GSM or GPS systems. In this system, thanks to the GPS satellite positioning virtual control and tolling points established, the system can operate without the use of control gates. Data are transferred to the system directly from the OBU devices, using GSM communications.

According to the European Commission electronic tolling systems used in the European Union are not interoperable for the following reasons: differences in the concepts of tolling, technology standards, classifications, rates, discrepancies in the interpretation of laws.

The European Commission has taken two mile steps in this regard. The first was Directive 2004/52/EC of 29 April 2004 on the interoperability of electronic road toll systems in the Community [1]. Then there was the decision of the European Commission of 6 October 2009 on definition of the European Electronic Toll Service (EETS), and system architecture [2]. According to the European Commission decision 2009/750/EC, European Electronic Toll Service (EETS) should enable road users to easily pay tolls throughout the whole European Union (EU) thanks to one subscription contract with one Toll Service Provider and one single on-board unit (OBU). The mentioned decision was supported by standard EN ISO 12855 (CEN, Brussels, 05.02.2010) – tolling interoperability aims at enabling a vehicle to driver trough various Toll Domains while having only one OBU operating under contract with Toll Service Provider [3]. Implementation of interoperability is a long-term and precise action. What comes to the fore in the implementation strategy for interoperability is the need for introduction of the EETS system, consisting of the following systems: DSRC, GSM, GNSS1. GNSS – Global Navigation Satellite System. GNSS-1 is based on existing segments of the orbit Navstar GPS and Russian GLONASS system. An integral part of the GNSS-1 is a system of differential (DGPS - Differential Global Positioning System). Development of GNSS-1 will be the GNSS-2. The constellation of navigation satellites will include the GPS Navstar satellites of II F type GLONASS M and new European satellites wit working name of Galileo.

The best universal solution in complicated situation in UE is implementation of hybrid system (includes: DSRC, GSM, GPS technology), the researches developed in Czech Republic, NATCS is mentioned type of system.

## 2 Researches characterisation of NATCS

### 2.1 Test structure of NATCS

The research team identified KSAPO's functional structure, which consists of the following elements:

- Intelligent on-board device called TRIPON-EU, which was installed in test vehicles,
- OBU device installation system using a chip card,
- two control gates (with DSRC modem and a vision tolling system),
- laboratory model of national Centre for automatic tolling KCAPO,
- a proxy server for data exchange between headquarters and the OBU system via GPRS,
- control centre to manage the OBU devices allowing for management of OBU and analyses of data relating to the collection of tolls,
- analytical tools for DSRC, image analysis and classification of vehicles.

The onboard device TRIPON-EU (Fig. 1) is available in two different versions. The test system used the version mounted in a single casing collecting all components, including GPS and GSM antennas. This version is designed for installation on the windscreen of the vehicle.



Figure 1 An onboard OBU device and its mounting brackets [4]

The OBU device should store the following data: vehicle class, vehicle weight, axles or class of emission, registration numbers and contractual details. Data can be entered into the device using a chip card.

The GPS module used in OBU devices supports computing navigation (DR, dead reckoning) to improve the accuracy of positioning.

GPS data (from satellites), supplemented by the results of computing navigation are used as input for detection of on-ground facilities. Detected events are logged in the event file. The European EGNOS system can be enabled or disabled through the configuration file activated at the time of start-up. The device is designed to cooperate with Galileo.

Data recorded by the OBU onboard unit are transmitted to the internal components of the EETS system, using GPRS technology (packet data transmission system used in GSM technology). The data transmission between the mobile onboard units and the internal elements of the system takes place via a proxy server, which operates completely independently of the billing and accounting system. Data is transferred in batches, which means that one does not need to maintain a permanent connection between onboard devices and the internal components of the system. This is one of the biggest advantages of the concept of smart clients. GPRS allows for even greater reduction of communications costs.

Tripon EU independently analyses the data (GPS location data, vehicle defined data, data on tariffs – fixed schedule of fees and other data) that are remotely transmitted, in real time, to the server. Data about events related to billing, and events relating the control and supervision, are limited to a minimum, which significantly increases the throughput of the system and reduces the operating costs.

Depending on the required precision and an additional control, Tripon EU can operate in two positioning modes: using signals from GPS and assisted by a signal trace from other onboard equipment. In order to verify system capabilities in both vehicles OBU devices were checked using only the GPS signal and in conjunction with an additional device, from which passage signal was received. The comparison indicated a small discrepancy between the satellite positioning signal and the passage signal, indicating these by 'Delta Tacho +x%' messages. On-board equipment TRIPON-EU uses built-in GSM antennas, there is no need for external antennas. The SIM card installed inside cannot be replaced by the user. For the convenience of testing, using the s button (send) one may activate a GPRS communication session at any time without having to wait for the next automatically initiated session. The onboard device TRIPON-EU can receive short text messages.

The device board TRIPON - EU is equipped with a DSRC module (5.8 GHz, 1R) DSRC (Dedicated Short-Range Communications). In cross-border traffic OBU device enables collaboration with GPS/GSM tolling systems (Germany, Slovakia) or DSRC systems used in other countries (Austria, Czech Republic, Italy, Spain, France). The basic standard used in these types of systems (DSRC) is the ISO EN 15509 standard (Media Transactions). The onboard unit TRIPON - EU makes use of such transactions in order to illustrate the possibility of tolling in cooperation with the vision system – ANPR.

## 2.2 Tests results of NATCS

Tests of the NATCS system, including control of OBU devices, tolling segments at selected sections of roads as well as control gates were conducted in July and August, while vehicles passing through the control gates were registered from 1st July to 30th November 2010. The tests of the system were conducted by Motor Transport Institute, FELA Management AG and Autoguard SA. The architecture of the system is in conformity with Directive 2004/52/EC and decision of the European Commission of 6th November 2009 as well as the CE and ISO standards.

During the test four OBU Tripon EU units were examined, whose task was to detect all events associated with the collection of toll directly in OBU, as well as in the log file and display them on the screen. OBU is also meant to send log files to the proxy server and receive data from the



server (data, status information and software updates.) For testing purposes four vehicles were added to the database

Out of the several proposed test route options we chose the Płońsk–Garwolin, Garwolin – Płońsk route, as the most diverse one that allows for checking the greatest number of elements of the system, including in the immediate vicinity of the route the both control gates and allowing the use of as many as three actual segments of expressways:

- two segments of expressway S7,
- one segment of expressway S17,
- two segments of National Roads.

On the basis of recorded data, transmitted by the vehicle in the form of messages, it was possible to recreate the exact route of the vehicle with the OBU device.

One of the most important parameters determining the accuracy of measurement and transmitted in location messages is PDOP (Position Dilution of Precision) – defect in determination of position precision. PDOP is a coefficient describing the relationship between the error of user's position and the error of satellite position.

The value of any of the parameters equal to 0 means that at any given time measurement of position is impossible due to interference, weak signals from the satellites, too few visible satellites, etc. The smaller the value of this parameter (but greater than zero), the more accurate is the measurement. The following descriptions signal quality depending on the value of PDOP are assumed: 1 (perfect), 2–3 (excellent), 4–6 (good), 7–8 (moderate), 9–20 (poor), > 20 (bad). The data of the PDOP parameter obtained in the tests was presented on Fig. 2. The horizontal axis (x) depicts are values for PDOP. The vertical axis (y) depicts the number of measurements (in percentages) during which a given value of PDOP was obtained. The stats were calculated based on 4627 measurements of position.

Average value of PDOP for all OBU was 90 % of perfect and 8% excellent values. Analysis of the measurement data of the PDOP parameter and the number of satellites used during the test showed that 90% of the PDOP measurements were lower than 1, which should provide accuracy of location accuracy with error of no more than 6 meters.

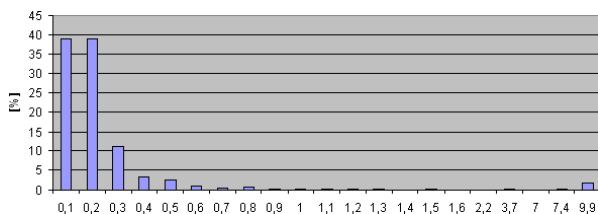

Figure 2 Results of PDOP

The number of satellites used for measurements of all OBU devices is presented in Fig. 3. For purposes of KSAPO it was assumed that GPS receiver in OBU should track at least 5 satellites, for more accurate calculations and in the event of loss of signal from one of them.

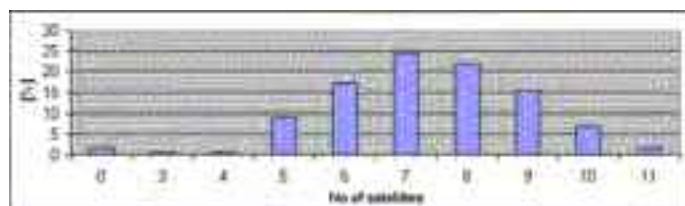

Figure 3 Number of used satellites for localization

The presented data shows that the maximum number of satellites used in for the purpose of location was 11, and in the case of 99% of measurements at least 5 satellites were used (the detailed results of satellites: 5 – 10%, 6 – 17%, 7 – 25%, 8 – 22%, 9 – 16%, 10 – 7%, 11 – 2%). As part of the project two DSRC gates with tolling system were prepared. This has allowed for testing of the following functions:

- operation of DSRC microwave devices
- operation of visual system ANPR system (automatic number plate recognition).

From 1<sup>st</sup> July to 30<sup>th</sup> November 2010, 2964 vehicles passing through control gates were registered in the database of the system. Not all vehicles were equipped with OBU.

During the tests at the ITS Demo and Autoguard Demo gates, using the DSRC system, passage of 24 test vehicles was recorded. During the tests at the ITS Demo gate as many as 667 photographs of passing vehicles were taken.

During the tests at the Autoguard Demo gate 2297 photographs of passing vehicles were taken. Example of the vehicle photo is presented in Fig. 4.

The registered vehicle was equipped with a French made OBU device – Passango (DSRC). It was fully identified in the system as a user, which means that the KSAPO system is interoperable and can work with both, systems of DSRC type as well as GPS / GSM systems.

During each and every passage the operation of control gates as well as the conformity of the DSRC data with the ANPR (automatic number plate recognition) reading was verified. For the purpose of the second stage the onboard OBU devices were replaced with new ones. Due to a mistake the devices were wrongly installed, however the system immediately discovered the error.

Also the operation of the control gates was tested – mainly with respect to the detection of various vehicle speeds. Thanks to this, it was possible to adjust the software and then to check the newly replaced onboard OBU devices with respect to the correctness of detection of vehicles coming up to the control gate at especially small selected speeds. The system detects vehicles travelling at speeds of 1 to 200 km/h.

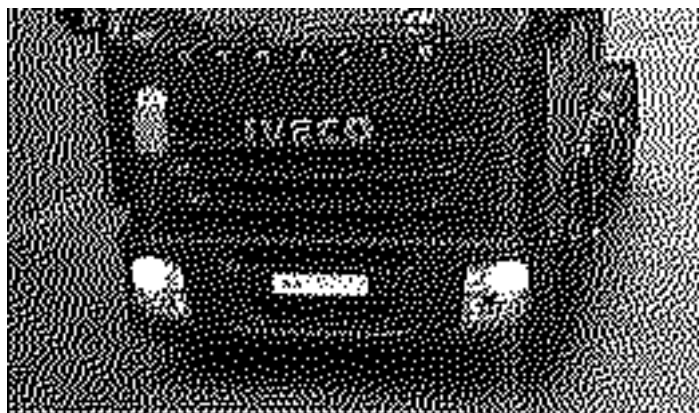

Figure 4 Picture of WWY 07512, PTM, 5 Przemysłowa Street, 07–200 Wyszaków

Legend: Date (ANPR): 28.09.2010 09:25:53; Reg. no. (ANPR): WWY 07512; Accuracy: 0.980; Gate ID: 3; Gate name: Autoguard Demo; Date (DSRC): 28.09.2010 09:25:54; Country code: F (France), Registration number (DSRC): WWY 07512; Context data: WWY 07512; OB ID: 1103467888; Vehicle ID: 2147483647; Emission class: 1; Vehicle class: 1; Vehicle weight: 18000; Total weight: 40000; Number of axles: 5; Means of payment: 2147483647.

In addition to test the drives and the checking of the functionality of the, the efficacy of the gates was checked, recording all vehicles passing at the premises of Motor Transport Institute

and at the premises of the AutoGuard company in various weather conditions and at various times of day. The efficacy of automatic detection of number plates was 99,9%. All the segments were identified correctly by the onboard devices, and there were no problems in this respect. Each segment consisted of three points, and in order for each one of them to count, all three segments had to be detected by the OBU device. As a result of this drivers who will cut through toll roads, or only pass through them, will not be registered in the system. The tests were successful and confirmed the efficacy of the selected solutions in accordance with the assumptions of the project.

### 3 Conclusions

During the test of NATCS phase, from 1<sup>st</sup> July till 30<sup>th</sup> November 2010, 2964 vehicles passing through control gates were registered in the database of the system. In addition to testing the drives and checking the functionality, the efficacy of the gates was checked, recording all vehicles passing at the premises of Motor Transport Institute and at the premises of the AutoGuard company in various weather conditions and at various times of day.

The functional structure of NATCS is according to directive 2004/52/EC, decision of European Commission from 6<sup>th</sup> October 2009 and CEN standards. The efficacy of automatic detection of number plates was 98%, and thanks to proceeding data by analyze stand, the efficacy of the system increases to 99.9%. Analysis of the measurement data of the PDOP parameter and the number of satellites used during the test showed that 90% of the PDOP measurements were lower than 1, and 8% had value from 1 to 3.

For the purposes of NATCS it was assumed that GPS receiver in OBU should track at least 5 satellites, for more accurate calculations and in the event of the loss of signal from one of them. Tests results showed that in the case of 99% of measurements at least 5 satellites were used for the purpose of location,

The NATCS turned out to be flexible when it comes to extending toll collection to every road category, every category of vehicle and, what's more, in terms of cost efficiency in implementation and operation. Another advantage is an absence of the need for new road infrastructure (gantries), while the operators can keep using the existing infrastructure. System works without toll booths, extra lanes, speed restrictions or complex structures along toll roads. Furthermore the system ability to support other value-added services on the same technology platform. Tests of NATCS project has been a complete success. The system uses GPS/GSM technologies, but also recognises devices such as DSRC and OBU. During tests, the system recognised four Tripon – EU OBU's, French made DSRC Passango device and a German made Toll Collect device of the GPS/GSM type, installed in a vehicle which did not participate in the test, but accidentally ran through the control gate. This implies that the NATCS system is interoperable and can cooperate with both GPS/GSM systems as well as with DSRC types of systems existing in other EU Member States.

Acknowledgement: The paper has been prepared with framework of NATCS Pilot Project, N R10 0001 04.

### References

- [1] Directive 2004/52/EC of the European Parliament and of the Council of 29 April 2004 on the interoperability of electronic road toll systems in the Community. OJ of the EU, L 166/132, 30.04.2004.
- [2] Commission Decision of 6 October 2009 on the definition of the European Electronic Toll Service and its technical elements. Official Journal of the European Union L 268/11, 13.10.2009.
- [3] Standard EN ISO 12855. ETC. Information Exchange between Toll Provider and Toll Operator. 2010.
- [4] Kallweit T. 2010. Technical Trial of ETC in Poland. Fela Management AG. Diessenhofen. 03/09/2010.

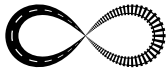

## THE FIRST EXPERIENCE OF ETC USAGE IN THE SILESIA REGION

Aleksander Śladkowski, Grzegorz Twardoch  
*Silesian University of Technology, Poland*

### Abstract

Silesian industrial region is one of the most developed areas of Poland. The main power of the coal, metallurgy, machinery, car-building and other industries is concentrated in this region. Obviously, the transport problems of the region are key issues, since delivery of raw material and finished products is conducted from the region to many European countries. Beginning 1<sup>st</sup> of July 2011 Poland is, step by step, entering the system of electronic record-keeping for the payment of the transport tax. For this purpose, the vignette system is replaced with the ETC (Electronic toll collection) system and, in particular, with the viaTOLL.

Questions relating the implementation problems of this system are being considered. The stages of its implementation are also being studied. Since the Silesian region, in the matter of system implementation, is the leading region in Poland, it is already possible to evaluate the strengths and weaknesses of the system. The impact of tax policy on the environment is also considered. The feasibility of car parks update is being discussed on an example of a specific transport company. Also, a comparison with German and Benelux countries experience is carried out.

### 1 Introduction

On 1st of July 2011 the territory of Poland was to introduced with a new automated system for collecting vehicle tax from road freight transport and buses. Some of its deficiencies resulted in the fact that its actual putting into operation took place on 3rd of June, for which its developer, known Austrian company Kapsch will have to pay a penalty of almost 7,5 million zloty [1]. According to the data, 1560 km of road was put into operation and is now served by the viaTOLL system.

Initially it was planned [2] that the viaTOLL system will be introduced in four stages:

- Stage 1 – From 01.07.2011 the new system will cover 649 km of motorways, 554 km of expressways and approximately 370 km of national roads,
- Stage 2 – In January 2012 in the system 150 km of motorways and expressways will be included,
- Stage 3 – In January 2013 the system will include the next 970 km of motorways, express roads and some national roads,
- Step 4 – In January 2014 the system will include the next 200 km of motorways, express roads and some national roads.

Fig. 1 shows a road map of Poland [3], which was to be introduced with the electronic collection of transport charges. As is seen, most of these roads are located in the southern part of Poland, with the highest density of roads falling on the Upper Silesia.

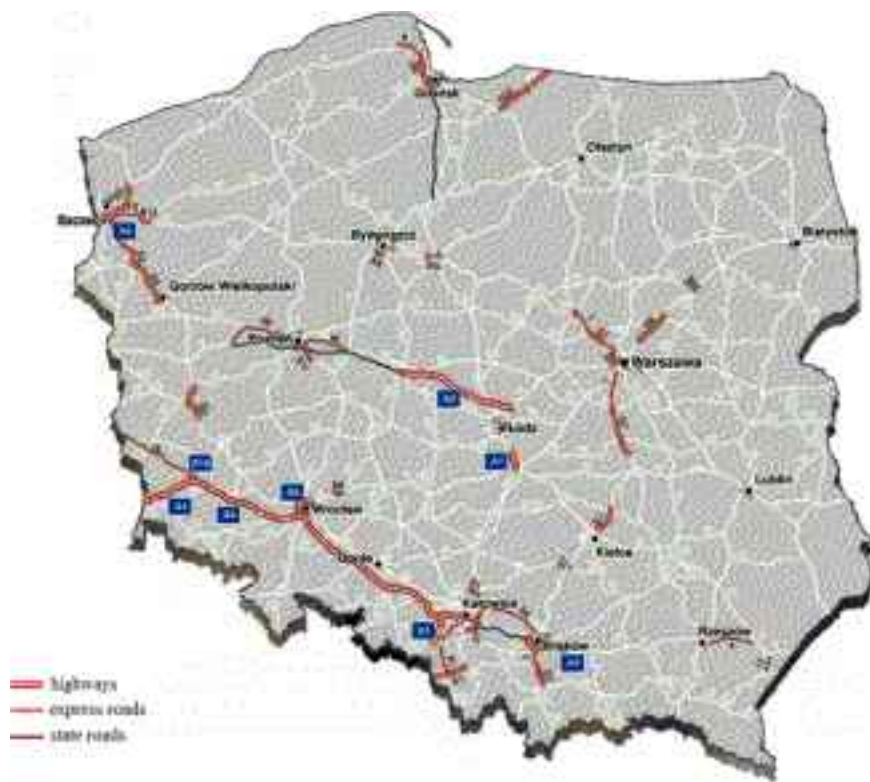

Figure 1 Map of Poland with the specified sites of toll roads

Note that Poland is not an exception in this case, and is also not the first country in Europe where the same or a similar system has been introduced. In particular, Germany is using the Toll Collect system, Austria GO system, Myto cz system is implemented in Czech Republic, Myto sk system in Slovakia, Telepass and ViaCard systems in Italy, TIS-PL system in France, Via T system in Spain and the LSWA system in Switzerland. In addition, a number of European countries use the opportunity to pay road tolls using electronic cards – DKV Card. The task of the authors did not include discussion on the advantages or disadvantages of one or the other system of electronic payments, as well as its design features. The main principles of work and organizational design are available on the viaTOLL official website [3]. Authors of this paper were interested, what specific effects will the introduction of this system bring to the transport operations in this specific region of Poland.

## 2 Upper Silesia transport situation

Payment changes, in connection with the introduction of viaTOLL for Silesian Economic Area, will have the greatest value in comparison with other regions of Poland. Upper Silesia is the most industrialized region of Poland. The majority of metallurgical and mining enterprises is concentrated in that region. Here, industries such as heavy and transport machinery, chemical and production of building materials are developed. All of this contributes to the development of road transport. Also, the densest road network is here, but the intensity of transport has its negative effects. In particular, road transport has a negative impact on the environment. This is due to different emissions in the form of exhaust gases, oil or dust waste. The situation with the recycling of outdated vehicles is still far from ideal and that also helps to increase

the number of motor vehicles waste. Noise and vibration in the neighborhood of intense highways is also a negative aspect that should be taken into account.

For road noise risk assessment the main value shall be automotive pressure ratio  $Z_m$ . Automotive pressure ratio is the product of the road length in the considered area and the average traffic in the roads network per unit area. In Poland this ratio varies from 1,0 for the Podlasie province to 5,5 for the Silesia province (Fig. 2 was developed based on [4]).

The introduction of a new payment system should stimulate the purchase of new cars that would have reduced emissions, noise, etc. On the other hand, the increase in fees will lead to an increase in budget revenues, which can and should be directed to the building of new roads, with better road surfaces, equipped with noise protection screens, etc. Thus, improving the payment system should promote the development of road transport and transport infrastructure in terms of their improvements and complement with world standards.

This trend is clearly visible in the new system of payments, if any, compared with the old vignette system, which functioned in Poland before the 01.07.2011. For example, a vignette on the annual operation of cars and trucks with a mass exceeding 12 tones and having at least 4 axes, in the previous system would cost an owner of a transport company 3371 PLN for vehicles with EURO3 standard or 2782 PLN for vehicles with EURO4 standard. Thus, if we take the norm EURO3 as a base, the savings for the owner are 17,5% without taking into account the annual mileage. It is obvious that the difference in 589 PLN was not significant and did not substantially contribute to stimulate the users in buying a new car.

Adopted rules now require payment for the car of the same class, when driving on motorways and express roads, of 0,37 PLN per 1 km for the EURO3 norm and 0,29 PLN per 1 km mileage for the EURO4 norm. The difference of 21,6% is not that important, as is the fact that this difference becomes significant for intensive use of the vehicle when the car has a significant annual mileage. If we compare the standards EURO3 and EURO5, the difference will be even more significant – 43,2%. The direction of input changes, which should significantly contribute in the improvement of the ecological situation on the Polish roads, as well as promote the development of a motorway and expresswax network, becomes apparent.

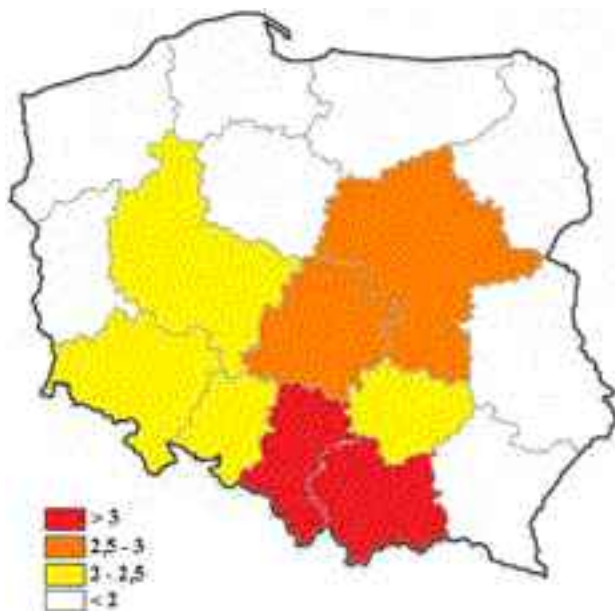

Figure 2 Automotive pressure ratio for Poland, divided into province

### 3 Effect of the new payment system on individual transport companies

As an example, a small transport company Intertransport, located in Upper Silesia in Ruda Śląska has been chosen. This company has been operating in the transportation services market since 1989, transporting various goods between EU countries. The company has three trucks with semitrailers available for the performance of transport. They are Mercedes models of different production years, relatively new (older vehicle Mercedes Actros is from the year 2002). These vehicles, in accordance with the year of production, belong to different environmental classes (from EURO<sub>3</sub> to EURO<sub>5</sub>).

In Table 1, examples of travel of two vehicles belonging to the environmental classes EURO<sub>3</sub> (Mercedes Actros 1840 number SL17055) and EURO<sub>5</sub> (Mercedes Axor 1843 number SL56367) were shown, in the duration of one month. Only journeys through Poland were indicated. The mileage on paid and free roads is analyzed.

**Table 1** An example of operation of cars on Polish territory

1	2	3	4	5	6	7	8
SL56367	Łaziska Górze	Olzszyna - granica PL/D	2010-01-11	393,83	361,76	32,07	91,9 %
	Moerdijk	Raciszyn	2010-01-14	519,26	263,54	255,72	50,8 %
SL56367	Łaziska Górze	Duisburg	2010-01-20	393,83	361,76	32,07	91,9 %
	Nieuwdoorp	Raciszyn	2010-01-22	519,26	263,54	255,72	50,8 %
SL56367	Łaziska Górze	Duisburg	2010-01-25	393,83	361,76	32,07	91,9 %
	Engis	Miasteczko Śląskie	2010-01-27	392,04	314,01	78,03	80,1 %
SL17055	Łaziska Górze	Duisburg	2010-01-25	393,83	361,76	32,07	91,9 %
	Engis	Miasteczko Śląskie	2010-01-27	392,04	314,01	78,03	80,1 %
SL56367	Łaziska Górze	Duisburg	2010-02-03	393,83	361,76	32,07	91,9 %
	Engis	Miasteczko Śląskie	2010-02-05	392,04	314,01	78,03	80,1 %
SL17055	Łaziska Górze	Duisburg	2010-02-03	393,83	361,76	32,07	91,9 %
	Engis	Miasteczko Śląskie	2010-02-05	392,04	314,01	78,03	80,1 %
SL17055	Łaziska Górze	La Louviere	2010-02-09	393,83	361,76	32,07	91,9 %
	Engis	Miasteczko Śląskie	2010-02-11	392,04	314,01	78,03	80,1 %
SL56367	Łaziska Górze	La Louviere	2010-02-09	393,83	361,76	32,07	91,9 %
	Engis	Miasteczko Śląskie	2010-02-11	392,04	314,01	78,03	80,1 %

1. Registration number of the vehicle; 2. Place of loading; 3. Place of unloading; 4. Date of loading; 5. Route length (km); 6. Toll sites (km); 7. Free sites (km); 8. The percentage of toll roads.

Specified vehicles were analyzed during one and a half year, from January 2010 to July 2011. In particular, road fee for the above SL17055 vehicle amounts to 5337,42 PLN. Extrapolating the data mileages for this vehicle at the same time, for example, from January 2012 until July 2013, i.e. in the viaTOLL payments system is shown in Table 2.

**Table 2** Extrapolating payments in Polish Zloty, for the SL17055 vehicle, in the viaTOLL system based on actual mileages two years earlier

Year	Month	SL17055	EURO5	Difference
2012	January	296,89	173,11	123,78
	February	890,67	519,33	371,34
	March	890,67	519,33	371,34
	April	919,64	536,34	383,3
	May	944,84	551,06	393,78
	June	1187,56	692,44	495,12
	July	919,64	536,34	383,3
	August	1232,1	718,6	513,5
	September	1068,53	623,11	445,42
	October	1223,51	714,1	509,41
	November	1215,67	704,74	510,93
	December	1626,65	949,05	677,6
2013	January	926,62	540,99	385,63
	February	926,62	540,99	385,63
	March	1272,88	742,54	530,34
	April	910,74	531,13	379,61
	May	1598,21	932,35	665,86
	June	1284,23	749,19	535,04
	July	895,89	522,4	373,49
		$\Sigma = 20231,56$	$\Sigma = 11797,14$	$\Sigma = 8434,42$

As we can see, such payment would led to an increment of 20231,56 PLN. An almost fourfold increase in payments would result in that the transport company would carry substantial losses. For comparison, in the same table data for a similar, but a vehicle of more modern date in correspondence with the EURO5 standard is shown, in which case the payment would have amounted to 8434,42 PLN.

- a Costs of road tolls for the SL17055 vehicle in the period from 01.01.2010 until 31.07.2011 totaled:
  - The purchase price for vignettes in Poland: 5337,42 PLN = 1334,36 €
  - The cost of road tolls in Germany: 18286,45 €
  - The cost of road tolls in the Benelux: 786 €
  - Total cost of tolls for the vehicle was: 20406,81 €
- b Cost of tolls, from the beginning of the viaTOLL system:
  - The cost of road tolls in Poland: 20231,56 PLN = 5057,89 €
  - The cost of road tolls in Germany: 18286,45 €
  - The cost of road tolls in the Benelux: 786 €
  - The total cost of tolls for the vehicle would be: 24130,34€



- c Cost of tolls for a EURO5 class vehicle, assuming that the viaTOLL system functiones:
  - The cost of road tolls in Poland: 11797,14 PLN = 2949,29 €
  - The cost of road tolls in Germany: 13894,07 €
  - The cost of road tolls in the Benelux: 786 €
- The total cost of tolls for the vehicle would amount to: 17629,36 €

Thus, during 18 months, the above mentioned vehicle in comparison with a new one, satisfying the EURO5 norm, would save 6,5 thousand Euros. It should be noted that at present the price of Mercedes Actros (EURO3) vehicle from the production year 2002 has a similar mileage range, from 65 to 80 thousand PLN, while the Mercedes Axor from the year 2007 (EURO5) varies from 145 to 170 thousand PLN. As a result, extra charge for changing would be about 100 thousand zlotys (or approximately 23 thousand Euros). If we assume that in the future car load will remain the same, during little over 5 years these investments must be recouped.

## 4 Conclusion

A similar analysis was conducted for all vehicles of Intertransport company, but also selectively taking into consideration other small transport companies of the Silesian economic region. Based on this, we can conclude that the introduction of a new system of road fees would lead to a temporary financial loss in transport enterprises. One method of solving this problem for companies is to invest in new vehicles or comparatively not old ones, which are in accordance with the EURO5 standard.

From the view of road management and countries economic foundations, the new system of road fees is advisable. They should contribute to the improvement of the environmental situation on the roads. Additional budget revenues must be used to improve the system of road facilities, because otherwise it may cause additional social tensions.

## References

- [1] 7,5 mln. złotych kary za spóźnione e-myto, [http://www.tvn24.pl/12690,1729609,0,1,7-5-mln-zlotych-kary-za-spoznione-e\\_myto,wiadomosc.html](http://www.tvn24.pl/12690,1729609,0,1,7-5-mln-zlotych-kary-za-spoznione-e_myto,wiadomosc.html), 30.12.2012.
- [2] Etapy wprowadzania opłat – Płatne drogi – Info myto, <http://www.info-myto.pl/P%C5%82atnedrogi/Etapywprowadzania/>, 11.07.2011.
- [3] Pojazdy ciężkie – Mapa – ViaToll, <http://www.viatoll.pl/pl/pojazdy-ciezkie/mapa#text>, 12.07.2011.
- [4] Słowik T., Jackowska I., Piekarski W.: Problemy zanieczyszczenia środowiska przez infrastrukturę transportową na przykładzie Roztoczańskiego Parku Narodowego. Instytut Agrofizyki, Lublin, 2008.

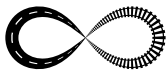

## TRACK ACCESS CHARGE ALGORITHMS IN EU RAILWAYS: A DYNAMIC BENCHMARKING

Francesca Ciuffini<sup>1</sup>, Stefano Ricci<sup>2</sup>, Giulio Rocco Sitongia<sup>1</sup>

<sup>1</sup> RFI, Italy

<sup>2</sup> Sapienza University of Rome, Italy

### Abstract

In this paper an overview on Track Access Charge systems in Europe is presented. TAC systems from 15 countries are compared from the point of view of the algorithm used to calculate the fee that Railway Undertaking has to pay to the Infrastructure Manager, to use the infrastructure with a specific train, in a specific time and on a specific route of the network. The aim of the benchmark and comparison analysis is to highlight the diversity, analogies and typical features of different systems, allowing a comprehension of existing pricing logics of railway infrastructure. Method and some results of the analysis are presented in the paper. The analysis starts from our own Network Statement's interpretation and leads to set them in a common framework, through the identification of a general formula. The classification of the system in homogeneous groups is therefore proposed together with a graphical synthetic representation in a three-dimensional space. In the research framework two different dynamic tools have been developed and presented in the paper: 1) a synoptic dynamic table, capable to facilitate comparison and understanding of different systems, providing a synthetic vision of pricing elements; 2) a dynamic tool, allowing comparison in a charging level, for any network and services classification.

*Keywords: track access charge, network statement, railway package, infrastructure manager, railways undertakings*

### 1 Introduction

In the last twenty years, the EU railway sector was interested in an important process of regulatory renewal, dealing with vertical separation among infrastructure and transport and free access to the infrastructure network. Goals of the railway reform were the development of the rail and enhancement of international traffic. In this new context what was before managed by a unique integrated railway company has been split into different subjects: one responsible for capacity allocation among applicants is in general the Infrastructure Manager (IM), who then sells capacity to the Railway Undertakings (RU) paying for assigned train-paths Track Access Charge (TAC). Therefore, capacity and TAC are the exchange elements between the IM and RU-s.

National pricing systems are quite different, due to different goals and different IM's pricing policies. Different are also average charging levels, depending on unit infrastructure costs, intensity of traffic on the network and, above all, level of State funding. Non-homogeneity in TACs is a critical element of the new regulatory system and problems of harmonization have been pointed out by the EU Commission, which presented a Recast version of the 2001 Railway Package Directives.

Many research works, often based on questionnaires or interview of the IMs, have been developed in the last years to compare pricing systems, from specific points of view, or to compare resulting charging level. For instance, relevant topics have been pointed out in OECD 2005 [1] and OECD 2008 about Marginal/Full Costs charging philosophies and consequent cost recovery rate by the access charge. Also in the OECD 2005 and 2008, a wide comparison in charging level has been given, on average and under specific, fixed conditions, i.e. market segments (freight/regional/long distance) and weight of the train. In the CENIT Railcalc research, dealing with general objectives related to the charging practice, a wide inventory of single systems is made and an assessment of current practices is given. Most of the research points out the heterogeneity of calculation methods as well as different levels of resulting charge. Regarding the first point, systems seem to be undoubtedly different among each other. As a matter of fact some analogies among different systems can be found and with common formalization an aggregation by similar families can be made.

Aim of the research, through the direct analysis of the algorithms, is: 1) to discover a possible common formalization of the formulas in order to frame different methods in similar families, focusing on analogies, differences and typical features; 2) to focus on the variation law of the charge, to better understand pricing parameters which influence the variation and the possible amplitude of the variation in order to give a more structured and synthetic view of the possible pricing logic of the charging systems.

The method used for such analysis is as follows: 1) interpretation of calculation methods from single Network Statements (NS) 2) identification of common features and definition of a general formula to frame different systems 3) construction of a synoptic dynamic table, as a synthesis of NS, to facilitate comparison and understanding of pricing parameters 4) classification of different system in homogeneous groups 5) examination of the variation law through graphical representation on abacus for each homogeneous groups 6) definition of a simple dynamic tool, to compare charging level, for any network and services classification. In the paper the method and some results of the research are presented.

## 2 Common frame and a general formula for algorithm analysis

From the Network Statement published on the IMs' web-sites, an individualization of a single algorithm has been made. Every IM uses his own formula and different symbols to identify similar parameters. Therefore, the first procedural step has been to translate the single algorithms in the same formalization.

As a first general synthetic formula the following one can be considered for the charge paid by a train running on a certain route of the network:

$$\text{CHARGE} = \text{LINE CH.} + \text{STATIONS CH.} + \text{OTHER} \quad (1)$$

The total charge is in general obtained as the sum of a charge for the use of the line infrastructure and a charge for the use of stations along the route. This second addendum is not always present. In this last case the charge for the use of stations is already included in the first one. The third addendum can include specific items, as externalities or specific crossings. Table 1 resumes the contributions considered in the examined systems. In the paper the focus is on the line charge only. A similar method is applicable for station components too.

**Table 1** Charge addenda

	Line	Stations	Other addenda
Prorail, ÖBB, MAV, DB, REFER, PLK, INFRABEL, ADIF	✓	✓	
SBB	✓	✓	Bonus for low noise vehicles
SZDC, SŽ, HŽ, RFF, RFI	✓	NO	
Trafikverket	✓	NO	Externalities for diesel Charge for specific crossings (e.g. Oresund)

## 2.1 Line charge

Regarding the first addendum, line charge, the following basic formula is proposed:

$$\text{LINE CH} = P_{\text{km}}(L, T, \dots) * K * \text{km} + P_{\text{tkm}}(L, T, \dots) * t * \text{km} + F \quad (2)$$

Where  $P_{\text{km}}$  is the unit price per train-km,  $P_{\text{tkm}}$  is the unit price per t-km and  $F$  is a fixed part, only present in a few systems. Both unit prices can in general depend from line ( $L$ ) and train ( $T$ ) categories or in few cases on further parameters, often considered by  $K$  modulators. This is the most general possible formulation. As better explained in the following chapters, various systems can be classified in different groups depending on how many addenda (1, 2 or 3) they take into account.

## 3 A synoptic table from Network Statements

Considering all possible addenda for the line charge, stations charge and other components, a general synoptic table, structured as a hypertext, has been developed from NS. For each IM and for each possible item a link to the tables from NS allows us to have, at a glance, a complete view of the structure and used parameters. Regarding the line charge, the components considered in Fig. 1 are the following: 1) Kilometric [ $P_{\text{km}} * \text{train-km} * K$ ] 2) Weight [ $P_{\text{tkm}} * t\text{-km}$ ], 3) Supplement or reduction per train-km 4) Supplement or reduction per t-km. The last two items may increase or reduce basic price. A time component [ $P_{\text{min}} * \text{minutes} * K$ ] is also considered, as an alternative only in one case (nodes in Italian system).

**Figure 1** A synoptic table from the Network Statement (extract)

From the NS table parameters considered to modulate the basic price and possible defined values may be derived. Parameters and symbols are exactly the same as proposed in the single NS, even though framed in a common structure. As a next step, more structured synoptic tables have been created, with parameters forced to algorithms homogeneity. Regarding line charge, classification of different algorithms can be made depending on how many addenda they have, as better detailed in the next chapter.

## 4 Classification of the algorithm for line charge

### 4.1 First group: simple formula without weight dependence

A first group of algorithms includes systems calculating the charge by a basic unit price multiplying run kilometres. Within this first group we can find system from Slovenia, Croatia, Germany and Portugal. For all these systems the basic price is modulated depending on categories of lines and trains:

$$\text{LINE CH} = P_{km} * L * \tau * K * km \quad (3)$$

Where  $L$  is a factor depending on line category,  $\tau$  is depending on train category and  $K$  is further modulating the charge. Despite the apparent diversity from NS explanations, these 3 systems have exactly the same algorithm structure, with differences on line and train categories only. The portuguese system is conceptually the same, though the basic price is not computable by a product of factor  $L$  and  $\tau$ , but specifically defined for each combination of line and train category. Systems of the first group can also consider a further modulation incremental factor (i.e. for heavily utilized sections, slow trains and regional factors). Germany also considers a supplement per train-km for trains heavier than 3000 t, but in all the remaining cases the weight has no influence on the charge.

In Fig. 2 the amplitude of the resulting charge is shown, considering the minimum and maximum of freight and passengers in a regional line as well as on a main line, for specific cases (Slovenia and Croatia) as an example.

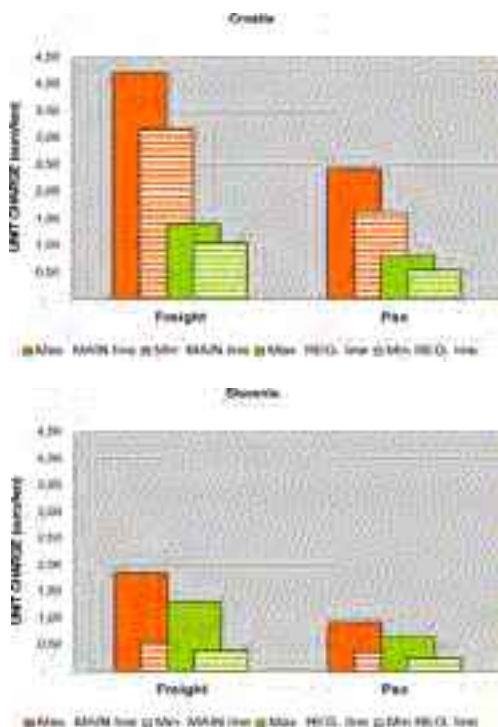

Figure 2 Amplitude of variation for the first group (example)

## 4.2 Second group: simple formula with weight dependence

In the second group, besides the component per train-km, again depending on lines' categories, a second component per t-km determines the charge.

The formula now has a second addendum, depending on the weight of the train:

$$\text{LINE CH} = P_{km} * L, T * K * km + P_{tkm}(L, T) * t.km \quad (4)$$

In the same group we can also consider a specific sub-group (Belgium and Poland, not reported in the table) with only the charge per train-km, but with a unit price depending also on the weight category of the train. So in Polish case the price is depending on the line category as well as on the weight class of the train; in the Belgian case the price is modulated on the basis of the line category (with double characterization: operational importance and speed), the train category and the weight class. The charge variation is therefore linear with the weight of the train as represented in the first graphic of Fig. 3, where an example from Sweden, Netherlands and Austria is reported. In these cases gradient is the same within the same system, because of a unique value for price per t-km, but the intercept is different, depending on line's category and related kilometric price.

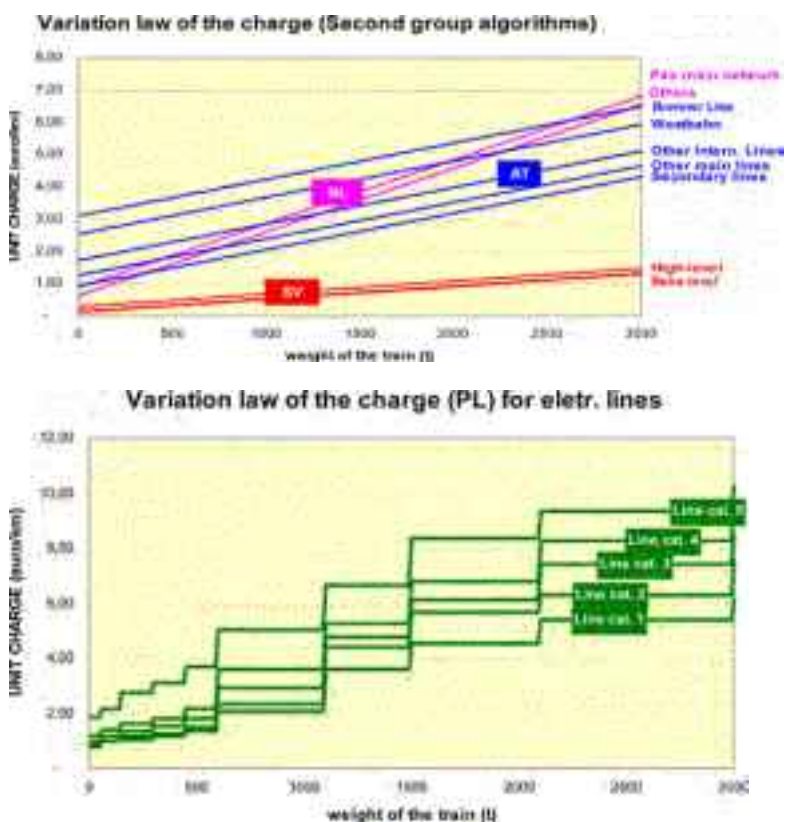

Figure 3 Charge variation for the second group (examples)

For other systems (e.g. Switzerland or Czech Republic) the gradient is also different, because the unit price per t-km varies according to the train or line category. For the Poland and Belgium sub-group, with a kilometric unit price depending also on the weight, the charge

variation with weight is discrete (second graphic of Fig. 3). Also systems of the second group can also consider a further modulation factor, i.e. for bottlenecks and freight traffic incentives (Austria), energy access (Hungary and Switzerland), galleries longer than 30 km (Switzerland), which increases or reduces unit price per train-km or per t-km. Another supplement is foreseen in Switzerland with a percentage on RU's revenues established by the Regulator.

### 4.3 Third group: complex formula with a fixed part

In the last group of formulas, a third contribution is added. In Italian and French cases it is a fixed part per section of line, charged whatever the length of the route run by the train: this means that the final charge per train-km may vary also depending on the length of the section and the route of the train. In the second graphic of Fig. 4 an example for the Italian case shows the unit price resulting from the fixed part: this is to be added to the kilometric rate. Values of the fixed part are defined for each section of the network, depending on the technical equipment. The French case is similar; the only difference is in the modulation of the fixed part, with a greater variability depending on line category, time window and train's features. In both cases this fixed part is supposed to be a reservation charge, which exist also in the Spanish formula as a part of the kilometric fee.

In Spanish and French systems a fixed access charge has to be paid only once, for the whole timetable period, by each RU running on the network in Spain and only by the regional trains in France. In the first case the amount varies depending on class of yearly volumes, in the second one it is directly defined for each Region. In both cases the bigger the amount of annual train-km run by the RU the lower will the kilometric extra fee deriving from the fixed part be. Last possible fixed contribution, fee per train, is foreseen by the Hungarian and Swiss systems, nevertheless considered as a simple tariff in the second group.

A common feature in the third group is the greater complexity of the algorithm, depending on a larger number of parameters: a time window, considered in Italian, French and Spanish systems, the specific train-path only in Italy, where commercial and running speed of the train are needed to calculate the charge. Something similar exists in Belgium, where differences between the commercial speed of the train and the standard speed of the line section influence the charge through specific modulation coefficient. The last common feature in the group is that wear and tear is not directly charged through the weight of the train: for instance, in the Italian case it is charged as a function of weight and square running speed (proportional to energy). Variations by weight of the train are represented for the Italian case in the first graphic of Fig. 4. In the Spanish and French systems other parameters are considered for wear and tear as number of seats or speed of the freight train.

## 5 Graphic synthetic representation of the charge variation

A synthetic graphic representation of the possible algorithms in a 3-dimensional space is shown in Fig. 5, with unit resulting charge (Euro/km), depending on run kilometres and weight of the train: formulas of the first and second groups, not having fixed parts, can be represented in the space by a plane (or a step) surface, with a gradient on the weight axis due to the second group of algorithms, with charge varying depending on the weight. The presence of fixed parts in the third group curves the plane, bringing a reduction of total charge with the length of the route. The intercepts of the plane change according to train and line category and further parameters. The difference between the structures of the algorithms can be thought in terms of different surfaces per shape, intercept or gradient.

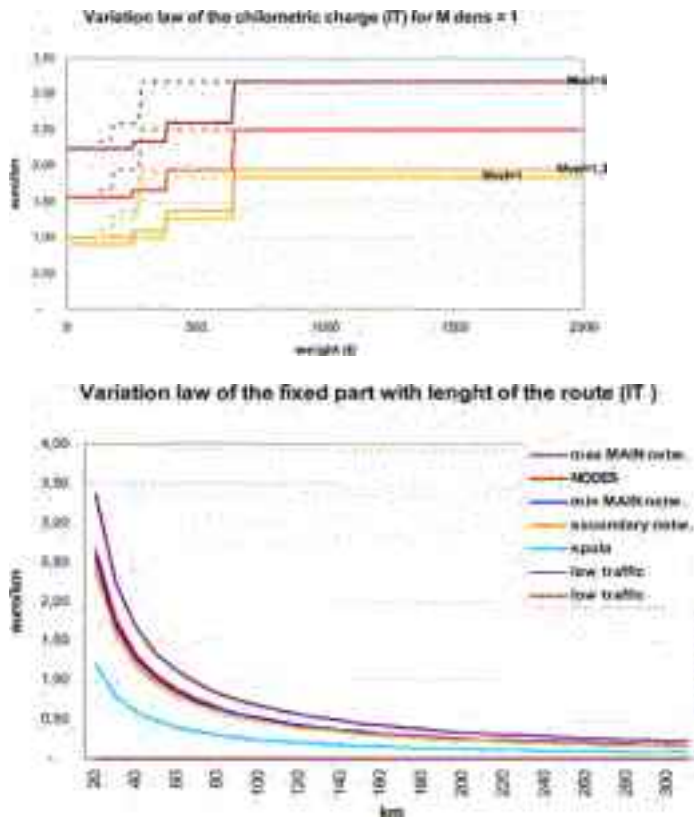

Figure 4 Charge variation for third group: Italian case with dependence on weight and length of the route

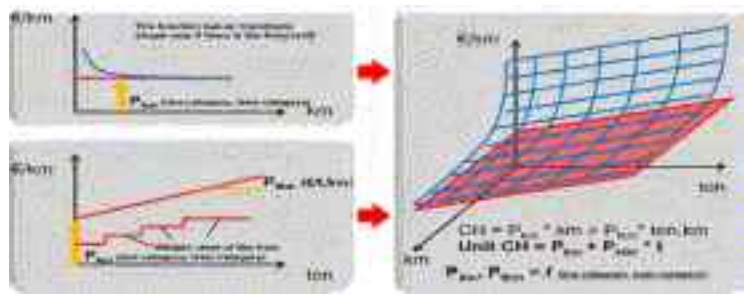

Figure 5 General graphical representation of the line charge formula

## 6 A dynamic tool for specific comparisons

Starting from the common frame and the involved parameters it is possible to develop a dynamic tool (Fig. 6) to calculate in real time the resulting charge per train-km in similar conditions. Selectable parameters are line and train category, weight of the train, length of the route. Extra parameters are a priori defined under certain hypothesis (i.e. commercial or running speed for different trains in the Italian system), but they can be checked and changed if needed.





**Figure 6** Dynamic tool example for line charge comparison

By means of this tool a specific comparison between different systems can be made to highlight the largest difference among the systems (e.g. different categorization of lines and trains). The aim of the tool is different from EICIS, the RNE platform for RU-s to simulate the charge for a specific route of the network. The present tool is mainly conceived for IM-s or regulators reasoning and debating about the possible charging models.

## 7 Conclusions

A structured analysis of railway charging algorithms, at first sight very different from each other, was presented in the paper with focus on the method and some results of the research. Through the definition of a common general formula, single systems could be the frame in a common structure and classified in three homogeneous groups. The synoptic tables and the dynamic tool developed for line charge are thought as means to reason about possible railway charging schemes. The charging model defines the possible variations of the charging, particularly defining what and how much to let pay (wear and tear, willingness to pay, scarcity of capacity etc.), with results in terms of different charging level between market segments and category of the network, but also in terms of minor or greater complexity of the calculation method and legibility of the system.

The research will be extended to other European systems and to develop the dynamic tool also for stations charge, with an improved interface and the possibility to share the tools among the IM-s.

## References

- [1] CENIT, TIS PT, IWW, HERRY, RailCalc, Calculation of charges for the use of rail infrastructure, 2007
- [2] CER, Position paper - Track Access Charges, 2010
- [3] EICIS, RailNetEurope, [www.rne.eu/](http://www.rne.eu/)
- [4] EIM Position Paper on charging, 2010
- [5] Esveld, C.: Modern Railway Track, Second edition, TU-Delft, 2001.
- [6] OECD-ECMT, Railway Reform & Charges for the Use of Infrastructure, 2005
- [7] OECD-ECMT, Charges for the Use of the Rail Infrastructure, 2008
- [8] Network Statement from ADIF, DB, HŽ, Infrabel, MAV, ÖBB, PLK, Refer, RFF, RFI, SBB, SŽ, SZDC, Prorail, Trafikverket,
- [9] UIC, Infrastructure charges for high performance passenger services in Europe

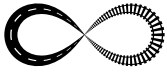

## A NEW METHODOLOGY FOR ASSESSING THE PERFORMANCE OF ROAD SURFACE MARKINGS

Francesco Asdrubali, Cinzia Buratti, Elisa Moretti,  
Francesco D'Alessandro, Samuele Schiavoni

*CIRIAF, Interuniversity Center of Research on Pollution by Physical Agents,  
University of Perugia, Italy*

### Abstract

CIRIAF, in cooperation with the Municipality of Perugia (Italy), is participating in a research project whose aim is to define a methodology for road markings in-situ measurements.

The objective is to take into account the characteristics of the site of installation of road markings in order to improve safety, to optimize the maintenance and to give the municipality a tool to verify the quality of the application, in order to assess if the requirements given in tenders are fulfilled. The activity is performed within the framework of the EU FP7 funded project CIVITAS Plus 'RENAISSANCE'.

In particular, an innovative indicator was developed, in order to rate the global quality of municipal road markings. This indicator takes into account all the parameters characterizing the performance of road markings: luminance coefficient in daylight conditions  $Q_d$ , retroreflectivity in night conditions  $R_L$  (dry, wet), skid resistance  $SRT$ , colour, material and ageing of the pavement markings, traffic volume, road surface characteristics and average local weather conditions.

This paper, after the first section about the methodology for the evaluation of the performance of road surface markings, reports the definition of the new indicator and the results of the experimental campaigns carried out on several roads of the Perugia municipality.

*Keywords: road markings, monitoring, safety, maintenance, retroreflection*

### 1 The CIVITAS + 'RENAISSANCE' Project

The 'RENAISSANCE' Project (full title: 'Testing Innovative Strategies for Clean Urban Transport for historic European cities') is co-funded by the European Union within the 7th Framework Programme CIVITAS Initiative (Plus edition 2008–2012) [1].

The goal of the RENAISSANCE project is to develop a valid, reliable and integrated package of access and mobility measures for historic cities. The cities involved in the project are: Perugia (Italy) – Project Leader (Fig. 1), Bath (UK), Szczecinek (Poland), Gorna Oryahovitsa (Bulgaria) and Skopje (Republic of Macedonia).



Figure 1 Logo of CIVITAS+ RENAISSANCE for the city of Perugia.

The activities are performed by five cities in cooperation with other 25 partner companies and research organizations, experts in the field of transport and mobility. Within the framework of the measure 5.2 of the project, 'Assessing the options for more efficient road pavement markings', CIRIAF, in cooperation with the Municipality of Perugia, focused research activities on the study of the performance of road surface markings. These activities aim at defining a modus operandi for in-situ measurement able to take into account the characteristics of the site of installation of road marking, in order to:

- optimize the maintenance;
- give the municipalities a tool to verify the quality of the application in order to assess if the requirements given in tenders are fulfilled.

This second aspect is particularly important for public administrations: as a matter of fact the current evaluation of the performance of road surface markings performed by the Municipality of Perugia is made purely by verifying the products used in terms of quantity, and by a visual judgment of the amount of paint used, without any experimental support.

## 2 Parameters for the evaluation of road markings performance

The incidence of pavement marking on traffic safety and driving comfort is considerable [2, 3]. The European Standard EN 1436 [4] specifies the performance for road users of white and yellow road markings based on luminance (colour), day-time visibility, night-time visibility and skid resistance, combined with durability. The specification also introduces the importance of wet-night visibility road markings. Furthermore, it describes the methods of measuring the various performance characteristics reported below.

Luminance is the property of the marking which describes the brightness of its colour.  $Q_d$  measures, true to scale, the luminance (day visibility) of a road marking. The observation angle of  $2,29^\circ$  corresponds to the viewing distance of a motor car driver of 30m under normal conditions. Illumination is diffused light.

Retroreflection is the ability of a road marking to reflect light from the vehicle's headlights back to the driving position of a vehicle. The performance of the line is determined by the amount and quality of glass beads included in the body of the road marking.  $R_L$  measures, true to scale, the retroreflection (night visibility) of a road marking. The observation angle of  $2,29^\circ$  corresponds to the viewing distance of a motor car driver of 30m under normal conditions. The illumination angle is  $1,24^\circ$ .  $R_L$  is measured in three different conditions of road markings: dry, wet and rain.

Colour is defined by the luminance factor  $\beta$  and chromaticity, which represents the co-ordinates falling within a defined square on the chromaticity diagram defined by EN 1436 for white (left) and yellow (right) road markings.

Skid resistance measurement on road markings is carried out using the standard British pendulum apparatus. The instrument, which is direct reading, gives a measure of the friction between a skidding tyre (a rubber slider mounted at the end of the pendulum arm) and a wet road surface. The quantity measured with the portable tester is called 'Skid-resistance' and it is correlated to the performance of a vehicle with patterned tyres braking with locked wheels on a wet road at 50 km/h.

EN 1436 defines the classes of performance requirements for white (a) and yellow (b) road markings (Table 1).

**Table 1** Classes of performance of white road markings defined by EN 1436.

RL (dry conditions) [mcd/ (m <sup>2</sup> ·lux)]		RL (wet conditions) [mcd/(m <sup>2</sup> ·lux)]		Qd [mcd/(m <sup>2</sup> ·lux)]		SRT [SRT]	
Class	Value	Class	Value	Class	Value	Class	Value
RO	NIL	RW0	NIL	Q0	NIL	S0	NIL
R2	≥ 100	RW1	≥ 25	Q2	≥ 100	S1	≥ 45
R3	≥ 150	RW2	≥ 35	Q3	≥ 130	S2	≥ 50
R4	≥ 200	RW3	≥ 50	Q4	≥ 160	S3	≥ 55
R5	≥ 300	RW4	≥ 75			S4	≥ 60
		RW5	≥ 100			S5	≥ 65
		RW6	≥ 150				

### 3 Definition of the methodology for monitoring the performance of road markings

The main objective of the research is to develop a methodology to verify the efficiency of road pavement markings, depending on installation conditions and available technologies. The results will allow the road marking department of the Municipality of Perugia to use new procedures to control the quality of works performed by external contractors.

#### 3.1 Selection of test sites

28 experimental campaign sites were selected in collaboration with the road markings staff of the Municipality of Perugia.

The choice of measurement locations was guided by the necessity to guarantee upscaling throughout the road network managed by the Municipality; therefore the chosen sites are representative of several conditions which can be found throughout the roads crossing the whole territory of Perugia.

Three main parameters were considered for the selection: (i) road surface, (ii) marking material, (iii) traffic flow.

Three road surface conditions were identified: smoothness, roughness and other (for example presence of cobblestones).

All the road marking materials used in the Municipality were considered (paint, thermoplastic, two-components, preformed) in order to compare performance.

The Municipality of Perugia road network was divided into three classes, depending on the traffic flow (source of traffic data: Urban Plan of Traffic): (i) low, < 600 vehicles/hour; (ii) medium, 600 – 1500 vehicles/hour; (iii) high, > 1500 vehicles/hour.

When measurements are carried out in municipalities other than Perugia the number of sites, the types of material, the ranges of traffic flows, etc. will of course differ. The selection of the test sites should be undertaken considering the characteristics of the roads managed by the Municipality.

### 3.2 Measurements execution

In each test site the following measurements were carried out:

- Retroreflection in dry ( $R_{LD}$ ) and wet ( $R_{LW}$ ) conditions and Luminance ( $Q_d$ ), using a retroreflector Zehntner ZRM6013 RL+ $Q_d$ ;
- Colour (chromaticity x,y), using a spectrophotometer Konica Minolta CM-2500c;
- Skid resistance (SRT), using a portable Skid Resistance Tester Zehntner SRT 5800;
- Other parameters: marking thickness, air temperature and humidity, road surface temperature, etc.

For each site, several measurement points were chosen, depending on the type (centre lines, sidelines, pedestrian crossings, stop lines, letters, etc) and the size of the markings. Measurements were always carried out in safety, thanks to the support of the local police.

### 3.3 Data processing

The goal of the developed data processing procedure is to assign a score to each site, combining all the measured parameters. Only white markings were considered in this research. A scale of scores was established for each parameter, according to the tables given by EN 1436 (Table 1). Scores (Table 2) go from 0 (worst) to 10 (best) and 6 represents the minimum requirement defined by EN 1436.

**Table 2** Definition of scores for the measured parameters.

Score	$R_{LW}$	$R_{LD}$	$Q_d$	SRT	Colour
0	0-2	0-9	0-9	0-19	No
1	3-4	10-19	10-19	20-24	
2	5-9	20-39	20-39	25-39	
3	10-14	40-59	40-59	30-34	
4	15-19	60-79	60-79	35-39	
5	20-24	80-99	80-99	40-44	
6	25-49	100-149	100-114	45-49	
7	50-74	150-199	115-129	50-54	
8	75-99	200-249	130-144	55-59	
9	100-150	250-300	145-160	60-65	
10	>150	>300	>160	>65	Yes

For each site the results obtained for the different parameters are average, obtaining a mean value for  $R_{LD}$ ,  $R_{LW}$ ,  $Q_d$ , SRT and Colour (x,y).

For the j-th site, two different scores are calculated:

- score in dry conditions  $S_{Dj}$ ;
- score in wet conditions  $S_{Wj}$ .

These two indicators are obtained weighting all the parameters, through the following equations:

$$S_{Dj} = (SR_{LDj} * wR_{LD})_D + (SQ_{dj} * wQ_d)_D + (SColour_j * wColour)_D \quad (1)$$

$$S_{Wj} = (SR_{LWj} * wR_{LW})_W + (SQ_{dj} * wQ_d)_W + (SSRT_j * wSRT)_W + (SColour_j * wColour)_W \quad (2)$$

where  $SX_j$  represents the score of the X-th parameter (Table 2) in the j-th site. The values of the weights  $wR_{LD}$ ,  $wColour$  and  $wQ_d$  in dry condition and  $wR_{LW}$ ,  $wQ_d$ ,  $wSRT$  and  $wColour$  in wet conditions were defined considering their influence on safety conditions for road users. They are reported in Table 3. The global score for the j-th site  $S_j$  is given by:

$$S_j = (D_w / 365) * S_{Wj} + (D_d / 365) * S_{Dj} \quad (3)$$

where  $D_w$  is the number of days of rain/snow per year (wet conditions) and  $D_d$  is the number of days without rain/snow per year (dry conditions) in the Municipality where the measurements are carried out (of course  $D_d + D_w = 365$ ).  $D_d$  and  $D_w$  should be obtained from at least 10 years of weather data.

**Table 3** Definition of weights for the investigated parameters.

Weights	Wet condition	Dry condition
$wR_{TW}$	0.55	-
$wR_{TD}$	-	0.75
wQd	0.2	0.2
wSRT	0.2	-
wColour	0.05	0.05

Once all the selected sites are investigated, it is possible to define a single score for the entire Municipality, CIS-Q (Civitas Indicator for Stripes – Quality).

First of all the score of the  $i$ -th marking material  $S_{Mi}$  (paint, two components resin, thermoplastics, tapes, other) has to be evaluated by means of Eq. (4):

$$S_{Mi} = \frac{\sum_{j=1}^N S_j}{N} \quad (4)$$

where  $n$  is the number of sites where the  $i$ -th typology of material is used. Then CIS-Q can be calculated with Eq. (5):

$$CIS-Q = \sum_{i=1}^M S_{Mi} \times P_i \quad (5)$$

where  $m$  is the number of materials used in the Municipality for road markings and  $P_i$  is the percentage of usage of the  $i$ -th material.

This procedure was developed in order to allow its use all over Europe (it is referred to European standards), since it can consider several types of material and their percentage of usage in the considered Municipality, road surface conditions, traffic flows and weather conditions without restrictions.

## 4 Measurement results

Results of the experimental campaign on the selected 28 sites were collected and processed with the developed methodology. The synthesis of the results is reported in Table 4. The last column reports the global score  $S_j$  for each site, calculated using Eq. (1), (2) and (3). The red (green) face represents a score lower (higher) than 6.0.

In Table 5 the scores  $S_{Mi}$  calculated for each material using Eq. (4) are reported, in Table 6 is the percentage of usage  $P_i$  of the materials in the road network managed by the Municipality of Perugia (data from the Municipality road marking staff). Finally, the global index CIS-Q is evaluated by means of Eq. (5): for the road markings system of the Municipality of Perugia CIS-Q is equal to 4.4.

Table 4 Results of the experimental campaign in the Municipality of Perugia.

Test Site CODE	Test Site Name	$R_{10}$ (mmol/m <sup>2</sup> /yr)	$R_{10}$ (mmol/m <sup>2</sup> /yr)	Q <sub>10</sub> (mmol/m <sup>2</sup> /yr)	SHT (°C)	Colour	Test Site Score $S_M$
W-F-R-L-001009	Via Garbino	27	18	120	30	Green	5.4
W-F-R-L-002009	Via Garbino (Hogressina)	100	33	100	42	Red	6.4
W-F-R-L-003009	Via Costa	120	34	170	47	Green	7
W-F-R-L-004009	Piazza Livio e Jane	132	30	130	41	Green	6.7
W-F-R-L-005010	Via Montebello	60	11	100	38	Red	4.8
W-F-R-L-006010	Via Serravalle	139	28	123	49	Green	6.4
W-F-R-L-007010	Via Serravalle	60	20	151	46	Green	6.8
W-F-R-L-008010	Via Donari	60	17	113	43	Red	4.2
W-F-R-L-009010	Via Serravalle ex 123 (San Pietro)	34	10	113	37	Red	3.9
W-F-R-L-010010	Via Garbino	120	37	109	39	Green	6.1
W-F-R-L-011010	Piazza Montebello	100	20	97	44	Green	6.8
W-F-R-L-012010	Via dei Fiumori	25	14	107	41	Red	3.4
W-F-R-L-013010	Via Palumbo	60	30	139	49	Red	6.2
W-F-R-L-014010	Via Palumbo	77	18	120	43	Green	6.1
W-F-R-L-015010	Via Lino Spagnoli	60	34	118	52	Green	3.7
W-F-R-L-016010	Via Costanzo	24	12	200	31	Red	4.2
W-F-R-L-017010	Via Costanzo	60	30	151	31	Green	6.8
W-F-R-L-018010	Viale dell'Indipendenza	23	6	96	42	Red	3.1
W-F-R-L-019010	Via Quella	27	7	120	49	Green	3.6
W-F-R-L-020010	Stazione FF.SS. S.	24	13	171	48	Green	4.4
W-F-R-L-021010	Strada Provinciale di Ombra - San Marco	23	12	94	43	Red	3.2
W-F-R-L-022010	Via Costanzo	61	30	80	21	Green	6.5
W-F-R-L-023010	Via dei Fiumori	117	33	90	33	Green	6.8
W-F-R-L-024010	Viale dell'Indipendenza	20	2	110	45	Green	3.3
W-F-R-L-025010	Via Garbino (San Marco)	100	37	80	48	Green	6.6
W-F-R-L-026010	Via Pisto della Fontana	67	31	219	47	Green	6.8
W-F-R-L-027010	Via San Giuseppe	61	8	80	48	Green	4.3
W-F-R-L-028010	Viale Christi Azzurri	70	19	80	42	Red	4.8

Table 5 Score  $S_M$  for the different road markings materials in the Municipality of Perugia.

	Paint	Two-Component	Tapes	Thermoplastic	Others
$S_M$	4.2	5.4	6.2	6.0	5.5

Table 6 Percentages of use of the road markings materials in the Municipality of Perugia.

	Paint	Two-Component	Tapes	Thermoplastic	Others
$P_i$	90	8	1	1	≈0

## 5 Conclusions

The results of the measurement campaign show that the current system of road marking management in the Municipality of Perugia does not allow fulfilling the requirements of tenders in terms of road markings performance because of the lack of technical/instrumental control and the intensive use of pre-mixed paint. The measurement carried out during the project demonstrated that this material, even if freshly applied, can not reach sufficient levels of performance, especially in terms of night visibility.

The results of this campaign allowed CIRIAF to give to the Municipality road marking staff some useful indications for the new public tender, in order to verify the quality of the pavements markings:

- execution of a technical/instrumental control 1 month after the realization of the horizontal markings;
- execution of a technical/instrumental control 6 months after the realization of the horizontal markings, but before the final payment of the contractor by the Municipality.

This procedure aims at improving the quality, the performance and the safety of horizontal markings of the Municipality of Perugia, because the requirements of the public tender and the introduction of stricter controls force the contractors to use more performing materials than the ones used before this project.

The proposed methodology is reliable and can be easily transferred to different situations, since it takes into account the influence of local weather conditions on road markings efficiency.

## References

- [1] [www.civitas.eu](http://www.civitas.eu) (website of the CIVITAS Initiative) and [www.civitas-renaissance.eu](http://www.civitas-renaissance.eu) (website of the RENAISSANCE project), 14.02.2012
- [2] Parker, N. A. & Meja M.: Evaluation of the Performance of Permanent Pavement Markings, 84th Transportation Research Board Annual Meeting, Washington, 2003.
- [3] Horberry, T., Anderson, J. & Regan, M. A.: The possible safety benefits of enhanced road markings: a driving simulator evaluation, Transportation Research Part F, 9, pp. 77-87, 2006.
- [4] CEN (European Committee for Standardization), CEN/TC 226 - Road equipment: EN 1436:2007+A1:2008, Road marking materials - Road marking performance for road users, 2007-2008.





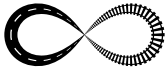

## A TENTATIVE TOLL MOTORWAY SOLUTION ON DURRES–TIRANA–ELBASAN ROAD CORRIDOR

Faruk Jusuf Kaba

*InfraTransProject Ltd., Albania*

### Abstract

Albania is facing a challenging task regarding the further development of its transport infrastructure. With the accession to the European Union in mind, the Government of Albania has committed itself to providing some roadway links identified as being integral parts of the planned Pan European Corridors. Being crucial for the economic development of the wider Balkans area, the part that directly relates to Albanian interests is the 8th Pan European, also known as the East–West (Durres–Skopje–Sofia–Varna), Corridor.

At this time, both the East–West and North–South corridors in Albania are almost finished, but some sections of the national road network still require rehabilitation before the two strategic routes can be considered complete. Actually, the central part of the countries road network, especially the road section from Durres to Tirana and Elbasan, is of importance and interest. In the last 14 years, the road section from Durres to Tirana has been built as a 4–lane dual facility. The section Tirana–Elbasan was built in the 30s of the last century, and it's actually a 6–7m wide, paved, mountainous single carriageway.

Durres–Tirana–Elbasan corridor considers the concession project from the private sector. The roads in Albania are located in the economically most developed region. In this region, more than two thirds of the country's population lives, and more than 75 percent of the economy is concentrated there. Two primary corridors, North–South and West–East, intersect here. This region registers most of the transport vehicles. The traffic flow, in some sections of Tirana–Durres, records more than 35 000 AADT. If we take into consideration the very limited possibilities of other means of transport, the resolution of the road infrastructure under study in this central part of the Country is a challenge for Albania.

*Keywords: road network rehabilitation, traffic studies, financial analysis*

### 1 Project description

The actual transport infrastructure in Albania; roads, ports and airport don't have the adequate capacity for answering the increasing requests of the economy and the necessity for people transport. The road network in Albania includes about 18.210 km of roads, out of which 3.500 km are national roads. Only some 6.500 km is asphalted. Origin/destinations for most of the vehicles in circulation are in the Tirana/Durres/Rrogozhine/Elbasan area.

In order to improve the national road network, road axis North–South and West–East was financed and constructed. North–South road axis bonds Kakavia (Greece) with HaniHotit (Montenegro) across coastal Albania and Durres port. West–East axis bonds Durres port with QafeThana (border with Macedonia) and Kapshtice (border with Greece). Albanian population is situated mainly in the coastal area, directed towards west Europe and from west Europe towards Durres port. Works done on the national road system on both axes are new or rehabilitated.

The 8<sup>th</sup> European Corridor connects Bari and Brindizi (Italy) ports via Durres and Vlora (Albania) with Skopje (Macedonia), Burgas and Varna (Bulgaria), both ports on the Black Sea. It is known as one of the more interesting corridors of Europe (second Pan-European Conference held in Crete, January 1994).

Durres–Tirana–Elbasan corridor is part of the 8<sup>th</sup> Trans European Corridor and represents the project–interest area that needs to be considered as a concession case project. The three cities are actually linked with different alternative roads, including newly constructed highways and old national system of roads. This situation offers the possibility, for road users, to use the existing old network as a traveling alternative.

## 2 Project aim

Durres–Tirana–Elbasan road is located in the economically most developed part of Albania. In this region, more than two thirds of the country's population lives and more than 75 percent of the economy is concentrated.

From the transport viewpoint, the three main cities of the Central region, Tirana, Durres and Elbasan, are located there. Also, two primary corridors, North–South (HaniHotit–Kakavie) and West–East (8th Pan European Corridor) intersect there. This region registers about 75 percent of the transport vehicles and this is the ratio of the economic activity of the Country as well. The traffic flow in some sections of Tirana–Durres highway, records more than 35 000 AADT.

Traffic studies (Albania National Transport Master Plan by Luis Berger) advise urgent solutions for the transport infrastructure, otherwise major problems will occur in the short to medium term future.

Even with all the efforts and investments, the government of Albania cannot change the situation of the existing infrastructure to adjust the road network in accordance with today's motorway standard's and traffic demands. For example, Tirana–Durres highway, an almost new construction, faces problems on both guidelines: traffic and infrastructure itself. In the Tirana–Vora part the actual traffic flow is more than 35 000 AADT and in the next section, Vore–Durres part, the flow is about 26 000 AADT.

On the other hand, the Tirana–Elbasan segment is an old construction built in the 30s of the last century, when the traffic flow was not more than 200–300 AADT, with geometrical parameters of mountainous road and designated speed of 30 km/h. The aerial distance between the two cities is only 28 km, but the actual road alignment is 56 km long. The difference in length is produced because of the road elevation from 100 – 1 000 m that serves to overpass the mountains and to avoid tunnels, viaducts, and especially to avoid high construction cost. The factual travel distance is from 1.5 to 2 hours long. Road safety is very low. In addition, this road is extremely difficult and mostly, prohibited for freight transport.

This situation dictates deviation, of a considerable part of the traffic (almost 20%), from the direct route Tirana–Elbasan via mountain, to the prolonged route through Durres and Rogozhina to Elbasan and further, with more than 50–60 kilometres of extension and respective travel time.

Urgent traffic problems of this region, particularly for the Tirana–Durres section, will partially be solved by the new planned Thumane–Rrogozhine Toll Motorway, which intersects the Durres–Tirana highway in Ura Limuthit. Still, similar problems remain crucial for the other sections of the road network. The answer for the burning question is the converging of the existing 'four lane facility highway 2x2 lanes', into a full motorway, 3x3 lanes including all other motorway parameters (velocity, safety, fencing etc). There are some obstacles for accomplishing this task. The main obstacles are: Vora transient, the complicated interchange of Limuthi (planned interchange between Thumana–Rrogozhina Toll Motorway, part of the North–South corridor and Durres–Tirana motorway) and the Tirana By–pass. With these implications, the intervention with a Toll motorway project doesn't have a chance in protecting this corridor. Although, this solution could protect the road and not leave it to degenerate into a simple urban road. A later intervention will more

difficult and will have extreme high costs for the Country economy. This fact must be known to the Government of Albania.

The new idea for Durres–Tirana–Elbasan Toll motorway will also generate:

- An appropriate alternative for the 8th Corridor.
- Traffic transfer from the Elbasan, Macedonia end further, from Durres–Rrogzhine–Elbasan to Durres–Tirana–Elbasan.
- A rational solution for the transport system in two cities, Tirana and Elbasan.

The deviation of the major part of the traffic, from the existing roads, to this new alternative will contribute to smoothing the traffic and transport problems and improve the travel and transportation conditions. On the other hand, the short distances will influence the deviation of all the freight and partially of the light traffic to generate the supplementary traffic in the proposed alternatives. This will create opportunities for the Concession or PPP (Private Public Partnership) investments, where the private capital is very active. This perception, which must integrate both sections, is very dependent on this study case.

The terrain between three cities/centres varies from flat (Durres, Tirana) to hilly (partially Tirana) and mountainous (Tirana–Elbasan). Between three centres there is an existing road infrastructure (Durres–Tirana highway) or it is in the process of planning (ring of Tirana). In these specific conditions and circumstances, one of the main objectives of this study is finding new shorter and appropriate routes which would have minimum environment impact.,

### 3 Alternatives Description



Figure 1 Alternative 'A', 'B', 'C', 'D' and 'E'

### 3.1 Alternative 'A'

It is a 70 466 ml long route from Durres to Tirana to Elbasan, shown in Figure 1. The proposed alternative route suggests passing from Durres to Tirana through the existing 4-lane highway. The difference between the existing 4-lane highway and a full 6-lane motorway (toll or not) is in parameters:

- The width, from 2x2x3.50 and 0.8 median part and simple side shoulders 1.5m up to 2.0m, must change in a full motorway: 3x3x3.75m + 2.50m median part + 2x2.50m emergency lanes + 2x1.5m simple shoulders, all together 33.0m wide. . Changing from 2x2 lanes highway to 3x3 lanes motorway would hold up the very high traffic flow and change from 'four lane facility' in a full Motorway.
- Uncontrolled entrances and exits in the existing 4-lane highway. There are more than 10–12 uncontrolled entrances. Transforming the existing 4-lane highway into a motorway suggests closing of the entrance–exit roads and traffic control, which would organize traffic only on the referred points (toll or not toll).
- No toll alternative. A toll motorway doesn't suggest a toll alternative. But from Durres to Tirana, such an alternative already exists.

**Table 1** Table 1  
'A' – travel distance 70 466 ml, construction length 64 043 ml

No	Parts of the Alternative	To be financed	Rate	Amount
1	Durres–Tirana (1-2-3-4), L=32 549 ml	all	EUR	146,900,660.00
2	Tirana Ring (4-5-6), L=6 423 ml	not at all	EUR	0.00
3	Tirana–Elbasan (6-10-12), L=31 494	all	EUR	367,817,252.00
Total in EUR				514,717,912.00

### 3.2 Alternative 'B'

Travel distance is 72 845 ml long and is almost the same as, the alternative 'A'. The difference is that Alternative 'B' has a supplementary By-pass nearby Tirana.

**Table 2** Table 2  
'B' – travel distance 72 845 ml, construction length 84 886 ml

No	Parts of the Alternative	To be financed	Rate	Amount
1	Durres–Tirana (1-2-3-4) L=32 549 ml	all	EUR	146,900,660.00
2	Tirana By–Pass (3-8-9, 9-10) L=20 843 ml	all	EUR	159,266,443.00
3	Tirana–Elbasan (6-10-12) L=31 494 m	all	EUR	367,817,252.00
Total in EUR				673,984,355.00

### 3.3 Alternative 'C'

This alternative is in regard to the road from Durres (1) to Tirana entrance (4) and is similar to Alternative 'A'. The part from Kashar (3) to Arbana (9) is similar to Alternative 'B'. After this point, the Motorway continues according to a new direction alignment Baldushk–Plangarica–Paper (11), through Baldushk valley and Sollaku River. From km21+400 till 23+150 a 1 750 long tunnel is indispensable. In this paper (11) a new candidate route joins 8<sup>th</sup> Corridor. This candidate route suggests including the rehabilitation of the part from Tirana Ring (5) up to

Vaqar (8) segment in the investment. A full upgrade and partial widening is also necessary for the road segment from the Tirana Ring exit (5) up to point (8). This is not included in this estimation of the respective alternative because it is included in the already planned 'Thumana–Rrogozhina' Toll Motorway.

**Table 3 Table 3**

'C' – travel distance 85 319 ml, construction length 78 675 ml

No	Parts of the Alternative	To be financed	Rate	Amount
1	Durres–Tirana (1-2-3-4) L=32 549 ml	all	EUR	146,900,660.00
2	Tirana By–Pass (3-8-9) L=8 846 ml	all	EUR	60,444,437.00
3	Tirana–Elbasan (9-11) L=37 290 ml	all	EUR	309,548,613.00
Total in EUR				516,893,710.00

### 3.4 Alternative 'D'

This candidate route is more similar to Alternative 'B', with the difference of the By–pass: instead of Kashari (3), Vaqar (8), Arbana (9), the By–pass deviates from Limuthi (2), Ura Beshirit (7) to Arbana (9). The part from Limuthi (2) to Ura Beshirit (7) is a part of Thumane–Rrogozhine (Toll Motorway under the process of implementation). From the Arbana (9) point, the alignment extends into the Erzen valley, nearby villages of Arbana, Mullet, Petrela up to Fikas and Ura Peshkatarit(10), where Alternative 'A' joints further to Elbasan (12). For this alternative the construction length is also longer than the travel distance.

**Table 4 Table 4**

'D' – travel distance 71 693 ml, construction length 72 220 ml

No	Parts of the Alternative	To be financed	Rate	Amount
1	Durres–Tirana (1-2-3-4) L= 32 549 ml	all	EUR	146,900,660.00
2	Tirana By–Pass (2-7, 7-9, 9-10)	Partially 7-9-10 Lp=14, 977ml	EUR	110,820,483.00
3	Tirana–Elbasan (6-10-12) L=24694m	all	EUR	367,817,252.00
Total in EUR				625,538,395.00

### 3.5 Alternative 'E'

This candidate route is similar to Alternative 'C', with the difference of the By–pass: instead of Kashari (3), Vaqar (8), Arbana (9), the By–pass deviates from Limuthi (2), Ura Beshirit (7) to Arbana (9). The Limuthi (2) part up to Ura Beshirit (7) is a part of Thumane–Rrogozhine (Toll Motorway under the process of implementation). From Arbana (9), the Motorway continues according to direction alignment Baldushk–Plangarica–Paper (11), through Baldushk valley and Sollaku River. This candidate route suggests the rehabilitation of the section from Tirana Ring (5) up to Vaqar (8): full upgrading and partially widening the existing road. It is not included in the estimation of the alternative because another project; 'Thumana–Rrogozhina' has it planned already.

**Table 5 Table 5**  
'E' – travel distance 84 167 ml, construction length 74 114 ml

No	Parts of the Alternative	To be financed	Rate	Amount
1	Durres–Tirana (1-2-3-4) L=32 549 ml	all	EUR	146,900,660.00
2	Tirana By–Pass (2-7;7-9 and 9-11)	Partially:7-9; L=2, 900 ml	EUR	11,998,477.00
3	Tirana–Elbasan (8-9-11) L=38 665 ml	all	EUR	309,548,613.00
Total in EUR				625,538,395.00

## 4 Economic and traffic analysis

The full study suggests a prefeasibility study which would be done with World Bank Standard HDM IV including Environment Impact Assessment. The prefeasibility study would include:

- The proposed road corridor
- Socio–economic indicators and traffic growth
- Population
- The growth of the Vehicle Fleet in Albania
- The value of travelling time, value of time, value of traveling time
- Traffic model
- The definition of Transport Network
- Passenger Traffic
- Existing traffic in both road corridors
- 

For both segment Durres–Tirana and Tirana Elbasan, a financial analysis has been considered: traffic diversion, traffic forecast, financial analysis, investment cost, costs of maintenance, financial revenues, and sensitive analysis.

**Table 6 Table 6**  
Classification of alternatives according to travel distance and construction cost

No	Comparing Criteria	Alternative				
		1st	2nd	3rd	4th	5th
1	According travel distance	A	D	B	E	C
2	According construction cost	E	A	C	D	B
	First	5 points				
	Second	4 points				
	Third	3 points				
	Fourth	2 points				
	Fifth	1 points				
<b>Classification</b>						
No	Alternative	Points			Classification	
1	Alternative 'A'	9			1st	
2	Alternative 'B'	4			4th– 5th	
3	Alternative 'C'	4			4th–5th	
4	Alternative 'D'	6			3rd	
5	Alternative 'E'	7			2nd	

## 5 Conclusions

From the above mentioned study we reached an important conclusion to be suggested to the Albanian Government.

For Durres–Tirana segment, based on the financial analysis, the investment is financially viable for a period not less than 35 years. The Government is a very important actor which can guarantee the project scheme. The consultant recommends the involvement of Albanian Government in the expropriation process. Engineer recommends the construction of the Tirana–Vore–Durres Motorway by concession as a project financially viable.

Based on the financial parameters such as the IRR and Net Present Value, the construction of the four lane motorway Tirana–Krraba–Elbasan by concession is not financially viable. The construction of the two lane highway including the tunnel can be financially viable only in the case the Government of Albania partly subsidize the construction of the road infrastructure. Third option is the one in which the state takes the responsibility for the road segment construction instead of the concessionaire who should take the responsibility for the tunnel construction. The tunnel length is 2.5 km.





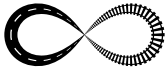

## UNDERSTANDABLE, VISIBLE AND CLEAR INFORMATION TO THE DRIVER – DO WE KNOW HOW TO PROVIDE IT?

**Uroš Brumec, Aleš Merkun, Nina Verzolak Hrabar**

*DRI Investment Management, Company for Development of Infrastructure Ltd., Slovenia*

### Abstract

Participants in road traffic perceive their road and transport environment according to their abilities and motivation. Here, we must not forget that human organism has adapted to certain way of living and to the speed. In the last few decades we have been witnessing a radical progress; life is becoming faster, humans have trouble following this and it is not surprising that many fail - this is known as the human factor.

We are facing an increased drivers' visual information overload of the road space; also with traffic signals, a multitude of important and less important information for the driver. Many times, there is an adverse effect achieved due to the excessive number of traffic signals, their inconsistency and unsystematic installation - the drivers are unable to perceive the whole information or they do not understand it. Consequently, this causes confusion and additional psycho-physical burden. The traffic safety of participants is thus decreased.

Since the driver's cognitive and perceptive abilities are rather limited, he should only be 'burdened' by as many information as are necessary and essential for safe driving. Above all, attention should be paid that the perceived information from the driver is consistent with his expectations, that it draws his attention and can be easily read and understood.

Finally, we should not ignore the fact that people live longer, the elderly are healthier and consequently more active. By this, a proportion of older drivers has been increasing and their psycho-physical abilities decline significantly with age.

*Keywords: human factor, visual information, space perception, traffic safety*

### 1 Perception of traffic signs and road environment

Considering that humans receive about 90% of all information in traffic through eyes, the visual quality of road environment is very important. As human brain has limited capacity for processing the information received, too much distraction or unnecessary information on and alongside the roads overloads drivers processing capacities and abilities to understand the information and act upon it.

Our goal must be (from traffic and environmental point of view) not to overload drivers mental capabilities with too much and/or unnecessary information.



**Figure 1** Information overload of the road space

## 2 4-C's Rule

The road users can not do everything at same time so road engineers must therefore design roads and signage in the way the road users will be informed about what is strictly necessary to them. Information provided along the road must stand out, be legible and understandable. In road engineering we are familiar with 4 sometimes 5 E's: Education, Engineering, Enforcement, Environment and sometimes Emergency services or care. But, when we are dealing with information for road users, we must consider 4 C's: Conspicuous, Clear, Consistent and Credible, regarding the information provided.

### 2.1 Conspicuous

The driver must notice the road layout and signs – it must be conspicuous. Driver must be physically able to see what is coming up, the visible information must be noticeable and eye-catching to encourage the driver to act correspondently to the information provided The objective is to provide noticeable early warning of the need for drivers to be alert to obstructions and/or deviations on the road.



**Figure 2** Conspicuous: Is the approaching sign and work zone obvious, noticeable and eye-catching?

### 2.2 Clear

If we want the driver to act accordantly to the provided information guiding and other instructions must be clear. The driver needs to be absolutely certain about what is required. Signs must be visible from a sufficient distance, regarding approaching speed, so the driver can be able to understand what is required from him.

Human beings are only able to process a limited amount of information so care must be taken not to overload the drivers. Too many signs and/or information will overload the driver's

mental capabilities and will produce a form of 'sign blindness' - driver sees all the information but is unable to process them and act in a safe way.



**Figure 3** Clear: Does the driver know what to do? Which direction? What lane? Are the signs and lane markings correct? Does the driver have all the necessary information? Traffic signs among themselves and with road markings are not consistent.

### 2.3 Consistent



**Figure 4** Consistent: Does the curve warning signs feel like others the driver has encountered in the past (depending on curve geometric design)?

Drivers behave and act in a certain way in accordance with a consistent design of traffic signs and road layout. But if drivers encounter differing standards, layouts and arrangements in different areas they become confused and uncertain how to proceed. This can lead to poor driving and a failure to act in the required way.

The basic rule of having consistency is to provide the user with the correct expectation of what will occur ahead. By using consistent designs, we can assist the drivers in making appropriate and safe decisions.

## 2.4 Credible



**Figure 5** Credible: Does the driver believe that speed reductions are necessary and are believable?

Drivers must believe that what they are told (e.g. dangerous curve ahead) and that the messages they are given are a true representation of what will occur ahead. This involves the credibility or 'believability' of the information provided.

Take a situation where speed limit signs (40 km/h) are generally set up at majority of the exiting ramps of motorway. Because the speed limit is not given accordingly to the road layout (ramp geometric design) the drivers can drive with much higher speed when exiting the motorways. So the next time they are given the same speed limit they do not believe the information (credibility), which may be this time actually crucial for safe driving in the curve or road ahead.

## 3 Common mistakes regarding '4C'

If the information provided to the road users is not what they expect, if the information does not grab their attention, if they cannot read the information, if they can not understand the information, than they are ill-informed. With that, they will become insecure and mislead, with that the chance for making mistakes increases and potential accidents are more likely to occur. Also the road user who gets too much information at the same time, or is constantly bombarded with information, will probably not process the traffic information in the expected way (what we are trying to say to him) or will not see it at all because of other commercial information. So there is a great probability that the driver (because of the visual overload) will choose the wrong information in a critical situation, and this could resolve in an accident. When designing the road, the designer often takes into account the border defined by the project and does not consider the traffic situation outside that border, which often has a signi-

ficant impact on the traffic situation in the overall area. That way we get some very confusing, insufficient or even faulty information to the driver.

Also road operator, to legally-formally protect its responsibility, will set up a line of traffic signs to 'inform' the driver of all sorts of things the driver should be aware of or take special care of. Of course the driver does not understand the information and does not respond correctly, he just takes all the responsibility.



**Figure 6** Misleading information: signs vs. road markings (horizontal line gives the illusion of right-of-way driving strait ahead)



**Figure 7** Information does not grab road users attention (driver does not see the pedestrian crossing, no zebra marking, road layout is not appropriate and the sign is not visible enough)



**Figure 8** The Road user cannot read the information (too much information at once and/or distraction)



Figure 9 The Road user cannot understand the information (contradicting information)



Figure 10 Typical transference of responsibility from road operator to the driver

## 4 How to provide the information using the '4C'

When we are dealing with an existing road or we are designing a new one, we must take into account the 4Cs'. The presumption for a designer and/or road operator, must be a 'safe driver'. So if you have a driving license you must be aware and understand traffic rules and obligations. With that in mind we can reduce the amount of traffic information needed for safe driving.

If the situation on the road is 'normal' than additional information is not necessary. But if we need to give an important information to the driver, than this information must be: Conspicuous, Clear, Consistent and Credible. 4Cs' mean visible and recognizable information from a sufficient distance, so the driver will have enough time to see, understand and (re)act accordantly to the information.

So in other words the information must be visible (must stand out), must be legible (large enough - specially letters, symbols and pictograms), understandable (not confusing) and uniform (it's always the same everywhere).

Especially we must take into consideration the ageing population, the number of older drivers is increasing and they usually drive longer. Symbols on traffic signs are more or less uniform, but we have to be very careful when designing new or uncommon information to the driver. Also we should consider of reviewing the existing letters symbols, to make them more readable and therefore understandable to the user, especially to the ageing population.



Figure 11 Visual information process



Figure 12 Example of letter improvement on traffic signs

## 5 Conclusion

It is crucial, that we understand and start to implement the human factor – knowledge into the road design. The road engineers must provide safe technical elements and provide safe road environment (self explaining road and forgiving road sides).

When choosing the tool to communicate with the driver (road signs and markings), we must understand the visual limitation of the human eye and limitations of ability to process the information (psycho-physical abilities).





Figure 13 'No comment' commercial billboard 'ŠTOF'

## References

- [1] Brumec, U. 2006. Prometna signalizacija in prometna oprema v funkciji cestnega prometa, Graduate work, Ljubljana.
- [2] Brumec, U., Herman, E., Verzolak Hrabar, N., Polic, M. 2010. Road Environment as a Factor of Road Safety – do we understand the concept? V: Zbornik x Medunarodni simpozijum Prevenција saobraćajnih nezgoda na putevima 2010. Novi Sad, 21.- 22. oktober 2010.
- [3] Verzolak Hrabar, N. 2011. Unification of segments of guidance lamellas for state roads, Master of Science Thesis No.: 225, Ljubljana.
- [4] VDOT, Cynthia Brown Microsoft PowerPoint - for public consumption II, Older Driver Initiatives.ppt.
- [5] World Road Association – PIARC, Technical committee C.1 “Safer Road Infrastructure”, WG 4 “Improvements in Safe Working on Roads”, 2011.
- [6] 10 Golden Rules, Rijkswaterstaat, 2008.

## 5 ROAD INFRASTRUCTURE PLANNING



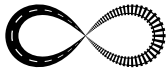

## APPLICATION OF MULTICRITERIA ANALYSIS FOR SELECTION OF ALTERNATIVE IN THE ROAD PROJECTS

Aleksandar Glavinov<sup>1</sup>, Zoran Krakutovski<sup>2</sup>,  
Slobodan Ognjenovic<sup>2</sup>, Katerina Mitkovska–Trendova<sup>1</sup>

*1 University Goce Delcev, Military Academy General Mihailo Apostolski,  
Republic of Macedonia*

*2 University Sts. Cyril and Methodius, Faculty of Civil Engineering Skopje,  
Republic of Macedonia*

### Abstract

The importance and public nature of road infrastructure requires involvement of many stakeholders in the process of decision making in the democratic societies. The usage of Multi-Criteria Analysis (MCA) is a pertinent tool in decision making when some of specific objectives are imperative to achieve. Besides, the road infrastructure is very important for the system of civil protection and defence for all countries. This work shows the methodology for definition of criteria and determination of weight for each criterion. The following six main criteria are assessed: traffic flow, impact of spatial plan, civil engineering criteria, economical and financial criteria, environmental criteria, criteria for defence and system of civil protection. More specific sub-criteria are defined in each group of main criteria. The questionnaire with a list of main and specific criteria is sent to several institutions and experts in the country to give their opinion thereon, or to estimate each main criterion (first step of weighting) as well as to assess each sub-criterion (second step of weighting). The results of the survey concerning measurement of the importance of each criterion are used to develop Multi-Criteria Analysis. The assessment of three variants of road infrastructure is calculated through three methods of MCA: Sum Weight Method (SWM), Analytic Hierarchy Process (AHP) and ELECTRE. The comparison and recommendation for usage of MCA and choice of the calculation method is also provided in this work.

*Keywords: multi-criteria analysis, road infrastructure, criterion, weighting.*

### 1 Introduction

The planning and the execution of the road infrastructure are complex projects which are of interest to many subjects. Specially interesting is the theoretical investigation of decision making in road projects, arrangements of the space for the defense needs and the application of multicriteria analyses in the process of decision making for the road infrastructure projects. This paper deals with the methods of multicriteria decision making as assistance to the 'decision maker' to identify the best agreed solution. In addition the improved techniques to typify the priorities and incorporate them in the decision making analysis has been displayed. Analysis of the road infrastructure has been made and a methodology for multicriteria analysis application in decision making process related to the roads has been suggested.

## 2 Criteria for assessing the conditions of the state road network including the defence needs and the civil protection system

Application of multicriteria analysis as a support in decision making when selecting projects related to the road infrastructure requires identification and consideration of the preferences of the concerned subjects in the decision making process. An assessment of the importance of the criteria in the decision making process for the road net related projects and by considering the defence needs has been made by the use of a questionnaire.

A sample involved in the questionnaire has been taken by the ministries and the independent authorities of the government the highest level being the head of a sector, the higher education institutions, professors, distinguished experts and heads of advisory teams and logistics experts.

The questionnaire has been structured in two parts. The first part represents six basic criteria displayed in table 1.

**Table 1** Basic criteria

Number	BASIC CRITERIA	Mark
1.	Traffic criteria	TC
2.	Spatial criteria	SC
3.	Design – building criteria	DBC
4.	Economic and financing criteria	EFC
5.	Environment related criteria	ERC
6.	Defence related criteria	DRC

The second part defines the subcriteria for each of the abovementioned basic criteria in the questions and the possible measures for them. Four subcriteria have been proposed for the traffic, three for the spatial ones, eight for the economic, four for the building one, six for the environment protection and six defence subcriteria.

Such prepared questions were distributed to the relevant subjects to give weighting coefficient to each criterion and subcriterion. Out of the 50 questionnaires sent, 40 respondents were received (80% respondents).

From the obtained responses and the allocated weighting it could be noticed that they are in accordance with the scope of interest and the subjects' competencies that mark the given criteria in the questionnaire. In order to avoid allocation of 100% coefficient for a single criterion, the methodology for questionnaire filling contains a condition that the maximum allocation for a certain criterion shouldn't surpass 60%. With this limitation each interviewed subject (expert of certain area) besides the mark for the criteria should determine and give a preference for the other criteria from the list.

From the received results, it could be concluded that the highest mark i.e. weighting coefficient, the 40 respondents gave to the fourth criteria i.e. 'the economic and financing criteria' and it is 26.10%, while the lowest weighting coefficient is 'building criteria' and it is 6.20%. These results have been applied into the next applicative example which illustrates the use of obtained data.

### 3 Applicative example

The considered example refers to three variants from a road project and it is necessary to determine the most desired variant solution. Needed data (weighting coefficient) of the criteria and the subcriteria will be taken from the marks given in the conducted questionnaire. For analysis the following methods will be used: Method for full aggregation of the final result which is the

- Weight Sum Method (WSM – Weight Sum Methode);
- Method of analytic hierarchy process (AHP – Analytic Hierarchy Process) and
- Method of partial aggregation or method ELECTRE 1.

**Table 2** Multicriteria matrix

VARIANTS	Criteria						
	TC	SC	DBC		EFC	ERC	DRC
	Traffic intensity	Maximum skew/slope of grade level	Investment expenses	Exploitation expenses	Contamination of the atmosphere	Linking the populated places	Linking the defence directions
	T1 (AADT)	S1 (%)	DB1 (103 €)	DB2 (103 €)	EF1 (descriptive)	ER1 (descriptive)	D1 (descriptive)
Variant road 1	6210	3,010%	67,2	601,2	90%	80%	100%
Variant road 2	6910	3,200%	70,3	572,3	80%	100%	90%
Variant road 3	7020	3,400%	68,1	594,7	100%	90%	80%
Weighting coefficient	0,21	0,06	DB1 = 0,17 0,09	DB2 = 0,26	0,13	0,12	0,22

Characteristics of the three variants for which a comparison of seven criteria should be conducted and a mark should be allocated for selection of an investment project are displayed in the table 2.

Total expenses in the exploitation are a sum of exploitation expenses of the vehicles, maintenance expenses, traffic accidents expenses and expenses from the time of traveling, discounted to the first year of exploitation. Weighting coefficients are obtained from the questionnaire conducted as part of this work.

#### 3.1 Weight Sum Method (WSM)

Applied method for comparing the variants is with a sum of weighting values of the separate criteria, i.e. by the method of a global sum. Since the values of each criteria are expressed in the natural measuring units or descriptively and differ regarding the criteria and in order to make the comparisons, the values of each criterion should be brought to a non dimensional size and to establish a non dimensional matrix, i.e. to start the procedures known as normalization of the measures of the criteria. This normalization is carried out with different attributes assigned for each criteria and each variant in a comparable size and at the same time the preference for each criteria is determined as to whether the most desired solution is the highest or lowest measuring value (Table 3).

**Table 3** Non dimensional matrix according to WSM

Variant	Criteria						
	T1 (+)	S1 (-)	DB1 (-)	DB2 (-)	EF1 (+)	ER1 (+)	D1 (+)
1	0.8846	1	1	0.9519	0.900	0.800	1
2	0.9843	0.9406	0.9559	1	0.800	1	0.900
3	1	0.8853	0.9868	0.9623	1	0.900	0.800
Weight	0.21	0.06	0.17	0.09	0.13	0.12	0.22

Determination of the global result for each of the three variants is as follows:

- Variant one:  $\Sigma W = 0.8846 \times 0.21 + 1.00 \times 0.06 + 1.00 \times 0.17 + 0.9519 \times 0.09 + 0.9000 \times 0.13 + 0.8000 \times 0.12 + 1.00 \times 0.22 = 0.937$
- Variant two:  $\Sigma W = 0.9843 \times 0.21 + 0.9406 \times 0.06 + 0.9559 \times 0.17 + 1.00 \times 0.09 + 0.800 \times 0.13 + 1 \times 0.12 + 0.900 \times 0.22 = 0.934$
- Variant three:  $\Sigma W = 1.00 \times 0.21 + 0.8853 \times 0.06 + 0.9868 \times 0.17 + 0.9623 \times 0.09 + 1.00 \times 0.13 + 0.90 \times 0.12 + 0.800 \times 0.22 = 0.931$

According to this calculation, the best valued variant is the variant B1, although the results from the calculations show a small difference in the summed result.

### 3.2 Analytic Hierarchy Process (AHP)

Analytic Hierarchy Process (AHP) is a method of multicriteria analysis which enables modelling of complex problems in the hierarchical structure which represents the relations among the criteria, subcriteria and possible variants.

With this method, the weighting coefficients are measured and allocated as ratio among the criteria and not like assigned ones, i.e. assessed weighting coefficient for each criteria. AHP is based on three basic principles: decomposition, comparative assessment or synthesis of priorities. Decomposition refers to establishing hierarchical branching. The principle of comparative assessment refers to the comparison of pairs of all possible combinations. Principle of synthesis comprises of multiplication of local priorities in a group with global priority.

The application of the AHP method over an example will be represented for selection of one of the three variants of road with criteria out of which the economic criteria have been divided in two subcriteria or there are totally seven criteria according to which the variants are valued. The best valued variant according to the AHP method has been shown in the table 8.

According to this calculation, the best valued variant is also variant B1. Only the difference in the obtained results is more evident than in the previous method SWM.

**Table 4** Grades used in mutual comparison in AHP method

Intensity (significance)	Definition	Explanation
1	Identical significance	Two variants are equally significant in relation to the goal
3	Medium significance	More desired variant
5	Important significance	Strongly desired variant
7	Very important significance	Absolutely confirmed more desired variant
9	Extreme significance	Extreme more desired variant with highest confirmation

Intensity of 2,4,6 and 8 can also be mentioned (Source: T.L. Saaty, The Analytic Hierarchy Process, McGraw-Hill, (1980))

**Table 5** Weighting coefficient at a criteria level according to the AHP method

Criteria comparison	(TC)	(SC)	(DBC)	(EFC)	(ERC)	(DRC)	Suma	medium value
TC	1.00	6.00	0.50	4.00	3.00	2.00	16.50	0.251
SC	0.17	1.00	0.14	0.33	0.50	0.20	2.34	0.036
DBC	2.00	7.00	1.00	5.00	4.00	3.00	22.00	0.334
EFC	0.25	3.00	0.20	1.00	2.00	0.25	6.70	0.102
ERC	0.33	2.00	0.25	0.50	1.00	0.33	4.42	0.067
DRC	0.50	5.00	0.33	4.00	3.00	1.00	13.83	0.210
	4.25	24.00	2.43	14.83	13.50	6.78	65.79	1.00

**Table 6** Normalization of weight coefficient at a criterial level according to the AHP method

Criteria comparison	(TC)	(SC)	(DBC)	(EFC)	(ERC)	(DRC)	Suma	Weight coefficient
TC	0.24	0.25	0.21	0.27	0.22	0.29	1.48	0.246
SC	0.04	0.04	0.06	0.02	0.04	0.03	0.23	0.038
DBC	0.47	0.29	0.41	0.34	0.30	0.44	2.25	0.375
EFC	0.06	0.13	0.08	0.07	0.15	0.04	0.52	0.086
ERC	0.08	0.08	0.10	0.03	0.07	0.05	0.42	0.070
DRC	0.12	0.21	0.14	0.27	0.22	0.15	1.10	0.184
	1.00	1.00	1.00	1.00	1.00	1.00	6.00	1.000



**Table 7** Calculation with combined pondering with weight coefficient according to the AHP method

Weight 1	0.246	0.038	0.375	0.375	0.086	0.070	0.184
	(TC)	(SC)	(DBC)		(EFC)	(ERC)	(DRC)
Weight 2	-	-	0.67	0.33	-	-	-
	AADT	Skew/slope grade level	Investment expenses	Exploataation expenses	Atmosphere contamination	Linking populated places	Linking defence directions
B1	0.11	0.54	0.72	0.11	0.30	0.14	0.54
B2	0.26	0.30	0.08	0.63	0.16	0.62	0.30
B3	0.63	0.16	0.19	0.26	0.54	0.24	0.16

Weight 1	0.246	0.038	0.375	0.375	0.086	0.070	0.184
	(TC)	(SC)	(DBC)		(EFC)	(ERC)	(DRC)
Weight 2	-	-	0.67	0.33	-	-	-
	ПТДС	Skew/slope grade level	Investment expenses	Exploataation expenses	Atmosphere contamination	Linking populated places	Linking defence directions
B1	0.03	0.02	0.18	0.01	0.03	0.01	0.10
B2	0.06	0.01	0.02	0.08	0.01	0.04	0.05
B3	0.16	0.01	0.05	0.03	0.05	0.02	0.03

**Table 8** The best valued variant according to the AHP method

FINAL RESULT	RANKING	
B1	0.38	1
B2	0.29	3
B3	0.34	2
	1.00	

### 3.3 ELECTRE 1 – model for decision making with sequential classification

ELECTRE 1 (Elimination Et Choix Traduisant la Réalité) is a method which enables to lead to subject which makes a decision in its choice of one possible activity (a) in the set A of activities knowing that many criteria of preferences should be considered from non aggregated characteristics of the possible activities. ELECTRE 1 is a method of divide in the presence of many criteria. More precisely, it is a method which enables bipartition in A, between the selected activity (i) and the other activities A-1 which are eliminated. So, this method uses the technique of comparison of each variant. By applying this variant the results is that the variant B1 dominates the other two variants and is the best valued variant.

## 4 Conclusion

Previously pointed methods for road infrastructure projects' assessment are applicable and should be part of a process for variants assesment. It is important to include all the interested subjects from the project in the project monitoring body which by its participation will contribute to the assesment of the most desired project. This research has considered a criterion which assesses the variances from the aspect of the defence needs.

The results show that the obtained global results from the evaluation of the three variances are very close. Therefore, analysis of the results' sensitivity when the input parameter for the variant attributes change should be made. One probability approach to determine the input parameters would be more objectively acceptable concept for multicriteria analysis application.

## References

- [1] Koski, J (1985), 'Defectiveness of weighting method in multicriterion optimization of structures', *Communication in Applied Numerical Methods*, Vol. 1, Issue 6, pp. 333-337
- [2] Saaty, T. L. (2006): 'Fundamentals of Decision Making and Priority Theory with he Analytic Hierarchy Process', Vol VI of the AHP Series, RWS Publications, 2006.
- [3] Roy, B. and Figueira J., (1998): 'Détermination des poids des critères dans les methods de type ELECTRE avec la technique de Simos revise', Université de Paris-Dauphine, Doc. du LAMSADE n°109.
- [4] Kim IY, de Weck OL (2005), Adaptive weighted sum method for bi-objective optimization: Pareto front generation, *Struct MULTidiscipl Optim* 29: 149-158
- [5] Saaty, T. L., (2001): 'Decision Making For Leaders: The Analythic Hierarchy Process for Decisions in a Complex World'. RWS publications, Pittsburgh. 1990, new-edition.
- [6] Roy, B. (1996): 'Les logiques compensatoires et les autres', in: *Proceedings des 44èmes Journées du Groupe de Travail Européen Aide Multicritère à la Décision*, Bruxelles, Belgique.
- [7] Roy, B., (1990): 'The out ranking approach and the found ations of ELECTRE methods'. In C.A. Banae Costa, editor, *Readings in Multiple Criteria Decision Aid*, pages 155-183. Springer-Verlag, Berlin.



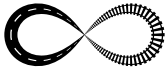

## STRATEGIC TRANSPORT INFRASTRUCTURE IN SOUTH EAST EUROPE: PLANNING EXPERIENCE AND PERSPECTIVES IN THE CONTEXT OF THE EUROPEAN TRANSPORT POLICY

**Marios Miltiadou, Socrates Basbas, George Mintsis, Christos Taxiltaris, Anthi Tsakiropoulou**  
*Aristotle University of Thessaloniki, Faculty of Rural and Surveying Engineering, Dept. of Transportation and Hydraulic Engineering, Greece*

### Abstract

South East Europe (SEE) is a region of high importance for the European Union (EU). Especially concerning Transport, this importance accrues from the fact that this region is a part of the European continent, but at the same time it is a discontinuity zone of the Trans-European Transport Networks (TEN-T).

The European Transport Strategy for the non-EU regions has been expressed in the '90s through the Pan-European Corridors (PECs) and Areas (PETRAs) concept, but moreover, in this particular region it was more intensively expressed after 2001, with the definition of the SEE Strategic Network and of the SEE Core Transport Network, in view of the EU enlargements, which would cause the incorporation of entire PECs or parts of them into the TEN-T. Then, the European Commission (EC) initiated the revision of the PECs' concept, proposing five Priority Axes, and among them the South Eastern Axis that covers the SEE region, the Caucasus, Turkey, Middle East and Egypt.

In this aspect, taking into consideration the development already made on the networks of the acceding countries, a new orientation for extension of the transport networks for a wider Europe has been initiated. Especially for the development of the South Eastern Axis, with the aim to boost the development of transport infrastructures in the SEE region, the PECs' structures, Transport Ministries and the SEE Transport Observatory (SEETO) are engaged in the SEE Transport Axis Cooperation (SEETAC), a project funded by the SEE Trans-National Programme. In this paper, an overview of the general framework and the followed methodologies for priority project definition and promotion is presented, together with intermediate results of the analysis of the existing situation carried out within the SEETAC project. Perspectives for development and priority projects are presented based on these results, other studies and the TEN-T framework, which is currently under revision.

*Keywords: Infrastructure Projects, European Transport Strategy*

### 1 Introduction

This paper presents the implementation of the European Transport Strategy in the SEE and especially in the so called 'Western Balkans'. The Western Balkans (WB), regardless of the different stage of integration of the various countries, is considered as a region of special and high importance for the EU, being a part of the European continent with clear EU orientation. Therefore, the extension of the major trans-European axes to these neighbouring countries is essential.

The first aim of the paper is to present the general transport strategy for infrastructure development for the non-EU regions, with special emphasis on the strategic networks in SEE. More-

over, this paper focuses on the perspectives in the context of the current European Transport Policy, the revised framework for transport infrastructure planning after the EU enlargements of 2004 and 2007 and the most recent proposal for the revision of the TEN-T Guidelines in 2011.

Furthermore, this paper aims to present the followed methodologies for priority project definition and promotion after more than ten years of planning experience in the framework of the European Transport Strategy, together with the results of the analysis of the existing and future situation in the SEE region carried out within the SEETAC project and other relevant studies. The methodology to approach the aim of the paper consists of: a) the presentation of the PECs in the region and the SEE Strategic and Core Networks; b) the presentation of the revised framework for transport infrastructure planning in neighbouring countries/regions after the EU enlargement; c) the presentation of results of the analysis of the existing situation concerning the supply and the demand in the SEE region (carried out within the SEETAC project); and d) the formulation of comments and conclusions, for the strategic transport infrastructure planning and the project priorities definition in the SEE region.

## 2 Corridors in the region – SEE Strategic and Core Networks

In the '90s, especially after the Maastricht Treaty, the EC carried out extensive planning exercises to define and promote the TEN-T for the Member States and the neighbouring countries. Even before the TEN-T guidelines definition in 1996, it was recognized that there is a need for further planning in SEE, in order to involve the non-EU regions. In this aspect, at the Pan-European Transport Conferences of Crete (1994) and Helsinki (1997), the Pan-European Corridors (PECs) and Areas (PETRAS) for the non-EU European territories were defined.

The “grid” of PECs in the SEE region consists of PECs IV (North-Southeast), V (West-East), VII (the Danube Inland Waterway), VIII (West-East), IX (North-East) and X (Northwest-Southeast). Additionally, three out of the four PETRAS are sited in SEE: the Adriatic – Ionian Seas, the Mediterranean Basin and the Black Sea Basin. For the documentation and prioritisation of projects, as well as for the examination of the development potential of the transport sector in general and especially PECs’ infrastructure, various regional planning exercises, strategic studies and inventories were elaborated.

More specifically, one of the extensive planning exercises, in order to define the TEN-T for the Member States and the accession countries, was the Transport Infrastructure Needs Assessment (TINA). Based on the PECs, TINA contributed to the coordination of the infrastructure investment plans of the eleven (then) acceding countries with those of the EU member states, in view of the extension of the TEN-T to the enlarged EU. There was obviously a gap on the European map and rationally it was then recognized, that there was also need for further planning to involve the five (then) countries of the WB participating in the Stabilisation and Association Process.

In these terms, the European Transport Policy was further enhanced, on the basis of the already established PECs, with the SEE Strategic Network definition in 2001 [1]. Two strategic studies, similar to TINA, were elaborated immediately after: the Transport Infrastructure Regional Study (TIRS) [2] and the Regional Balkans Infrastructure Study (REBIS) [3], and the SEE Core Transport Network was defined (nowadays called 'SEE Comprehensive Network', in order to avoid misunderstanding with the term 'Core' used in the current TEN-T revision process), as well as lists of priority projects.

### 3 Enlargement and revised framework for transport infrastructure planning in EU neighbouring countries and regions

In view of the EU enlargements, which would lead to the incorporation of entire PECs or parts of them into the TEN-T, the EC initiated the revision of the PECs' concept. The 14 Priority Projects (PP) defined in 1996 became 30 in 2004, for the enlarged EU. Sections of the PP 6 (Railway axis Lyon - Trieste - Divača/ Koper - Divača - Ljubljana - Budapest - Ukrainian border), PP 7 (Motorway axis Igoumenitsa/ Patras - Athens - Sofia - Budapest), PP 18 (Waterway axis Rhine/ Meuse - Main - Danube) and PP 22 (Railway axis Athens - Sofia - Budapest - Wien - Praha - Nürnberg/ Dresden) coincide with the Railway PEC V, Road PEC IV, Inland Waterway PEC VII and Railway PEC IV respectively.

At Pan-European level, the EC [4] proposed five 'Priority Axes' (Sea Motorways, Northern Axis, Central Axis, South Eastern Axis and South Western Axis), which would contribute to the promotion of international exchanges, trade and traffic between the EU and its neighbours, with additional branches (with lower traffic volumes) for regional cooperation enhancement and integration in the long term. The 'South-Eastern Axis' in the SEE region is actually the network of the existing PECs; although some parts of them are excluded (Branches B of PEC V and D of PEC X, plus PECs IV and IX, which are now parts of the TEN-T). This Axis was actually the inspiration of the SEETAC establishment.

Cooperation in the transport field and the extension of the *Acquis Communautaire* to the new EU member states, the candidate and the potential candidate countries of the SEE region is more advanced than for the other partner countries of the EU that are included in the European Neighbourhood Policy. Therefore, the EC suggests that cooperation in the WB should focus on the SEE Core Network development and encourages the countries to speed up alignment of their national legislation with the *Acquis Communautaire* on transport and relevant thematic areas, in order to fully benefit from the accession framework. The EC and the countries of the region are for years now negotiating a Treaty for the establishment of a Transport Community in SEE, targeting at the establishment of an integrated market for infrastructure and land, inland waterways and maritime transport and of course the adjustment of the relevant legislation in this region. However, due to political reasons the Treaty has not yet been signed.

In the Member States the TEN-T Programme consists of projects (defined as studies or works), whose ultimate purpose is to ensure the cohesion, interconnection and interoperability of the TEN-T as well as the access to it. The Priority Projects and other horizontal priorities, as a whole, are established to concentrate on Pan-European integration and development and aim to establish and develop the key links and interconnections needed to eliminate existing bottlenecks to mobility, fill in missing sections and complete the main routes, especially their cross-border sections, overcome natural barriers and improve interoperability on major routes.

In late 2011, the EC adopted a proposal to transform the existing patchwork of European roads, railways, airports and canals into a unified TEN-T and, among others, to promote projects of mutual interest, including extensions to the neighbouring countries and regions [5]. A dual layer TEN-T is proposed: the 'Comprehensive' and the 'Core'. Especially the second is envisaged to improve connections between different modes of transport and provide adequate connections to neighbouring countries, ensuring geographical coverage.

More specifically, the projects of mutual interest aim to connect the TEN-T with the networks of third countries (covered by the Enlargement Policy, the European Neighbourhood Policy, the European Economic Area and the European Free Trade Association) and seek to connect the Core TEN-T at border crossing points, ensure the connection between the Core TEN-T and the networks of the third countries (like the SEE Core Network), complete the transport infrastructure in third countries which serve as links between parts of the Core TEN-T and implement traffic management systems in those countries. Such projects shall enhance the capacity and utility of networks located in the SEE countries.

## 4 SEETAC interim results for the existing situation

### 4.1 SEETAC content

The SEETAC project main technical activities concern: a) the establishment of a detailed and harmonised database for the existing and future situation of the SEE transport infrastructure and b) the development of a transport model for the simulation and assessment of the existing situation and the examination of development scenarios (demography, economy, trade, new projects implementation) for the future (target year 2030) and their impact on transport operations and the environment.

The reference network (Figure 1) consists of the strategic infrastructure (TEN-T, PECs and SEE Core Network – consisted of PECs and important routes in the WB), as well as some other sections useful for modelling purposes, and concerns roads, railway lines, inland waterways and their interconnection points with the ports and airports in the region.



**Figure 1** SEETAC study Road (left) and Railway (right) Networks [6]

The simulated road network consists of 373 links with total length of 23.920km and the railway network of 301 links with length of 19.085km in total.

For these networks a very detailed survey was performed in order to collect data for the physical (geometrical) and operational characteristics of each one of the networks' links and nodes. This survey allowed the establishment of the SEETAC study network database and the construction of the SEETAC transport model with appropriate geo-reference and assignment of the appropriate attributes to its components.

Through the transport model it is possible to have various functions for the assessment of the network, e.g. the identification of main trips generators and attractors, saturated links and nodes, corridors and nodes of national (but mostly regional/international) importance. Furthermore, the model shall test the impact of the priority projects implementation on the traffic assignment on the network under study, for the target year of the traffic forecast, year 2030.

For the examination of the future situation of the infrastructure (supply), a data collection is under elaboration concerning projects under implementation or underway for implementation (secured financing), as well as on projects included in the national transport plans and which are also part of the TEN-T and SEETO planning.

## 4.2 Results of the inventory on existing situation of Roads and Railways

A very detailed database has been established up today [6], which refers to the existing situation of the transport network (geometrical/ physical and operational characteristics) of the various transport modes, based on the information provided to the EC (DG Mobility and Transport) by the EU Member States and to the SEETO by the WB countries, for TENtec and SEETIS systems, respectively.

The total length of PECs in the region under study is 9.594km of roads and 10.530km of railway lines. From the initial processing of this database and per PEC, it emerges that the infrastructures on the main PECs running through the region are more or less developed: 53,1% of the roads are with 2 or more lanes per direction, 51,4% of the PECs (existing) railway lines are with double tracks and 83,7% of the PECs railway lines are electrified.

Regarding the road network, the length of motorways and expressways (2 or more lanes per direction) on PEC X represents 72,3% of its total length and on PEC V represent 60,8% of its total length (Figure 2).

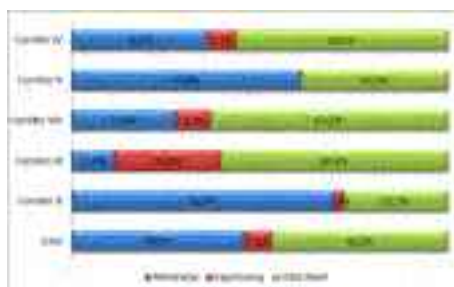

Figure 2 Typology of PECs Roads in SEE (% of the total length).

Regarding the railway network (Figure 3), the length of double tracks on PEC IV represent 64,7% of its total length, on PEC V represent 52,6% of its total length and on PEC VIII 50,7% of its total (constructed) length.

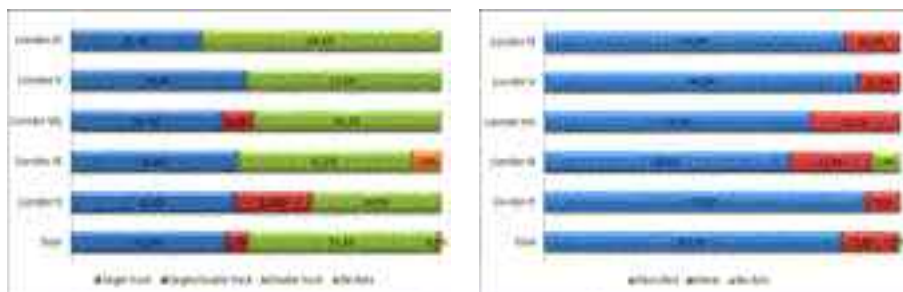

Figure 3 Typology of PECs Railway Lines in SEE (% of the total length)

Furthermore, through the transport model (after trips assignment on the network and the calibration to the observed traffic), traffic and capacity analyses have been performed, through the assessment of the flows over capacity ratios for each road and railway links of the network. The results of these analyses are depicted in Figures 4 and 5, respectively for the road and the railway links.

It can be observed that the biggest share of transport flows is concentrated on the PECs running through the region: On the road network on PECs IV, v and x (and less on PECs VIII and IX), and on the railway network on PECs IV, v and x. Saturation problems appear only at road



sections around important cities of the region (Salzburg – Innsbruck, Milan, Bucharest and Sofia) and on railway lines on the Austrian network, in Slovakia (Bratislava – Gyor), southwest of Ljubljana on PEC V, and on PEC IV, mainly between Plovdiv and Haskovo in Bulgaria.



Figure 4 Volume over Capacity ratio on SEETAC study Road Network [7]



Figure 5 Volume over Capacity ratio on SEETAC study Railway network [7]

### 4.3 Future transport demand in SEE

Concerning the future demand, the scenarios development within SEETAC are under formulation, so there aren't any results for the time being. However, there are other studies with reference to this region, the EUN STAT [8] and the TEN-CONNECT [9].

The first one concerned the freight traffic flows forecast between the EU and the neighbouring countries and regarding the SEE region it concluded that in the future (target year of the forecast 2020) the freight traffic flows will be concentrated on the road corridors between Turkey – Bulgaria – Western Balkans – Germany/ Northern Italy and Bulgaria – Romania – Russia and on the railway corridor between Bulgaria – Romania – Ukraine and Russia.

The second forecast, not only dedicated to freight, concluded that on the SEE road network the PECs with the biggest flows are PEC x (Main Axis from Austria to Belgrade and Nis and Branch c to Sofia) and PEC IV from Sofia to Istanbul. The same applies for rail passenger traffic and to some extent for rail freight traffic, where PEC IV is more loaded on its parts in Romania and its eastern part in Bulgaria near the border with Turkey, and also on PEC IX south of Bucharest.

## 5 Transport project prioritisation in SEE

### 5.1 Prioritisation in previous strategic exercises

Projects are placed among national, regional and international (Pan-European) policies, and therefore in a 'pool' of projects, out of which, usually through Multi-Criteria Analyses (MCA), it results the prioritization of implementation of the most urgent projects.

Therefore, the strategic planning at Pan-European level, dealt with the definition of the most urgent and with international impact projects. According to the TEN-T first guidelines (1996), the processing for the formulation of project proposals for financing focused in three terms: 'projects of common interest', 'bottlenecks' and 'missing links'.

Earlier (1993-1994), for the wider European Network, the Economic Commission for Europe of the United Nations (UNECE) and the European Council of Ministers for Transport (ECMT) worked on the methodology for defining common criteria for the identifying bottlenecks and missing links. On the definition of the term 'bottleneck' worked later the studies TEN-NAxis [10] and TEN-CONNECT assigned by the EC, whilst in the mean time the HCM and the UIC guidelines were respectively the basic tools for road and railway infrastructure capacity assessment.

In the very beginning the priorities had been set for some of the PECs by their structures and for the TEN-T through their initial definition (14 priority projects), and later on for the SEE by the general guidelines of the EC strategic guidelines of 2001.

On the basis of these EC guidelines, each of the strategic exercises elaborated for the transport infrastructure development in SEE included methodologies for prioritising the projects with major importance for the region.

Especially for the wider SEE region (WB, Romania and Bulgaria), the TIRS was based on the ECMT methodology and developed a weighted MCA to assess the potential projects, according to two main groups of criteria, i.e. the socioeconomic return on investment and the functionality and coherency of the network.

On the same direction, the REBIS developed a weighted MCA with six major criteria categories, but for a more limited network (SEE Core Network): economic appraisal, financial viability environmental effects, functionality and coherency of the network, readiness of the authority to implement a project and speed of implementation.

For the same network, SEETO consultants [11] in 2006 defined the criteria for prioritising projects when preparing the Multi-Annual Plans for the realisation of the SEE Core Network (defined through the REBIS). It categorised the criteria to five groups concerning regional interest, economic and development impact, financial sustainability, environmental and social impact and technical standards.

These MCA methodologies are apparently valuable in the process of the SEE transport network development. However, there are criteria which are more or less linked to the political component of a project, i.e. the national priorities but also the overall EU transport strategy (PECs). In other words, between the projects of the TIRS network, it was obvious that the projects on the PECs in the region would be prioritised. Firstly because they belong to PECs, secondly because they are already prioritised by the national governments (as parts of the PECs and thus as easier to secure funds) and finally because the demand in the region is concentrated on these PECs. So it was obvious that they meet the criteria of functionality and coherence of the network, the regional importance and the importance for international transport.

## 5.2 Project prioritisation in SEETAC

During the elaboration of the SEETAC, it was initially planned to prioritise projects following a detailed MCA, similar to those applied in the aforementioned exercises. A detailed methodology was presented to the project partnership and the EC, but it was decided that no other priorities than those already defined by the SEETO and the EC should be defined.

Therefore, the prioritisation that would emerge from this project should be to define priorities between priorities, i.e. to define the most urgent and mature projects for realisation, which should meet the several criteria (planning, financial and technical) adjusted to the recommendations of EC proposal for the new TEN-T Guidelines: a) belong to the EU proposed Core or Comprehensive TEN-T or the SEE Comprehensive Network, b) provide link between these networks, mainly at border crossing points, c) ensure connection between the Core TEN-T and the transport networks of third countries, d) facilitate maritime transport by providing links to main ports, e) serve the majority of international transport flows, f) ensure and promote interoperability and multimodality, g) ensure financial and economic sustainability, h) minimise investment, maintenance and operational costs and environmental impact.

The TEN-T Regulation is under adoption (co-decision procedure), and the countries of the SEETAC partnership should, through their unified exercise, contribute to the finalisation of the new TEN-T Guidelines. The assessment of the network in the present and future situation contributes to the redefinition of the critical routes on the SEE transport network and the investment needs for development. The results of this assessment will be presented in a dedicated Ministerial Meeting of the SEETAC partnership and an Infrastructure Forum in May 2012 in Athens, with the presence of the EU instruments, the International Financial Institutions and various relevant stakeholders from the Europe and the SEE region.

## 6 Conclusions and perspectives for the SEE Transport Network

From the topological consideration of the Pan-European Networks according to Bunge (1962) and according to the networks attributes that Dupuy (1985) and Chesnais (1982) later defined, it emerges that it is a network characterised by anisotropy, but has high density (networks length per surface unit that they serve), multiplicity and high connectivity capacity of nodes in Western Europe, in contrast to their regional development in SEE. Additionally in the Western Europe we can observe homogeneous and exclusive sub-systems (high speed railway networks TGV/LGV, aviation networks, conventional railway networks and closed motorways' networks), which are adequately interconnected, with elements of interoperability and intermodality [12].

On the contrary, on the SEE network, there is high heterogeneity, which, combined with the physical barriers, the political instability and the various institutional or technical barriers at borders, creates a complex area for transport. In this area there should be developed multi-modal and efficient transport systems.

Obviously, the SEE transport infrastructure needs further development for the connectivity and accessibility of the countries in the region, apart from the general aim to serve the needs for economic, social and territorial cohesion.

The transport networks in SEE, defined through the various planning exercises briefly described in this paper, are not arbitrary. They are pre-existing, historical networks, a priori strategic for the countries concerned, which have been adequately developed in the past, but due to economic reasons have been neglected and did not manage to follow the development achieved in the EU countries, so they lag behind the EU standards.

Therefore, despite the scarcity of funds, the development of these infrastructures is one-way road. The discussion in the process of the new TEN-T regulation definition includes firstly the inclusion of the SEE strategic network in the Comprehensive TEN-T (which in extension would mean inclusion of parts of it in the Core TEN-T upon accession of a country in the EU, i.e. Croatia in 2013) and secondly, the provision of the possibility of financing the development of this network through the new financial mechanisms (Connecting Europe Facility and IPA II) for the TEN-T implementation in the framework of EU 2020 Strategy.

Therefore, the challenge for the countries in the region and the cooperation frameworks is to align the priority projects with the projects implemented or underway in the EU neighbouring countries, in order to secure the anticipated transnational impact of the projects, the consecutiveness of the networks and therefore to maximise the added value for the EU.

## References

- [1] European Commission DG for Energy and Transport, DG for External Relations and EuropeAid Cooperation Office: Transport and Energy Infrastructure in South East Europe, 2001.
- [2] LOUIS BERGER S.A.: Transport Infrastructure Regional Study (TIRS) in the Balkans, 2002.
- [3] COWI: Regional Balkans Infrastructure Study (REBIS), 2003.
- [4] European Commission: Extension of the major Trans-European Transport axes to the neighbouring countries – Guidelines for transport in Europe and neighbouring regions, COM (2007) 32 final, 2007.
- [5] European Commission: Proposal for a Regulation of the European Parliament and of the Council on Union guidelines for the development of the trans-European transport network, COM (2011) 650/2, 2011.
- [6] Central European Initiative – Sistemi Operativi: SEETAC WP3 Interim Report, 2012.
- [7] EURAC – CSST: SEETAC Modelling Functions and Results, WP4 presentation in 8th Project Meeting, Belgrade, 2012.
- [8] NEA Transport research and training: Scenarios, traffic forecasts and analysis of traffic flows including countries neighbouring the European Union (EUN STAT), 2005.
- [9] Tetraplan A/S, Traffic flow: Scenario, Traffic Forecast and Analysis of Traffic on the TEN-T, Taking into Consideration the External Dimension of the Union (TEN-CONNECT), 2009.
- [10] WSP Finland Ltd, The Northern Transport Axis Pilot for the analytical support framework to monitor the implementation of the infrastructure and “soft” measures proposed by the High Level Group (TEN-NAxis), 2007.
- [11] GOPA – TRADEMCO: South East Europe Transport Observatory (SEETO), Technical Note 3, Multi-Annual Plan for the Development of the Core Regional Transport Network, 2006.
- [12] Miltiadou M.: Tools for the effective management and the documentation of the priorities for the development of multimodal transport infrastructures. The case of Pan-European Corridor x - PhD Thesis, 2012.



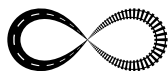

## HIGHWAY A8, SECTION ROGOVIĆI–MATULJI, INFLUENCE OF GENERAL PUBLIC ON DESIGN SOLUTIONS

Nebojša Opačić, Tomislav Kraljić

*Hidroelektra–projekt d.o.o., Croatia*

### Abstract

Despite the fact that the initiative to build a modern road that will connect Istra with rest of Croatia dates back to 1968, Rogovići–Matulji section was opened much later, in the period from 1981 to 1998, and with only one carriageway. In 2008, simultaneously with the start of construction phase 2A on section from Kanfanar to Rogovići, preparations for construction of dual carriageway road on Rogovići–Matulji section also began.

With some deviations to improve design elements, preliminary solution of this 46.3km long section was designed in accordance with the existing carriageway to avoid devastation of residential buildings in the highway corridor wherever it was possible. Basic design speed is 100km/h, but because of mountain terrain and dense built–up area at some parts of the route it was reduced down to 80km/h. In retrospect, 9 junctions, 8 overpasses, 22 underpasses, 4 tunnels (3 previously constructed, and approx. 5660m long 2nd tube of 'Učka' tunnel designed on the north side of the existing one), 15 viaducts, 2 bridges, 8 pedestrian crossings and 2 B–type service areas are anticipated on Rogovići–Matulji section of highway A8.

Environmental impact study was made on basis of the preliminary solution, and in June 2010 it was submitted to the Ministry for environmental impact assessment. First advisory committee conference was held in November 2010, while the public discussion was carried out in the spring of 2011. Public viewings of the Study in Pazin, Opatija and Matulji had high attendance, with a large number of public complaints.

After consultations with local authority, investor and concessionaire officials, and taking into consideration the complaints from general public, preliminary design changes were made so that the highway can 'serve the public' in genuine sense of the word.

*Keywords: highway design, environmental impact assessment, preliminary solution, dual carriageway, improvements*

### 1 Introduction

In 1968 Croatian parliament made a decision that it is of utmost importance to build a modern road to connect Istria with Rijeka and the rest of Croatia. This started the construction of Istrian γ, which today, nearly 50 years later, is nearing its end. From the very beginning, emphasis was put on the biggest and most demanding road object, 'Učka' tunnel. The tunnel was opened on September 27th, 1981, and this successfully removed the biggest obstacle to connect Istria and the rest of the country. Along with the construction of the 'Učka' tunnel, 24 km section from Matulji to Lupoglav was completed.



**Figure 1** Sections of Istrian Y and construction phases

The final corridor of Istrian Y was set in 1983, when the connection between the eastern and western leg was moved from 'Baderna' to 'Kanfanar' junction. In the first construction phase, Istrian Y was built as a two lane, single carriageway road. Sections of the road were opened from 1981 to 2006. In 1995 Bina–Istra was created, as the first concession company for highways in Croatia. Concession agreement was signed for a period of 32 years. Based on it, final construction of the first carriageway began, and after completing the section to Pula in 2006, second carriageway designing and construction took place. Section Kanfanar–Pula, was opened in 2010, and in 2011 sections Umag–Kanfanar and Kanfanar–Rogovići were also opened as dual carriageway roads. This only left the section from Rogovići to Matulji as a single carriageway road. Its upgrade started with drafting of the preliminary solution in 2008, as a base for Environmental Impact Study.

## 2 Preliminary solution of Rogovići – Matulji section

### 2.1 Road

Preliminary solution of this section was designed in accordance with the existing B8 road, which is also the basis for the highway corridor in spatial planning documents. Existing road alignment was reconstructed in some parts of the section to improve design elements and decrease influence on residential areas.

#### 2.1.1 Traffic

Traffic load analysis showed the AADT of 8259 vehicles, and ASDT of 11673 vehicles with stagnation in traffic increase in the last year of monitoring, unlike the previous years. From this data it is clear that traffic increase for the year 2000 predicted in the economic analysis before the first 'Učka' tunnel tube construction (AADT of 13800 vehicles) was incorrect.

#### 2.1.2 Technical elements

Primary design speed on Rogovići–Matulji section of highway A8 is 100 km/h, with some exceptions. On highway section from km 38+000 to km 46+340 ('Matulji 2') design speed is 80 km/h, because of mountain terrain and high concentration of residential buildings in the highway corridor. Because of this, minimum horizontal radius is 250m.

**Table 1** Technical elements used during highway A8 design

minimum horizontal radius	350m(exc. 250m)
maximum slope level	4.91%
lane width (traffic/emergency)	3.5/2.5m
median/shoulder width	3.0/2.0m
crossfall (straight/curve)	2.5/max. 7.0%
minimum vertical radius (crest/sag)	5200/5000m

Total length of Rogovići–Matulji section is app. 46.3 km. Future highway is designed in a way to maintain the existing B8 carriageway, where possible. One of the exceptions is where the existing road has design elements for 80 km/h on the Rogovići–Učka section (in the vicinity of Lovrinčići and Mrzličići viaducts). Underpasses Juršići and Dausi on the Cerovlje–Lupoglav section of A8 must be reconstructed because the existing free profile height is inadequate. Also, cemetery in Dolenja Vas conditioned the layout design on that part of the section, in addition to the close proximity of the Lupoglav–Raša railway corridor and Lupoglav–Vranja local road. The existing 'Vranja' junction will be allocated app. 1500m closer to Lupoglav, and the rest area in front of Istra portal of 'Učka' tunnel will be closed for traffic safety reasons. On Učka–Matulji section of A8 the existing carriageway will be maintained, except in the 'Veprinac' and 'Frančiči' junctions' area, where the layout is reconstructed to minimize the influence on residential buildings. The new carriageway is designed on the north (hillside) of the existing B8 carriageway on this section.

Cross section elements are assessed according to the design speed and road rank. On the parts of the section where the existing carriageway is maintained, emergency lane will be added and the existing road widened to fulfil the cross section width demands. (insufficient lane width on existing Cerovlje–Lupoglav section). There is a possibility of landslides near the Borut and Pazin creek, so retaining walls will have to be constructed. Also, big cuts, more than 30m in height will be necessary on the Učka–Matulji section, so the rock surface must be protected with nets to avoid slides.

#### 2.1.3 Junctions, overpasses, underpasses, pedestrian crossings



Construction of 9 junctions, 8 overpasses and 22 underpasses is expected. Junction position and number is compatible with spatial planning documents.

**Table 2** Junctions

junction	chainage	connection road category	junction configuration
Rogovići	0+000	D48/Ž5190	diamond
Ivoli	5+830	Ž5046/NC	diamond
Cerovlje	10+675	Ž5046	combined
Borut	14+670	L50082/NC	diamond
Lupoglav	23+380	D44	half clover
Vranja	28+395	D500	diamond
Veprinac	39+260	Ž5048	half clover
Andeli	41+770	Ž5048/NC	half clover
Frančiči	44+375	Liburnija beltway	trumpet

Highway A8 connects to junction 'Matulji2' at km 46+340 and trough it to highway A7. 'Frančiči' junction requires the construction of Liburnija beltway, which goes around Opatija and Lovran and is currently in design phase.

There are 9 existing pedestrian crossings (overpasses and underpasses) on Rogovići–Matulji section. The existing pedestrian overpasses Slavići, Puhari and Benčinići will be reconstructed into road overpasses to accomplish the connection between residential areas and the public road network. The rest of the pedestrian crossings will be reconstructed to accommodate the construction of the second carriageway. Also, two new ones will be constructed for tourist promotion of the hills over Opatija.

#### 2.1.4 Drainage

Rogovići–Matulji section of highway A8 goes through zones of sanitary protections at some parts of the section. The whole highway section will be constructed with a closed and controlled drainage system, using waterproof collector pipes to transport rainfall to purification stations from which it will be disposed into surrounding terrain. Drainage of the existing B8 carriageway at parts that currently don't have a closed drainage system (Čuleti–Matulji) will be reconstructed into a closed system at parts where the existing carriageway will be preserved.

#### 2.1.5 Rest areas

There will be two type B rest areas on Rogovići–Matulji section of highway A8: 'Lovrinčiči' at km 18+400 and 'Učka' at km 35+800. Each will have a gas station, coffee shop and parking. Rest area 'Lovrinčiči' is placed between Lovrinčiči and Dajčiči viaducts, on the north side of the highway. This layout is chosen because of the terrain configuration and to avoid reconstruction of the Cerovlje–Lupoglav local road. If some new discoveries are made at the later design stages, two–side layout can be used. Rest area 'Učka' is placed right after Kvarner portal of 'Učka' tunnel. It has a two–side layout, with the separation of commercial and maintenance use. The north side will be used for maintenance services, fast–response teams and reception of the vehicles carrying dangerous cargo. The south side overlooking the sea will have a gas station, coffee shop, view platform, and a helipad. Also, a cable car stop is predicted in the spatial plans.

### 2.1.6 Construction

Construction should be done without traffic stoppages on the existing B8 carriageway, if possible, because no substitute roads for heavy traffic exist on the Vranja–Matulji section, except state road D66 (Rijeka–Opatija–Plomin–Vozilići–Pazin). Second carriageway will be built first, and the reconstruction and widening of the existing carriageway will be executed after switching of traffic to the new one. Highway sections where both carriageways are constructed must be executed with temporary deviations at the connections to the existing carriageways and minimum traffic stoppages.

In the latest official changes of the Primorsko–goranska county spatial plans, a corridor from Veprinac to Jušiči/Jurdani needs to be explored as an alternative connection to A7. Suggested junction at the connection of these two corridors was elaborated in this preliminary solution.



Figure 2 'Veprinac 2' junction

### 2.2 'Učka' tunnel

'Učka' tunnel is situated inside the borders of Učka Nature park. The second tunnel tube will be constructed north of the existing one, and it will measure approximately 5.660m in length. The tunnel cross section will have two traffic lanes, with total carriageway width of 7,60m. It will be connected to the existing tube by lateral vehicle and pedestrian passages. Axis distance between the tubes ranges from 50 to 100m, with slope level of 0.5% in the second tube (0.4% in the existing). Standard cross section profile area is 56,23m<sup>2</sup>, with a longitudinal ventilation system. The predicted drilling method is the New Austrian Tunnel Method (NATM), which is suitable for the rock type.

Table 3 'Učka' tunnel technical data

2 <sup>nd</sup> tube	chainage	length (m)	cut profile (m <sup>2</sup> )
Istria portal	29+770-29+780	10,0	
tunnel tube	29+780-35+440	5.660,0	73,94
Kvarner portal	35+440-35+450	10,0	
lateral connections	number x length	total length (m)	cut profile (m <sup>2</sup> )
emergency niches	5 x 46,3	232,5	130,05
vehicle conn.	5 x 41,0	205,0	32,00
pedestrian conn.	18 x 41,0	738,0	13,10

Axis distance between the tubes at Istria portal is 100m to preserve the Bina–Istra headquarters and tunnel control centre. At km 31+100, under Pricejak peak, the axis distance gradually shortens to 50m, and stays constant until Kvarner portal and tunnel end.



Figure 3 Visualization – Istria portal of the 2nd tube

### 3 Environmental impact assessment procedure

Based on the preliminary solution, Environmental impact study was made, and the assessment process began. 1<sup>st</sup> conference of the Expert advisory commission was held in November of 2010, and the Commission members gave their comments and objections on the EIS and the preliminary solution. 2<sup>nd</sup> conference of the Expert advisory commission was held in February of 2011, where it was concluded that the revised EIS can be presented to the public. Copies of the EIS were presented in all city and borough centres, with public viewings in Opatija, Matulji and Pazin.

#### 3.1 Design changes based on Commission objections

After visiting the future highway route and reviewing the Study, Expert advisory commission gave its comments and objections on the design solutions and the need for additional hydro–geological and traffic studies. Objections included the setting of the second carriageway north of the existing one at Cerovlje–Lupoglav section. This design solution was done to avoid landslides on the section but for this design solution Pazin and Borut creek must be reconstructed, along with filling of the lakes made by clay exploitation near Cerovlje, which should become a recreation zone. Also, additional explanation for 'Lovrinčići' rest area and 'Vranja' junction had to be given. After additional terrain evaluation more design alternatives were made, and highway route was reconstructed to maintain the lakes around Cerovlje, but rest area and junction positions were proven to be optimal, given the terrain configuration and demands from Ministry of culture and local authorities. Design and Study changes were presented at the 2<sup>nd</sup> conference along with additional design explanation for the changes that weren't accepted, which the Commission agreed on and concluded that the revised Study can be presented to the public.

### 3.2 Public discussion and design changes based on public objections

Public discussion was carried out in March and April of 2011. All the public viewings of the Study had good attendance with high tensions, especially in Opatija and Matulji. Problem of highway construction in a high populated area from Učka to Matulji presented itself as the most important, so most of the questions and objections were about residential buildings devastation and owners buyout. In Istria, most of the questions and comments were about noise protection and 'Borut' junction position, since the highway doesn't pass through high populated areas in this county. After the public comments and objections were received from local authorities in written form, they were taken into account for the design changes. Unfortunately, many of the comments weren't taken into account because they referred to areas not covered by this project or to problems that only local and state authority can solve. One of the objections that changed the preliminary solution and showed that the public voice must be heard in large infrastructure projects was moving the position of 'Borut' junction from the one determined by county and borough spatial plans to an alternative one that will move heavy traffic from the towns of Borut and Cerovlje. Also, changes were made to the highway layout to save some of the buildings in the corridor, and additional noise barriers were designed where public suggestions were justified.

Unfortunately, during public discussion we learned that the general public lacks education about phases of the design procedure, or the permits that follow after every phase. This caused unwanted situations and unnecessary frustration. Because of this, we suggest that public should be educated about possibilities of their influence on this kind of projects, along with additional input of public opinion.

### References

- [1] Hidroelektra-projekt d.o.o.: Idejno rješenje autoceste A8, dionica Rogovići – Matulji, Zagreb, 2010.
- [2] Hidroelektra-projekt d.o.o.: Studija o utjecaju na okoliš autoceste A8, dionica Rogovići – Matulji, Zagreb, 2011.
- [3] Banjad, I.: Tunel 'Učka', Građevinar 5 (1978), pp 165-169, 1978.
- [4] Nadilo, B.: Dosadašnja izgradnja i dovršetak prve faze Istarskog ipsilona, Građevinar 58 (2006), pp 307-316, 2006.
- [5] [www.bina-istra.hr](http://www.bina-istra.hr)



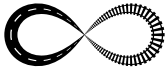

## DECISION MAKING PROCESS ON THE ANTWERP OOSTERWEEL LINK: LESSONS LEARNT

**Dirk Lauwers**

*Ghent University, Faculty of Architecture and Engineering,  
Department of Mobility and Spatial Planning, Belgium*

### Abstract

The Oosterweel link (completion of the Antwerp ring road, including a river Scheldt crossing) was planned to be the largest infrastructure project ever built in Belgium. It started as a noiseless process for more than fifteen years, the decision seemed to be taken in 2008: the reference design was approved and a DBFM consortium selected. Then the project became controversial. Action groups dominated the debate and could enforce a public referendum. The project was rejected by the Antwerp citizens. Can the rejection of the project be explained by opening the black box of the planning process? A research of the Antwerp University College Artesis reveals that the decision process of the Oosterweel link can be described within the three streams model (problems–policy alternatives–politics), developed by W. Kingdon. In each stream actors intervene with their own logic (e.g. experts use traffic models, politicians make political deals, and administrations refer to administrative rules...). The process streams were bundled by a policy maker (the governor of the province), creating for a certain period a 'window of opportunity'. But the research confirms that a project idea has its expiry date. From Kingdon's three project survival criteria the weak point of the Oosterweel project is its small problem definition (traffic congestion on the main road system). Major projects should refer to the mobility issue and not only to a traffic problem. Infrastructure planning should not be limited to the physical object to be built, but be embedded in the urban and regional environment (avoiding e.g. white backgrounds in project evaluations and design). Planning processes that only focus on control (of financial and technical issues) and omit interaction (with stakeholders and the general public) have a great risk to fail. This has huge consequences for project management.

*Keywords: large infrastructure projects, project management, complexity infrastructure projects, decision making theories, Antwerp ring road*

### 1 Introduction

A high level of mobility is one of key features of contemporary life in Europe. Mobility requires an infrastructure whose nature and especially whose capacity is being adapted to the changing needs of society. One of the basic tasks of government is to ensure adequate and timely availability of such infrastructure. In practice it appears that new infrastructure projects often have difficulties to be implemented. Planning processes for infrastructure projects often have an incident course, resulting in long delays or even cancelling of the project.

The Oosterweel link project, which comprises the completion of the Antwerp ring road (including the river Scheldt crossing) and makes part of the TEN-T network, is an illustrative case in this context. It was planned to be the largest infrastructure project and one of the most challenging road infrastructure projects ever built in Belgium. Planning and design of the project started as

a noiseless process, smoothly continuing for more than 15 years. In the period 2005–2008 all key decisions seemed to be taken:

- EIA and spatial implementation plan (legal basis for the building permit) were approved;
  - a dedicated project management organisation was established by the Flemish government (BAM, abbreviation for Beheersmaatschappij Antwerpen Mobiel, meaning Management Authority Antwerp Mobile);
  - a reference design and the budget were approved by BAM;
  - after a public tendering procedure a DBFM consortium was selected by the Flemish government.
- But then the project became controversial in as well the academic, the political as the professional world. Action groups dominated the debate for more than a year and could, according to Belgian law, enforce a public referendum, held 18th October 2009. The project was rejected by the Antwerp citizens.

A year of studies on new alternatives, public discussion and a step by step decision process started. A 'final' decision was taken by the Flemish Government to build a tunnel instead of a bridge on September 22nd 2010. Two years later this decision is also becoming controversial. And a subject of political struggle on urban, regional and even the national level.

In this paper we will not focus on the content or on the evaluation of the project alternatives but on the decision: how can a noiseless process turn into a political 'thriller'? To search for an answer to this question we rely, in this paper, on a research by Sandra Van Veldhoven (2009) at Artesis Antwerp University College (1). The subject of the research is the policy making process and agenda setting regarding the completion of the Antwerp Ring Road in the period 1990–2005. The time frame of the research covers the 'quiet' phase: from the first agenda setting of the project till definition to preliminary statutory definition of the project area by the Flemish Government (Spatial Implementation Plan). In this paper also some reflections on the period after 2005 are made.

## 2 Project description

The 'Oosterweel link project 2005' was based on a planning process resulting in an approved dedicated route by the Flemish Government on 16/09/2005 and extends over a length of approx. 10 km and makes a new northern ring road link, completing the southern existing part. It consisted of (see fig.1):

- the rebuilding of an interchange with the ring road on the left bank of the river Scheldt
- a (toll) tunnel under this river
- a new interchange with the port area and the city on the right bank
- a double deck viaduct in length of 2.3, over Royers lock and Straatsburg dock, also on the right bank (north of new urban development area 'Eilandje')
- an interchange and the rebuilding of the R1 (northern ring road)

The road infrastructure was also accompanied with nature compensation projects.

In its decision of 2 March 2007 the Flemish Government put a capital of 1.850 billion Euros on the estimated cost price of the infrastructure (excl.VAT and excl. the cost for financing). Also, it was decided to finance this investment by a Public Private Partnership. Investment costs are to be paid back over time by toll collection (toll rates 2012 had to be: €2.44 for passenger cars, €15.85 for lorries between 3.5 and 12 tons and between €15.85 and €19.00 for lorries over 12 tons).

The project was seen as a cornerstone for the accessibility of the city and port of Antwerp and the viaduct called 'Lange Wapper' was designed as a new landmark for the city.



**Figure 1** Project images: spatial location of project elements (left) and computer image of the double deck viaduct (2.3 km length) over Straatsburg dock, called 'Lange Wapper' (after an urban mythological figure)

### 3 The Kingdon model

#### 3.1 Kingdon's theory

Can the rejection of the strategic and ambitious Oosterweel link project be explained by opening the black box of the planning process? The assessment of this process described in this paper is based on the model developed by John w. Kingdon (2). The conclusions for the Oosterweel link were published for the first time before the (radical) turn of the process that took place in September 2009 (3).

Kingdon's theory is based on empirical research: interviews with 247 US top decision makers in the public sector on the one hand and in the health and transport sectors on the other hand, during a research period of four years.

The basic question of his research was: how does an issue emerge to the forefront of political attention, or 'how does an idea's time come'? He states that public policy making consists of a set of processes:

- 1 Setting of the agenda
- 2 Specification of alternatives
- 3 Authoritative choice amongst alternatives
- 4 Decision implementation

Success in one process does not imply success in others. Kingdon's theory can be seen as a revised 'garbage can theory' (4). How to understand policy process? Kingdon puts forward four principles:

- 1 Tracing the origin of initiatives is not relevant: ideas can come from anywhere (not necessary if they are from within the official planning process). Tracing origins of ideas involves infinite regress: in fact nobody leads anybody else, instead a combination of factors makes an item prominent or not.
- 2 Comprehensive rational decision making models do not describe real decision processes well: as actors often do not follow a clear set of goals and as they often do not assess the alternatives systematically (contrary to what is assumed in rational planning theories). Instead a somewhat accidental confluence of factors occurs.
- 3 Rejection of incrementalism: in many processes people proceed step by step but agenda changes appear discontinuous and non-incremental.
- 4 The garbage can model (Cohen, March and Olsen) is applicable to understand a certain type of organizations, called 'organized anarchies'. In these types of organisations (of which e.g. universities are a good example) different actors define their own preferences, preferences that often are inconsistent. The outcome of decision processes depends on the choice moment. On such moments a coupling of problems and solutions and the interactions of participants determine the outcome.



### 3.2 The Kingdon model as a process assessment tool

- Based on his theory Kingdon distinguishes three major and independent process streams:
- 1 the problem stream: represents information and events that may unchain a series of events related to placing or eliminating an issue from the agenda;
  - 2 the policy stream: refers to the knowledge or advice derived from researchers, consultants and technicians that offer alternatives or solutions that may or may not be considered or used by decision makers;
  - 3 the political stream: the will of the political system and actors to place an issue on the agenda and make an authoritative choice between alternatives.

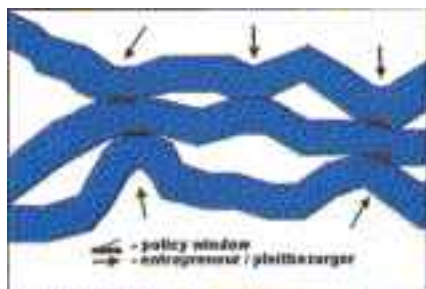

Figure 2 The three stream model, showing policy windows or 'windows of opportunity'.

Each of the process streams has its own logic and driving forces, e.g. researchers and professionals will use scientific methods, work within paradigms accepted by their peers, etc., whilst politicians will try to enlarge their power by making political agreements, maximise their support by potential voters etc.

But based on his research Kingdon states that these separate streams come together at critical times. If at the same time a problem is recognized, a solution is developed and available in the policy making community and thirdly a political situation (often a political change, e.g. the outcome of elections) makes it the right time for a political decision. These policy windows i.e. opportunities for action on given initiatives, present themselves and stay open for only short periods. Often it takes a policy maker – a kind of entrepreneur – to open the window, to understand and also to have the authority to open the window and to keep it open, i.e. to have the three streams tied together, despite the fact that they follow their own logic.

Apart from the three streams model Kingdon presents another interesting process assessment tool. Based on his research he puts forward three criteria for the survival of policy alternatives: a) Technical feasibility, b) Value acceptability, c) Anticipation of future constraints

## 4 Assessment of Oosterweel link planning process

### 4.1 Key findings of the research

Based on desk research and interviews with some twenty key figures (spread over three s defined by Kingdon) a (formal) decision making process of the Antwerp Oosterweel link in the period 1995–2005 was reconstructed and mapped.

The key findings were the following:

- 1 It is possible to describe the planning process of the Oosterweel link within the three streams model (problems–policy alternatives–politics). In each stream actors intervene with their own logic (e.g. experts use traffic models, politicians make political deals, administrations refer to administrative rules...)

- 2 The three streams were bundled by a policy maker : the former Governor of the Antwerp Province. But he retired in April 2008, at that moment nobody took over his role as a policy maker in the sense Kingdon describes it, although a Belgian top manager is leading the BAM since 2008.
- 3 The project idea of the Oosterweel link was not the result of a rational planning process (vision–strategies–actions): the idea of the 'closing' of the inner ring was not incorporated in the historical neither the at that time current spatial or infrastructural planning documents. Instead, these documents included a second outer ring project, without completing the inner ring. In fact the idea came from an action group that resisted the building of the outer ring on the left bank.
- 4 The problem definition was very narrow at the starting point: solving the traffic congestion on the ring road and connected access highways. Policy alternatives at the regional scale were limited to traffic simulations of inner and outer ring solutions (independent of the environment they cross), starting from trend scenarios (without incorporating modal shift). In other words: there was no connection to the broader mobility approach neither spatial and environmental context.
- 5 During the rest of the planning process a constant discussion ('battle') emerged to broaden the problem definition. At some points this happened, at other points the project was enclosed in a technocratic shielded organisation.
- 6 In the phase of the agenda setting the main policy alternatives were conceived on the scale of the urban region. As there was/is no political/administrative organisational structure dealing with the policy fields of the urban region an 'unsettled politics' environment, fertile for the 'garbage can' style policy processes existed.
- 7 Though later in the project a multimodal set of projects was embedded (including tramway expansions, inland waterway upgrading etc.), the so–called Masterplan for Antwerp, chances to incorporate the project in a mobility planning process at the scale of the urban region were missed (the ongoing regional mobility planning process was even stopped in 1996 with the opening of the policy window for the building of the Oosterweel link).
- 8 Changes in the political positions and the administrative personnel can explain some crucial decisions during the planning process. The starting position of the city council was very weak because of internal problems (emergence of a strong right wing party to be tackled by established political parties, financial abuse scandal by some main counsellors and their resignation). Partly this can explain why the policy alternatives proposed by the city administration were not really taken seriously.

## 4.2 Research epilogue

As already mentioned before, after the referendum the policy window for the original project was closed again. Politics took the formal lead of the process (a steering group was installed lead by the Flemish Government with the City Council of Antwerp and BAM). Action groups aligned with some 'captains of industry' and launched a new alternative (new tangential routes instead of the inner ring route), which was evaluated positively by different researchers. However the Flemish Government decided to stick to the inner ring route completion, but replacing the bridge project by a tunnel construction. On the other hand tangential connections (consisting of an existing upgraded road and a missing link) have been added to the Masterplan (for mobility in the city region).

## 5 Lessons learnt

Checking Kingdon's criteria for survival of policy alternatives yields the following.

- 1 Technical feasibility: the Oosterweel link project was conceived as a high standard technical masterpiece. It was rather its strong point than its Achilles' heel. However,

the original rejection of the tunnel alternative became controversial as a know-how for tunnel building developed.

- 2 Value acceptability: during the process of agenda setting a closed network (that was enlarged step by step) of specialists was engaged in the project planning process. The original disciplines of civil and traffic engineering were enlarged with financial experts and urban designers. Critics grew in disciplines of urban planning and medicine (public health). After the referendum the critical approach became more dominant.
- 3 Anticipation of future constraints: the project is seen as strategic and not (officially) doubted for reason of financial constraints. Though the original set budget had to be augmented several times (the originally approved budget by the Flemish Government of 1,82 billion euro has been adjusted by BAM to 2,5 billion euro and even this budget is criticised by the Financial Court). Public and political acceptance turned out to be the weakest point: position of (local) politicians changed, public opinion took the side of the activists (David versus Goliath syndrome). New style activism (highly professional and relying of the new social media) seems nowadays a stronger factor than assumed by Kingdon.

## 6 Conclusions

The analysis of the Oosterweel link decision process shows that the three streams defined by Kingdon – seen on a time axis – have both tendencies in order to converge as to disconnect. The project promoter, the provincial governor, who retired in April 2008, succeeded during his tenure to maintain the coupling of the three streams. The disappearance of this 'policy maker' can, according to the theory of Kingdon, be considered as one of the factors that have led to the eventful turn in the process. Although, other factors leading to the 'decoupling' of the process streams have been exposed in this paper as well. This shows that a project has a limited 'expiry date'. In policy circles currently there is a strong conviction, that planning and administrative procedures should be reduced. 'Faster and better' were the leitmotifs of the parliamentary and governmental committees that formulated conclusions in 2010 (not explicitly but probably not accidentally) installed shortly after the failure of the most important project planning process in the Flanders region in Belgium. The assessment of the decision process of the Oosterweel link however shows that not only simplifying administrative procedures is at stake, but also the quality of the processes of decision making, planning and design. The analysis clearly shows that the narrow approach of the problem definition and the narrow network of experts evolved after a while, because of constant questioning of the project by stakeholders and the general public. There is a need for a sufficiently broad definition of a project and open litigation, with an open communication in which various approaches of a project are discussed. The changed policy on spatial planning, environment and mobility in the period 1995–2005 were decisive for the process turn. Also, social trends such as a growing environmental and health awareness and the demand for citizen participation played a part. For the professionals – and especially for project leaders and managers of planning and design processes – it seems useful to keep in mind Kingdon's three streams. They provide a basis to cope with processes that are not always evolving according to a rational technical line.

## References

- [1] Van Veldhoven, S.: In de ban van de ring, onderzoek naar een complex ruimtelijk vraagstuk - de Oosterweelverbinding, Artesis Hogeschool Antwerpen, 2009.
- [2] Kingdon J.W.: *Agendas, Alternatives and Public Policies*, Harper Collins, London, 1995.
- [3] Van Veldhoven, S., Lauwers, D. & Goethals, M.: Het leerproces van Oosterweel, *RUIMTE*, 3, pp. 67-68, 2009.
- [4] Cohen, M.D., March, J.G. & Olsen J. P.: A garbage can model of organizational choice, *Administrative Science Quarterly*, 17, pp. 1-25, 1972.

## 6 ROAD PAVEMENT



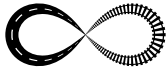

## PAVEMENT WIDENING ON ROAD CURVES

Željko Korlaet<sup>1</sup>, Tomislav Dobrica<sup>2</sup>, Ivica Stančerić<sup>1</sup>

<sup>1</sup> Faculty of Civil Engineering, University of Zagreb, Kačićeva 26, Zagreb, Croatia

<sup>2</sup> Croatian Roads, Vončinina 3, Zagreb, Croatia

### Abstract

Pavement widening on horizontal curves is necessary in order to ensure enough lateral clearance between two vehicles which are passing each other on the road curve in order to ensure undisturbed traffic flow. Guidelines and regulations of different countries offer different solutions for determining amount of traffic–lane widening on road curves. This paper shows the analysis of Croatian, Austrian, German and Swiss guidelines. Based on this analysis the optimum proposition for determining the required amount of traffic–lane widening on road curves has been offered.

*Keywords: pavement widening, curve radius, dimensions of design vehicle, vehicle movement geometry*

### 1 Introduction

Vehicles occupy more traffic–lane space when they are going through the horizontal curve compared to driving on straight road sections, since the back wheels describe smaller radius than the front wheels (Figure 1). That is the reason why it is necessary to widen traffic lanes (pavement) on curves, which depends on two basic parameters: curve radius and design vehicles dimensions. The third parameter on which the widening amount depends refers to the value of turning angle between the entry and exit curve tangent.

This paper provide analysis (comparison) of determining amount of traffic lane widening on curves, for the same characteristics of the curve and the design vehicle, according to the current guidelines of Croatia [1], Austria [2], Germany [3] and Switzerland [4]. The analysis has been limited to the horizontal curves radii  $R \geq 45$  m, since the radius  $R = 45$  m is the smallest allowed radius on open roads (for the lowest design speed of  $VP = 40$  km/h). Determining the amount of widening for the curves with radii ranging within  $R = 45\text{--}12,5$  m (hairpin bends, turning bays, intersections at grade,..) requires additional detailed analysis, due to the influence of vehicle movement geometry on small radii curves.

### 2 The ratio of 'D' and 'R<sub>v</sub>' parameters

It is common that in guidelines different types of the design vehicles relevant for determining the traffic lane widening are defined, ranging from the smallest (passenger car) to the biggest (truck trailer) vehicles. Unfortunately, dimensions of design vehicles in guidelines [1, 2, 3, 4] are not the same, which makes their comparison much more difficult. Thus, the analysis carried out in this study is limited to the biggest design vehicle, truck trailer, for two reasons: first, such vehicles require the biggest widening values which makes the differences more prominent, and second, the dimensions of such vehicles are standardized enough by guidelines since they are tied to the biggest allowed length of 18,75 m adopted on European level.

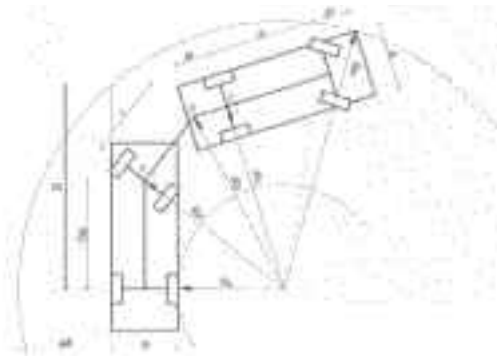
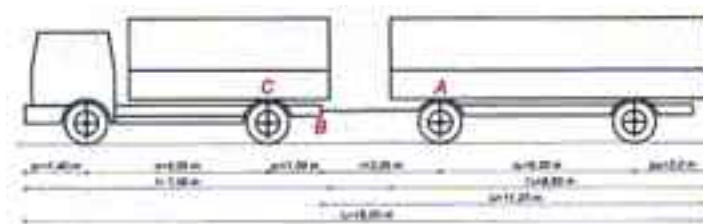

**Figure 1** Illustration of the vehicle movement geometry on the road curve

The common feature of all mentioned guidelines lies in the fact that in the procedure of determining the widening for truck trailer (assembly made of three parts: truck, drawbar and trailer) 'alternative' vehicle is used, the dimensions of which are characterized by the reduced length 'D' (Figure 1). The reasons why 'D' values mutually differ in some guidelines are probably related to the differences in the design vehicle dimensions (axle distance, front overhang, total length,...). One of the aims of this analysis is to test whether the differences in 'D' length influence the widening and to what extent. However, such uniformly determined 'D' length used for 'all' of curve radii is questionable due to the fact that the length 'D' also depends on the radius of the circular arc  $R_v$  according to the following formula [5]:

$$D^2 = R_v^2 - \left\{ \sqrt{\left[ \sqrt{R_v^2 - (o + p_1)^2} - \frac{b}{2} \right]^2 + p_1^2} - r^2 - o_p^2 + \frac{b}{2} \right\}^2 \quad (1)$$

According to the formula (1), for the truck trailer  $L=18,00$  m (Figure 2) and different radii  $R_v$  in Table 1 'D' values are shown. The truck trailer length of  $L = 18,00$  m was chosen for the reason that truck trailers of the maximum allowed length  $L = 18,75$  m appear very rarely in traffic, so that it is not logical to widen the roads for such exceptionally long vehicles. However, the results shown in the table 1 illustrate that even for the exceptionally small radii of curvature ( $R_v = 12,5 - 45$  m) length 'D' does not achieve the values (Section 3) contained in some guidelines ( $D = 9,77$  m – Austria;  $D = 10,00$  m – Germany;  $D = 10,00$  m – Switzerland)!



**Figure 2** The dimensions of the design vehicle  $L = 18,00$  m

**Table 1** 'D' values for ' $R_v$ ' radii and for the truck trailer  $L = 18,00$  m

$R_v$ [m]	D [m]
12,5	9,77
15	9,85
20	10,00
25	10,10
30	10,18
35	10,25
40	10,30
45	10,35
50	10,40
60	10,50
70	10,60
80	10,70
90	10,80
100	10,90
120	11,10
150	11,40
200	11,80
250	12,10
300	12,30
350	12,50
400	12,65
450	12,80
500	12,90
600	13,10
700	13,25
800	13,40
900	13,50
1000	13,60

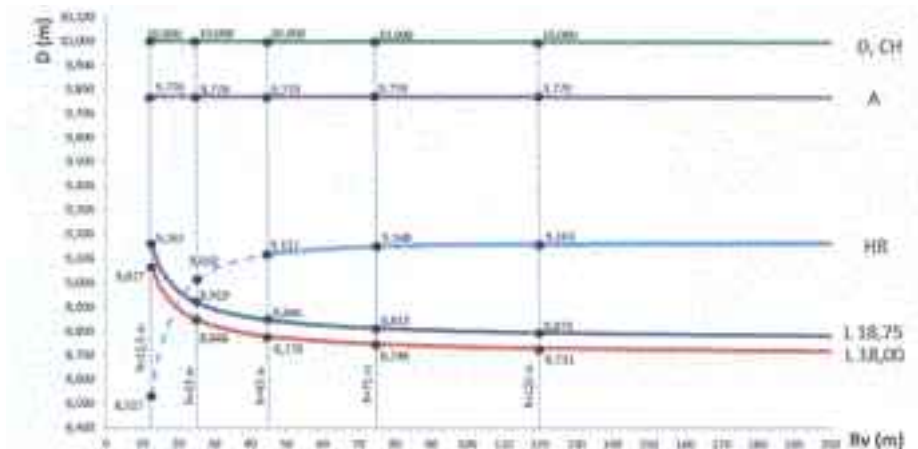

Figure 3 Illustration of 'D' values

The diagram in Figure 3 shows 'D' values for the truck trailer of the  $L = 18,00$  m and  $L = 18,75$  m. It is evident from the diagram that the influence of different values of the radius  $R_v$  on the 'D' length for the radii  $R_v \geq 45$  m is practically negligible, since the differences range within the limits of 6–7 cm, which is less than 1%. The differences in 'D' values for both truck trailers are also negligible ( $L = 18,00$  and  $L = 18,75$ ) and they range within the same limits (6–7 cm). Therefore, it can be concluded that 'D' lengths in foreign guidelines [2, 3, 4] are defined according to safety criteria, however the question arises whether such (excessive?) values result in irrationally big values of traffic lane widening?! This problem has been analysed in Section 3 of this paper. Differences in 'D' length become important only for the range of values of the radius  $R_v = 12,5 - 45$  m. This area is delicate due to the specificities that result from the laws of (big) vehicle movement geometry in small radii curves.

### 3 The method of calculating $\Delta s$ widening and the comparison of results

#### 3.1 Calculation of $\Delta s$ value [m]

##### 3.1.1 Croatian guidelines

The values of  $\Delta s$  in circular arc for one traffic lane, for the radii  $R \geq 45$  m and for the vehicle category – truck trailer, is determined according to the formula

$$\Delta a = 42/R \quad (2)$$

where 'R' represents the radius of road axis.

##### 3.1.2 Austrian guidelines

The necessary widening for one traffic lane is calculated by means of the formula:

$$i_{Fst} = (R - \sqrt{R^2 - D^2} + b_{Fz} - b_{Fst}) \cdot p' + S \quad (3)$$

where: ' $i_{Fst}$ ' represents traffic lane widening with the safety distance; 'R' – circular arc radius on the road axis; 'D' – reduced vehicle length; ' $b_{Fz}$ ' – maximum vehicle width (2,25 m); ' $b_{Fst}$ ' – the width of the traffic lane in the direction; ' $p'$ ' – reduction factor depending on the turning angle ' $\gamma$ '; 'S' – safety distance ( $S \geq 0,25$  m on the traffic lane).

$D_{max} = 9,77$  m (for truck trailer)



### 3.1.3 German guidelines

Pavement widening value 'i' is calculated according to the formula:

$$i = n \cdot (R_a - \sqrt{R_a^2 - D^2}) \quad (4)$$

where: 'D' represents reduced vehicle length; 'R<sub>a</sub>' – radius of the exterior pavement edge; 'n' – number of traffic lanes.

D = 10,00 m (for truck trailer)

### 3.1.4 Swiss guidelines

The necessary traffic lane widening 'e' is calculated according to the formula:

$$e = R_a - \sqrt{R_a^2 - D^2} \quad (5)$$

where: 'D' represents reduced length of the vehicle; 'R<sub>a</sub>' is the radius of the exterior pavement edge.

D = 10,00 m (for truck trailer)

## 3.2 The comparison of calculation methods

If different designations for the widening (i<sub>Fst</sub>, i, e) and some specificities in Austrian guidelines (b<sub>Fz</sub>, b<sub>Fst</sub>, p', s) are disregarded the formulas (3), (4) and (5) are structured in the same way and the widening is calculated according to the formula:

$$\Delta a = R - \sqrt{R^2 - D^2} \quad (6)$$

The same refers to Austrian guidelines which in their approach have initially 'built in' protective widths (the difference b<sub>Fz</sub> – b<sub>Fst</sub> and the value S), which in German and Swiss procedures were 'built in' subsequently. The same refers to the reduction factor p', which depends on the turning angle 'γ' and for big turning angles gets the value p' = 1 so it does not influence the widening value Δš. If we exempt these influences from formula (3), it takes the form of formula (6) which allows for the realistic comparison of values (A1 in Figure 4.) with the values of other guidelines and other calculations of the value Δš shown in Figure 4. The formula in Croatian guidelines (2) has been modified for the same reason (the possibility of comparison), due to the fact that it is the only one which is not initially based on the reduced vehicle length 'D'. By equalizing formulas (2) and (6)

$$42/R = R - \sqrt{R^2 - D^2}$$

and rearranging this equation we obtain the formula for the calculation of the reduced vehicle length 'D' depending on the radius 'R' in accordance with the method of setting the widening according to Croatian guidelines:

$$D = \sqrt{84 - \frac{42^2}{R^2}} \quad (7)$$

Based on formula (7) values 'D' for different values of the radius 'R' have been calculated and plotted in the graph in Figure 3. The chart makes evident that the influence of different values of the radius on 'D' length for the radii R ≥ 45 m is practically negligible since the differences range within the limits up to 5 cm. For the values of the radius R < 45 m (up to R = 12,5 m) the differences in 'D' length (dashed part of the curve) become big, but that fact is irrelevant for this study, especially because the guidelines explicitly emphasize that determining widening values Δš according to the formula (2) refers only to the radii R ≥ 45 m. The values of the length 'D' range around 9,15 m and are significantly lower than the values in Austrian (D = 9,77 m), German and Swiss (D = 10,00 m) guidelines.

### 3.3 The results of the calculation of maximum widening values

For all methods of widening calculation values  $\Delta s$  (m) have been shown in Figure 4 for curve radii  $R = 25, 45, 75$  and  $120$  m. The selected values refer to the minimum allowed radii of horizontal curves for the corresponding values of design speed ( $V_p = 30, 40, 50$  and  $60$  km/h) according to Croatian guidelines.



Figure 4 Widening values  $\Delta s$  (m)

## 4 Conclusion

### 4.1 Comparison of values $\Delta s$

The insight into the results shown in Figure 4 leads to the following features:

- as expected, widening values are the highest in German (D) and Swiss (CH) guidelines, owing to the biggest reduced length 'D' of 10,00 m;
- Austrian (A) regulations have the lowest values owing to the earlier described approach to calculation (the protective width). The shown values are determined for the traffic lane width of 3,00 m. The column A1 shows the values for Austrian guidelines ( $D = 9,77$  m) without the 'addition' according to formula (6), which are higher by app 0,5 m from the values in column A and are expectedly lower than D and CH values due to the shorter reduced length of  $D=9,77$  m.
- exact values of widening (L 18,00 i L 18,75) calculated for the real vehicles according to formulas (1) and (6) give the lowest values (with the exception of the value according to (A) – see the former explanation). The differences between L 18,00 and L 18,75 are negligibly small;
- results of Croatian guidelines (HR) are sort of 'surprise' with regard to the original formula (2) which does not contain the value 'D' as a relevant value for determining widening values, and the values are identical to those obtained through formulas (7) and (6). The obtained values (HR) are practically the same as the exact values for L 18,00 m and L 18,75.

On the basis of the above it follows that the calculation method according to Croatian guidelines is the optimum solution.

That is for two reasons:

- the formula ( $\Delta s = 42/R$ ) is the simplest one;
- the values of widening are the closest to the exact values (L 18,00 and L 18,75) for real vehicles.

This conclusion is not less relevant regardless the established (?) arguments that the values of the German (D) and Swiss (CH) guidelines are concerned with safety, which for the illustrated radius range  $R = 25\text{--}120\text{ m}$  are bigger for the amount of  $0,41\text{ m}$  ( $R = 25\text{ m}$ ) do  $0,07\text{ m}$  ( $R = 120\text{ m}$ ).

#### 4.2 Reduced values $\Delta s$ (the influence of the turning angle)

All mentioned guidelines contain the obligation of checking the influence of the turning angle on the necessity of reduction of  $\Delta s$  values determined according to the illustration in Section 3 of this paper. This obligation is based on the laws of vehicle movement geometry, which become more pronounced with the decrease in the values of the curve radius. Testing the need for the reduction of the amount of widening in this work is limited to the radius values  $R \geq 45\text{ m}$ .

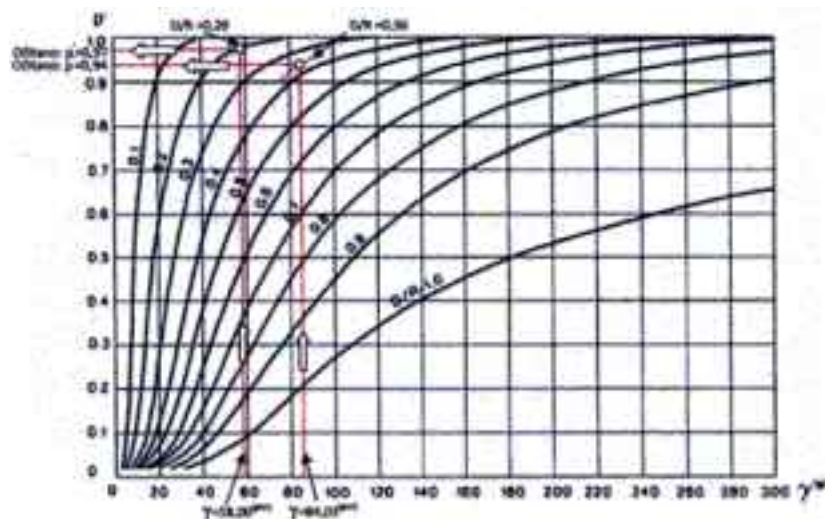

Figure 5 Determining the reduction factor

The limited range of this paper allows neither the more detailed explanation of the influence of the turning angle on the reduction of widening value  $\Delta s$  nor the precise illustration of the procedures involved in individual guidelines. Since the approach in foreign guidelines is basically very similar, in this analysis the used verification method is taken from Austrian [2] and Swiss [4] guidelines, according to which it is necessary to reduce the widening value if the specific turning angle (the central angle of the curve, i.e. the angle at which the tangents of the curve cross) is smaller than the minimum allowable intersection angle determined by the formula [4]:

$$\Phi_{\text{limit}} = 5,5 \arcsin (D/R)$$

The need for reduction is in Austrian and Swiss guidelines determined on the basis of the chart shown in Figure 5 by setting the reduction factor 'p' depending on the values of the turning angle 'gamma' and the relationship between parameters 'D/R'.

Croatian guidelines do not contain the reduction factor but there is a provision that for the radii  $R = 25\text{--}45\text{ m}$  the widening can still be determined as for the radii  $R \geq 45\text{ m}$ , if the turning angle of the curve is  $> 90^\circ$ , while for the radii  $R < 25\text{ m}$  the widening must be determined according to the provisions for hairpin bends. Whether and to what extent such provision corresponds to the real situation was tested on two specific examples of calculation of the turning angle 'gamma' for boundary cases permitted by guidelines [1] for the radii  $R = 45\text{ m}$  and  $R$

= 25 m. For the set value of the radius the smallest real turning angle ' $\gamma$ ' is determined by the minimum allowed length of the transition curve  $L_{\min}$  (graph 3.2 [1]) and by minimum allowed length of circular arc  $L_{K\min}$  (Table 3.2 [1]):

$$\begin{array}{llll} R = 45 \text{ m} & L_{\min} = 30 \text{ m} & L_{K\min} = 11 \text{ m} & \rightarrow \gamma' = 58,00(^{\circ}) \\ R = 25 \text{ m} & L_{\min} = 25 \text{ m} & L_{K\min} = 8 \text{ m} & \rightarrow \gamma' = 84,03(g) \end{array}$$

To use the graph in Figure 5 i.e. to determine the reduction factor 'p' it is necessary to set the relationship D/R, where the reduced lengths 'D' were used, which were for Croatian guidelines determined by the curve 'HR' in the graph in Figure 3.:

$$\begin{array}{llll} R = 45 \text{ m} & D = 9,117 \text{ m} & D/R = 0,20 & \rightarrow p' = 0,97 \\ R = 25 \text{ m} & D = 9,010 \text{ m} & D/R = 0,36 & \rightarrow p' = 0,94 \end{array}$$

On the basis of the above it follows that, if the designer adheres to the provisions of the guidelines [1] which refer to the application of values  $L_{\min} \leq L_{K\min}$ , for the radius  $R = 45$  m there is no need for reduction (the application of higher values  $L > L_{\min} \wedge L_K > L_{K\min}$  results in the increase of the turning angle), since the reduction factor is  $p' \approx 1$ .

Practically the same is true for the radii  $R = 45 - 25$  m, by which the 'limitation' contained in the regulations that the widening can be determined according to the formula (2) only if the turning angle is at least  $90^{\circ}$  (100g) becomes redundant.

## References

- [1] Book of regulations on the basic conditions which public roads outside settlements and their elements must fulfill from the standpoint of traffic, Narodne novine br.110/01, Zagreb, 2001.
- [2] Richtlinien und Vorschriften für den Straßenbau, rvs 3.23. Trassierung, Linienführung, 8.4. Fahrflächenverbreiterung im Bogen, Wien, 1997.
- [3] Richtlinien für die Anlage von Straßen, Teil: Linienführung, RAS-L 7.5. Fahrbahnverbreiterung in der Kurve, Bonn, 1995.
- [4] Schweizer Norm SN 640 105b, Verbreiterung der Fahrbahn in Kurven, Zürich, 2003.
- [5] Korlaet Ž., Vehicle movement geometry as the criterion for forming road traffic surfaces, Master's thesis, The Faculty of Civil Engineering of the University of Zagreb, Zagreb, 1981.





## VERTICAL DYNAMIC LOAD IMPACT ON THE PAVEMENT OF AN URBAN FRONT ENGINE BUS

Pablo Yugo Yoshiura Kubo, Cassio Eduardo Lima de Paiva  
*Universade Estadual de Campinas (UNICAMP), Brazil*

### Abstract

The objective of this paper is to quantify the dynamic vertical load imposed to the pavement on a Brazilian urban front engine bus application. The analysed bus had a 4×2 configuration and, as it is allowed in accordance with Brazilian law, had 6 tons on the front axle and 10 tons on the rear axle, as static loads. In order to quantify this condition, the rear axle was instrumented with strain gauges to simulate as a load cell. Measurements were done on a real urban application (Curitiba city, Brazil). Results showed significant differences between the static load, data used for pavement specification, and the dynamic vertical load, which could have a direct impact on the pavement lifetime.

*Keywords: commercial vehicle, pavement specification, vertical load*

### 1 Introduction

South American cities public transportation, unlike European cities, is done mainly by urban buses. In Brazil, 80% of the urban buses have a front engine setup. This configuration can be described as one of the simplest configurations among all commercial vehicles – Figure 1. In accordance with the Brazilian's legal demand, a 4×2 commercial vehicle configuration is allowed to transfer 6 tons on the front axle and 10 tons on the rear axle for the pavement, as static loads. Nevertheless, due to lack of fiscalization, it is common to find overloaded vehicles during city rush periods.

On the other hand, the main flexible pavement dimensioning methods, used in Brazil [2], consider different static load on each axle of a commercial vehicle (truck or bus). It means that, for dimensioning purpose, it is considered that the load of a truck, or bus, does not vary along the road.

Considering a simplification of the suspension of a commercial vehicle – quarter model car (Figure 2), it is clear that the spring  $k_1$  and the shock absorber  $c_1$  have a dynamic behavior; its consequence is the variation of acceleration of mass  $M_1$  that represents the entire vehicle. Therefore, the acceleration of mass  $M_1$  generates a dynamic load that is transferred to the road surface.



Figure 1 Typical front engine bus configuration [1]

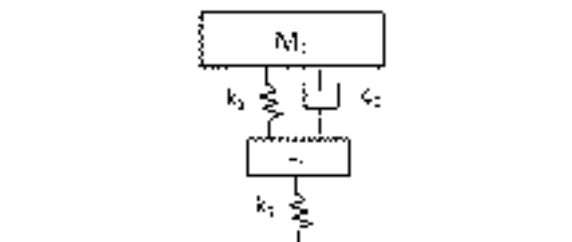

Figure 2 Quarter model car [3]

## 2 Methodology

In order to verify the real vertical load applied on the pavement, a rear axle of a 4x2 commercial vehicle, with the maximum load distribution allowed in Brazil for this type of vehicle (6 tons on the front axle and 10 tons on the rear axle) was instrumented. Both sides of the rear axle beam were instrumented with one rosette, as shown on Figures 3 and 4.

The signal output was given in micro strains ( $\mu\text{s}$ ), therefore it was necessary to calibrate the instrumentation setup, in order to have a correlation between the instrumentation output ( $\mu\text{s}$ ) and the load transferred to the pavement (tons). Calibration of the rosette is presented on Figure 5.

A typical urban route in Curitiba city (Brazil) was defined for the measurements – Figure 6. The route has been divided in 6 different tracks:

- Tracks 1 and 2: reasonable pavement quality.
- Tracks 3 and 4: poor pavement quality.
- Tracks 5 and 6: good pavement quality.



Figure 3 General view of the instrumented rear axle beam



Figure 4 Detail of the instrumentation of the left hand side of the rear axle beam – same instrumentation was made on the right hand side of the component



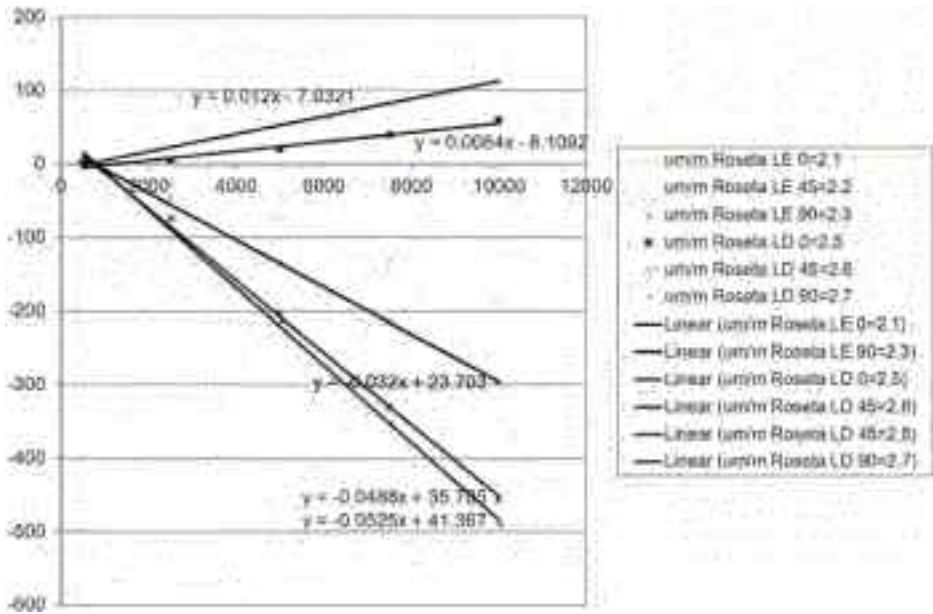

Figure 5 Equation for rosette calibration:  $\mu\text{s}$  to kg



Figure 6 Measured route – Curitiba city, Brazil – Source: Google Maps

### 3 Results analysis

The histograms for different parts (tracks) of the route were calculated – Tables 1 to 3. It is important to highlight that just the negative accelerations were taken into account, due to the fact that the positive accelerations do not affect the pavement lifetime. Likewise, the percentage sum of each histogram will not be equal to 100%.

**Table 1** A histogram regarding tracks with reasonable pavement quality

	Track 1					Track 2				
	10-11 tons	11-20 tons	20-30 tons	30-40 tons	>40 tons	10-11 tons	11-20 tons	20-30 tons	30-40 tons	>40 tons
Rear axle	21.13%	21.32%	0.13%	0.01%	+0.01%	44.36%	11.15%	0.34%	0.03%	+0.01%

**Table 2** A histogram regarding tracks with poor pavement quality

	Track 1					Track 2				
	10-11 tons	11-20 tons	20-30 tons	30-40 tons	>40 tons	10-11 tons	11-20 tons	20-30 tons	30-40 tons	>40 tons
Rear axle	21.23%	25.37%	3.11%	0.56%	+0.1%	25.43%	22.23%	2.55%	0.22%	0.03%

**Table 3** A histogram regarding tracks with good pavement quality

	Track 1					Track 2				
	10-11 tons	11-20 tons	20-30 tons	30-40 tons	>40 tons	10-11 tons	11-20 tons	20-30 tons	30-40 tons	>40 tons
Rear axle	71.67%	8.98%	0.02%	+0.01%	+0.01%	45.78%	30.57%	0.15%	0.13%	+0.01%

It is possible to verify that on tracks with good pavement quality the axle keeps loads close to its static value (10-11 tons), but even on reasonable pavement quality, due to the increment of vehicle speed and presence of depressions and holes, it is possible to find loads that vary from 11 to 20 tons.

This situation is even worse if we considered the poor pavement quality tracks, where loads from 20 to 30 tons can be found.

### 4 Conclusions and recommendations

After the results analysis, it can be concluded that the parameter used for the pavement dimensioning in Brazil (static load) is lower than the real vertical load applied on the road surface.

As mentioned before, due to the lack of fiscalization it is common to have commercial vehicles overloaded which can then generate bigger vertical dynamic loads to the pavement. In this way, it seems to be quite interesting to start a discussion about real loads applied on the road surface, in order to have a better pavement dimensioning and a more efficient maintenance program.

Also it is important to highlight that the authors of this paper are doing a research (Doctorate thesis) on this subject.

## References

- [1] VW, Volkswagen Truck and Bus, [www.caminhoeseonibus.com.br](http://www.caminhoeseonibus.com.br), 04.01.12.
- [2] DNIT, Manual de pavimentação (Pavement dimensioning guideline), Departamento Nacional de Infraestrutura de Transportes (Brazilian Department of Infrastructure and Transportation), Diretoria de Planejamento e Pesquisa (Directory of Planning and Research), Coordenação Geral de Estudos e Pesquisa (General Coordination of Studies and Research, Instituto de Pesquisas Rodoviárias (Institute of Road Research), 3rd ed, Rio de Janeiro, Brazil, 2006.
- [3] GILLESPIE, T. D.: Fundamentals of Vehicle Dynamics, Society of Automotive Engineers Inc., Warrendale, PA, 1992.

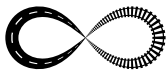

## PAVEMENT DESIGN OPTIMISATION CONSIDERING COSTS AND PREVENTIVE INTERVENTIONS

**Adelino Ferreira, João Santos**

*Department of Civil Engineering, University of Coimbra, Portugal*

### Abstract

In Portugal, as in many other countries, due to the economic crisis, the trend of budgetary pressures on highway agencies is increasing. At the same time, road users are increasingly demanding in terms of highway quality, comfort and safety. Several highway projects have been delayed because of budget constraints. To meet these challenges highway agencies are looking for more cost-effective methodologies for pavement management at project-level. This paper presents a new pavement design optimization model, called OPTIPAV, which considers pavement performance, construction costs, maintenance and rehabilitation costs, user costs, the residual value of the pavement at the end of the project analysis period, and preventive maintenance and rehabilitation interventions. It was developed and programmed to help pavement designers to choose the best pavement structure for a road or highway. The results obtained by the application of the new pavement design optimization model clearly indicate that it is a valuable addition to the road engineer's toolbox.

*Keywords: pavement design, pavement performance model; optimisation model*

### 1 Introduction

In Portugal, as in many other countries, due to the economic crisis, the trend of budgetary pressures on highway agencies is increasing. At the same time, road users are increasingly demanding in terms of highway quality, comfort and safety. Several highway projects have been delayed because of budget constraints. To meet these challenges highway agencies are looking for more cost-effective methodologies for pavement management at project-level. Highway pavements can be designed with many possible combinations of construction and maintenance and rehabilitation (M&R) strategies. It is desirable to find the optimal pavement structure, in terms of minimum cost while satisfying the engineering constraints, by modern mathematical methods and computer technology. Thus, there is a need to develop new optimization models to provide highway agencies with a better and more efficient decision-aid tool for pavement management at project-level. This paper presents a new pavement design optimization model considering costs and preventive interventions, called OPTIPAV, developed and programmed to help pavement designers to choose the best pavement structure for a road or highway.

## 2 Proposed pavement design optimization system

The proposed pavement design optimization system introduces some new capabilities in the previous version of the OPTIPAV system [1], including the possibility to consider preventive M&R operations. The OPTIPAV system uses the pavement performance model of the AASHTO flexible pavement design method [2] to predict the future quality of pavements. The results of the application of the OPTIPAV system consist of the optimal pavement structure, the predicted annual pavement quality, the construction costs, the M&R plan and costs, the user costs, and the pavement residual value at the end of the project analysis period (Figure 1).

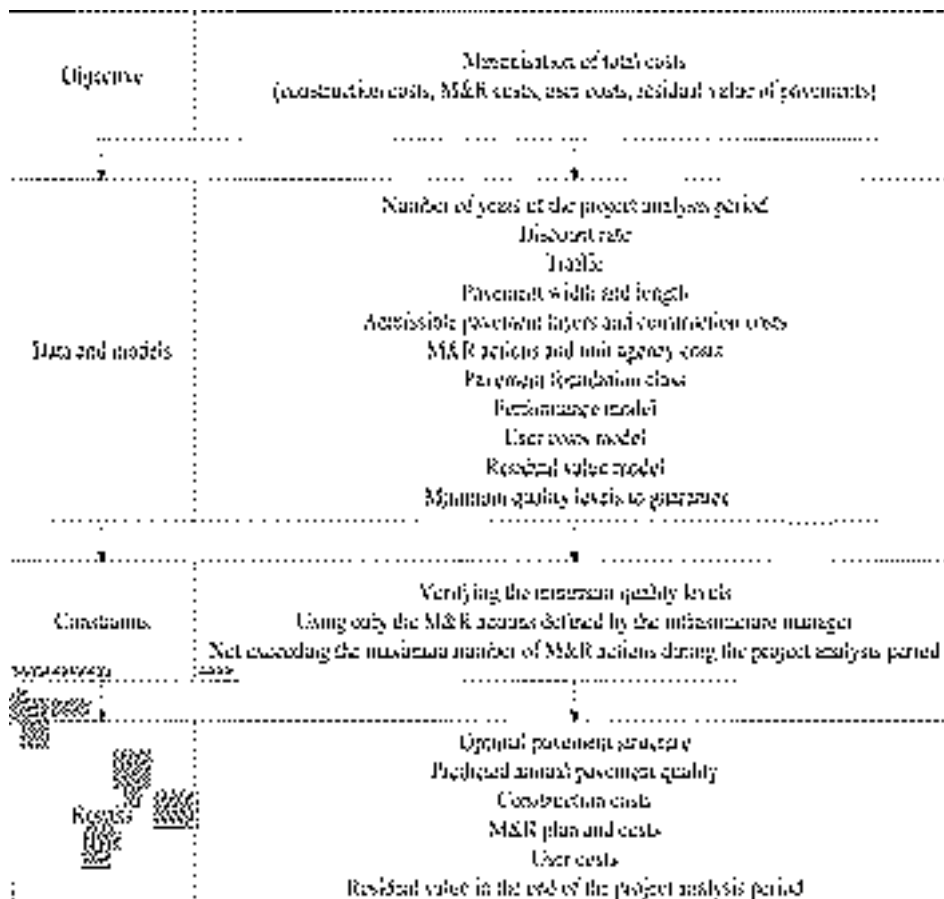

Figure 1 OPTIPAV system components

### 3 Case study

#### 3.1 Introduction

The Portuguese manual [3] recommends pavement structures in relation to traffic class (from T1 to T6) and pavement foundation class (from F1 to F4). The traffic class is defined by the number of 80 kN equivalent single axle load (ESAL) applications for a design life or design period calculated depending on the annual average daily heavy-traffic (AADTh), the annual average growth rate of heavy-traffic (gh) and the average heavy-traffic damage factor or, simply, truck factor ( $\alpha$ ). On the other hand, the pavement foundation class is defined by the California Bearing Ratio (CBR) value and the design stiffness modulus ( $E$ ). The Portuguese manual considers 16 different flexible pavement structures for different combinations of traffic and pavement foundation. These pavement structures were defined using the Shell pavement design method [4], with verification by using the University of Nottingham [5] and Asphalt Institute [6] pavement design methods. In order to define optimum pavement structures for national roads or highways, the OPTIPAV system was applied to 384 combinations of traffic (6 different values), foundation (4 different values of the foundation stiffness modulus), and pavement structure (16 different flexible pavement structures), using a costs optimization approach considering preventive M&R operations (Tables 1 and 2). In application of the OPTIPAV system, the following statistic design values were considered: a ZR value of -1.282 and a So value of 0.45 [2]. A discount rate equal to 3% was used in the analysis.

Table 1 Maintenance and rehabilitation actions

M&R action	Description	Cost
1	Ditching	€100/m <sup>2</sup>
2	Truck coat	€141/m <sup>2</sup>
3	Surface leveling (4 cm)	€120/m <sup>2</sup>
4	Surface leveling (2 cm)	€240/m <sup>2</sup>
5	Medium structural rehabilitation (266 kN)	€1480/m <sup>2</sup>
6	Base layer (10 cm)	€860/m <sup>2</sup>
7	Base layer (15 cm)	€1020/m <sup>2</sup>
8	Non structural wearing layer	€330/m <sup>2</sup>
9	Wearing layer (4 cm)	€900/m <sup>2</sup>

Table 2 Maintenance and rehabilitation operations

M&R operation	Description	Work volume (m <sup>2</sup> )	Cost
1	Rehabilitation	1	€10000
2	Non structural surface rehabilitation	2:3:2:4	€51600
4	High structural rehabilitation	2:4:2:5:2:6	€122800
4	Medium structural rehabilitation	2:4:2:5:2:2:6	€162900
1	Medium structural rehabilitation	2:2:2:5:2:4:6:6	€203000

#### 3.2 Results of the application of the OPTIPAV system

The results presented in this paper were obtained for the following data and conditions: two traffic classes (T1 and T5) characterized in Table 3; one type of pavement foundation (F3 with CBR equal to 20% and design stiffness modulus equal to 100 MPa); sixteen different pavement structures with the characteristics presented in Figure 2; a project analysis period of 40 years. Table 3 also shows the pavement structure recommended in the Portuguese manual for traffic class T5 and pavement foundation F3 (P4) and for traffic class T1 and pavement foundation F3 (P14). The characteristics of the pavement structures presented in Figure 2 (type

of material, thickness, stiffness modulus; Poisson's ratio, CBR, etc.) are the characteristics considered in the pavement design process using the Shell and two other pavement design methods from which was developed the Portuguese manual of pavement structures. Figure 3 shows the construction costs of each pavement structure. As expected, the construction costs increase with the pavement structural capacity defined by the structural number (SN) considered in the AASHTO pavement design method.

Figure 4 presents the M&R costs during the entire project analysis period for the sixteen pavement structures and for traffic classes T5 and T1. As expected, the M&R costs tend to decrease with the pavement structural capacity defined by the structural number (SN), and for both traffic classes T5 and T1 the P16 is the least-M&R-costs pavement structure. The explanation for the small increase of some M&R costs with the pavement structural capacity is due to the objective of the analysis, which was the minimization of total discounted costs (construction costs, M&R costs, user costs and the residual value of a pavement) over the project analysis period and not the minimization of only M&R costs.

Table 4 presents the M&R operations to be applied to the sixteen pavement structures, during the entire project analysis period, considering traffic class T5 and T1. Figures 5 and 6 represent the predicted PSI value over the years of the project analysis period, for each pavement structure and traffic classes T5 and T1, as a consequence of the execution of the M&R operations. These Figures show, as expected, that for the lowest traffic class (T5) and for all pavement structures, the degradation of the PSI value during the project analysis period is slower than for the highest traffic class (T1).

They also show that using weak pavement structures (with a small SN value) the PSI value decreases quickly in the first years of the project analysis period. Then with the application of M&R operations (the SN increases, making these pavement structures stronger) the PSI value decreases slowly in the remaining years of the project analysis period.

Considering traffic class T5, if pavement structure P4 recommended by the Portuguese manual is adopted then two M&R operations will need to be applied during the project analysis period. Both will be M&R operation 2 (non structural surface rehabilitation) and they must be applied in the 20th and 35th years of the project analysis period (Table 4).

Considering traffic class T1, if pavement structure P14 recommended by the Portuguese manual is adopted then five M&R operations will need to be applied during the project analysis period. M&R operation 2 (non structural surface rehabilitation) must be applied in the 7th, 29th and 36th years of the project analysis period and M&R operation 3 (light structural rehabilitation) must be applied in the 11th and 19th years of the project analysis period (Table 4).

**Table 3** Traffic classes and corresponding values

Traffic class	Traffic			Equivalent traffic (ET)	Pavement layer depths			Pavement structure
	AASHTO	PSI	n		Gravel	Base	Subgrade	
T5	300	3	3	0.88x10 <sup>6</sup>	17	100	2.75	P4
T1	3000	4	4.5	1.72x10 <sup>7</sup>	17	100	3.75	P14

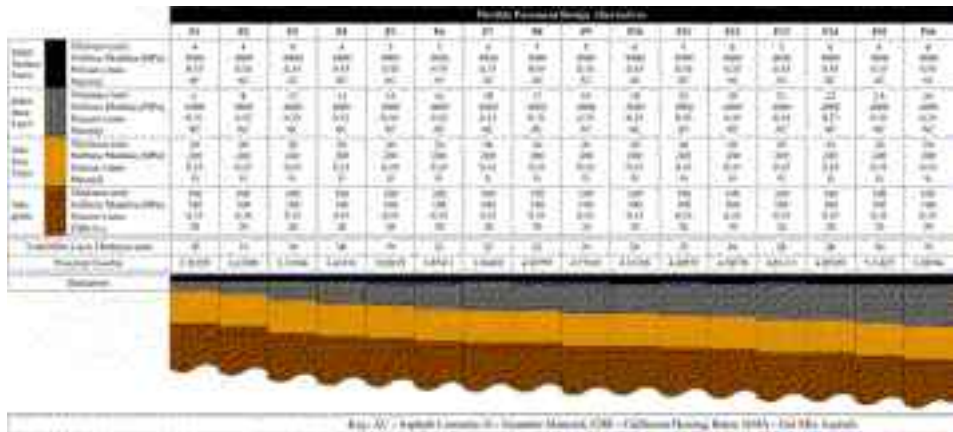

Figure 2 Characteristics of pavement structures

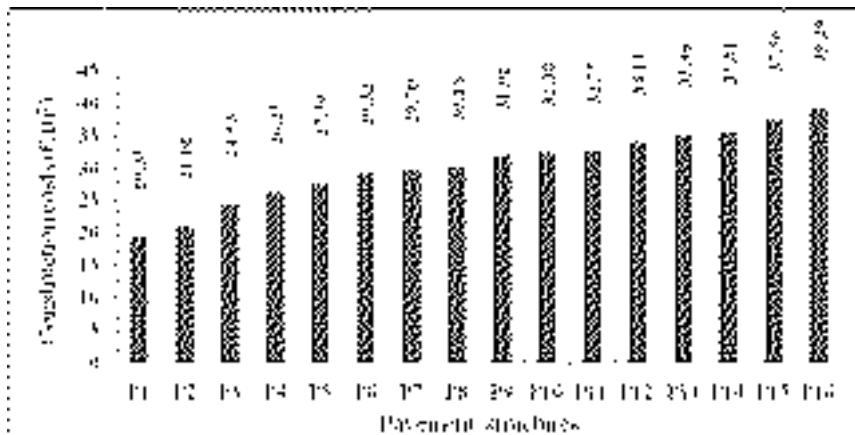

Figure 3 Construction costs of pavement structures

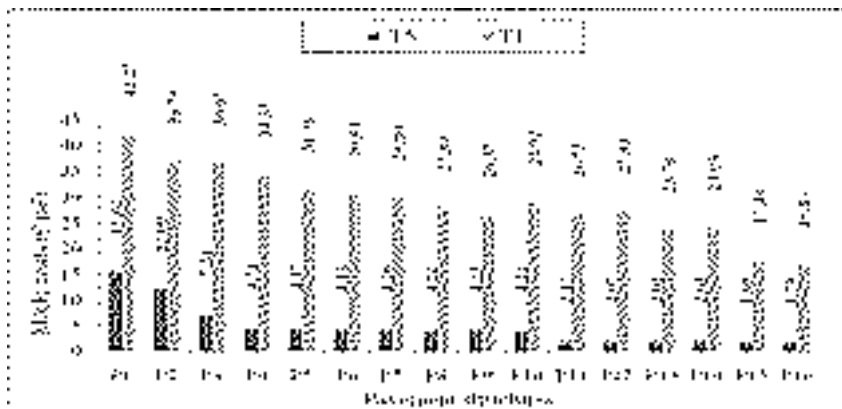

Figure 4 M&R costs throughout the project analysis period



**Table 4** M&R operations to be applied in pavements

Pavement Structure	Rehabilitation operations			
	Traffic class			
	T5		T1	
	Operation (year)	Final PSI	Operation (year)	Final PSI
P1	3(3); 2(23); 2(36)	4.25	5(1); 3(8); 3(16); 2(26); 2(34)	4.28
P2	3(7); 2(30)	3.92	5(1); 2(9); 2(14); 2(22); 2(27); 2(33); 2(37)	4.31
P3	2(16); 2(26); 2(38)	4.39	5(2); 3(8); 2(20); 2(29); 2(35)	4.29
P4	2(20); 2(35)	4.16	5(4); 3(13); 2(20); 2(27); 2(34)	4.26
P5	2(21); 2(38)	4.42	5(4); 3(14); 2(23); 2(33)	4.22
P6	2(24); 2(39)	4.50	5(5); 3(14); 2(27); 2(35)	4.33
P7	2(23); 2(39)	4.50	3(5); 3(9); 2(15); 2(24); 2(32); 2(37)	4.26
P8	2(25); 2(39)	4.50	5(5); 2(16); 2(24); 2(32); 2(37)	4.39
P9	2(24); 2(38)	4.45	5(5); 2(13); 2(24); 2(33)	4.19
P10	2(25); 2(39)	4.50	4(5); 3(13); 2(25); 2(34)	4.30
P11	2(30)	4.11	2(4); 5(11); 2(21); 2(29); 2(36)	4.36
P12	2(31)	4.17	2(5); 5(9); 2(22); 2(31); 2(37)	4.41
P13	2(32)	4.24	3(5); 2(9); 2(19); 2(26); 2(31); 2(37)	4.37
P14	2(32)	4.24	2(7); 3(11); 3(19); 2(29); 2(36)	4.37
P15	2(34)	4.33	2(9); 2(17); 3(22); 2(29); 2(36)	4.30
P16	2(36)	4.41	2(10); 2(18); 3(24); 2(30); 2(36)	4.33

KEY (M&R actions): 1 – Do nothing; 2 – Non structural maintenance; 3 – Minor rehabilitation; 4 – Medium rehabilitation; 5 – Major rehabilitation.

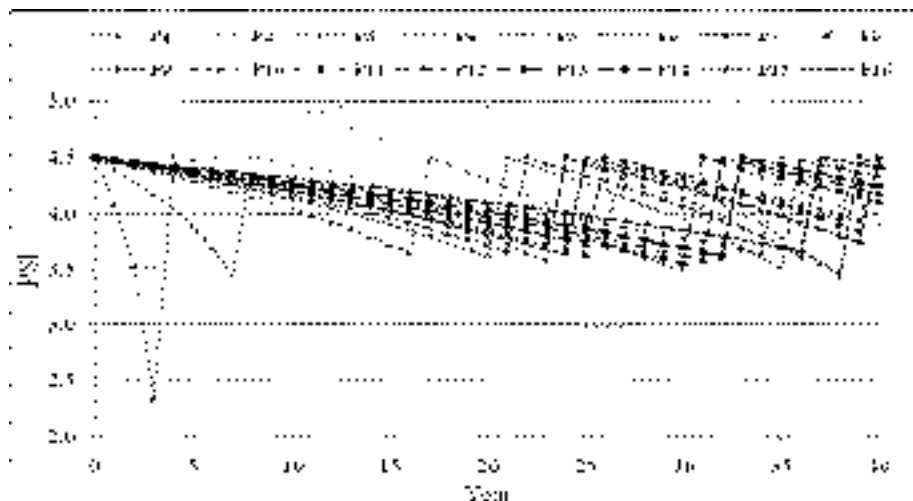

**Figure 5** Evolution of PSI for each pavement structure and traffic class T5

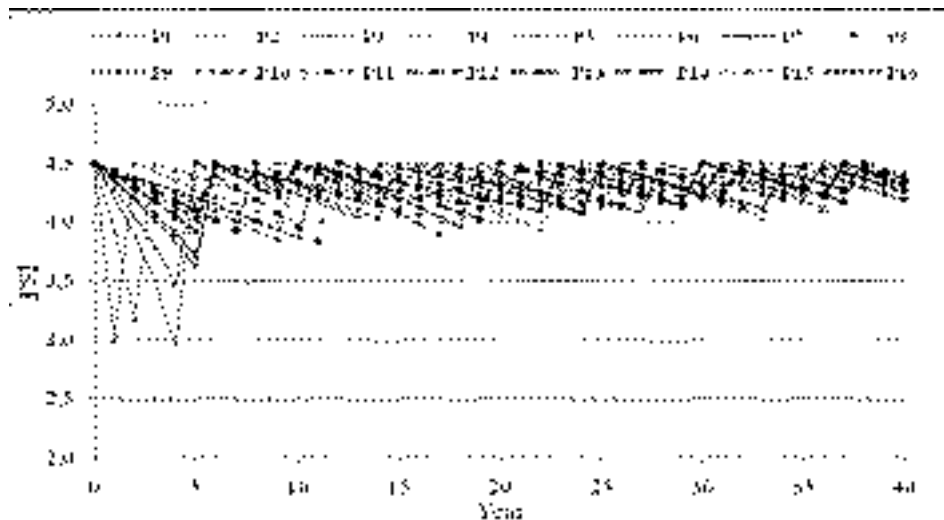

Figure 6 Evolution of PSI for each pavement structure and traffic class T1

Table 5 presents the pavement structures recommended by the Portuguese manual and the optimum pavement structures defined by using the OPTIPAV system. One can see that in eleven cases the optimum pavement structure defined by using the OPTIPAV system has more structural capacity, in five cases it has the same structural capacity, and in two cases it has less structural capacity. In most cases, pavement structures with more structural capacity allow savings in terms of life cycle costs.

Table 5 Optimum pavement structures

Traffic class	Trafico				ESAAI	Parâmetros recomendados			Estruturas recomendadas	
	Appl.1	Appl.2	g (cm)	g		ESAAI	Equilíbrio	J	γ	Manual
50	1.500	150	3	2	0.29x10 <sup>6</sup>	11	30	0.55	S&F	P14
75	1.000	500	3	2	0.08x10 <sup>6</sup>	11	30	0.55	S&F	P18
100	1.000	500	4	4	1.37x10 <sup>6</sup>	11	30	0.55	S&F	P15
125	8.000	800	4	4.5	1.59x10 <sup>6</sup>	11	30	0.55	S&F	P18
150	12.000	1.200	5	5	7.75x10 <sup>6</sup>	11	30	0.55	S&F	P15
175	20.000	2.000	5	5.5	15.28x10 <sup>6</sup>	11	30	0.55	S&F	P18
200	1.500	150	3	2	0.29x10 <sup>6</sup>	12	30	0.55	P4	P7
15	1.000	500	3	2	0.08x10 <sup>6</sup>	12	30	0.55	P7	P5
75	1.000	500	4	4	1.37x10 <sup>6</sup>	12	30	0.55	P10	P15
100	8.000	800	4	4.1	1.21x10 <sup>6</sup>	12	30	0.55	P10	P16
125	12.000	1.200	5	5	5.25x10 <sup>6</sup>	12	30	0.55	P10	P19
150	20.000	2.000	5	5.5	15.28x10 <sup>6</sup>	12	30	0.55	P10	P18
175	1.500	150	3	2	0.29x10 <sup>6</sup>	13	30	0.55	P2	P3
15	1.000	500	3	2	0.08x10 <sup>6</sup>	13	30	0.55	P4	P4
75	1.000	500	4	4	1.37x10 <sup>6</sup>	13	30	0.55	P6	P9
100	8.000	800	4	4.5	1.59x10 <sup>6</sup>	13	30	0.55	P6	P15
125	12.000	1.200	5	5	7.75x10 <sup>6</sup>	13	30	0.55	P12	P18
150	20.000	2.000	5	5.5	15.28x10 <sup>6</sup>	13	30	0.55	P12	P18
175	1.500	150	3	2	0.29x10 <sup>6</sup>	14	30	0.55	P1	P1
15	1.000	500	3	2	0.08x10 <sup>6</sup>	14	30	0.55	P3	P3
75	1.000	500	4	4	1.37x10 <sup>6</sup>	14	30	0.55	P5	P5
100	8.000	800	4	4.5	1.59x10 <sup>6</sup>	14	30	0.55	P6	P7
125	12.000	1.200	5	5	7.75x10 <sup>6</sup>	14	30	0.55	P10	P16
150	20.000	2.000	5	5.5	15.28x10 <sup>6</sup>	14	30	0.55	P12	P17

## 4 Conclusions

The pavement design optimization system proposed in this paper, called OPTIPAV, can solve the problem of making LCCA for typical design periods (20 years), but also for long periods (40 years or more), in order to compare different pavement solutions in terms of global costs for the final choice of the pavement structure for a national road or highway. Additionally, the OPTIPAV system has the capability of making LCCA with or without optimization, and using only corrective rehabilitation operations or using both preventive and corrective M&R operations. The OPTIPAV system provides a good solution to the pavement design problem considering not only design criteria but also construction costs, maintenance costs, user costs and the residual value of pavement structures. The application of the OPTIPAV system to the case study permitted us to conclude that the pavement structures recommended by the Portuguese Manual are not always the optimum solutions. In most cases, pavement structures with more structural capacity allow savings in terms of life cycle costs. Although the proposed pavement design optimization model was developed using data from Portugal, it can be applicable in different countries with appropriate calibration. In addition, the proposed pavement design optimization model can easily be adapted to consider rigid pavements, other pavement performance models, other costs, as well as different types of M&R operations.

## Acknowledgment

The authors are grateful to the Portuguese Foundation of Science and Technology for the financial support provided to this study through Grant PTDC/ECM/112775/2009 – Multi-Objective Decision–Aid Tool for Highway Asset Management, financed by the European Community Fund FEDER.

## References

- [1] Santos, J. & Ferreira, A.: Life-cycle cost analysis system for pavement management at project level. The International Journal of Pavement Engineering. First published on: 06 October 2011 (iFirst), DOI :10.1080/10298436.2011.618535.
- [2] AASHTO: Guide for design of pavement structures. American Association of State Highway and Transportation Officials, Washington, DC, USA, 4th ed., pp. 1-640, 1993.
- [3] JAE: Manual of pavement structures for the Portuguese road network, Junta Autónoma de Estradas, Lisboa, Portugal, pp. 1-54, 1995 (in Portuguese).
- [4] Shell: Shell pavement design manual - asphalt pavements and overlays for road traffic, Shell International Petroleum Company Ltd., London, UK, 1978.
- [5] Brunton, J., Brown, S. & Pell, P.: Developments to the Nottingham analytical design method for asphalt pavements, Proceedings of the 6th International Conference on Structural Design of Asphalt Pavements, Ann Arbor, Michigan, USA, 1, pp. 366-377, 1987.
- [6] AI: Thickness design: asphalt pavements for highways and streets, Asphalt Institute, Lexington, KY, USA, pp. 1-98, 2001.

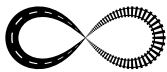

## DEPENDENCY BETWEEN ROAD SURFACE GEOMETRY AND SKID RESISTANCE

**Markus Weise, Wolfram Ressel**

*University of Stuttgart, Institute for Road and Transport Science,  
Chair for Road Design and Construction, Germany*

### Abstract

Safety and functionality are the basic requirements in road construction. To meet these requirements the qualitative and quantitative influence of the extrinsic and intrinsic factors of safety and functionality requires a detailed investigation. If the wearing course as the interface between road and tyre is considered exclusively, good skid resistance (drainage capability, friction) and acoustic behaviour constitute the most important surface characteristics. They are strongly influenced by the geometrical properties of the wearing course and may have contradictory needs. As an example, there is an overlapping domain in which the wavelength of the road texture influences both, the skid resistance and the acoustic characteristic of the wearing course. The long-term objective is to develop models for simulating all the single characteristics of the wearing course. For this purpose, every single characteristic has to be investigated and modelled independently. Then, the single approaches can prospectively be combined for artificial material design.

The main focus of the current research lies on investigating the skid resistance of roads. Therefore priority is on identification of the dependency between road surface geometry and the related dimensions of skid resistance, which is still not completely explored. First, geometrical parameters of measured textures will be determined to characterise isotropic asphalt surfaces. Secondly, virtual textures on various wavelength dimensions will be generated by utilisation of the multi-scale fractal structure. Then, the combination of geometry and the appearing friction build the tribological model. This model will be transferred into a contact mechanical simulation to reproduce rubber friction numerically. Results of the simulation will be the forces in related micro-contact points. From this the rubber friction coefficient and the real contact area between tyre and road can be derived. This will give the opportunity to specify the connection between various road surface geometries and the related dimensions of skid resistance.

*Keywords: skid resistance, friction, texture analysis, tribology, simulation*

### 1 Introduction

Skid resistance is the force which comes to effect when a tyre that is prevented from rotating slides along the pavement surface. The related interrelation of contact mechanic between tyre and road surface is not completely investigated.

Accidents due to pavement skid resistance deficiencies are a major concern of highway authorities. They have to ensure that drivers are able to use a road securely. For this reason monitoring and controlling skid resistance of pavements is an important component of road surface maintenance and is measured periodically. Skid resistance measurements can also be used to evaluate various types of materials and construction practices. Skid resistance can be me-

asured by various methods but all devices have in common that they are tactile techniques where a rubber tyre or slider has to be rubbed over a wetted road surface. The results of such measuring methods are friction forces which are characterised by wide ranges of dispersion and are confined to small parts of the road surface. The mentioned measuring methods provide friction values for either single spots or for a single continuous line in the wheel track of a lane. Large parts of the road surface with potentially low skid resistance remain undetected. Furthermore, the need to wet the surface makes measurements elaborate and expensive. These disadvantages make it desirable to develop a contactless method to determine skid resistance of a road surface. To quantify skid resistance by a contactless method, dependency between surface geometry (texture) and skid resistance has to be investigated fundamentally.

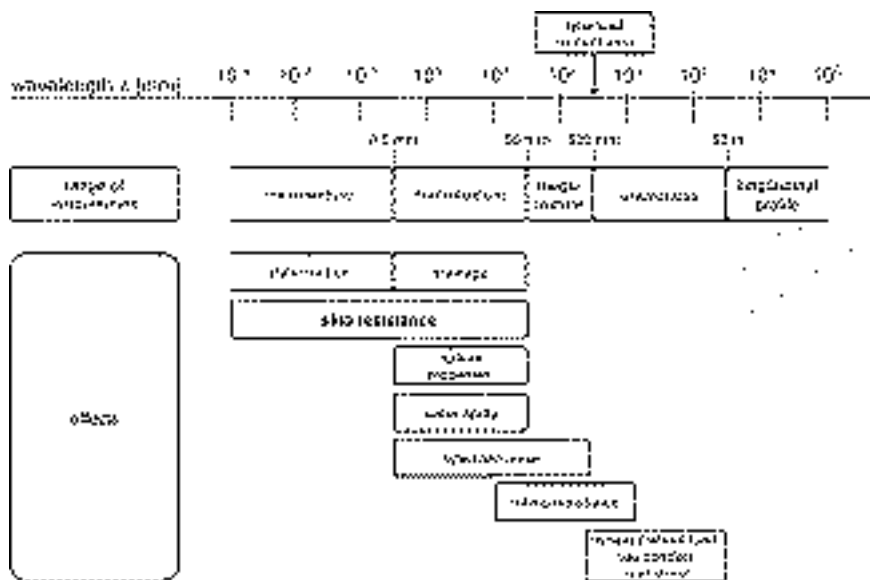

Figure 1 Wavelength spectrum of a road surface and effects on road safety [1]

Fig. 1 shows that different wavelength dimensions of a texture affect different surface characteristics. Skid resistance depends on pavement's microtexture and macrotexture. Macrotexture refers to the large-scale texture of the pavement (range of texture wavelength 0,5 mm – 50 mm) and is influenced by the aggregation of particle arrangement. It provides drainage volume and reduces the danger of hydroplaning. Microtexture refers to the fine scale texture of the pavement aggregate component (range of texture wavelength 1  $\mu$ m – 0,5 mm). It controls the contact between the tyre rubber and the pavement surface. In consequence, rubber friction between tyre and road surface is primarily influenced by microtexture. [1]

Basically, rubber friction consists of two major components (Fig. 2). The first component is adhesion. It is the result of temporary molecular bonding between the two surfaces and depends on the size of contact area between the elastomer and the rigid rough surface. The true contact area depends on the surface texture, material properties and the contact pressure. It is much smaller than tyre contact patch. The second component is hysteresis what is the main cause of energy loss associated with rolling resistance. It is attributed to the viscoelastic characteristics of rubber. As the tyre rotates under the weight of the vehicle, it experiences deformation and recovery, and the hysteresis energy loss is dissipated as heat. Warmed up tyres possess a larger area of contact with the road surface. So, hysteresis indirectly influences the adhesive component of rubber friction and is supposed to be the significant friction component at higher driving velocities. [2]

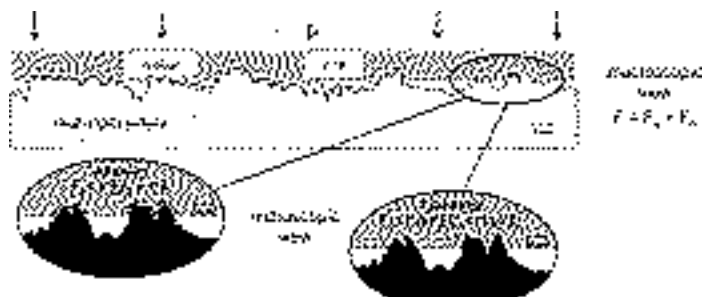

Figure 2 Friction interaction between tyre and road [2]

Main goal of this research is to identify the dependency between road surface geometry and related dimensions of skid resistance by simulating hysteresis component of friction between rubber and rough surfaces on microscale (Fig. 3). First, geometrical parameters of textures will be determined to characterise isotropic asphalt surfaces. Secondly, virtual textures on various wavelength dimensions will be generated by utilisation of the multi-scale fractal structure of technical surfaces.

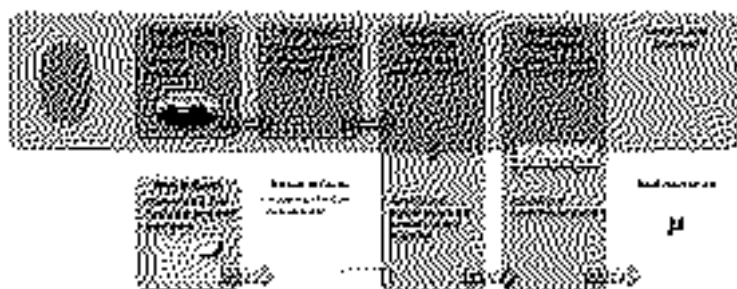

Figure 3 Overview: From asphalt texture to the skid resistance

The derived tribological model will be transferred into a contact mechanical simulation method to reproduce rubber friction virtually. Results of the simulation will be the forces in related micro-contact points, hence the rubber friction coefficient and the real contact area between tyre and road surface.

## 2 Texture geometry modelling

### 2.1 Data pre-processing

For the depiction of skid resistance, high-resolution microtexture data of asphalt surfaces are necessary, which had been derived from precise optical measurement systems. Therefore, different asphalt samples had been scanned with a structured light 3D scanner within a wide range of microscale. Results of the scans are measuring fields on asphalt samples sized 12 mm x 7,6 mm with 912.000 data points and a lateral resolution of 10 µm. As a first pre-processing step the measuring field were squared to the size 5,12 mm x 5,12 mm. Afterwards different methods were applied to interpolate missing data and eliminate noisy data and inconsistencies such like outliers. As mentioned above, the frictional component of skid resistance depends on pavement's microtexture. Therefore, as a second step the asphalt texture was separated for further geometry evaluation into its long-wave (waviness) and short-wave range (roughness) (Fig. 4).

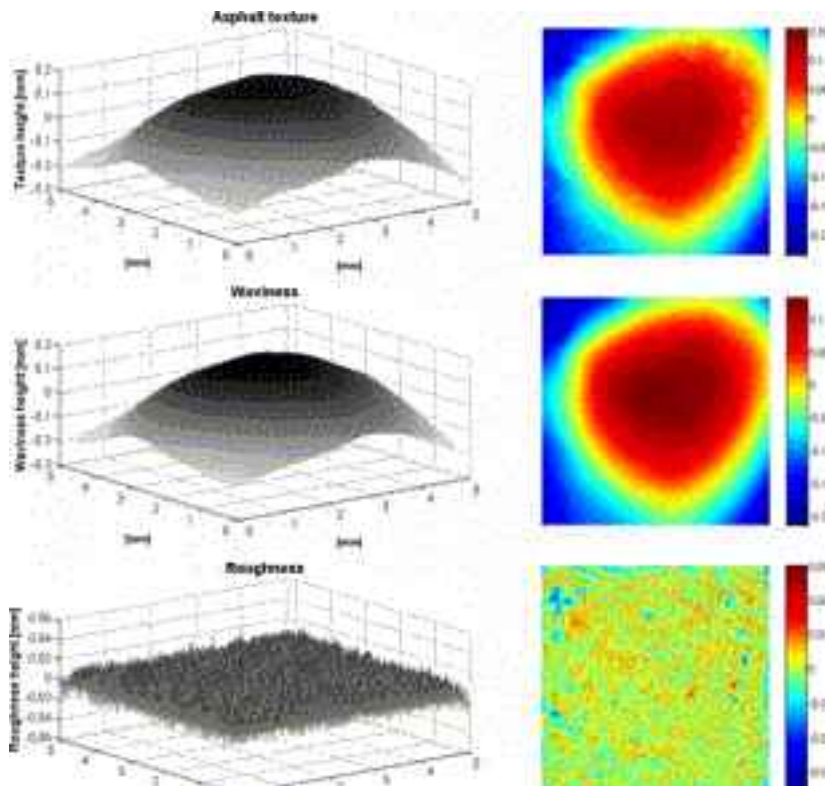

Figure 4 Separation of asphalt texture in waviness and roughness by 2D Gaussian filter

An approximation of a 2D Gaussian filter algorithm with high computational efficiency, established by [3], was implemented, which ensures both amplitude accuracy and zero phase characteristic. The filter for 3D surfaces is defined as shown in Eq. (1), whereas  $h(x,y)$  is the 2D Gaussian distribution, the constant  $\beta = \ln 2/\pi$  and  $\lambda_{xc}$ ,  $\lambda_{yc}$  are the cut-off wavelengths in the x and y directions. The 2D distribution is used to perform filtering using convolution methods.

$$h(x,y) = \frac{1}{\beta \lambda_{xc} \lambda_{yc}} e^{\left\{ -\frac{\pi}{\beta} \left[ \left( \frac{x}{\lambda_{xc}} \right)^2 + \left( \frac{y}{\lambda_{yc}} \right)^2 \right] \right\}} \quad (1)$$

## 2.2 Determination of texture's characteristics

For the characterisation of various asphalt surfaces including their isotropic textures, geometrical parameters are required, which will directly influence the subsequent simulation of friction. For this purpose, texture heights had been described by their statistical properties. Roughness parameters identify the small-scale variations in the height of a physical surface. These parameters can be used to characterise surface texture. For a long time these parameters were based upon 2D contact measurements, but in the last years the increasing amount of contactless 3D measurements methods led to a standardisation of the analysis of 3D texture [4]. The amplitude properties, e. g. root mean square, surface skewness or kurtosis, are described by different parameters, which give information about the statistical average properties, the shape of the height distribution histogram and about exceptional properties. Hybrid parameters reflect slope gradients and may be used for a further differentiation of the surfaces with similar amplitude properties. (Table 1)

**Table 1** Calculated parameters of a high and a low grip sample

	Parameter	high grip sample	low grip sample
amplitude parameters	Sa [μm]	6,243	4,033
	Sq [μm]	8,122	5,163
	Ssk [-]	0,847	0,017
	Sku [-]	4,483	3,680
	Sz [μm]	88,004	66,239
	Sp [μm]	54,367	30,046
	Sv [μm]	-33,693	-36.193
hybrid parameters	Sdq [μm/μm]	6,373	6,389
	Sdq6 [μm/μm]	5,857	5,230
	Sdr [%]	1401,37	1477,22

The functional parameters of a surface can be derived by calculation of the Abbott Firestone Curve (Fig. 5), which is also called material ratio or bearing area ratio curve. This curve is calculated by accumulation of the height distribution histogram and the subsequent inversion and gives information about material and void volumes constituting a texture. Thus makes it possible to characterise the surface involved in contact phenomena [5].

Another possibility to analyse textures is the transduction of surface's geometry into the frequency domain. Therefore, a height difference correlation function (HDC) has been applied, which connects lateral distances with mean height differences (Eq. 2, Fig. 5). Further we can derive descriptors from HDC, like the coordinates of the cut-off point and the fractal dimension  $D_p$ , which describe dimensions of surface roughness quantitatively. [6]

$$\Gamma_H(dx) = \langle (z(x+dx) - z(x))^2 \rangle \quad (2)$$

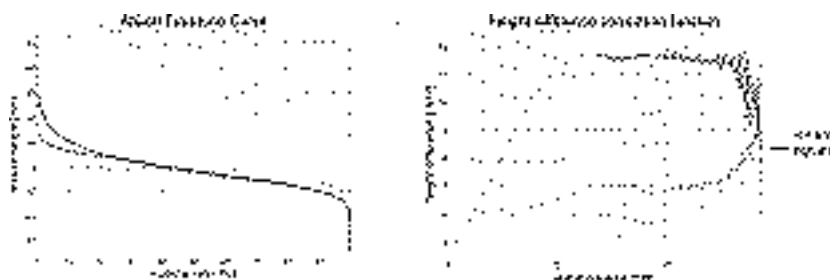

**Figure 5** Abbott Firestone Curve and two-dimensional height difference correlation function of a low and a high grip asphalt sample

### 2.3 Creation of equivalent scale dependent textures

Nevertheless, the lower resolution limit of the microtexture, which is indeed unknown, could not be imaged. The development of an optical measurement system which fulfils the requirements would be time-consuming and expensive. Therefore, in this project, virtual texture geometries are modelled as the basis for a tribological model. Tribological models are assumed to have a multi-scale fractal structure. Asphalt as an irregular geometric object has an infinite nesting of texture across all scale ranges (Fig. 6). These textures are called self-affine.



That means statistical properties of a surface are invariant under the scaling transformation  $\zeta$  (Eq. 3), where the exponent  $H$  can be related to the fractal dimension via  $D_f = 3 - H$  ( $0 < H < 1$ ) [7].

$$x \rightarrow \zeta x, y \rightarrow \zeta y, z \rightarrow \zeta^H z \quad (3)$$

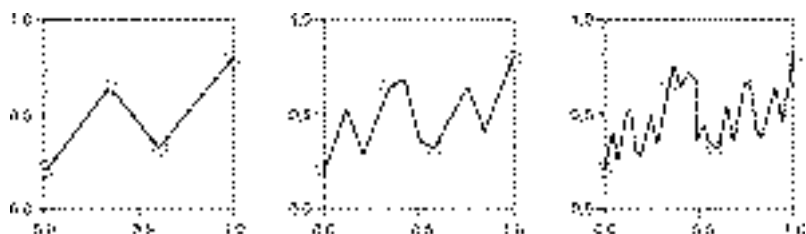

Figure 6 Irregular geometric object with infinite nesting of texture across all scale ranges

The scale invariance can be used to create virtual textures down to microscale's lower limit based on the existing geometrical parameters of asphalt surfaces from the scanned samples. Thereby textures can be formed, which qualitatively have the same texture on different scales and cover the lower wavelength range of the microtexture.

### 3 Outlook

#### 3.1 Tribological model

##### 3.1.1 Dimensionality reduction

The following simulation of the hysteresis rubber friction component is based on the generated virtual textures on different scale ranges. It has been realised long ago that surfaces are rough on a microscopic scale, and that this causes the real contact area to be extremely small compared to the nominal area [8]. The difficulty of tribological systems and their simulation is the understanding of the multi-contact conduction of rough surfaces on different scales. To handle these problems and to reduce large volume of texture data a hierarchical simulation method shall be applied [9]. Therefore, we reduce the three-dimensional contact problem into a simplified analogous system, which has the identical contact properties as the three-dimensional texture (Fig. 7).

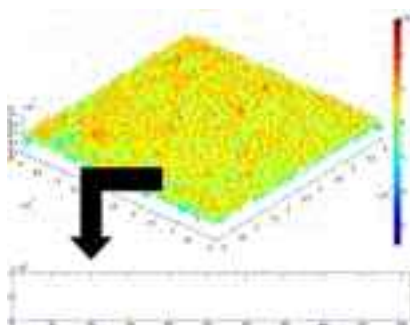

Figure 7 Reduction of the 2D surface of a texture into a simplified 1D profile

Popov [10] assumes that the topography of a two-dimensional surface (of a three-dimensional texture) can clearly be described by its power spectral density (PSD)  $C_{2D}(q)$ . Eq (4) allows the transfer of a two-dimensional system into a one-dimensional system with identical contact properties.

$$C_{2D}(\vec{q}) = \frac{1}{(2\pi)^2} \int \langle h(\vec{x})h(\vec{0}) \rangle e^{i\vec{q}\cdot\vec{x}} d^2x = \frac{1}{\pi\vec{q}} C_{1D}(\vec{q}) \quad (4)$$

In this case the height distribution and radii of curvature of a texture have the same order as the quadratic mean of the height distribution and radii of curvature of the entire profile. It is important to consider that the roughness of the elastomer plays only a minor role in the process of hysteresis. [10]

### 3.1.2 Simulation of rubber friction

The simulation is based on the derived equivalent 1D-model from section 3.1.1 in which the viscoelastic material is brought into contact with the rough surface in a defined distance. That is the way profiles will be discretised into defined steps  $x$ . Depending on time step and velocity, normal and tangential force can be calculated for each discretisation step. Ratio between the mean of tangential and normal force results in a rubber friction coefficient. Microcontacts are now characterised by a respective length and are identified as connected regions in the simulation. The contact area can be calculated from the sum of the respective lengths. The tribological model will be calibrated by means of the determined roughness parameters. [10]

### 3.2 Validation and Optimisation

In the first step of the validation the virtually created geometric textures will be compared with real-life texture data from the scanned samples. This validation is essential to demarcate the infinite possibilities of virtual texture characteristic and to ensure asphalt geometry resembles reality as much as possible. In the second step, the determined friction coefficient from simulation will be validated against measured friction coefficients of the samples from a linear friction tester. A linear friction tester makes it possible to do measurements of all orthogonal force components during friction process. Besides the friction coefficient, elastic modulus of the applied elastomer can be determined. Facultative measurements can be undertaken by changing conditions like temperature, sliding velocity or contact pressure. By evaluation of the results of the two validation steps both texture geometry and tribological model can be optimised.

## References

- [1] Forschungsgesellschaft für Straßen- und Verkehrswesen (FGSV) / Arbeitskreis Oberflächeneigenschaften von Asphalt, Merkblatt: Merkblatt für den Bau griffiger Asphaltdeckschichten, M BgA, 2004.
- [2] Moore, D. F.: *The Friction and Lubrication of Elastomers*, 1972.
- [3] Yuan, Y. B.; Piao, W. Y.; Xu, J. B.: A fast Gaussian filtering algorithm for three-dimensional surface roughness measurements. In: *Journal of Physics: Conference Series*, Jg. 48, S. 1401–1406, 2006.
- [4] DIN Deutsches Institut für Normung e.V., DIN EN ISO 25178-2: Oberflächen-beschaffenheit: Flächenhaft - Teil 2: Begriffe und Oberflächen-Kenngrößen, März 2008.
- [5] Blateyron, F.: *New 3D Parameters and Filtration Techniques for Surface Metrology Digital Surf*, France, 2006.
- [6] Vanormelingen, K.; Degroote, B.; Vantomme, A.: Quantitative characterization of the surface morphology using a height difference correlation function. In: *Journal of Vacuum Science & Technology B: Microelectronics and Nanometer Structures*, Jg. 24, H. 2, S. 725, 2006.
- [7] Persson, B. N. J.: Theory of rubber friction and contact mechanics. In: *The Journal of Chemical Physics*, Jg. 115, H. 8, S. 3840, 2001.
- [8] Greenwood, J. A.; Williamson, J. B. P.: Contact of Nominally Flat Surfaces. In: *Proceedings of the Royal Society A: Mathematical, Physical and Engineering Sciences*, Jg. 295, H. 1442, S. 300–319, 1966.
- [9] Geike, T.; Popov, V.: Mapping of three-dimensional contact problems into one dimension. In: *Physical Review E*, Jg. 76, H. 3, 2007.
- [10] Popov, V. L.: *Kontaktmechanik und Reibung, Von der Nanotribologie bis zur Erdbeben-dynamik*, Springer, Berlin, Heidelberg [u.a.], 2010.

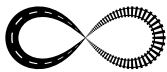

## RESISTANCE OF ASPHALT COURSES TO PERMANENT DEFORMATIONS IN THE FORM OF RUTS

Miroslav Šimun<sup>1</sup>, Andrea Strineka<sup>1</sup>, Tatjana Rukavina<sup>2</sup>

*1 Institut IGH d.d., Zagreb, Croatia*

*2 University of Zagreb, Faculty of Civil Engineering, Croatia*

### Abstract

The carriageway driving surface must have all the properties which guarantee safe and comfortable drive. One very significant property of the operating level of asphalt carriageways is the occurrence of permanent deformations in the form of ruts. The resistance of asphalt courses to rutting depends on several factors such as the properties of component materials of asphalt, composition of asphalt mix, properties and position of placed asphalt course in the pavement structure.

Measurements of the asphalt resistance to rutting were done using the small size Wheel Tracer measuring device, procedure B (in the air) in accordance with the standard HRN EN 12697-22. The work also included analyzing the dependence of the rut depth and the rutting speed on the composition of asphalt specimen, as well as the relative depth of rut in relation to the asphalt base in an optimal asphalt composition. The interdependence between the composition of asphalt specimen (three-component system) and composition of asphalt mix (two-component system) was also analyzed. The method of determining the resistance to rutting is described, as well as the testing requirements, testing stages and the complete procedure for determination of set parameters. The quality of asphalt mix components was previously laboratory tested, thus giving the input properties for designing the optimal asphalt composition. The confirmed optimal asphalt composition from the aspect of resistance to deformation was tested on varying thickness of courses and different combinations of asphalt courses. The influence of waterproofing and concrete carriageway slab as base on bridges was also tested for rutting. The degree of influence of bitumen as binder on the level of asphalt resistance to rutting was also tested on a series of asphalt courses, i.e. carriageway systems.

The determined dependence between parameters of asphalt courses tested by rutting and the asphalt components and asphalt mix components define the guidelines for pavement structure design. Asphalt pavement with a higher level of resistance to rutting shall fulfill the main road serviceability requirements over a longer period of exploitation.

*Keywords: driving surface, ruts, asphalt mix, pavement, waterproofing*

### 1 Introduction

Ruts are permanent deformities of asphalt pavement driving surfaces, which occur in traces of vehicles' wheels. The depressions in the form of ruts occur under traffic load, especially the canalised traffic load, on raising sections of roads and on intersections, on crossings (border crossings and toll station areas), on road sections where traffic flow is slow and on road structures. Rutting has an adverse impact to the road serviceability in terms of safety and comfort, as well as to the durability of the asphalt road structure, which is diminished due to the additional traffic-dynamic loads. Weather and exploitation conditions (high average air

temperature) cause plastic behaviour of asphalt, which may be reduced by application of an appropriate type of binder (bitumen) and of asphalt mixture whose composition shows higher resistance to permanent deformity.

Asphalt specimen is composed of stone skeleton and filler (depending on the size of particles, which can be under or over 0.09 mm in size), bitumen (absorbed, intergranulated, unbond and bound) and voids (open and closed). The basic grain size distribution of the stone skeleton of asphalt mixture remained the same, while the other two asphalt components were modified (share of filler and bitumen).

Investigation of the influence of asphalt composition to the occurrence and development of ruts in asphalt pavements served as the base for performed testing [1]. Optimised share of filler and bitumen in asphalt mixtures was determined first and then the combinations of asphalt courses and waterproofing on concrete slab were tested on resistance to rutting. Laboratory testing was carried out investigating the influence of physical-mechanical properties of asphalt specimens and share of bitumen in asphalt mix to the characteristics of ruts.

## 2 Interdependence of asphalt specimen composition and asphalt mix composition

The difference between asphalt specimen and asphalt mix is the content of voids in asphalt specimen; that is to say, the asphalt mix is a two-component system and asphalt specimen a three-component system. Asphalt mix is a form of asphalt specimen in which one of the components is lacking, namely the air, i.e. voids; in other words the content of voids equals zero [Figure 1].

Mathematical relations (1; 2; 3 and 4) show the relation between asphalt specimen composition and related asphalt mix composition according to [2,3]:

$$C_{B/AM} = C_{B/AU} * \frac{1}{(1 - \frac{C_{v/AU}}{100})} \quad (1)$$

$$C_{KM/AM} = C_{KM/AU} * \frac{1}{(1 - \frac{C_{v/AU}}{100})} \quad (2)$$

$$C_{P/AM} = C_{P/AU} * \frac{1}{(1 - \frac{C_{v/AU}}{100})} \quad (3)$$

$$C_{KS/AM} = C_{KS/AU} * \frac{1}{(1 - \frac{C_{v/AU}}{100})} \quad (4)$$

where:

- $C_{B/AM}$  – concentration of bitumen in asphalt mix
- $C_{B/AU}$  – concentration of bitumen in asphalt specimen
- $C_{SAU}$  – concentration of voids in asphalt specimen
- $C_{KM/AM}$  – concentration of stone material in asphalt mix
- $C_{KM/AU}$  – concentration of stone material in asphalt specimen

- $C_{P/AM}$  – concentration of filler in asphalt mix
- $C_{B/AU}$  – concentration of filler in asphalt specimen
- $C_{KS/AM}$  – concentration of stone skeleton in asphalt mix
- $C_{KS/AU}$  – concentration of stone skeleton in asphalt specimen

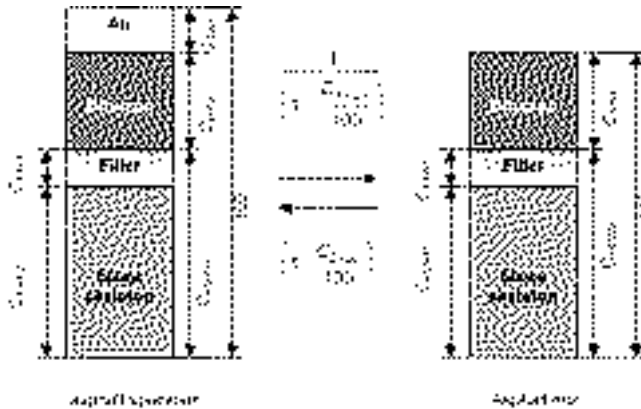

**Figure 1** Relation of concentrations of asphalt specimen and asphalt mix composition elements.

Volume share of stone material  $C_{KM/AU}$  in asphalt specimen presents the sum of stone skeleton share ( $C_{KS/AU}$ ) and filler share ( $C_{P/AU}$ ):

$$C_{KM/AU} = C_{KS/AU} + C_{P/AU} \quad (5)$$

Calculation of volume share of voids (air)  $C_{S/AU}$  in asphalt specimen according to HRN EN 12697-8 [4] requires data on spatial mass of asphalt specimen ( $\rho_{AU}$ ), and density of asphalt mix ( $\rho_{AM}$ ):

$$C_{S/AU} = \left(1 - \frac{\rho_{AU}}{\rho_{AM}}\right) * 100 \quad (6)$$

Volume share of bitumen in asphalt specimen  $C_{B/AU}$  is calculated as per the following relation:

$$C_{B/AU} = \frac{\%MAS_{B/AM}}{\rho_B} * \rho_{AU} \quad (7)$$

where:

- $\%mas_{B/AM}$  – mass percentage of bitumen in asphalt mix
- $\rho_B$  – density of bitumen

### 3 Determination of asphalt resistance to permanent deformity

Method of determining the asphalt resistance to permanent deformity is defined in the harmonised standard HRN EN 12697-22 [5]. According to the above-mentioned standard, the small size measuring device for testing of asphalt rutting when testing procedure B (in the air) is implemented, is called Wheel Tracker (Figure 2).

The device is composed of a 47 mm wide rubber wheel of 203 cm in diameter, which applies the load of 700 N to the tested specimen. The length of wheel path is 230 mm and the testing temperature is 60 °C; furthermore, prior to testing the specimen is tempered at the same temperature. Frequency of application of the load is 26.5 passes per minute and the total number of passes of the testing wheel amounts to 20 000 cycles, i.e. 10 000 cycles.



Figure 2 Wheel Tracker

### 3.1 Optimisation of asphalt mix composition

Asphalt-concrete AB 11 is the asphalt mix which has been used for testing of required characteristics; the mix was composed of stone material of eruptive origin, taken from Hruškovec quarry, Šumber stone dust and BIT 50/70 paving bitumen. Density of subfractions (0.09; 0.25; 0.71; 2; 4; 8 and 11.2 mm) was determined after sieving of stone material. Three asphalt mixes were prepared in order to select the optimal composition [Table 1]. The mixes had the same size distribution of stone skeleton, and the shares of filler in asphalt mix varied ( $\%mas_{P/AM}$ ), as well as the share of bitumen ( $\%mas_{B/AM}$ ). The relation (6) was used to determine the content of voids ( $C_{S/AU}$ ) on the prepared test Marshall specimens of different asphalt mixes. Calculation of share of voids was carried out based on previously tested density of asphalt mix ( $\rho_{AM}$ ) and special mass of the resulting asphalt specimen ( $\rho_{AU}$ ). In order to confirm the properties of the mix, the optimised composition of asphalt mix ( $AM_4$ ) was mixed with polymer-modified bitumen (PmB) and the share of voids was determined on the resulting asphalt specimen of the mix ( $AM_5$ ).

Table 1 Composition and properties of asphalt

Asphalt mix	$\%mas_{P/AM}$ [%(m/m)]	$\%mas_{B/AM}$ [%(m/m)]	$\rho_{AM}$ [g/cm <sup>3</sup> ]	$\rho_{AU}$ [g/cm <sup>3</sup> ]	$C_{S/AU}$ [%(v/v)]
AM1	10.7	3.6	2648	2429	8.3
AM2	9.4	7.2	2504	2455	2.0
AM3	9.0	5.1	2593	2466	5.0
AM4 -optimum	8.1	5.2	2581	2444	5.3
AM5 - PmB	8.5	5.3	2584	2468	4.5

The share of voids in asphalt specimen composed of selected stone skeleton, with share of filler ranging from 8 - 9 % and bitumen share amounting to 5.2%  $\pm$  0.2%, meets requirements (according to General Technical Conditions / 2001 [6] the required range is 3.5 – 6.5 %).

Confirmation of optimised composition of asphalt mixture was obtained through testing of resistance of completed asphalt course on occurrence of permanent deformity by application of the rutting method. Asphalt mixes (AM) were prepared in laboratory mixer and asphalt courses were compacted into 305x305x50 mm large moulds, using roller compactor. Table 2 presents shares of filler, bitumen and voids in asphalt mixes with respective rutting parameters RD (total rut depth) and PRD (proportional rut depth).

**Table 2** Asphalt mixes and relative rutting parameters

Asphalt mix	%mas <sub>P/AM</sub> [%(m/m)]	%mas <sub>B/AM</sub> [%(m/m)]	C <sub>S/AU</sub> [%(v/v)]	RD [ mm]	PRD [%]
AM1	10.7	3.6	8.3	2.15	4.3
AM2	9.4	7.2	2.0	8.6	17.2
AM3	9.0	5.1	5.0	2.45	4.9

Figure 3 presents increasing of rut depth expressed through tested parameters (total rut depth – RD and proportional rut depth – PRD) depending on the increase of bitumen share in asphalt mix. It was established that in case of optimal share of bitumen amounting to 5.1% (AM3), the depth of ruts meets requirements (RD=2.45 mm; PRD=4.9%), since according to the suggestions of the Technical regulation for asphalt pavement courses [7] the value of PRD should be ≤7%.

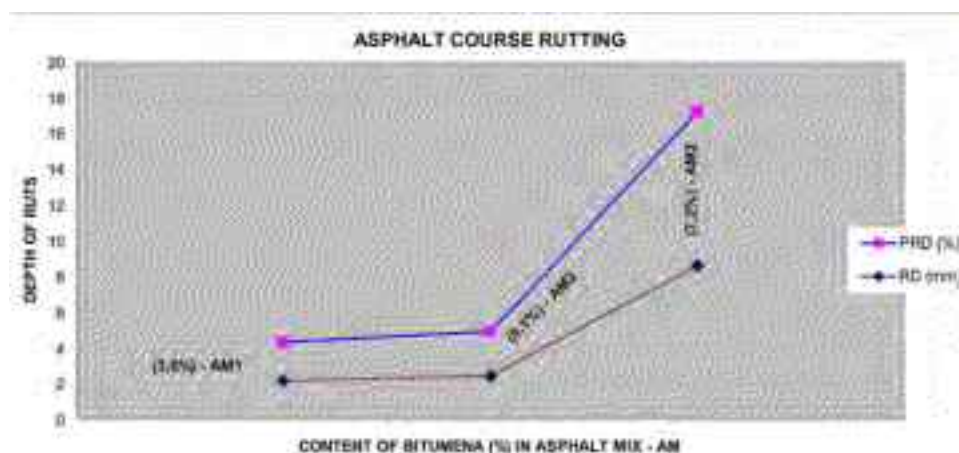

**Figure 3** Dependence of the depth of ruts in asphalt course on share of bitumen

Taking into consideration the share of voids in asphalt mix specimen and determined parameters of rutting depth in tested asphalt courses, it was confirmed that the depth of ruts met requirements in case of specimens of asphalt mix which had the prescribed share of voids (AM3) (figure 4).



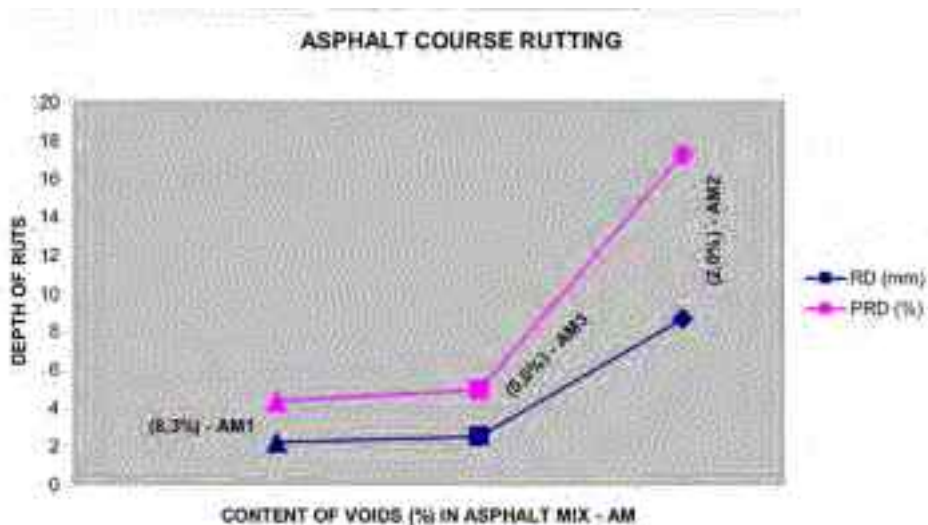

Figure 4 Dependence of the depth of ruts in asphalt course on share of voids

### 3.2 Resistance of asphalt courses / systems to rutting

The research was continued by testing of optimised composition of asphalt mix (AM4-optimum) to resistance to rutting in courses and asphalt-waterproofing systems of different thicknesses.

The following combinations were prepared and tested:

- Single 50 mm thick asphalt course,
- Double asphalt course of total thickness of 75 mm (40+35),
- Double asphalt course of total thickness of 100 mm (50+50),
- Single 35 mm thick asphalt course on top of a waterproofing layer (2mm) and 38 mm thick concrete slab,
- Double asphalt course of total thickness of 60 mm (30+30) on top of a waterproofing layer (2mm) and 38 mm thick concrete slab.

System specimens were prepared by execution of waterproofing layers (epoxy + polyurethane with bitumen) on top of 305×305×38 mm large concrete slabs. Asphalt courses were executed subsequently in moulds of appropriate height, using roller compactor. Steel moulds were used, of 305×305 mm large plan area and of height of 50, 75 and 100 millimetres. Figure 5 presents determined values of rutting parameters (RD and PRD) for tested thicknesses of single or double asphalt courses, executed individually or in waterproofing system on concrete slabs. The best resistance to rutting was determined in double asphalt course of total thickness of 50+50 mm, and the lowest resistance to rutting was determined in a single asphalt course of minimal technological thickness of 35 mm, executed on top of waterproofing layer\* and concrete slab\*\*. Double asphalt course of minimal technological thickness of 30+30 mm in waterproofing system shows lower resistance to rutting than a single 50 mm thick asphalt course or a double asphalt course of total thickness of 75 mm. It is obvious that waterproofing has a significant influence to the decreasing of asphalt resistance to rutting.

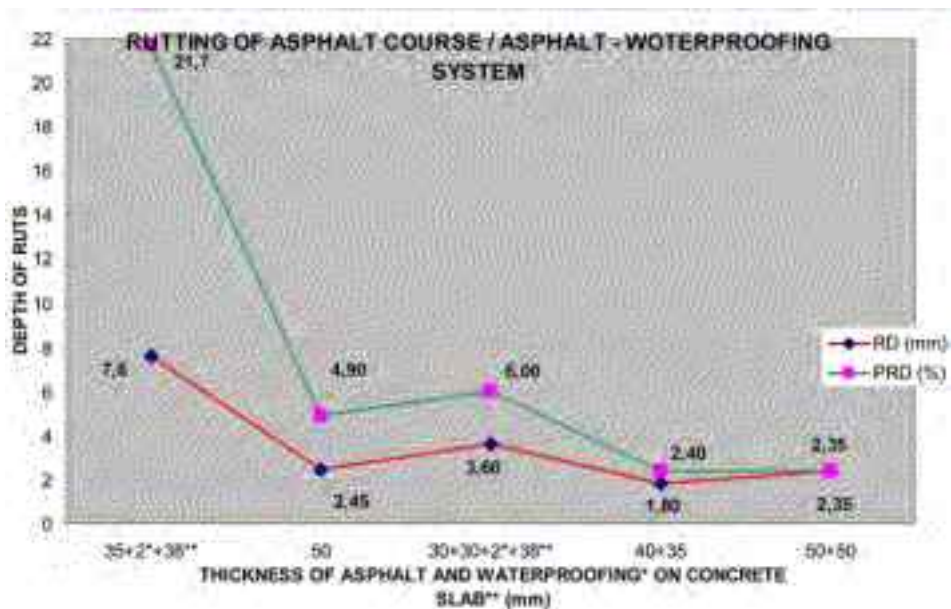

Figure 5 Dependence of depth of ruts on thickness of asphalt/waterproofing systems

#### 4 Conclusion

The research confirmed the established experience that asphalt mix of optimum composition and prescribed physical-mechanical properties meets requirements of resistance of asphalt courses to permanent deformities in the form of rutting. Application of standardised testing method in testing of asphalt resistance to rutting serves for determination of required quality and durability of asphalt pavement. Application of this method of laboratory testing results in rationalisation, i.e. optimisation, of composition and properties of asphalt mix, taking into consideration the expected exploitation properties of pavement structure.

Influence of waterproofing in asphalt-waterproofing systems to reduction of rutting resistance urges caution in designing of pavements on bridges. The behaviour of asphalt in systems such as those executed in pavement structures of bridges, as well as the influence of waterproofing layers which are predominantly bitumen-based, have a significant influence to the exploitation level of pavement surface of a certain road.

Further research shall be directed to testing of possible improvement of asphalt-waterproofing systems' resistance to occurrence of permanent deformities through usage of polymer-modified bitumen.

## References

- [1] Strineka, A.: Utjecaj sastava bitumenskog morta na deformabilnost asfalta, Disertacija na Fakultetu kemijskog inženjerstva i tehnologije, Sveučilište u Zagrebu, 2010. /Impact of bitumen mortar composition to deformability of asphalt, Dissertation at the Faculty of Chemical Engineering and Technology, University of Zagreb, 2010/
- [2] Ramljak, Z.: Bitumen Content Calculation in Designed Asphalt Mixture, Proceedings of 2nd Euroasphalt and Eurobitumen Congress, Barcelona 2000., pp. 704
- [3] Strineka, A.: Svojstva asfalta u ovisnosti o njegovom sastavu, Magistarski rad, Zagreb, svibanj 2005. /Asphalt properties depending of asphalt composition, Master Paper, Zagreb, May 2005/
- [4] HRN EN 12697-8:2003 Bituminous mixtures. Test methods for hot mix asphalt – Part 8: Determination of void characteristics of bituminous specimens
- [5] HRN EN 12697-22 Bituminous mixtures. Test methods for hot mix asphalt – Part 22: Rutting.
- [6] General Technical Conditions for Road Construction, Volume III Pavement Structure, Civil Engineering Institute, Zagreb 2001.
- [7] Technical Regulation for Asphalt Pavement Courses, Ministry of Environmental and Nature Protection, elaboration in progress

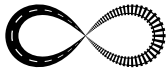

## APPLICATION OF INFRARED CAMERA FOR QUALITY CONTROL DURING PAVING

Bojan Milovanovic, Josipa Domitrovic, Tatjana Rukavina  
*University of Zagreb, Faculty of Civil Engineering, Croatia*

### Abstract

Segregation in asphalt pavements is one of the most common and costly problems in the paving industry. This paper deals with the thermal segregation of hot mix asphalt (HMA) pavement.

HMA is produced and placed at high temperatures (e.g. 155 – 163°C and 140 – 155°C, respectively) and is therefore subject to thermal segregation due to differential cooling, which typically occurs during transport of HMA material and construction of pavement. If the temperature of the asphalt material is not consistent, pavement will eventually show signs of temperature differential damage (TDD) in the locations of the cold spots. Construction-related temperature differentials are large material temperature differences resulting from placement of a significantly cooler portion of HMA material into the new pavement. Placement of this cooler material can create areas near or below cessation temperature (commonly taken as 80°C) which tend to resist adequate compaction. These isolated cooler areas do not fulfil asphalt layer density requirements.

The objective of this study was to utilize an infrared camera to identify thermal segregation in asphalt pavements during construction and possible causes of the temperature differentials which affect compaction and lead to premature distress of the pavement. Temperature data was obtained using an infrared camera (thermal sensitivity 60 mK, geometric resolution 640x480 pixels, FOV 24°) at the paving site. Infrared camera was able to clearly discern cool areas of uncompacted and compacted asphalt material, as well as to determine the temperatures of loose mix in trucks and pavers.

*Keywords: thermal segregation, temperature differentials, pavement distress, cessation temperature, infrared camera*

### 1 Introduction

The benefits of hot mix asphalt (HMA) range from its high performance and environmental friendliness to its low cost. Thus, today HMA is engineer's material of choice for pavement construction of most traffic areas (low and heavy duty roads, runways, bridges, parking lots, driveways etc.).

Since the laid down of the first 'true' asphalt pavement in 1870 (Newark, New Jersey) till today, the production and placement of asphalt pavement has evolved from hand mixing and manual placement with rakes and shovels to computerized plants and automated remixing, placement and compaction equipment. During this time, it has been recognized that mix temperature is critical factor affecting aggregate coating, mix stability during production and transport, ease of placement and compaction as well as the performance of the finished pavement.

HMA temperature has a direct effect on the viscosity of the bitumen, and thus compaction. As the HMA temperature decreases, bitumen becomes more viscous, which result in a smaller reduction in air voids for a given compactive effort [1]. Thus, for successful construction of asphalt pavement, each step in production and placement of HMA must be accomplished within the proper temperature range.

If the mix temperature is inconsistent the degree of compaction (i.e. density) can vary, which will ultimately result in poor performance of finished pavement. Research conducted in late 1990s [2], has shown that variability in density can be caused by temperature differentials on in-placed HMA pavement. This discovery introduced the concept of HMA thermal segregation. Thermal segregation is generally considered difficult to identify by visual inspection, so the potential of using a thermal camera in identifying areas of fresh laid HMA pavement that have substantial temperature differentials has been examined.

Ability of infrared camera to detect temperature of HMA material in paving machinery as well as on large pavement areas makes it suitable tool for quality control during paving.

## 2 HMA Compaction

Compaction is a process that reduces the volume of mix by the application of external forces to form a dense mass [3]. Compaction of HMA is necessary to achieve optimum air-void content (i.e. density) and to increase the load-bearing capacity of the pavement. Previous studies have shown that for every 1% increase in air void, road life is reduced by 10% [4]. Therefore, improper compaction leads to pavement premature failure, mostly due to permanent deformation, ravelling, cracking and moisture damage.

### 2.1 Factors affecting HMA compaction

HMA compaction is influenced by numerous factors, some related to the environment, some determined by mix and structural design and some under contractor control during construction (table 1) [5]. Among them most critical seems to be those that influence HMA temperature and cool-down rate. These are production temperature, haul time and distance, initial mat temperature, mat thickness, temperature of the surface on which the mat is placed, ambient temperature and wind speed [1].

**Table 1** Factors affecting compaction [5]

Environmental Factors	Mix Property Factors	Construction Factors
<b>Temperature</b>	<b>Aggregate</b>	<b>Rollers</b>
– Ground temperature	– Gradation	– Type
– Air temperature	– Size	– Number
– Wind speed	– Shape	– Speed and timing
– Solar flux	– Fracture faces	– Number of passes
	– Volume	– Lift thickness
	<b>Bitumen</b>	<b>Other</b>
	– Chemical properties	– HMA production temperature
	– Physical properties	– Haul distance
	– Amount	– Haul time
		– Foundation support

### 2.2 HMA temperature

The upper temperature limit for production of HMA is approximately 175°C [6]. Higher production temperatures may result in damage to the asphalt. During transportation from plant to construction site mix will cool down. Cool-down rate depends on environmental condi-

tions (air temperature, wind speed), haul time and distance. After the mix is placed rate of cooling depends not only on air temperature and wind speed but also on the base (ground) temperature and the thickness of in-place layer. Temperature of the placed mix is lost in two directions downward into the base and upward into the air. As HMA temperature decreases mix becomes more viscous and resistant to deformations, which results in smaller air-void reduction. If HMA cools below cessation temperature (80°C) it becomes so stiff that additional rolling is ineffective.

Within these limits (80°C–175°C), the best temperature to begin compaction is the maximum temperature at which the mix will support the roller without damaging the mix (e.g. horizontal movement, mix sticking to roller, etc.) [6]. The temperature between 120°C and 175°C will enable the achievement of maximum density at initial phase of rolling (breakdown rolling). The compaction (intermediate rolling) should be completed before HMA temperature drops below cessation temperature. After that rollers can still operate to provide smooth riding surface but without any additional compaction. This is the last phase of rolling (finish rolling) that normally takes place within the temperature range of 85°C to 70°C [7].

Required compaction can be accomplished only if temperature of placed HMA is higher than 80°C and temperature differentials are not greater than 14°C [8]. Due to numerous factors affecting HMA temperature this is very difficult to achieve. Thus, HMA is subject to thermal segregation, i.e. occurrence of temperature differential damage.

### 3 HMA thermal segregation

One of the most common and costly problems in the paving industry associated with HMA pavement is segregation. Segregation is defined as '...lack of homogeneity in the hot mix asphalt constituents of the in-place mat of such a magnitude that there is a reasonable expectation of accelerated pavement distress(es).' [9]. Constituents should be interpreted as bitumen, aggregates, additives, and air voids. Segregation is generally put in two categories, one is aggregate segregation and the other is thermal segregation which will be described below.

Thermal segregation also known as temperature differential damage (TDD) is a form of segregation that occurs during the construction of HMA pavement, and it is result of placing portion of cooler HMA material into the new pavement. Cooler material tends to resist compaction creating pavement areas of low density and high air void content that are prone to distresses like raveling, moisture damage, cracking, etc. Cooling of material within the transport truck and improper paver operation are two main reasons for the appearance of temperature differentials in HMA. During transport from the plant to the construction site material closest to the exterior walls of the truck cools of at a higher rate than material towards the center of the truck. When HMA is loaded into the paver colder material collects on the wings located at the sides of paver hopper. Thus, is longer exposed to ambient temperatures and is usually dumped at the end of the load resulting in areas of temperature differentials in new pavement ('end of load segregation'). Besides this, temperature differentials in the pavement may originate from the colder crust formed on the top of the loose mix during transportation. Although colder material from the crust and hot interior material are remixed in paver hopper, time that HMA stays in the paver is insufficient to achieve uniform temperature before placement.

Thermal segregation, resulting from any of above mentioned reasons appears in three patterns, cold spots, cold runs or V-shaped segregation [10]. Cold spots are localized circular areas of low temperature material. Cold runs can be described as long and narrow bands of cooler martial that runs parallel to the direction of paving. V-shape segregation is cooler material that cyclically occurs at the end of truckload.

Pavements areas that exhibit thermal segregation are not always visually apparent and are not easily noticeable during construction. Therefore, traditional means of detecting segregation, may not work when thermal segregation is an issue. Because of this, infrared camera has been recognized as an effective tool in identifying thermal segregation during construction.

## 4 Quality control during paving

Currently applicable regulations in Croatia prescribe control of HMA temperature during construction in accordance with EN 12697-13. According to this standard HMA temperature must be measured after mixing and during storage, transportation and placement with contact measuring devices (e.g. thermometers) at each HMA sampling point. Data obtained in such manner give information about temperature at selected points, thus areas of low temperature can easily be missed. If the quality control is performed on this way it is very likely that areas affected by thermal segregation will not be detected.

An alternative to thermometers is infrared camera that has the ability to give continuous plot of temperatures. Infrared camera can be applied as a means of quality control in all processes that require the participation of thermal energy. As all objects emit thermal energy in the form of heat, which can be detected by infrared sensor, with infrared camera it is possible to gain a visual image of temperature distribution on large areas. Temperatures are record and displayed as thermograms i.e. colored images with reference scale. Thus, infrared camera could identify areas of different HMA temperature at load out, in the truck during transportation and prior to dumping, in the paver, behind the paver prior to compaction, as well as during compaction.

## 5 Field measurements

As already mentioned, the objective of presented study was to utilize an infrared camera to identify temperature differentials in HMA pavement which could affect compaction and lead to premature distress of the pavement.

The measurements were performed on June 18<sup>th</sup>, 2011 between midnight and 03.30 am. The air temperature during the examination was 13°C at the beginning of the test and dropped to 10°C towards the end of testing. The sky was cloudy and it started to rain slightly at the end of testing, which caused the termination of the paving process.

Temperature data was obtained using an FLIR P640 infrared camera (thermal sensitivity 60 mK, geometric resolution 640x480 pixels, FOV 24°).

Infrared camera was used to determine the temperature of the HMA during dumping process in order to estimate the possibility of its proper placement. Figure 1 shows the HMA mix in the truck at the beginning of the dumping process to the paver.

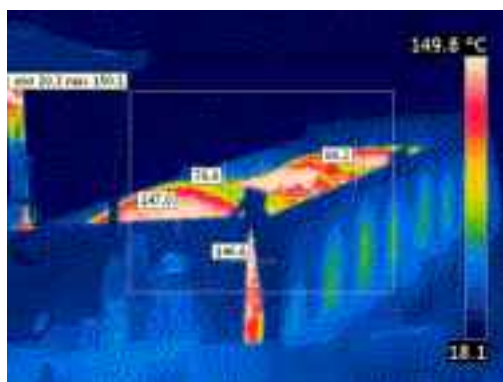
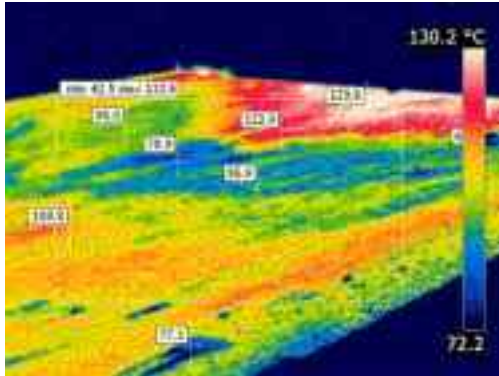

Figure 1 Thermogram of the beginning of HMA mix dump into the paver

From the figure, it can be seen that cold crust formed on the top of the HMA, the temperature of the cold crust is between 76.6 and 86.2 °C while the temperature of the HMA below the cold crust was 147°C. Thermogram shows that HMA of cooler temperatures is being dumped

into the paver; this creates pavement temperatures near cessation temperature. In the case of this specific site, the reason why the cold crust was formed was waiting time before the HMA could be dumped to the paver, since haul distance was very short it didn't influence as much. After the paving, cool areas of uncompacted and compacted HMA were clearly discerned at the paving site, figures 2 and 3.



**Figure 2** Thermogram showing V-shaped thermal segregation

Figure 2 shows the characteristic V-shaped thermal segregation pattern that cyclically appears in the pavement after the end of dumping and with the change of trucks. The temperatures measured were very close to cessation temperature (80°C), in few places even lower (78.9°C). With the additional cooling of the HMA before finishing of the compaction process, the sufficient compaction of the pavement will not be achieved.

Figure 3, shows the area of uncompacted HMA mix with minimal thermal differentials over the whole encompassed surface. The minimal measured temperature is higher than 100°C. The temperature gradient over the surface is 15°C, while lower temperatures are found only on the edges of paved surface where crumbled over spilled material was pushed back in the area that will be compacted.

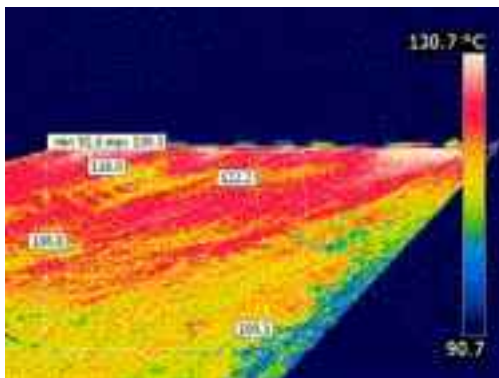

**Figure 3** Thermogram showing minimal thermal differentials in a HMA material

The characteristic of IR thermography is that it can show in real time the distribution of temperatures over a large area, the IR images, thermograms can be saved to serve as a proof of the quality of paving process.



## 6 Conclusion

Negative effects of poor compaction on HMA pavement performance are known for many years. Even with the perfect design, if HMA is not properly compacted, pavement will not serve its intended purpose throughout its design lifetime. The key factor affecting HMA compaction is mix temperature. Every process during pavement construction (mix production, transport, placement and compaction) needs to be completed within the proper temperature range. In order to avoid occurrence of thermal segregation great attention should be paid to temperature control.

Thermometers have long been used to control HMA temperature, and though they provide accurate data, temperature can be measured only in limited number of selected points, thus low temperature areas are easily missed. To ensure proper quality control is necessary to find new methods that will allow the determination of HMA temperature characteristic on large pavement areas before and during compaction as well as in truck and paver.

As presented in the paper infrared camera allows effective monitoring of HMA temperature variations during entire construction process. Infrared cameras are non-contact devices, relatively fast and simple to use. By measuring temperature during construction process it is possible to detect areas of inadequate temperature and apply appropriate measures to avoid temperature differentials. If combined with GPS device it is possible to map temperature characteristics of the entire pavement and thus identify exact locations of areas that could be subject of thermal segregation.

Current studies indicate that infrared camera is an effective tool that can be applied for quality control during paving. But further researches are needed before infrared camera will be used as a reliable specification.

## References

- [1] Lenz, R.W.: Pavement Design manual, <http://onlinemanuals.txdot.gov/txdotmanuals/pdm/compaction.htm#CACJCEHD>, 25.01.2012.
- [2] Willoughby, K.A., Mahoney, J.P., Pierce, L.M., Uhlmeier, J.S., Anderson, K.W., Read, S.A., Muench, S.T., Thompson, T.R., Moore, R.: Construction Related Asphalt Concrete Pavement Temperature Differentials and the Corresponding Density Differentials, Research Report 476.1, Washington State Department of Transportation, Seattle, Washington, 2001.
- [3] Modelling of Hot-Mix Asphalt Compaction, <http://www.fhwa.dot.gov/publications/research/infrastructure/pavements/10065/001.cfm>, 25.01.2012.
- [4] Kumalasari, I.: The Correlation between Degree of Compaction and Performance Life of Asphalt Concrete, Master theses, Universiti Teknologi Petronas, Perak, Malaysia, 2008.
- [5] Factors affecting Compaction, <http://www.pavementinteractive.org/article/factors-affecting-compaction/>, 25.01.2012.
- [6] Roadway Paving Operations, [http://www.ncdot.org/doh/operations/materials/tschedule11/qms\\_manual2011/sect09b.html](http://www.ncdot.org/doh/operations/materials/tschedule11/qms_manual2011/sect09b.html), 26.01.2012.
- [7] Scherocman, J. A.: Compacting Hot - Mix Asphalt Pavement: Part 11, [www.roadsbridges.com](http://www.roadsbridges.com), 25.01.2012.
- [8] McDonald, T.: Why Track Temperature When Paving, [www.forconstructionpros.com](http://www.forconstructionpros.com), 26.01.2012.
- [9] Willoughby, K.A., Mahoney, J.P., Pierce, L.M., Uhlmeier, J.S., Anderson, K.W.: Construction-Related Variability in Mat Density Due to Temperature Differentials, TRB 2003 Annual Meeting, 2003.
- [10] Stroup-Gardiner, M., and Brown, E.R.: Segregation in HMA Pavements, NCHRP Report 441, National Research Council, 2000.
- [11] Putman, B. J., Amirghanian, S. N.: Thermal segregation in asphalt pavements, InfraMation 2006 Proceedings, ITC 115 A 2006-05-22

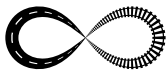

## PAVEMENT SURFACES IN URBAN AREAS

Marijana Cuculić, Sergije Babić, Aleksandra Deluka–Tibljaš, Sanja Šurdonja  
*University of Rijeka, Faculty of Civil Engineering, Croatia*

### Abstract

Areas that were once permeable and moist become impermeable and dry because of urban areas development, and constant construction of city roads and other urban infrastructure. This considerably reduces evaporation, which helps in air temperature reduction. Complex urban geometry prevents the natural wind flow, while the urban canyons absorb solar energy reflected and absorbed by building walls, which further increases the average temperature of urbanized areas in relation to temperature of surrounding rural areas. Research shows that the use of appropriate materials for traffic surfaces and building roofs can reduce the increased warming effect, the so called heat island effect, in the center. Dark materials (e.g. asphalt) are often used in construction and rehabilitation of traffic surfaces without taking into account that they absorb more energy than lighter material (e.g. concrete). All of the above directly affects the formation of urban heat islands. This phenomenon is thoroughly investigated in the U.S., Australia and partially in some European studies and is recognized as a significant environmental problem of cities today.

During the summer of 2011 temperature tests were made on different types of pavement surfacing, on pedestrian and other roads in the Rijeka city centre. This paper will present the results concerning the temperature of different types of road surface that are commonly found in city centres, such as asphalt, stone, concrete surfaces and land surfaces. Tests were conducted during the summer months when the road surface temperature is reaching its peak. The behaviour of these surfaces considering sunlight, colour and traffic load will be analyzed and a comparison with air temperature will be shown. A result analysis will be used to define the possible heat island effect reduction measures.

*Keywords: pavement surfaces, urban areas, temperature, asphalt, concrete*

### 1 Introduction

Modern urban areas are characterized by dark surfaces and less vegetation. This great amount of asphalt, concrete, stone and other similar surfaces absorbs a greater proportion of solar radiation during the day which is reradiated during the night. The result is elevated temperature in urban areas. This temperature difference between urban, suburban and rural areas is what constitutes the urban heat island effect. Roads and parking lots are frequently paved with asphalt that absorbs most of the solar radiation. The sun's energy is converted into thermal energy so pavements get hot, heating the air around them and contributing greatly to the urban heat island effect. The use of appropriate materials in heat island reduction is a subject of many studies [1]. Pavements are part of the problem, but pavements can also be part of the solution (Fig. 1). The use of appropriate materials (cool materials) can improve thermal comfort conditions. One of the strategies in solving that problem is usage of 'cool pavements'. Cool pavements include a range of established and emerging technologies that communities are exploring as a part of their heat island reduction efforts. The term currently refers to paving materials that reflect more solar energy, enhance water evaporation, or have

been otherwise modified to remain cooler than conventional pavements. Cool pavements can be created with existing paving technologies (such as asphalt and concrete) as well as newer approaches such as the use of coatings or grass paving [2].

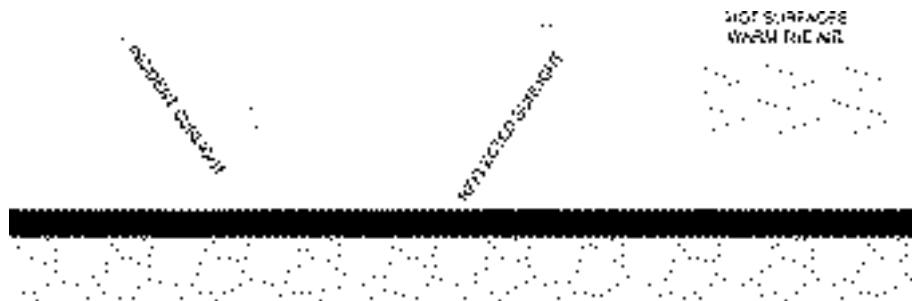

**Figure 1** Behaviour of pavement structures due to incident sunlight

The aim of this paper is to present the results concerning the temperature of different types of pavement surfaces that are commonly found in city centres, such as asphalt, stone and concrete. Tests were conducted during the summer months when the road surface temperature is reaching its peak. The behaviour of these surfaces, considering the sunlight will be analyzed and a comparison with air temperature will be shown. Results analysis will be used to define the possible measures for the heat island effect reduction.

## 2 Thermal properties of cool pavements

The best known characteristic of urban climate is that air temperatures are higher than those in the surrounding rural areas at night. Urban geometry and thermal properties of urban surfaces have been found to be the two main parameters influencing urban climate [3]. The influence of thermal material properties on urban climate will be discussed in this paper. The effect of materials on the temperature of the localized atmosphere is a rapidly expanding research area. Basic research in this area is directed at the material colour and composition and their ability to reflect or absorb (and emit) solar radiation. The colour and composition of the materials greatly affects the temperature of the material exposed to solar radiation. Heat energy from absorbed solar radiation will eventually enter the surrounding atmosphere, causing localized heating [3]. In this sense, albedo and infrared emittance are important material characteristics.

### 2.1 Albedo and infrared emittance

Albedo is a measure of material's solar reflectivity. It is the degree to which material will reflect incoming solar radiation (all light from the sun including infrared, visible and ultraviolet light). Albedo is measured on a scale of 0 to 1. Materials on the low end of the scale absorb solar radiation, while materials on the upper end of the scale reflect solar radiation. Generally, materials that appear to be light-coloured in the visible spectrum have high albedo and those that appear dark-coloured have low albedo (Fig. 2). Because reflectivity in the solar radiation spectrum determines albedo, colour in the visible spectrum is not always a true indicator of albedo [4].

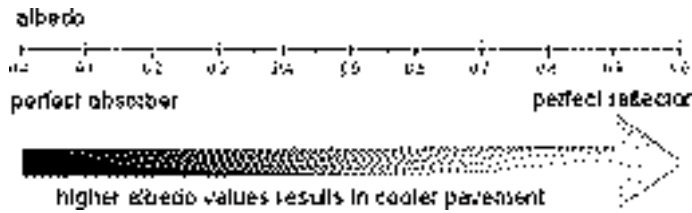

Figure 2 Definition of albedo

Infrared emittance is a measure of the material's ability to release absorbed heat. It specifies how well a material radiates energy away from itself as compared with a black body operating at the same temperature. It is measured on the scale from 0 to 1 [5].

Various studies have been performed for better understanding of thermal and optical performance of materials used for pavements. Asaeda et al. 1996 have reported experimental study results where the impact of different paving materials was tested during the summer period. Results show that surface temperature is significantly higher for asphalt than for concrete and soil. Berg and Quinn 1978 reported that white painted roads with albedo close to 0,55 have almost the same temperature with the ambient environment, while unpainted roads with albedo close to 0,15 were approximately 11°C warmer than air.

### 3 Analysis of pavement surface measurements in the City of Rijeka

The City of Rijeka is the largest Croatian port and the third largest city in Croatia. According to the Kepen classification, the City has moderately warm and humid climate. The average temperature is 13,8°C, which means that the average temperature in January is 5,6°C, while the average temperature in July is 23,3°C.

#### 3.1 Description of locations

During the summer period of 2011 measurements of pavement surface temperature were carried out in the City of Rijeka. 40 different test points in the centre of the City were selected. Test points were on different surfaces (asphalt, concrete, stone...), located in pedestrian areas or areas exposed to vehicle traffic. To determine the influence of insolation, two all day measurements were carried out (12.07.2011. and 15.09.2011.). In total, 80 measurements were carried out at each test point out of which 35 measurement were carried out during the all day measurements. The remaining measurements were carried out during the daily maximum temperatures. Test points were located at one busy street in the City (Riva Boduli), on a pedestrian zone and bus station connection (Jelačić square) and at the main pedestrian zone (Korzo) (Fig. 3).



Figure 3 Location of all test points Riva Boduli street (left), Jelačić square (middle), Korzo (right)

The result of analysis for test points 1 and 3 at Riva Boduli street location, test points 1 and 2 at Jelačić square location and test points 1 and 2 at Korzo location will be discussed. Test points description is given at Table 1.

**Table 1** Test points description

Location	Number of test point	Surface	Traffic load	Period of insolation (12.07. and 15.09.)
Riva Boduli	B1	Stone	Pedestrians	8:30 – 20:30 10:00 – 18:00
Riva Boduli	B3	Concrete	Pedestrians	9:00 – 20:30 10:00 – 18:00
Jelačić square	J1	Asphalt	Vehicle	7:00 – 17:15 8:30 – 16:30
Jelačić square	J2	Concrete	Pedestrians	7:00 – 17:15 8:30 – 16:30
Korzo	K1	Stone	Pedestrians	10:45 – 17:30 9:30 – 13:30
Korzo	K2	Stone	Pedestrians	8:00 – 10:40 8:30 – 9:30

### 3.2 Analysis of the results of pavement surface temperatures

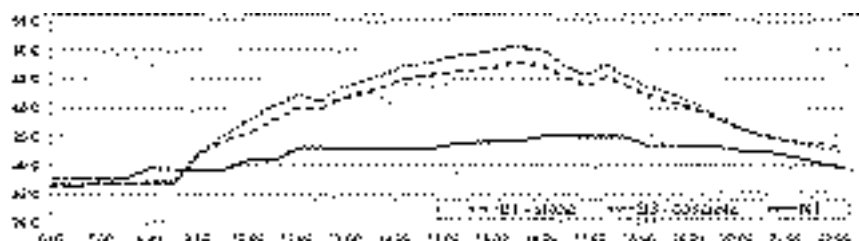

**Figure 4** Daily change of surface and air temperature on stone and concrete (July 2011.)

Fig. 4 shows a daily change of surface and air temperature at test points B1 and B3 during the all day measurement (12.07.2011.). Test point B1 (stone) has the maximum measured temperature of 28,1°C, while the maximum measured temperature at test point B3 (concrete) is 30,8°C. Maximum temperature differences between test points B1 and B3 are 3°C. At the same time temperature difference between test point B1 and air is 13,9°C, while the difference between test point B2 and the air temperature is 15,6°C. Until 9:00am both test points are not exposed to sun radiation and differences in temperature between both test points are minimal and lower than air temperature. Microlocation of test points (proximity of the sea) may cause this phenomenon. From around 9:00am surface temperature of both test points increases and reaches its maximum around 3:30pm. From that point, until around 8:30pm pavement surface temperatures decrease, but the difference between test points B1 and B3 and the difference between individual test point and air is present. In the same time, slower cooling of stone materials is visible, which makes concrete a more suitable material for urban areas usage.

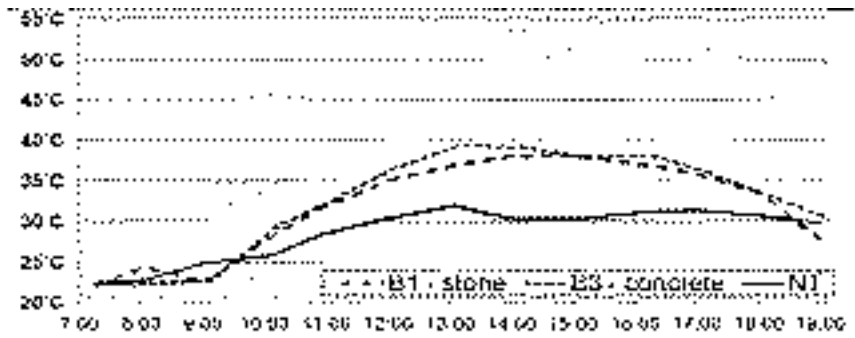

Figure 5 Daily change of surface and air temperature on stone and concrete (September 2011.)

Fig. 5 shows a daily change of surface and air temperature at the same test points (B1 and B3), during the all day measurement (15.09.2011.). Temperature increment shows the same trend like the measurements on 12.07.2011. do. The differences are in maximum measured temperatures which are around 10°C lower than the ones measured on 12.07.2011. At around 2:00pm a decrease in temperatures is recorded. It is evident, from Fig. 4, that summer temperatures reach their maximum at around 3:30pm, while autumn maximums (Fig. 5) occur earlier, around 2:00pm.

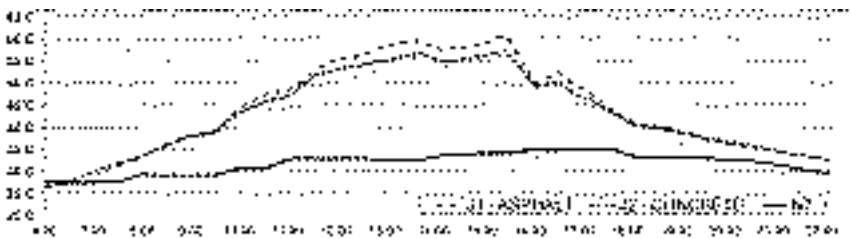

Figure 6 Daily change of surface and air temperature on asphalt and concrete (July 2011.)

Fig. 6 shows a daily change of surface and air temperature at test points J1 and J2 during the all day measurement (12.07.2011.). Test points are located at a bus station and pedestrian zone conjunction. Test point J1 (asphalt) has the maximum measured temperature of 60,9°C, while the test point J2 (concrete) has 3,6°C lower temperature and even 26,7°C lower air temperature at the same time. Even with the usage of insolation materials, the surfaces behave similarly, although the temperature of the asphalt surface is higher than the concrete surface temperature.

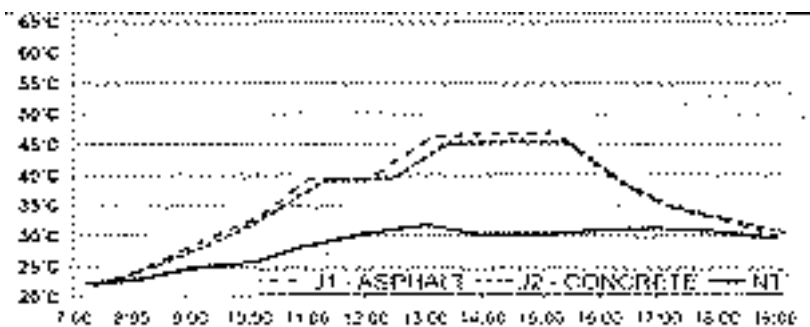

Figure 7 Daily change of surface and air temperature on asphalt and concrete (September 2011.)

Fig. 7 shows a daily change of surface and air temperature at the same test points (J1 and J2) during the all day measurement (15.09.2011.). Temperature increment shows a similar trend to the measurements conducted on 12.07.2011. The differences are in maximum measured temperatures which are, for asphalt, nearly 14°C lower than in summer period. The maximum temperature differences of both test points are minor (around 1°C) and period of maximum differences is reduced.

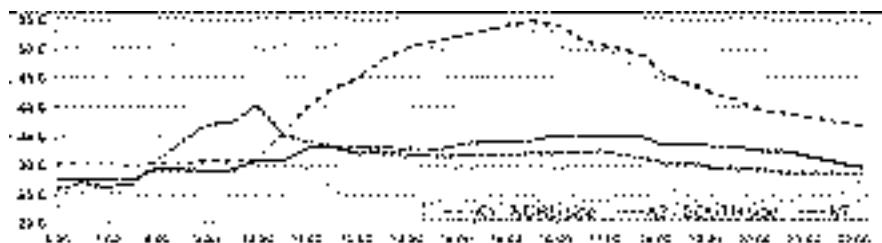

Figure 8 Daily change of surface and air temperature on stone (July 2011.)

Fig. 8 shows a daily change of surface and air temperature at test points K1 and K2 during the all day measurement (12.07.2011.) Test points are located at the main pedestrian zone in the City. The specificity of the test points is different insolation time. Temperature of K1 test point rapidly grows with the appearance of insolation. The maximum measured temperature was 54,8°C. Temperature of K2 test point moderately increases (time of insolation) and the maximum measured temperature was 40,4°C. Insolation period for test point K2 stops at around 10:30am, so the temperature from that point until the end of measurements decreases. In the same period, insolation of test point K1 starts so the temperature from that point rapidly increases. Because of the different period of insolation, temperature differences of test points are pronounced (more than 20°C). From around 12:00am temperature of K2 test point is lower than the air temperature.

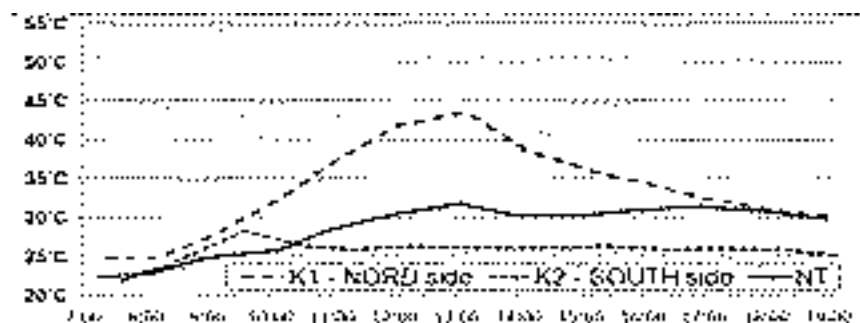

Figure 9 Daily change of surface and air temperature on stone (September 2011.)

Fig. 9 shows a daily change of surface and air temperature at the same test points (K1 and K2) during the all day measurement (15.09.2011.). Temperature increment of both test points shows a similar trend like the measurements in July. Temperature of test point K1 reaches its maximum at around 1:30pm. From that point surface temperature decreases, which is a result of termination of insolation. Test point K2 reaches its maximum at around 9:30am and from that point the reduction in surface temperature is evident. From around 10:30am surface temperature of test point K2 is lower than air temperature. That can be a result of short insolation time.

## 4 Conclusion

The temperature in the City is influenced by a range of factors which we can or can't control. What we certainly can control is the building material. As the pilot study of measuring temperatures in the City of Rijeka shows, major factor effecting the surface temperature is the sun's radiation. One of the strategies to mitigate urban heat island effect is the usage of high albedo surface materials, usage of porous pavements and increment of urban vegetation.

In this paper we presented results of pavement surface temperature measurements conducted during the summer of 2011, in the City of Rijeka. Results indicate that concrete and stone materials achieve lower temperatures in peak hours. Results also indicate that concrete is a more favourable material for usage in city centres, because it showed a lower level of temperature than asphalt, especially in peak hours (test points J1 and J2). Results show that insolation period has a major influence on surface temperatures. Test points that are in shade reach lower surface temperatures than those exposed to insolation.

High temperatures can also cause damage to paving materials. In general, higher temperatures cause materials to expand and then contract as they cool. For concrete this can lead to cracking and even failure. For asphalt this can cause rutting and other surface deformation. Extra research is needed to further analyze characteristic of pavement materials and to highlight the benefits of using cool materials from the point of life quality but also the increment of durability of materials sensitive to temperature change.

## References

- [1] Akbari H., Pomwerantz M., & Taha H.: Cool surfaces and shade trees to reduce energy use and improve air quality in urban areas, *Solar Energy*, Vol. 70/3, pp. 295 – 310, 2001.
- [2] United States Environmental Protection Agency: Reducing Urban Heat Islands: Compendium of Strategies Cool Pavements, Epa, Washington Dc, 2008.
- [3] Oke, T.R., Johnson, G.T., Steyn, D.G. and Watson, I.D.: Simulation of surface urban heat islands under ideal conditions at night. Part 2. Diagnosis of causation, *Boundary-layer Meteorology*, Vol 56, pp 258 – 339, 1991
- [4] Gadjia, J.W. & VanGeem, M.G.: A Comparison of Six Environmental Impacts of Portland Cement Concrete and Asphalt Cement Concrete Pavements, PCA R&D, SN 2068, Illinois, USA, 2001.
- [5] Santamouris, M., Synnefa, T. & Karlessi, T: Using advanced cool materials in the urban built environment to mitigate heat islands and improve thermal comfort conditions, *Solar Energy*, Vol. 85/12, pp. 3085-3102, 2011.





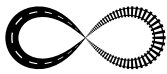

## PERMANENT DEFORMATIONS OF ASPHALT MIXTURES FROM PAVEMENT WEARING COURSES

Adrian Burlacu, Carmen Răcănel

*Technical University of Civil Engineering of Bucharest, Romania*

### Abstract

Asphalt mixture is a highly flexible material in road structures. Depending on the layer used: the base layer or wearing course, it must respond to loads coming from the traffic and climate. Asphalt mixture on the wearing course must take tangential forces produced by vehicle's wheels and to transmit vertical loads to the bottom layers, to support loads from climate factors, to provide sufficient rigidity so as to contribute to road structure resistance increase, to be waterproof and with enough roughness, to drain runoff. Because of traffic increment and climate changes, degradations like permanent deformations, fatigue cracking and low temperature cracking appear on flexible asphalt pavements. These degradations reduce road structures life time and increase maintenance costs.

The present paper aims to highlight the laboratory measurements of one of the asphalt mixture characteristics, namely the dynamic creep test studying the influence of loading conditions on the values obtained. The results obtained from calculus are presented as influence graphs.

*Keywords: asphalt mixture, permanent deformations, dynamic creep, creep modulus, creep rate*

### 1 Introduction

With an increasing demand in road's construction, engineers are constantly trying to improve the performance of bitumen pavement. In recent years, with the increase of traffic combined with various environmental effects, the road surfaces have been exposed to high loads that cause constant and excessive stress that leads to permanent deformation.

In an asphalt mixture bitumen links the aggregates, providing some stability and ensuring resistance from traffic and environment efforts, so that asphalt mixture performance is a function of bitumen properties, aggregate and volumetric properties of the mixture.

Dynamic tests developed over time study the state of stress and strain in the road structure under external loads (traffic, temperature). Thus the origin of degradation is established and after that the understanding of the propagation degradation mechanism.

### 2 Research objective

The goal of this paper is to test the new polymer–modified bitumen that is recommended for asphalt mixtures in wearing courses. Effective binder specification should be based on a mixture behaviour scale. The benefits of using the new polymer–asphalt mixture, in comparison with other asphalt mixtures, are in loading conditions referring to rutting, one of the main flexible pavement distress.

This study was carried out in Roads Laboratory of Faculty of Railways, Roads and Bridges (Technical University of Civil Engineering of Bucharest).

### 3 Materials and asphalt mixture recipes

In order to achieve the goal, two wearing course asphalt mixtures were chosen: high modulus asphalt mixture (MAMR16) and stone mastic asphalt (MASF16) with three types of binders, noted from A to C. Both asphalt mixtures were designed in accordance with national and European norms with C type bitumen. Bitumen A and C are polymer–modified binders and bitumen B is an original one, used as a base for the C type bitumen. The A and B bitumen types have similar penetration class. Another part of the study consists of changing the fibre type for MASF16 mixture with c bitumen, the cellulose fibre was replaced with polypropylene fibre. The materials (aggregates, fibre and bitumen) used to prepare the asphalt mixtures and the asphalt mixtures recipes are presented in Table 1 and 2.

**Table 1** The used asphalt mixtures materials and the recipes for the used asphalt mixtures

Asphalt Mixture	Source /type and %	Crushed Stone			Filler	Fibre by Mixture	Bitumen by Mixture
		8/16	4/8	0/4			
MAMR16	Source /type	Reväsarsarea			Limestone - Holcim	-	A: 45/85-65 PMB B: 50/70 C: 25/55-65 PMB
	%	35	29	25	11	-	4.12
MASF16	Source /type	Turcoaia			Limestone Holcim	Topcel	A: 45/85-65 PMB B: 50/70 C: 25/55-65 PMB
	%	45	25	13	11	0.3	5.7
MASF16	Source /type	Turcoaia			Limestone Holcim	Polypropylene	C: 25/55-65 PMB
	%	45	25	13	11	0.3	5.7

**Table 2** Bitumen properties

Properties	Bitumen A (Pmb)	Bitumen B	Bitumen C (Pmb)
Penetration at 25°C (0.1mm)	68	64	35
Ring and ball soft point (°C)	83	51	81
Ductility at 25°C, cm	92	>100	95

### 4 Laboratory tests and testing conditions

The following test will be considered in order to compare mixtures characterization against the main distress that occurs in situ–rutting: Triaxial Cyclic Compression test on cylindrical samples according to SR EN 12697-25 test method B: 500C test temperature, 300kPa axial load, 1 bar confining pressure, 1s/1s frequency (block pulse). For MASF16m mixture with polypropylene fibre three temperatures were chosen: 40°C, 50°C, 60°C. Principle of this test is the evaluation of the dynamical creep of test specimens by the three axle compression, where the cylindrical specimen is exposed to a confining pressure, simulating the conditions of a real road, and simultaneously exposed to the vertical cyclic loading, simulating loading from traffic.

MASF16 asphalt mixture bulk density was equal to 2370 Kg/m<sup>3</sup>, and 2550 Kg/m<sup>3</sup> for MAMR16 asphalt mixture.

## 5 Experimental results

The laboratory studies gave experimental results plotted in figures 1 – 6 and presented in tables 1–4. According to the binder type the cumulative axial strain values (figure 1, 2 and 5, table 1 and 2) and creep modulus (figure 3, 4 and 6, table 3 and 4) for creep behaviour can be highlighted.

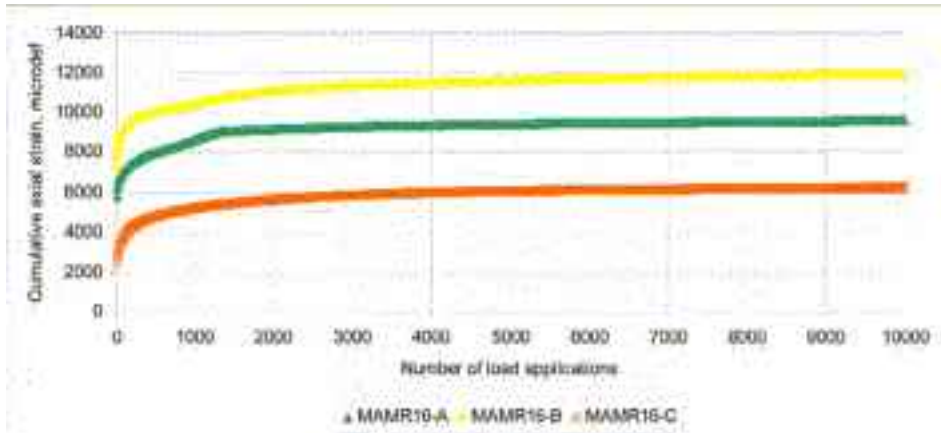

Figure 1 Creep curves for MAMR16 asphalt mixtures

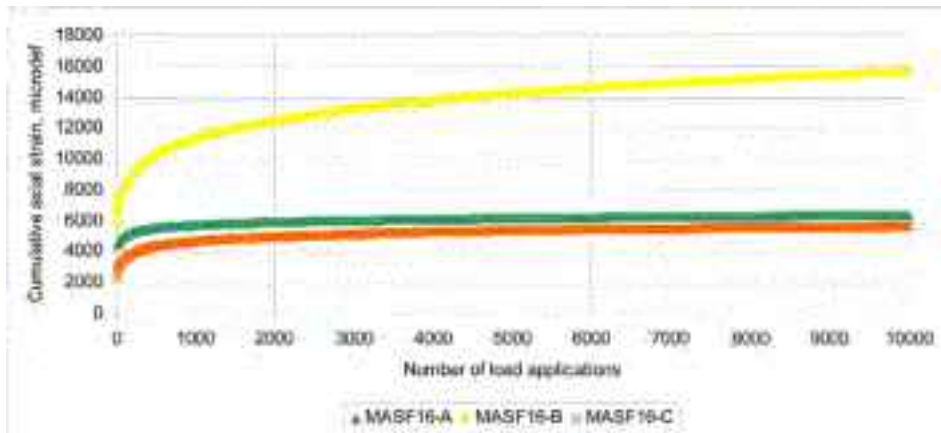

Figure 2 Creep curves for MASF16 asphalt mixtures

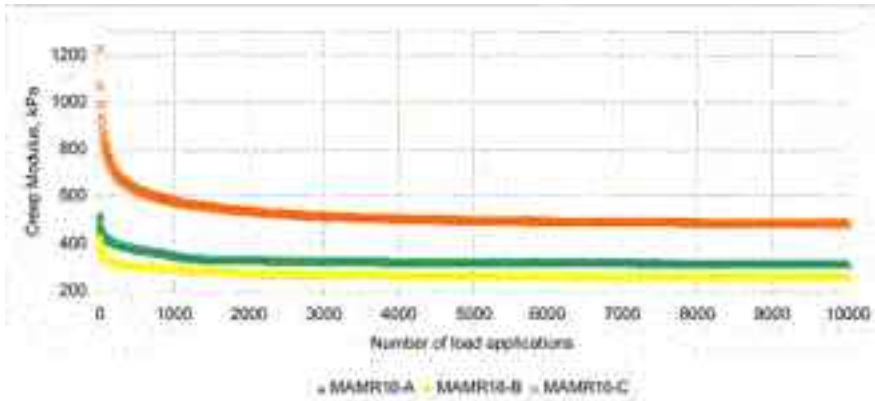

Figure 3 Creep modulus values for MAMR16 asphalt mixtures

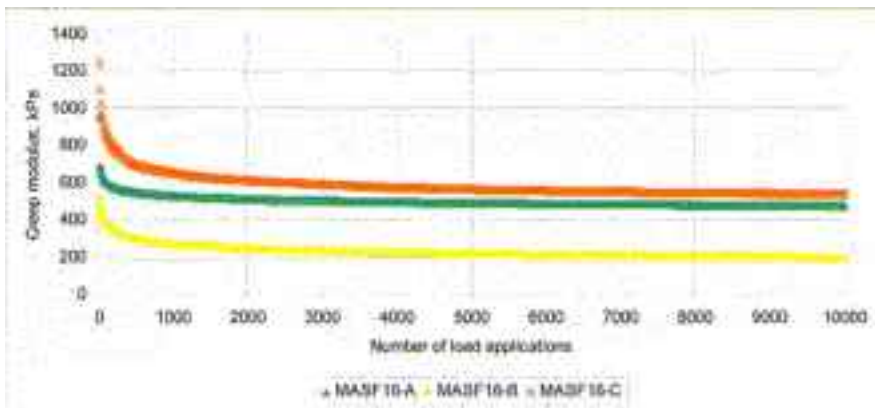

Figure 4 Creep modulus values for MASF16 asphalt mixtures

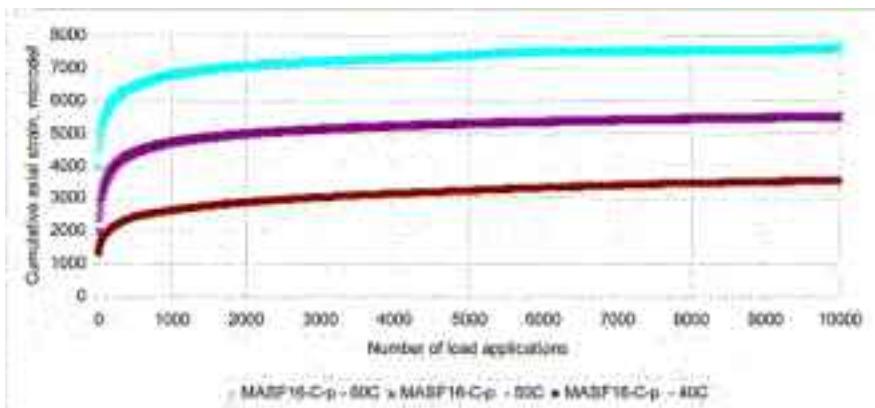

Figure 5 Creep curves for MASF16 – C with polypropylene asphalt mixture at different temperatures

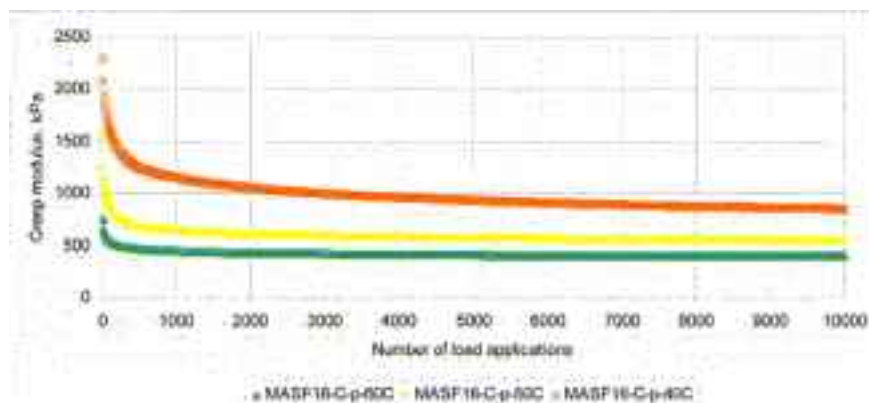

Figure 6 Creep modulus values for MASF16 – C with polypropylene asphalt mixture at different temperatures

Table 3 Creep results, method I and creep modulus values

Type of Mixture	Parameters of equation on (quasi) linear stage II Method I ( $\epsilon_n = A_1 + B_1 n$ )		Creep rate $f_c = B_1$	Creep modulus, $E_n = \sigma / \epsilon_n$ , kPa		
	A1	B1		initial	1000	10000
MAMR16-A	9252.7	0.0349	0.0349	518	348	313
MAMR16-B	11307	0.0615	0.0615	418	291	252
MAMR16-C	5895.1	0.0333	0.0333	1227	579	482
MASF16-A	5951.7	0.0386	0.0386	961	527	474
MASF16-B	12837	0.2835	0.2835	512	266	192
MASF16-C	5129.1	0.0478	0.0478	1243	649	536
MASF16-C, p-40oC	2941.9	0.0607	0.0607	2298	1146	850
MASF16-C, p-50oC	5100.6	0.0409	0.0409	1528	636	545
MASF16-C, p-60oC	7296.2	0.029	0.029	753	442	394

Table 4 Creep results, method II

Mixture type	Parameters of Equation on (quasi) Linear Stage II Method II ( $\log \epsilon_n = \log A + B \log n$ )		Calculated Permanent Deformation $\epsilon_{1000}$ : $\epsilon_{1000,calc} = A1000^B$	Calculated Permanent Deformation $\epsilon_{10000}$ : $\epsilon_{10000,calc} = A10000^B$
	A	B		
MAMR16-A	7497.22	0.0268	9022	9596
MAMR16-B	8357.95	0.038	10867	11860
MAMR16-C	4314.2	0.0397	5675	6219
MASF16-A	4167.73	0.0454	5703	6331
MASF16-B	4339.1	0.139	11334	15610
MASF16-C	3096.71	0.0643	4828	5599
MASF16-C, p-40°C	1048.09	0.1321	2610	3538
MASF16-C, p-50°C	3295.34	0.0556	4838	5499
MASF16-C, p-60°C	5827.74	0.0285	7096	7577

## 6 Conclusions

The conclusions that result from this study are the following:

- a Bitumen type can have significant influence on creep behaviour;
- b Referring to permanent deformation resistance of the studied mixtures the following is taken into consideration: interpretation of the creep curve result, the creep rate ( $f_c$ ), the creep modulus ( $E_n$ ), the calculated permanent deformation after 1000 and 10000 cycles ( $\epsilon_{1000,calc}$ ,  $\epsilon_{10000,calc}$ ) and the slope from the least square linear fit (B parameter):
  - Creep rate rise for MAMR16 asphalt mixture with 80% passing from polymer modified binder (PmB) A and C to the original binder B; for MASF16 asphalt mixture, values are very closed;
  - Creep modulus value rise with the increment of bitumen rigidity (average 100% for a mixture with bitumen PmB C or a mixture with bitumen PmB B) and decreases with the increment of applied loads number in accordance with bitumen type and mixture recipe (average 2.5 times for MASF16 and 1.6 times for MAMR16, exception MAMR16 with bitumen C for which the loss is 2.5 times, similar happens with MASF16);
  - Permanent deformation calculated after 1000 cycles and after 10000 cycles decreases with bitumen hardening increment; mixture with bitumen PmB A has a better behaviour at permanent deformations comparatively with bitumen PmB B mixture: in case of the MAMR16 mixture values for  $\epsilon_{1000,calc}$  and  $\epsilon_{10000,calc}$  are 10% smaller and 25% smaller in case of the MASF16 mixture; instead, the contribution of the modified bitumen A can be seen in comparance with the original bitumen B: loss of deformation by average 50% in case of using the bitumen PmB A and C;
- c As it can be seen, for a good creep behaviour of an asphalt mixture, using polypropylene fibre can be a good option, (at the same temperature, the results obtained are better than with cellulose fibre). The improvement of asphalt mixture properties shows the positive effect of polypropylene fibres. Also it can be seen that the increment of testing temperature by 200C results with an increment of  $\epsilon_{1000,calc}$  and  $\epsilon_{10000,calc}$  with 60% and respectively 50%. Temperature rise of 100C from 400C to 500C results in an increment of permanent deformation, in average with 40%, comparatively with the same temperature increasing by 100C from 500C to 600C for which the increment of permanent deformation calculated after 1000 and 10000 cycles is about 30%. Creep modulus decrease with 50% when temperature rises by 200C.

## References

- [1] LCPC Bituminous Mixtures Design Guide. (2007) Laboratoire Central des Ponts et Chaussées, Réseau Scientifique et Technique de l'Équipement
- [2] SR EN 12697/25 -2005. Bituminous mixtures – Test methods for hot mix asphalt – Part 25: Cyclic compression test
- [3] SR EN 13108/1 -2005. Bituminous mixtures – Material specifications – Part 1: Asphalt Concrete
- [4] SR EN 13108/20 -2005. Bituminous mixtures – Material specifications – Part 20: Type testing
- [5] SR 174-2002. Road works.Hot bituminous rolled pavements. Quality requirements
- [6] NF P98-141 Enrobé hydrocarbonés – Couches de roulement et couches de liaison: bétons bitumineux à module élevé
- [7] Răcănel Carmen, Burlacu Adrian 'Influența condițiilor de încărcare pentru încercarea de fluaj dinamic' 'Cercetare, Administrare Rutieră, CAR 2010', 09 iulie 2010
- [8] Răcănel Carmen, Burlacu Adrian, Surlea Claudia 'Laboratory Results Obtained on New Asphalt Mixtures with Polymer Modified Bitumen' 2nd International Conference on Transport Infrastructures, ICTI2010, 4-6 August, 2010 São Paulo, Brazil, ISBN 978-972-8692-57-5 (pg. 85-94)

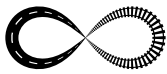

## LABORATORY TESTS CONCERNING FATIGUE BEHAVIOR OF ASPHALT MIXTURES

Carmen Răcănel, Adrian Burlacu

*Technical University of Civil Engineering of Bucharest, Romania*

### Abstract

The study of fatigue behaviour on asphalt mixtures has a particular importance, both to estimate the degradation that can occur during service period in the asphalt layer under external loads (traffic, climate) and to consider the fatigue laws that should be taken into account in asphalt pavement design.

The European Standard adopted in our country, SR EN 13108:20 stipulates some tests for determining fatigue resistance of asphalt mixtures, including the 4PB–PR test (four–point bending test on prismatic samples).

The goal of this paper is to emphasize the results (fatigue resistance and stiffness) obtained in the Road Laboratory of Technical University of Civil Engineering. The results were obtained using some types of asphalt mixtures with the PMB binder (asphalt mixtures used in Romania). Conclusions will be presented in the form of comparative charts.

*Keywords: asphalt mixture, fatigue, stiffness, four point bending test*

## 1 Introduction

### 1.1 Context

Knowing that stiffness and asphalt mixtures response to fatigue is an important issue, those two parameters need to be taken into consideration when designing a pavement structure for a specific traffic calculation.

The stiffness modulus of asphalt mixtures is a fundamental property that gives information about how much the material deforms under a given load. It is closely related with fatigue cracking and permanent deformation because of time and temperature dependence. The stiffness modulus of asphalt mixture is useful for: quality evaluation of the asphalt mixture, asphalt mix design, pavement design and asphalt mixture damage.

In the calculus of a pavement structure, estimating the life duration of an asphalt mixture under fatigue is necessary so that possible re–dimensioning would enable the pavement to resist the heavier traffic.

In the asphalt mixtures fatigue study, two types of controlled load can be applied: constant (controlled) stress and constant (controlled) strain. Under constant stress testing, the effort (stress) remains constant, but the deformation increases with the increase of applied load, while under the constant deformation (strain) test the deformation is maintained constant and the effort decreases with the number of applied load.

The first test type has the advantage of a quick failure so it can be easily defined, while for the constant deformation testing arbitrary failure criteria is frequently used.

For asphalt mixtures stiffness and for their fatigue behaviour, our country adopted a European norm SR EN 13108:20, which requires a conduct of specific laboratory testing. Among the tests



recommended by European norms, the four point bending test (4PB-PR) can be found. It is performed at constant strain (controlled), on prismatic asphalt mixture samples made in the laboratory, using the roller compactor or cores extracted from the asphalt of a road structure.

## 1.2 Objectives

In Romania, concomitant with the European norm SR EN 13108-20 is the Romanian norm SR174 which establishes the requirements regarding the performance of asphalt mixture. So, when we refer to stiffness and fatigue resistance, the Romanian norm imposes the IT-CY test (indirect tensile test performed on cylindrical samples, SR EN 12697-26 annex c and SR EN 12697-24, annex E).

The Roads Laboratory of the Faculty of Railways, Roads and Bridges from Technical University of Civil Engineering of Bucharest, in accordance with the European norms: 2PB-TR, 4PB-PR and IT-CY, is equipped with all of the equipment required for dynamic testing (stiffness and fatigue test) and has years of experience in the conduct of these tests.

The objective of this paper is to present the results (fatigue resistance and stiffness) obtained in the Road Laboratory of Technical University of Civil Engineering on some types of asphalt mixtures used in Romania, most of them containing PMB binder, using the the 4PB-PR test. Therefore, our Romanian asphalt mixtures will be characterised from the stiffness and fatigue resistance point of view, according to European norms SR EN 13108-1 and 13108-5.

## 2 Stiffness and Fatigue test

### 2.1 investigated asphalt mixtures

This study was carried out in the Roads Laboratory of Faculty of Railways, Roads and Bridges (Technical University of Civil Engineering of Bucharest).

Table 1 The used materials in asphalt mixtures and recipes of the used asphalt mixtures

Asphalt Mixtures	Source / Type and %	Crushed Rock				Filler	Fiber by mix	Bitumen by mix
		0-4	4-8	8-16	16-25			
MAMR16	Source / Type	Revarsarea				Limestone Holcim	-	25/55-65 PMB
	%	25	29	35	-	11	-	4.12
MASF16m-T	Source / Type	Turcoaia				Limestone Holcim	Topcel	25/55-65 PMB
	%	13	25	45	-	11	0.3	5.7
MASF16m-P	Source / Type	Turcoaia				Limestone Holcim	Polypropylene	25/55-65 PMB
	%	13	25	45	-	11	0.3	5.7
MASF16m-T-wm	Source / Type	Turcoaia				Limestone Holcim	Topcel	25/55-65 PMB+ additive
	%	13	25	45	-	11	0.3	5.7
BA16	Source / Type	Cerna				Limestone Holcim	-	50/70
	%	32	22	30	-	9.4	-	6.6
BAD25	Source / Type	Turcoaia				Limestone Holcim	-	25/55-65 PMB
	%	31	17	20	23	4.5	-	4.5

Four types of asphalt mixtures frequently used in our country (table 1) were examined: a classic asphalt mixture–type BA16 for wearing course; a classic asphalt mixture – type BAD25 for a binder course, a high modulus asphalt mixture – type MAMR16 and an asphalt mixture with fibre – type MASF16. For the last mixture, two types of fibre were used: topcel and polypropylene as well as two technologies: a hot mix (MASF16m-T) and a warm mix (MASF16m-T-wm). The recipes for studied asphalt mixtures correspond to Romanian norm but are also in accordance with the European norms SR EN 13108-1 and 13108-5.

## 2.2 Sample preparation

The prismatic samples for the 4PB-PR test were manufactured by cutting the required dimensions (50 x 50 x 405 mm) from slabs compacted with roller compactor.

## 2.3 Four Point Bending Test

The four–point bending test 4PB-PR is used to determine the asphalt mixtures stiffness and to evaluate the asphalt mixtures fatigue behaviour and it is performed at constant strain (controlled) in time. The test was made on prismatic asphalt mixture samples submitted to a sinusoidal load. The prismatic beam was subjected to four–point periodic bending, with free rotation and translation at all load and reaction points. During the test, the load bent the sample. The deflection and the phase angle were measured as a function of time. The test is considered finished when the force reaches half of its initial value (Fig. 1). In order to establish the stiffness modulus and the fatigue resistance of asphalt mixtures presented above, the laboratory test was conducted according to the SR EN 13108-20 (table 2 and 3).

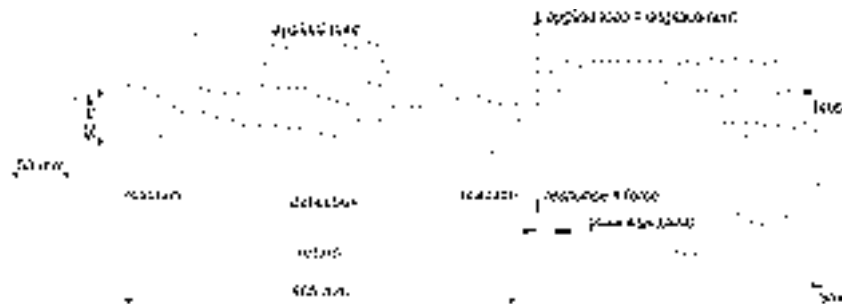

**Figure 1** The four points bending test and the load and response in the case of fatigue apparatus for four points bending test

**Table 2** Requirements regarding determination of asphalt mixture stiffness according to SR EN 13108-20

Type of loading	Temperature	Frequency	Test method
4PB-PR	20oC	8Hz	SR EN 12697-26, annex B

**Table 3** Requirements for measurement of asphalt mixture fatigue according to SR EN 13108-20

Type of loading	Temperature	Frequency	Test method
4PB-PR	30°C	30Hz	SR EN 12697-24, annex D

### 3 Stiffness and fatigue test results

#### 3.1 Stiffness test results

The obtained results for stiffness modulus of the tested asphalt mixtures are presented in Fig. 2. According to the SR EN 13108-1, the stiffness category of these asphalt mixtures is as presented in the table 4.

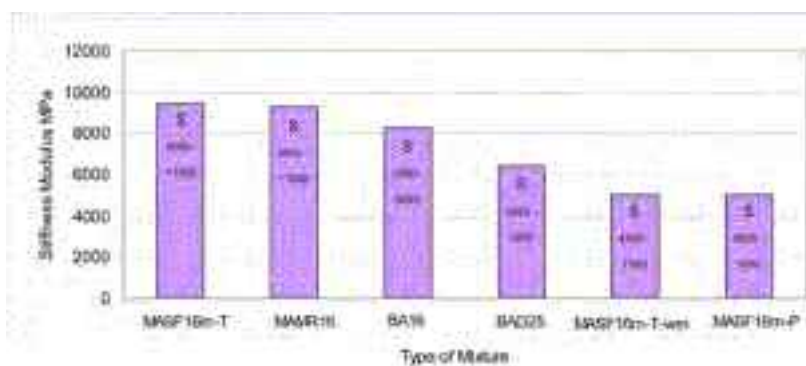

**Figure 2** Stiffness modulus values for different asphalt mixtures gotten from the four point bending test. Temperature: 20°C, frequency: 8Hz

**Table 4** Minimum and Maximum Stiffness, according to the SR EN 13108-1

Type of mixture	Stiffness values, MPa	Stiffness category	
		S <sub>min</sub>	S <sub>max</sub>
MAMR16	9274	9000	11000
MASF16m-T	9452	9000	11000
MASF16m-P	4975	4500	7000
MASF16m-T-wm	4990	4500	7000
BA16	8256	7000	9000
BAD25	6424	5500	7000

#### 3.2 Fatigue test results

The obtained results for fatigue lines of MAMR16, MASF16m, BA16 and BAD25 asphalt mixture are presented in Fig. 3.

The fatigue line has the following shape:

$$\ln N = A_0 + A_1 \ln \varepsilon \quad (1)$$

where:

N is the fatigue life for the chosen failure criteria (number of load cycles);

$\varepsilon$  – the initial strain amplitude measured at the 100th load cycle,  $\mu\varepsilon$ ;

$A_0$  and  $A_1$  – material constants.

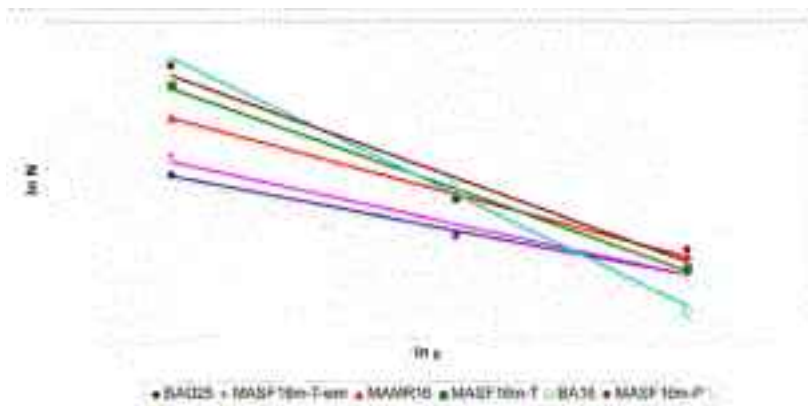

**Figure 3** Fatigue lines from the four point bending test. Temperature: 30°C, frequency: 30Hz

Table 5 gives an overview of material constants, as well as the estimation of the initial deformation for the fracture criteria chosen. For the given testing conditions ( $\epsilon_0$ ), the expected fatigue life is  $10^6$  cycles. The resistance to fatigue category of these asphalt mixtures, concerning the SR EN 13108-1, is also presented in table 5. A comparison of asphalt mixtures from the category  $\epsilon_6$  (resistance to fatigue) is given in Fig. 4.

In Fig. 5 and Fig. 6 the fatigue lines are plotted together, for fatigue resistance comparison between  $\epsilon_6$  specific asphalt mixtures.

**Table 5** Fatigue line characteristics and estimation for  $\epsilon_6$

Type of mixture	$A_0$	$A_1$ or slope 'p' of fatigue line	Correlation coefficient of the regression $R^2$	$\epsilon_0$ , $\mu\epsilon$	Resistance to fatigue category $\epsilon_6$
MAMR16	59.657	-8.5154	0.9997	217	$\epsilon_{6-190}$
MASF16m-T	75.117	-11.293	0.9937	227	$\epsilon_{6-220}$
MASF16m-P	76.268	-11.451	0.9593	233	$\epsilon_{6-220}$
MASF16m-T-wm	49.986	-6.8977	0.9578	189	$\epsilon_{6-160}$
BA16	96.827	-15.248	0.9921	231	$\epsilon_{6-220}$
BAD25	45.032	-6.0302	0.9961	177	$\epsilon_{6-160}$

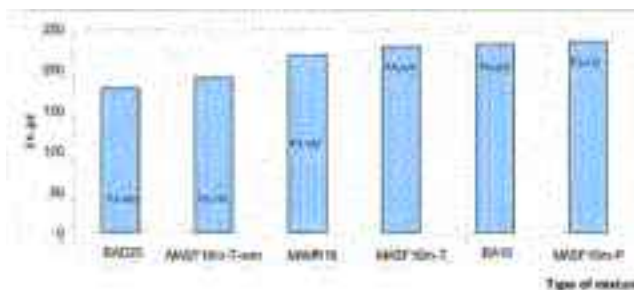

**Figure 4** Category  $\epsilon_6$  for different asphalt mixtures

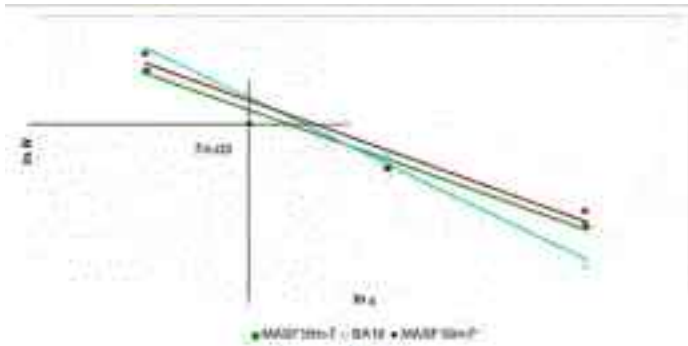

Figure 5 Fatigue lines and fatigue resistance  $\epsilon_f$  for MASF16m-T, MASF16-P and BA16 asphalt mixture

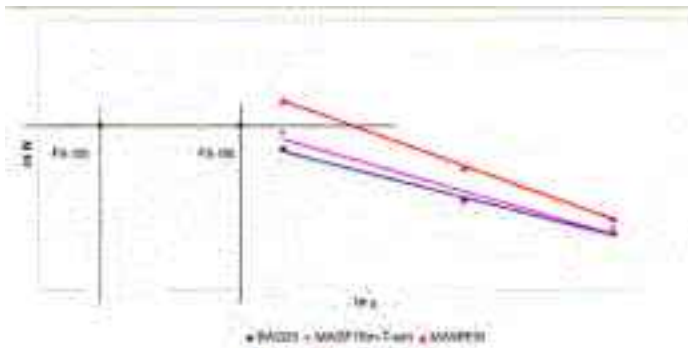

Figure 6 Fatigue lines and fatigue resistance  $\epsilon_f$  for BAD25, MASF16m-T-wm and MAMR16 asphalt mixture

## 4 Conclusions

The study presented above leads to certain conclusions regarding the performance of asphalt mixtures, in terms of category, according to the European norm. The study of asphalt mixture stiffness highlights the fact that different values can be obtained depending on asphalt mixture type. Using a polymer modified bitumen (PMB) and a strong aggregate skeleton (MAMR16 and MASF16m-T mix) results in better asphalt mixture stiffness for mixtures studied ( $S_{9000-11000}$  category). Using an additive in asphalt mixture MASF16m-T-wm we achieved smaller values of stiffness than asphalt concrete MASF16m-T. The same conclusion is valid for polypropylene fibre in asphalt mixture, MASF16m-P ( $S_{4500-7000}$  category).

Regarding the study of fatigue behaviour it can be said that asphalt mixture with fibre - MASF16m-T has a specific strain corresponding to one million cycles  $\epsilon_f$ , which is superior to other studied mixtures. The studied asphalt mixtures are classified in three categories, based on the fatigue resistance:  $\epsilon_{6-220}$ ,  $\epsilon_{6-190}$  and  $\epsilon_{6-160}$ . Mixtures with high stiffness are in the first category, like MASF16m-T along with mixtures with low stiffness, like MASF16m-P. The asphalt mixture stiffness affects the slope and the position of the fatigue line. The number of cycles necessary to reach fatigue decreases with the increase of stiffness modulus.

From all the studied asphalt mixtures, MASF16m-T-wm mix type has the worst fatigue behaviour, which is in correlation with its low stiffness. Since this is a warm mixture, the benefits for asphalt industry must be taken into account: helping the compaction of stiff mixes, prolonging the paving season (in cold weather), allowing longer transport distances and reducing emissions and odour in limited urban areas.

## References

- [1] Răcănel Carmen, Burlacu Adrian, Surlea Claudia: Establishing of Wearing Course Asphalt Mixture Stiffness, First International Conference on Road and Rail Infrastructure, CETRA, 17-18 may 2010, Opatija, Croatia, ISBN 978-953-6272-37-2
- [2] Răcănel Carmen, Burlacu Adrian, Surlea Claudia: Laboratory Results Obtained on New Asphalt Mixtures with Polymer Modified Bitumen, 2<sup>nd</sup> International Conference on Transport Infrastructures, ICTI2010, 4-6 August, 2010 Saõ Paulo, Brazil, ISBN 978-972-8692-57-5
- [3] Răcănel Carmen, Burlacu Adrian: Laboratory Tests Concerning Fatigue Behavior of Asphalt Mixtures with Polymer Modified Bitumen for Wearing Course, 4<sup>th</sup> Symposium, Road Research and Administration, CAR 2011, 27-28 October 2011, Bucharest, Romania, ISBN 978-973-100-189-0
- [4] SR EN 12697/26 -2005. Bituminous mixtures – Test methods for hot mix asphalt – Part 26: Stiffness
- [5] SR EN 12697/24 -2005. Bituminous mixtures – Test methods for hot mix asphalt – Part 24: Resistance to fatigue
- [6] SR EN 13108/20 -2005. Bituminous mixtures – Material specifications – Part 20: Type testing



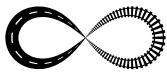

## AIRPORT ASPHALT MIXTURES BEHAVIOUR TO FATIGUE AND PERMANENT DEFORMATION

Claudia Petcu, Carmen Răcănel

*Technical University of Civil Engineering of Bucharest, Romania*

### Abstract

The study of bituminous mixtures behaviour is of very old origins. Taking into account various factors, many scholars in the field tried to explain the degradation causes. In road structures design, fatigue and permanent deformations were always the main factors that had to be taken into account. Fatigue occurs and develops because of the deformation from repeated tensile loads of traffic data which determined tensile stress in the road layer; and permanent deformations occur due to repeated traffic loads superimposed/combined with high temperatures. Both phenomena, fatigue and permanent deformation play an important role in pavement design.

The objective of this research is to estimate the fatigue behaviour and permanent deformations of bituminous mixtures designed for airport, BBA 16 (the design of airport asphalt mix whose recipe was made by both the Marshall and SUPERPAVE method and framed according to the French Norm NF P 98-131, LCPC French Design Manual–2007 and European Norm SR EN 13108-1), framed according to European Standard SR EN 12694-24 as 'Resistance to fatigue', European Standard SR EN 12694-25 as 'Cyclic compression test' and European Standard SR EN 13108-20 as 'Type testing'.

*Keywords: airport asphalt mixture, fatigue, permanent deformation*

### 1 Introduction

The main mechanisms of road structures degradation are the cracking mechanism and the permanent deformation mechanism.

Concerning cracking, there are four types of mechanisms: fatigue cracking due to repeated loading; fatigue cracking due to temperature variations; thermal cracking; cracking due to transmission of substrate cracks.

Fatigue occurs and develops because of repeated tensile strains coming from traffic loads that determine the pavement layer tensile stress. Permanent deformations occur because of repeated traffic loads superimposed to high temperature.

Main mechanisms leading to the appearance of permanent deformations are: permanent deformation structure (profile type 'V'); creep permanent deformation (profile type 'W'); permanent deformations of wear.

The airport pavement and road pavement belong to the same structural family. Both are required to build a platform to resist a given level of traffic and the traffic must be conducted in safe and comfortable conditions. Some aspects due to which the use of flexible structures on airfield area is becoming more and more current are: to have proper adhesion, execution is easier than with the rigid road structures, the structure can be put into exploitation more quickly and it has no joints.



Among the materials the flexible road pavement component or mixed bituminous mixture is considered to be the most important material to be characterized accurately. As is it is well known, the asphalt mixture should be flexible at low temperatures to prevent cracking and rigid enough at high temperatures to prevent rutting. Good asphalt mixture behaviour in exploitation requires a well designed asphalt mixture recipe and a proper compaction in situ.

## 2 Objective

The objective of this research is to estimate the fatigue and permanent deformations behaviour of asphalt mixture designed for airport pavement, namely the BBA 16 and MAMR 16 (the design of mix recipe was made by both the Marshall and SUPERPAVE method and framed according to French Norm NF P 98-131, NF P 98-140, LCPC French Design Manual–2007 and European Norm SR EN 13108-1), framed according to European Standard SR EN 12697-24 as 'Resistance to fatigue' and European Standard SR EN 13108-20 as 'Type testing'.

Laboratory studies were conducted in Roads Laboratory from Faculty of Roads, Railways and Bridges, Technical University of Bucharest.

## 3 Materials

The recipe is designed for asphalt mixtures used in wearing course of the airport pavement (runways, taxiways and platforms); the mixture has 16 mm nominal maximum size. The used filler was a HOLCIM limestone with characteristics shown in Table 1. Aggregates used (8/16, 4/8, 0/4 sort) were from REVĀRSAREA quarry and their characteristics are shown in Table 2. The bitumen was an OMV one, special for airports, with the characteristics shown in Table 3. Having the presented materials two asphalt mixtures were designed with the recipes shown in Table 4.

**Table 1** Filler characteristics

Characteristics	Values
Calcium carbonate content (%)	93.75
Humidity (%)	0.34
Hydrophilic coefficient	0.69
Apparent density after sedimentation in benzene or toluene (g/cm <sup>3</sup> )	0.67
Air voids coefficient in compacted state (%)	0.34

**Table 2** Aggregates characteristics

Characteristics	4/8 sort	8/16 sort	0-4 sort
Apparent density (g/m <sup>3</sup> )	-	2.79-2.86	-
Apparent porosity (%)	-	1.45-1.54	-
Bulk density in loose state (kg/m <sup>3</sup> )	1370-1371	1396-1437	1610
Bulk density in compacted state (kg/m <sup>3</sup> )	1618-1621	1599-1659	1708
Air voids (%)	41	39	-
Los Angeles wear (%)	16-16.2	12-12.6	-
Resistance to frost and taw (%)	-	0.62	-
Resistance to crush – dry (%)	-	92.4-93.2	-
Resistance to crush – saturate (%)	-	90-90.4	-

**Table 3** Bitumen characteristics

Properties	Results
Softening point - Ring and ball (°C)	90
Penetration at 25°C (0.1mm)	48.6
Ductility (cm)	91.5

**Table 4** Asphalt mix recipe

Mix	Source / type	Aggregates			Filer	Bitumen
		8/16	4/8	0/4		
BBA 16	Source / type	Revärsarea			Holcim	45/80 Fr A
	%	29	23	37	11	5.3
MAMR 16	Source / type	Revärsarea			Holcim	45/80 Fr A
	%	35	29	25	11	4.12

## 4 Fatigue

The conducted tests were in accordance with the European norm SR EN 12697-24, and are the following:

- two–point bending test on trapezoidal samples at a 25 Hz frequency and at temperatures of 10°C and 15°C;
- four–point bending test on prismatic samples at two frequencies: 25 Hz and 30 Hz and two temperatures: 15°C and 30°C.

The results obtained from the two–point bending test on trapezoidal samples are presented in Fig. 1.

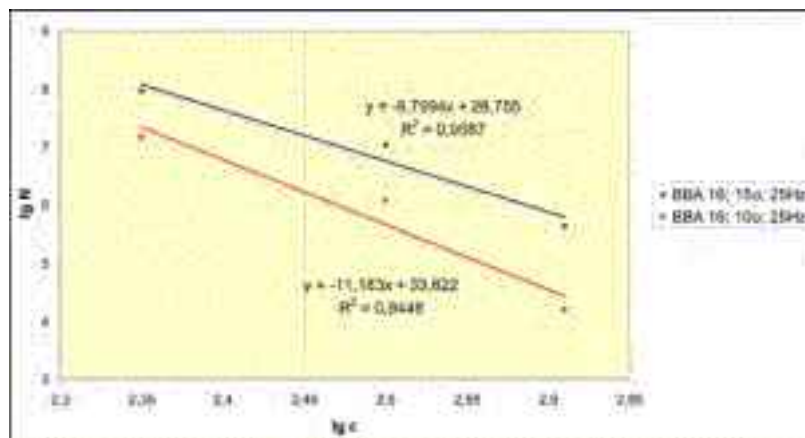
**Figure 1** Fatigue lines of BBA16 asphalt mixtures obtained on trapezoidal samples

The straight lines slope of the two point bending fatigue test was determined from a double–lg scale representations in Fig. 1 and also in accordance with the EN 12697-24, Annex A. The equation is the following:

$$\lg N = a + \left(\frac{1}{b}\right) \cdot \lg(\epsilon) \quad (1)$$

where  $Y = \log(N)$ ,  $X = \log(\epsilon/10.000)$ ,  $N =$  number of charge cycles,  $\epsilon =$  strain.

The values obtained for the slope are presented in Table 5.

**Table 5** Slope values for fatigue lines

Temperature (°C)	Frequency (Hz)	Parameter (1/b)	Equation
10	25	-11.183	Y= -11.183X + 33.622
15	25	-8.80	Y= -8.80X +28.755

The results obtained from the four point bending test on prismatic samples are shown in Fig. 2. The straight lines slope of the four points bending fatigue test was determined from a double–ln scale and it is plotted in Fig. 2 and is also in accordance with EN 12694-24 Annex D equation. The equation is the following:

$$\ln N = A_0 + A_1 \cdot \ln(\epsilon) \quad (2)$$

where Y = lnN), X = lnε/10.000), N = number of charge cycles, ε = strain.  
The values obtained for the slope are presented in Table 6.

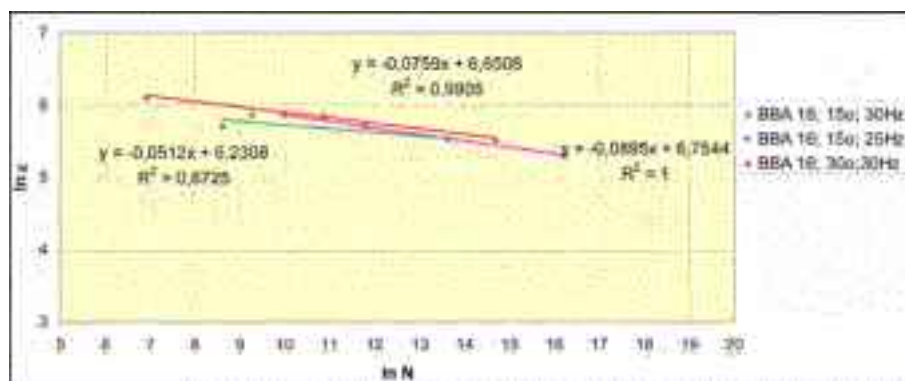

**Figure 2** Fatigue lines of BBA16 asphalt mixtures obtained on prismatic samples

**Table 6** Slope values for fatigue lines

Temperature (°C)	Frequency (Hz)	Parameter (1/b)	Equation
15	30	-0.0512	Y = -0.0512X + 6.2308
15	25	-0.0895	Y = -0.0895X + 6.7544
30	30	-0.0759	Y = -0.0759X + 6.6506

## 5 Permanent deformation

For permanent deformation resistance (creep), on two studied asphalt mixtures, the European norm EN 12697 -25, method B (test temperature 50°C, 300 kPa axial force, pressure 1 bar, 1s/1s frequency) was followed. The results are shown in Fig. 3 and Fig. 4 and Table 7 and 8.

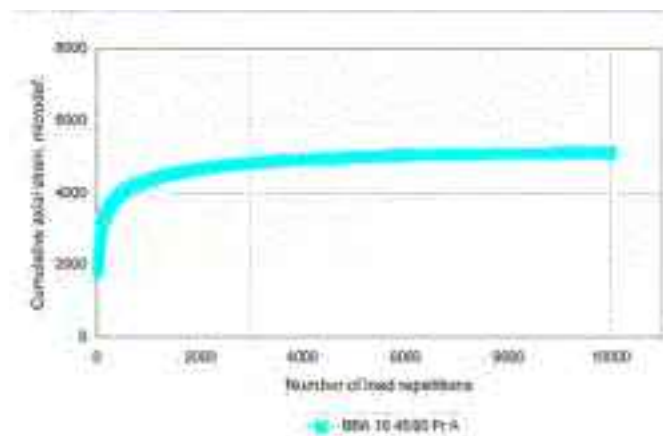

Figure 3 BBA 16 asphalt mixture creep curve

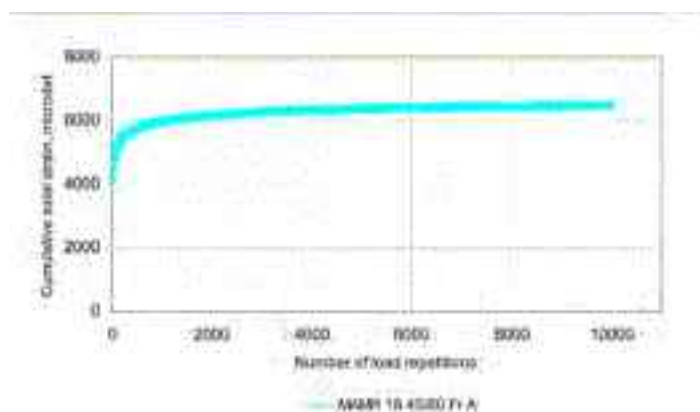

Figure 4 MAMR 16 asphalt mixture creep curve

Table 7 Creep results using method I

Mixture	Equation parameters and stage II Method I ( $\epsilon_n = A_1 + B_1 n$ )		Creep rate $f_c = B_1$	Creep modulus $E_n = \sigma / \epsilon_n$ , kPa		
	$A_1$	$B_1$		initial	1000	10000
BBA 16 45/80 Fr A	4905	0.0213	0.0213	1650	687	587
MAMR16 45/80 Fr A	6260.4	0.0208	0.0208	741	503	464

**Table 8** Creep results using method II

Mixture	Equation parameters and stage II Method II (log $\epsilon_n = \log A + \log Bn$ )		Permanent deformation $\epsilon_{1000}$ : $\epsilon_{1000, calc} = A1000B$	Permanent deformation $\epsilon_{10000}$ : $\epsilon_{10000, calc} = A10000B$
	A	B		
BBA 16 45/80 Fr A	4028	0.026	4821	5118
MAMR16 45/80 Fr A	5188	0.0239	6119	6465

## 6 Conclusions

The conclusions drawn from this study are as follows.

Both in the case of two points bending test on trapezoidal samples (2PB-TR) and in the case of four-point bending test (4PB-PR), the number of cycles decreases with temperature increment, regardless of the imposed strain.

The four-point bending test on prismatic samples shows that with the frequency increment the number of fatigue cycles, at the same temperature, decreases regardless of the imposed strain. For number of cycles at  $10^6$ , a temperature of  $15^\circ\text{C}$  and a frequency of 25 Hz, for four-point bending test on prismatic samples the strain is 260  $\mu\text{def}$  and for two points bending test on trapezoidal samples the strain is 370  $\mu\text{def}$ .

Taking into account the specified conditions that are in accordance with the SR EN 13108-20 for the 4PB-PR test ( $30^\circ\text{C}$ , 30Hz) and the 2PB-TR test ( $10^\circ\text{C}$ , 25Hz) we can observe the following:

- the strain for  $10^6$  cycles,  $\epsilon^6$  is approximately equal in both tests;
- for the 2PB-TR test the  $\epsilon^6$  strain is about 300 mdef and for the 4PB-PR test the  $\epsilon^6$  strain is about 280 mdef.

In comparison with the MAMR16 asphalt mixture, the BBA16 asphalt mixture for airports has a better resistance to permanent deformation. In comparance to the MAMR16 asphalt mixture, there is a significant increase in creep modulus for the BBA16 airport asphalt mixture. Stiffness modulus value depends on the shape of the specimen.

The designed asphalt mixtures have better fatigue behaviour at  $2 \times 10^6$  cycles and could apply a strain much larger than that required by the SR EN 13108-1, SR EN 13108-5 and French Norm NF P 98-131;

The both results received from triaxial compression test are in good agreement with the SR EN 13108-1 and the SR EN 13108-5.

## References

- [1] Brosseaud, Y., Delorme, J.L., Gohie, M., Conan, J. & Letaudun F. :Bétons, Bitumineux Aéronautiques, 2006.
- [2] Buncher, M. & Duval, J.: Superpave for airports.
- [3] Racanel C.: Proiectarea Moderna a Retetei Mixturii Asfaltice, Romania Bucuresti, 2004.
- [4] NF P 98-131: Enrobé hydrocarbonés. Betons bitumineux pour chaussees aeronautiques. Definition. Classification. Caracteristiques. Mise en oeuvre.
- [5] SR EN 13108/1: Bituminous mixtures. Material specifications. Part 1: Asphalt Concrete, 2006.
- [6] French Design Manual LCPC, 2007.
- [7] Standard Special Provision P401-015.

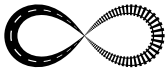

## THE INFLUENCE OF COMPACTION METHODS ON PROPERTIES OF ASPHALT MIXTURES: IMPACT COMPACTION VS. SLAB COMPACTION

Mizan Moges, Carsten Karcher  
*Karlsruhe Institute of Technology, Germany*

### Abstract

The method of laboratory compaction influences the mechanical properties of asphalt specimens. Hence in selecting a compaction method, factors such as the ease, the cost of specimen production and the ability to represent field compaction are considered. Among the different compaction methods, slab compaction is recognized for its considerable similarity to field compaction. On the other hand, the simplicity of preparing specimens using impact compaction method has led to its widespread use despite its failure to simulate field compaction. The goal of the present study was to compare the properties of specimens prepared by impact and slab compaction. The study specifically aims to determine the shift factors that can be used to relate the properties of impact compacted specimens with specimens prepared by slab compaction. The differently compacted specimens were fabricated with identical geometric and volumetric characteristics using two types of mixtures. Properties investigated included the marshall stability and flow, and the resistance to permanent deformation. The permanent deformation behavior of the specimens was evaluated using uniaxial cyclic compression tests. Results showed that the two compaction methods produced specimens with widely varying mechanical properties. Impact compaction was found to produce specimens that were stable and more resistant to permanent deformation than those produced by slab compaction. Specimens produced by impact compaction were also observed to be less susceptible to flow. The comparison of the specimens' properties revealed the shift factors that can be used to accurately translate the properties of impact compacted specimens to those observed in slab compacted specimens. Shift factors are recommended when using impact compacted specimens in performance related testing of asphalt mixtures. The shift factors may enable the impact compaction method to more closely represent field conditions.

*Keywords: asphalt, impact compaction, slab compaction, permanent deformation, compaction shift factor*

### 1 Introduction

The method of compaction is known to influence the mechanical properties of asphalt specimens [1], [2]. Depending on the laboratory compaction method used to simulate the field compaction process, the properties of asphalt specimens have been found to vary [3], [4]. The variation in properties has been largely attributed to the difference in the aggregate matrix produced by the different methods of compaction [5], [6], [7]. Four methods of compaction have commonly been used to produce specimens in the laboratory: Impact, vibratory, gyratory and slab compaction. The methods are summarized as follows.

Impact compaction is the most widely used method of laboratory compaction. In this method, a sample of mixture is compacted in a steel mould by repeatedly dropping a standard

hammer. Impact compaction offers the possibility of fabricating specimens with relative ease and at low-cost [8]. The impact nature of the compaction mechanism however, has been noted to poorly represent the kneading effect that exists in field compaction [3], [9].

In vibratory compaction, a rotating vibratory hammer is applied to the specimen face to achieve compaction. The vibratory hammer has the ability to achieve the target bulk density and air voids contents [5]. However, vibratory compaction results in non-uniformity within the compacted specimen owing to the segregation of the aggregates during compaction [10].

Gyratory compaction involves the application of a constant vertical pressure simultaneously with a kneading type of action. Gyratory compaction is known to produce specimens which are representative of materials compacted in situ [1], [4]. On the other hand, gyratory compacted specimens have been associated with problems of non-homogeneity. Variation in the distribution of air voids and segregation of aggregates in gyratory specimens has been documented [7].

Slab (roller or wheel) compaction applies a compactive force using a curved steel foot, which simulates the rolling pattern of a wheel roller. Slab compaction is recognized for its considerable similarity to field compaction process and produces homogeneous specimens with properties comparable to field cores [11]. In addition, slab compaction enables the rapid fabrication of specimens in required numbers and shapes [8].

The compaction methods are further categorized as mould-based or slab compaction [5]. Impact, vibratory and gyratory compactions are classified as mould based methods due to the fact that the specimens are compacted in cylindrical moulds. In slab compaction on the other hand, specimens are cored and cut from a larger compacted mass [6].

In this paper, the properties of impact (mould-based) and slab compacted specimens were examined. The compaction methods selected represent the most widely used methods of specimen preparation in the laboratory testing of asphalt mixtures. The study aimed at quantifying the influence of the selected compaction methods on the permanent deformation response.

## 2 Experimental Program

### 2.1 Materials

Two types of asphalt mixtures were used in the study. Mixture 1 consisted of 11-mm aggregates bounded with binder 10/40-65A, while mixture 2 comprised of 11-mm aggregates with binder 25/55-55A. The volumetric and mechanical properties of the mixtures are summarized in Table 1.

Table 1 Mixture properties

Property	Mixture 1	Mixture 2
Air voids [%]	4.6	3.6
Binder content [%]	5.8	6.0
VMA [%]	17.5	17.2
VFA [%]	73.7	79.1
Penetration at 25°C [1/10 mm]	16	23
Softening Point [°C]	68.8	65.7
Elastic Recovery [%]	50	70

## 2.2 Specimen preparation

A total of sixteen (16) specimens were used for the study. For each mixture, eight specimens were prepared by impact compaction, while another eight specimens were extracted from roller compacted slabs. The methods of specimen preparations are briefly discussed as follows:

### 2.2.1 Specimen preparation by impact compaction

Impact type compaction was achieved by a mechanical marshall hammer in accordance with DIN EN 12697-30 [12]. In this method, a sample of a mixture was placed in 101.4 mm diameter steel mould, and compacted by 100 hammer–blows. Fifty blows were applied to each face of the specimen.

### 2.2.2 Specimen preparation by slab compaction

A steel compactor was used to prepare specimens according to DIN EN 12697-33 [13]. The slabs were compacted to dimensions of 320 x 260 x 70 mm as illustrated in Figure 1. The thickness of the slab (70mm) was predetermined so that the cored specimens matched the bulk density achieved by impact compaction. Specimens were cored out to dimensions of 100.0 mm diameter.

All specimens were trimmed to a final length of 60mm. The bulk density of the specimens is shown in Table 2.

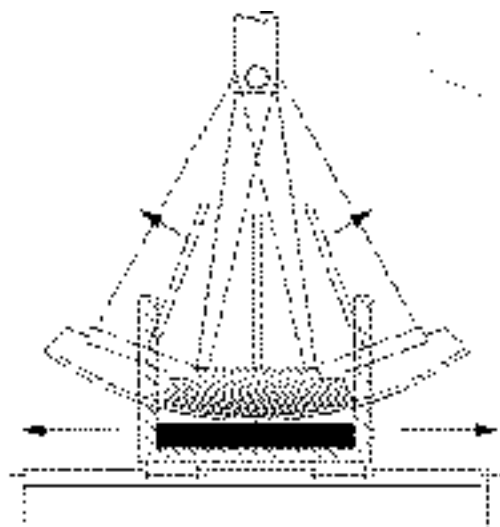

Figure 1 Schematics of slab compaction

Table 2 Bulk specific density of specimens

	Method of compaction	Bulk Density [gm/cm <sup>3</sup> ]	
		Average	Standard Deviation
Mixture 1	Impact compaction	2.320	0.017
	Slab compaction	2.327	0.014
Mixture 2	Impact compaction	2.289	0.006
	Slab compaction	2.295	0.006



## 2.3 Testing methods

### 2.3.1 Marshall stability and flow test

The marshall stability and flow values were evaluated according to DIN EN 12697-34 [14]. For each type of compaction, two specimens were tested. The results of the tests were subsequently averaged to obtain the final stability and flow values.

### 2.3.2 Cyclic compression test

To determine the permanent deformation properties of the mixtures, cyclic compression tests were undertaken. The properties were measured in accordance with the guidelines specified in the German Technical Handbook [15]. The test was carried out with the following test parameters:

- Axial stress: 0.35MPa (maximum) and 0.025MPa (minimum);
  - Load duration: 0.2 seconds (stress pulse duration) and 1.5 sec (rest period);
  - Temperature: 50°C ;
  - Conditioning duration: 2.5 hours;
  - Load cycles: upto 10,000 load repetitions or until a turning point in the course of the strain.
- Three samples each were tested for the specimens prepared by the two methods. In order to minimize the boundary friction effects, the specimen ends were treated with silicon grease and graphite.

The axial strain was measured using three external displacement transducers. For each test, the strain readings were averaged and plotted as a function of the load cycle (Figure 2). The deformation potential of a given mixture was described using the axial strain and the strain rate at the turning point in the course of the strain (see Figure 2).

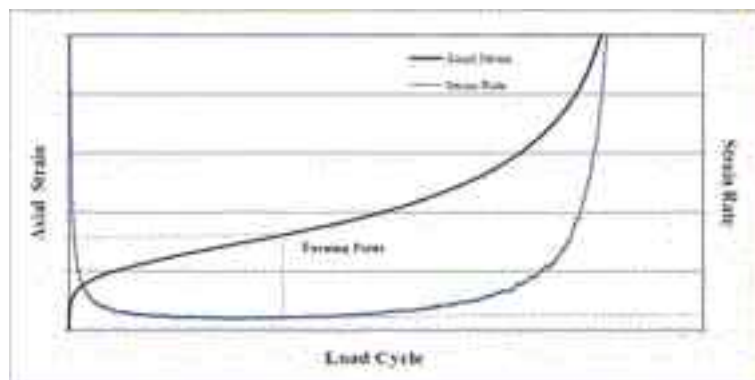

Figure 2 Typical plot of axial strain versus load cycle

## 3 Results

The results of the stability and flow tests are presented in Figure 3 and Figure 4. Figure 5 and Figure 6 summarize the results from the cyclic compression tests.

### 3.1 Influence of compaction methods on stability and flow

The comparison of the marshall stability values in Figure 3 shows that impact compaction gave specimens of slightly higher stability. However, the difference in the stability values between the differently compacted specimens appears to be less marked. Given that the specimens have comparable bulk density, it is reasonable to presume that the influence of

compaction method on stability is insignificant when specimens are compacted to a target bulk density.

Figure 4 on the other hand indicated that the effect of compaction method was more pronounced on the marshall flow of specimens. The flow values of the specimens produced by slab compaction were found to be higher (approximately by a factor of two). Since the volumetric compositions of the specimens are similar, the variations in the flow values might have occurred due to differences in the aggregate structure. The mould confinement in mould based specimens has been noted to induce a greater degree of circumferential aggregate orientation [5]. Accordingly, it is possible that the confining effect that exists in mould based compactions might have created an aggregate structure that is stiffer and less susceptible to flow.

Note: IC= Impact Compaction, SC= Slab Compaction

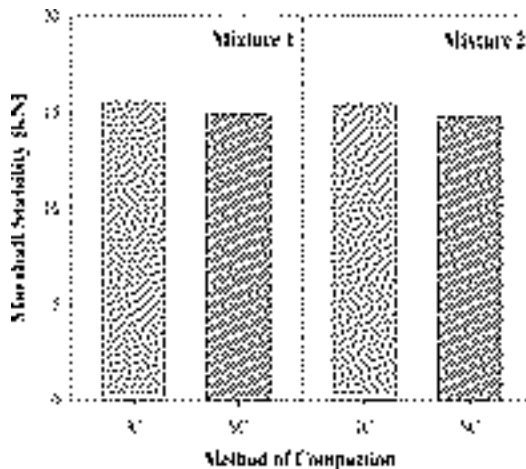

Figure 3 Influence of compaction method on marshall stability

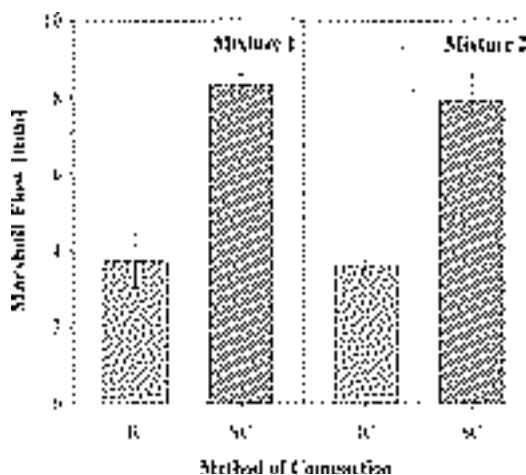

Figure 4 Influence of compaction method on marshall flow

### 3.2 Influence of compaction methods on permanent deformation response

The effect of the compaction method on the resistance to permanent deformation was described using the axial strain (Figure 5) and the strain rate (Figure 6). Note: IC= Impact Compaction, SC= Slab Compaction

From the figures, the following observation was made.

Specimens prepared by impact compaction exhibited lower axial strain in comparison to those prepared by slab compaction. Impact compaction method produced specimens that are approximately three times resistant to permanent deformation than the slab compacted specimens. The low strain observed in impact compacted specimens indicated that mould based specimens were more resistant to permanent deformation.

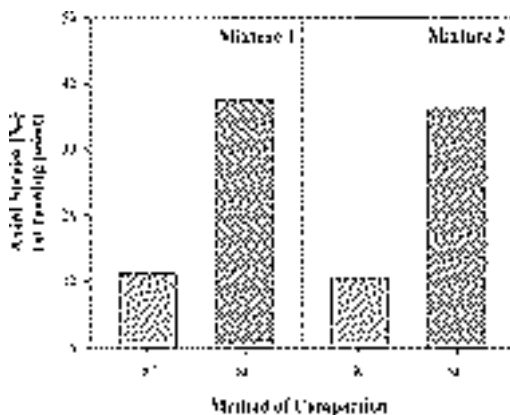

Figure 5 Influence of compaction method on axial strain

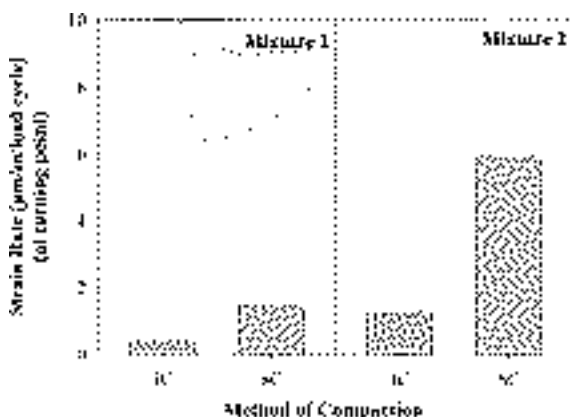

Figure 6 Influence of compaction method on axial strain rate

When using the strain rate as a measure of the deformation performance, it was found that impact compacted specimens displayed a lower rate of deformation. The low deformation rate similarly established that the impact compacted specimens were more resistant to permanent deformation than the specimens produced by slab compaction.

The different performance of the specimens could again be related to the difference in the aggregate matrix. According to Hartman et al. [2], the kneading action generated by slab compaction produced a uniformly distributed aggregate structure that is able to accommodate

the reorientation of the aggregates. Consequently, it can be argued that further compaction of the aggregate particles (in slab compacted specimens) would be expected during the compressive load tests. This is evidently reflected by the excessive deformation observed in slab compacted specimens.

### 3.3 Compaction shift factors

Although it is agreed that slab compaction closely resembles the pavement compaction, the method requires more material to prepare the test specimens. Moreover, the method is labor intensive as specimens have to be cored out from a larger compacted mass. Impact compaction alternatively offers a method for producing specimens with relative ease.

Impact compacted specimens may be used for testing the performance related properties of asphalt mixtures provided that the influences of compaction are factored in. By introducing shift factors, the results of tests using either impact or slab compacted specimens may be used interchangeably. The shift factors account for the variations in the aggregate structure that is unique to the compaction method used.

For the test conditions used in this study, the compaction shift factors for translating the properties of impact compacted specimens with the performance expected in slab compacted specimens are shown in Table 3.

**Table 3** Compaction shift factors

Property	Compaction Shift Factor
Marshall flow [mm]	2.0
Axial strain [‰]	3.3 – 3.4
Axial strain rate [ $\mu\text{m}/\text{m}/\text{load cycle}$ ]	3.9 – 4.0

## 4 Summary

The study demonstrated that the method of compaction affects the mechanical properties of compacted mixtures. The mould based impact compaction method was found to produce specimens that are stiffer and more resistant to permanent deformation than those produced by slab compaction.

Given that impact compaction offers a simplified method for producing specimens, the study recommends shift factors when using impact compacted specimens in performance related testing of asphalt mixtures. The shift factors may enable the impact compaction method to more closely represent field conditions. The shift factors account for the variations in the aggregate structure that is unique to the compaction method used.

## References

- [1] Renken, P.: Influence of specimen preparation onto the mechanical behavior of asphalt mixtures, Proceedings of 2nd Eurasphalt & Eurobitume Congress, Barcelona, pp. 729-735, 2000.
- [2] Hartman, A.M., Gilchrist, M. D. & Walsh, G.: Effect of mixture compaction on indirect tensile stiffness and fatigue, *Journal of the Transportation Engineering*, 127: 5, pp. 370-378, 2001.
- [3] Khan, Z.A., Al-Abdul Wahab, H.I., Asi, I. & Ramadhan, R.: Comparative study of asphalt concrete laboratory compaction methods to simulate field compaction, *Construction and Building Materials*, 12, pp. 373-384, 1998.
- [4] Consuegra, A., Little, D.N., Quintas, H.V. & Burati, J.: Comparative evaluation of laboratory compaction devices based on their ability to produce mixtures with engineering properties similar to those produced in the field, *Transportation Research Record*, 1228, pp. 80-87, 1989.
- [5] Hunter, A.E., Airey, G.D. & Collop, A.C.: Aggregate orientation and segregation in laboratory-compacted asphalt samples. *Journal of the Transportation Research Board*, 1891, pp. 8-15, 2004.
- [6] Harvey, J., Eriksen, K., Sousa, J. & Monismith, C.L.: Effects of laboratory specimen preparation on aggregate-asphalt structure, air-void content measurement, and repetitive simple shear test results, *Journal of the Transportation Research Board*, 1454, pp. 113-122, 1994.
- [7] Masad, E., Muhunthan, B., Shashidhar, N. & Harman, T.: Quantifying laboratory compaction effects on the internal structure of asphalt concrete, *Journal of the Transportation Research Board*, 1681, pp. 179-185, 1999.
- [8] Rao Tangella, S.C.S., Craus, J., Deacon, J.A., & Monismith, C.L.: Fatigue response of asphalt mixtures, Report of Strategic Highway Research Program, National Research Council, Washington, D.C., 1991.
- [9] Jönsson, M., Partl, M. N. & Flisch, A.: Comparison of different compaction methods using x-ray computer tomography, Report No. 113/12, Swiss Federal Laboratories for Materials Testing and Research, Dübendorf, Switzerland, 2002.
- [10] Iwama, M.: Influence of specimen size and orientation on the mechanical properties of laboratory compacted asphalt specimens, Dissertation, The University of Nottingham, 2009.
- [11] Sousa, J.B., Harvey, J., Painter, L., Deacon, J.A. & Monismith, C.L.: Evaluation of laboratory procedures for compacting asphalt-aggregate mixtures, Report of Strategic Highway Research Program, National Research Council, Washington, D.C., 1991.
- [12] DIN EN 12697-30. Test methods for hot mix asphalt — Part 30: Specimen preparation by impact compactor.
- [13] DIN EN 12697-33. Test methods for hot mix asphalt — Part 33: Specimen preparation by slab compactor.
- [14] DIN EN 12697-34. Test methods for hot mix asphalt— Part 34: Marshall Test.
- [15] German Technical Handbook (Technische Prüfvorschriften für Asphalt im Straßenbau (TP A-StB), Teil 25 B 1: Einaxialer Druckschwellversuch- Bestimmung des Verformungsverhaltens von Walzasphalt bei Wärme), Forschungsgesellschaft für Straßen- und Verkehrswesen, 2010.



## BINDER MOBILIZATION IN RAP AND ITS CONTRIBUTION TO MIX PERFORMANCE

X. Carbonneau, F. Lubineau, B. Yvinec, Jean Paul Michaut  
*COLAS DGE, France*

### Abstract

In the road industry, the pressure to shift towards more environmentally-friendly development processes has fostered a growing focus on recycling techniques. This approach is not new, but its novelty lies in the recent trend to maximize the use of reclaimed asphalt pavement (RAP). Furthermore and for a long time mixing plants have been improved to introduce more and more high percentage of RAP. The pressure with sustainable development and the possibility to increase the RAP use have increased the RAP mix design study requirements. With this latter, many questions have been raised such as: what is the right laboratory method? How does the RAP binder influence the performance of the final mix?

This article mainly deals with the last query and gives some answers regarding to the final mix properties. Base course mix design has been chosen and tested with different RAP contents and then has been compared to the traditional base course asphalt concrete. Then asphalt concrete performances have been compared to the binder stiffness modulus, itself taking into account the RAP and the new binder. One of the first finding is that RAP binder mobilization has an influence on the final property of the asphalt concrete performance.

*Keywords: RAP, binder, stiffness modulus*

### 1 Introduction

The use of recycled asphalt pavement (RAP) is not new, but due to environmental pressures and for making savings, it is leading to a considerable rise in its application. The variability of RAP could be a limiting factor when we use it at high percentage in the mix but it's not a problem when the RAP percentage is lower than 20%. Nevertheless, for using at high percentage, a 'uniform' source coming from homogeneous pavements (obtained after milling or crushing or screening) is necessary.

One of the economic interests of this latter is based on an implicit hypothesis that the RAP binder contributes to the performance of the final mix and also reduces the amount of the added pure binder. For clarifying this issue, a study has been conducted to quantify the contribution of the RAP binder to the final mix performances. Before presenting the adopted approach and the results, some of the previously published findings are described.

## 2 The present knowledge

Numerous studies have been lead to demonstrate the blending degree using tracers or by measuring mechanical characteristic as the mix stiffness modulus.

As recycling was developed in the USA, a considerable amount of work has already been performed there, in particular in order to codify practices in the framework of the Superpave mix design method. A technique has thus been proposed for taking account of the characteristics of the binder in RAP and selecting the penetration grade of the added binder on this basis. European standards give the following formulation (for penetration formula 1 or for softening points formula 2) when reclaimed asphalt is used in new formulation for the determination of the final binder in the mix.

$$a \log \text{pen } 1 + b \log \text{pen } 2 = (a + b) \log \text{pen mix} \quad (1)$$

with pen 1 for added pure binder and pen 2 for RAP binder:

$$\text{Trb mix} = a \text{Trb1} + b \text{Trb2} \quad (2)$$

with Trb1 softening point for added pure binder and Trb2 softening point for RAP binder. (a) and (b) are the percentages of each binder and  $a + b = 1$ .

More recently in some European countries, requirements have been made for avoiding the use of RAP in the EME formulation at a high RAP level due to the fact the used RAP binder had the characteristics of soft binder.

## 3 The adopted approach

The mix stiffness moduli seem to be the most easily measured mechanical property in which the contribution of the binder in RAP could be showed. This hypothesis results from the trend that can be observed from Figure 1. The modulus of the mix increases with the modulus of the binder. This graph shows the complex modulus of the mix measured on trapezoidal specimens at 15°C and 10Hz as a function of the binder stiffness measured with a DSR also at 15°C and 10Hz. The abscissa corresponds to the characteristic measured exclusively on the virgin added binder. A number of mixes including RAP, which have not been shown differently, are shown in Figure 1.

The research presented here includes a systematic evaluation, for all the batches, of the mix stiffness from a diametrical compression test (EN 12697-26 with test conditions of 15°C and 124 ms), and a characterization of the virgin added binder, the binder in the RAP and, if applicable, of the perfect blend between the added binder and the binder in the RAP in their respective proportions in the mix. Two complementary approaches were also implemented at the same time.

The first consisted of comparing the modulus values obtained for mixes with identical binder contents and grading curves but different manufacturing processes. A comparison was made between the measured performance of the mix with RAP and an identical mix design which simulates a perfect blend of the two binders (that in the RAP and the virgin added binder, as shown in Figure 2).

The second approach consisted of comparing the modulus obtained on a mix design (with different types of binder) and those obtained with the same mix design (same blended aggregate skeleton) but by adding 30% of RAP. The added binder content was modified in order to maintain the same richness modulus as the reference mix.

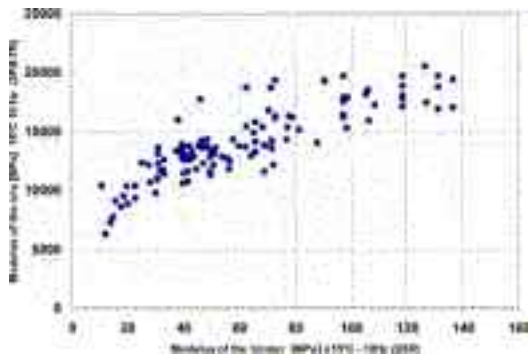

Figure 1 Modulus of the mix versus the measured modulus of the virgin coating binder



Figure 2 Adopted procedure for simulating a perfect blend of the virgin added binder and the binder in the RAP

### 3.1 Characteristics of the used study constituents

In order to quantify how the binder in the RAP contributes to the performance, a known mix, 0/14 High Modulus Asphalt Concrete (EME) made with silica-calcareous alluvial aggregate from the Rhine River has been adopted.

The RAP used for this study was taken from a stockpile mixing plant. The binder content and the measured characteristics of this binder extracted after drying in a thin layer (approximately 5cm) in an enclosure for 12 hours at 50°C are in Table 1. Based on the three types of constituents described above (aggregate, recycled asphalt pavement and pure coating asphalt), several groups of mixes were manufactured in a laboratory as described in Table 2. All the available pure binder classes were used to cover the largest possible range of binder stiffness modulus values. The measured binder characteristics are in Table 3.

The measured characteristics of the binder extracted from the RAP are closer to those of a hard binder, quite similar to those for 10/20 asphalt.

Table 1 Characteristics of the extracted RAP binder

Binder characteristics	
Binder content	4.2 %
Penetration (1/10 mm)	12
TR&B (°C)	69
G* 15°C 10Hz (MPa)	83



**Table 2** Manufacturing conditions applied in the study

Group of mix	Composition	Analysis performed
A	Aggregate: 0/14 Alluvial RAP: 30% Added asphalt: 50/70 pen	Manufacturing methods Hot with conditioning of RAP, warm, and simulating a perfect blend of the mixing binder and the binder extracted from a RAP
B	Aggregate: 0/14 Alluvial Added asphalt: 160/220, 70/100, 50/70, 35/50, 20/30 and 10/20	Reference value of variation of E* against G*
C	Aggregate: 0/14 Alluvial RAP: 30 % Added asphalt: 160/220, 70/100, 50/70, 35/50 20/30 and 10/20	Effect of the modulus of the added binder (G*) on the modulus of the mix
D	Aggregate: 0/14 Alluvial RAP: 20, 30 and 40% Added asphalt: 50/70	Effect of proportion of RAP

**Table 3** Characteristics of the used grade bitumen (1) and (2) identify the two batches of 50/70 pen asphalt used in this part of the study

Grade of pure binder	Pene at 25°C (1/10 mm)	T R&B (°C)	G* 15°C 10 Hz (MPa)
10/20	12	68	98
20/30	20	62	66
35/50	35	54	37
50/70 <sup>(1)</sup>	49	49	43
50/70 <sup>(2)</sup>	58	50	20
70/100	81	46	16
160/220	175	40	8

### 3.2 Manufacturing conditions

The RAP was beforehand dried and then conditioned at 110°C for 2h30 +/- 30 min before the mixes were manufactured. The coating binders were at their normal temperature of use. The temperatures are shown in Table 4.

**Table 4** Chart for selecting the temperature to which the new aggregate should be heated according to dry RAP percentage

Recommended temperature for mix	RAP content (%)		
	20	30	40
120	125	125	130
140	150	155	160
160	175	180	190
180	200	210	230

### 3.3 Results

The results obtained for the mixes in group A (see Table 2) are presented in Figure 3. The mix stiffness made with 50/70 pen asphalt and 30% of RAP is not significantly different from the control mix. This result does not seem to indicate that the binder in the RAP makes an obvious contribution to performance. However, the measured value is also close to what is obtained with a batch that simulates a perfect blend.

The figure 4 shows the Group B values. The asphalt concrete manufactured without RAP, using all the pure bitumen shows there is a direct link between the measured asphalt concrete stiffness modulus and the one determined on the coating bitumen. The asphalt concrete stiffness variation when all the other characteristics are kept constant (nature of the materials, binder content, voids content) is directly linked to the binder stiffness modulus variation. The modulus values obtained for the mixes in groups B and C are indicated in Table 5.

**Table 5** Measured stiffness for Group B and C (The geometric void content averages are given in brackets)

Class of coating binder	Modulus of formulae without RAP [B]	Modulus of Formulae with 30% RAP [C]
10/20	19251 (4.9)	16303 (5.5)
20/30	11833 (5.2)	11318 (5.7)
35/50	7688 (5.2)	7876 (5.2)
50/70 <sup>(1)</sup>	8222 (5.1)	8051 (5.8)
50/70 <sup>(2)</sup>	3344 (5.3)	5255 (5.2)
70/100	3578 (5.5)	5463 (3.8)
160/220	1945 (5.7)	3536 (5.8)

In the case of the blends manufactured with the softest binders, we can observe that those which include RAP have a higher modulus than those with only alluvial aggregate, while the opposite applies to the blends made with the hardest binders.

We can also present the analysis of the data by plotting the mix modulus versus binder modulus. This raises the question of what value to adopt for the modulus of the binder. The possible extremes are known as they correspond either to the hypothesis that no blending will occur, in which case the abscissa consists of the modulus of the added binder, or a perfect blend. In the second case, the modulus is estimated on the basis of the proportions of coating binder and binder from RAP in the mixture and their respective moduli by applying the following equation:

$$\text{LogG}^*_{(\text{perfect blend of binders})} = a \text{LogG}^*_{\text{virgin asphalt}} + b \text{LogG}^*_{\text{Asphalt from RAP}} \quad (3)$$

a and b being respectively the proportions of binder extracted from RAP and virgin asphalt in the binder in the mixture, a + b=1.

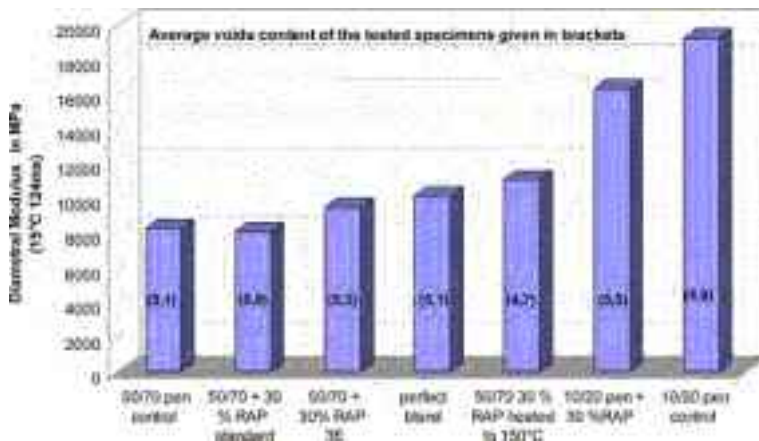

Figure 3 Modulus values measured on the different batches of group A

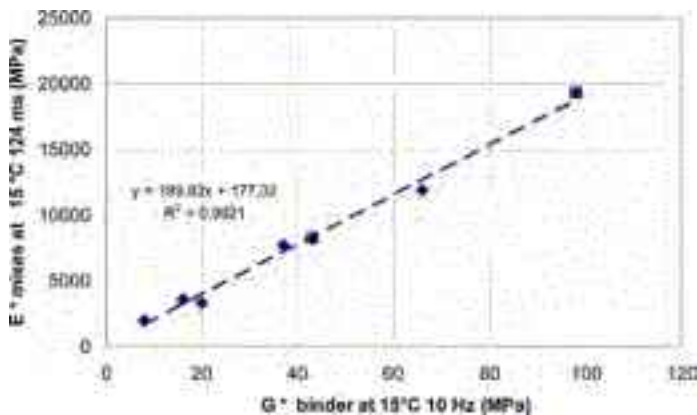
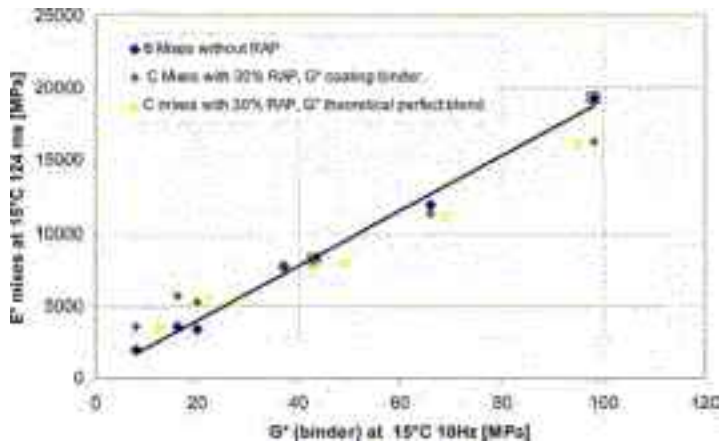

Figure 4 Measured mix stiffness and binder stiffness for constant grading curve and density

We have plotted these two extreme hypotheses on Figure 5, which also states the values obtained for the Group b.

When the  $G^*$  value of the binder calculated in the case of a perfect blend is placed on the abscissa, there is an increase in the value on the abscissa for the formulae with the softest binder and a reduction in the case of the formula with 10/20 pen asphalt, which is the only binder with a higher modulus than that determined for the binder extracted from the RAP (see Tables 1 and 3). In the case of binders with lowest modulus values, the points which correspond to a perfect blend are close to the control line for the case without RAP.

In the case of Group D, manufactured with a 50/70<sup>(1)</sup> pen asphalt ( $G^*$  value of 43 MPa), for the 3 percentages of RAP (20, 30 and 40%), stiffness are presented in Table 6.



**Figure 5** Mix modulus measured on the formulae with 30% of RAP versus the binder stiffness, with the value for the coating binder or that calculated for a perfect blend

**Table 6** Measured modulus values for the group D

Formulation	with 20% RAP		with 30% RAP		with 40% RAP	
Test temperature (°C)	10	15	10	15	10	15
% of voids	5,9		5,8		5,4	
Modulus 15°C 124ms [MPa]	14322	10332	13682	8051	16655	10560

There is not a large increase in the modulus value as the proportion of RAP increases. The formula with 30% of RAP even has a slightly lower modulus than the blend with 20% of RAP. However, in the case of these three mixes, RAP provides respectively 13.3, 19.7 and 26.3% of all the binder. From this data, the theoretical value of the modulus in the case of a perfect blend for these three mixtures can be calculated and are respectively the followings: 46.9, 48.9 and 51.1 MPa. If the effect of the minor variation in the granular skeleton is not taken into account for the mix modulus, the variation of the theoretical  $G^*$  increase should correspond of around 380 MPa between 20 and 30% of RAP and below 800 MPa between 20 and 40%. These effects are almost lower than the reproducibility of the test. They may therefore explain the difficulty in measuring a difference between two mixes which only differ in terms of the proportion of RAP.

## 4 Conclusions

However, considerable amount of work must be done in order to promote and develop recycling by demonstrating that the technique has been fully mastered and that performances are guaranteed. This study did not consider fatigue strength. This is fundamental for the materials used in sub-base and road base layers in which the RAP proportions could be maximized. However, we do not have now an indicator based solely on the intrinsic characteristics of the RAP binder which gives us a reliable idea of how it will affect the fatigue strength of the mix. The necessary research in the framework had not be performed in this study, in spite of the large number of findings that are available within the Colas Group. For example, EME containing RAP are shown in Figure 6 and present no apparent specific risk.

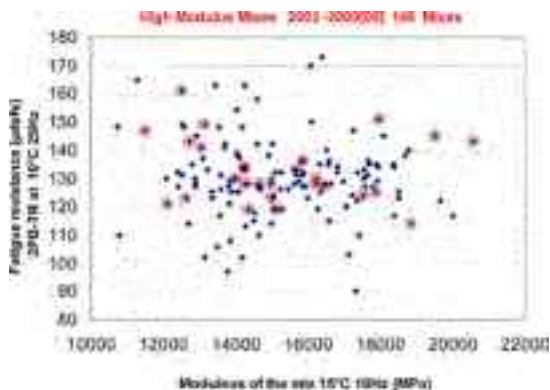

Figure 6 Modulus and fatigue performances of EME with (in red) and without RAP

Although the contribution of the binder extracted from RAP has been established, its impact on performance can only be demonstrated in special cases, when there is a high proportion of binder extracted from RAP in the mixture and a large disparity between the modulus of the added binder and that of the binders extracted from RAP. It is not possible to specify a recycling rate that permits the use of a new binder of a 'lower' class than that normally used for the mixture without RAP. This is because the proportion of the binder extracted from RAP will dominate at a lower recycling rate for road base asphalt than for products such as EME. This research did not focus on warm mixes either. Environmental issues and the need to save energy mean that we must develop these techniques. What impact can a lower manufacturing temperature have on the effective contribution of the binder extracted from RAP? To answer to this question more results are necessary.

Overall, the results presented here show the contribution of the binder extracted from RAP to the performance of the mix under our selected laboratory conditions. It substantiates the common hypotheses and practices which consider the binder extracted from RAP as an integral part of the bituminous binder in the mixture. The optimization of mixtures with high recycling rates is still a topic for research, which is made more difficult by the need to take account of new parameters such as the modulus values of the added binder and the binder extracted from RAP. The Colas Group is already engaged in the necessary work of supplementing this theoretical approach by monitoring a large number of worksites. This will provide an opportunity to obtain new concrete technical information in order to develop the recycling.



## PERMANENT DEFORMATION OF POLYMER MODIFIED BITUMEN

Vesna Ocelić Bulatović<sup>1</sup>, Vesna Rek<sup>1</sup>, Kristina Jurkaš Marković<sup>2</sup>

<sup>1</sup> University of Zagreb, Faculty of Chemical Engineering and Technology, Croatia

<sup>2</sup> IGH d.d, Croatia

### Abstract

Bitumen (BIT) has been used in most road applications for many decades as the binder for asphalt. The most common distresses directly associated with the binder phase in road are a permanent deformation known as rutting and thermal cracking. This has resulted in the need to improve the properties of existing bitumen. In order to produce BIT with improved properties, polymers are used. It is known that the modified binders vary significantly in their sensitivity to traffic speed, to traffic volume, and to stress or strain level that varies according to the pavement structure, which has indicated the importance of investigations into rheological properties. The investigation into rheological properties of polymer modified bitumens (PmBs), with various polymers as potential modifiers, as well as of bitumens, makes it possible to characterize and evaluate PmBs as binders.

The Strategic Highway Research Program (SHRP), a research program in the field of road construction, includes the investigation into rheological properties at a traffic frequency and a temperature, which gives an insight into a permanent deformation known as rutting and into the effect of thermo-oxidative ageing.

In this paper, the following polymers are used as bitumen modifiers: styrenebutadiene–styrene block copolymers, linear and radial structure (SBS–L, SBS–R), plastomer ethylene–vinyl acetate (EVA) and reactive polymer ethylene butylacrylate glycidylmethacrylate (Elvaloy AM). Resistance to permanent deformation includes investigations into rheological properties of BIT and PmB performed by a dynamic shear rheometer (DSR) in a broad temperature range at a traffic frequency before and after ageing. The ageing of the investigated materials and their thermo-oxidative stability are determined by the Rolling Thin Film Oven Test (RTFOT).

Polymer modified bitumens are less sensitive to temperature and traffic speed than bitumen. They have a higher critical temperature, i.e. better resistance to permanent deformation. The critical temperature depends on the polymer type and content.

*Keywords: PmB, DSR, rheological properties, permanent deformation, SHRP*

### 1 Introduction

Natural bitumen (BIT) started to go out of use in road construction in the 1910s [1]. The highest percentages of bitumens that are produced worldwide each year are applied in the paving industry where they essentially act as binders for mineral aggregates to form asphalt mixes. In order to make sure that the mixture resists the climate and traffic, specifications of bitumen have become quite strict. The properties that are needed to obtain suitable bitumen are mostly rheological. Bitumen has to be fluid enough at high temperature to be pumpable and workable [2, 3]. Further, it has to be stiff enough at the highest pavement temperature to resist rutting and it must remain soft enough at the lowest pavement temperatures to resist

cracking. All these properties are of conflicting nature and it is therefore difficult to obtain bitumen that would work under all possible climates. The current traffic loads and volume of vehicles considerably reduce the lifetime of pavements. In order to get longer periods between repairs and to reduce the total cost of road pavements new bituminous materials have to be developed. This has contributed to a large increase in the use of polymers as bitumen modifiers [2]. Two types of polymers are typically used in bitumen modifications, i.e. non-reactive plastomers and elastomers and reactive polymers. Non reactive plastomers and elastomers form a physical network between the bitumen and a polymer. The polymer is swollen by light aromatic components from the bitumen, i.e. by maltenes. Consequently, the polymer rich phase occupies between 4 to 10 times higher volume than that of the added polymer [4, 5]. This formation increases the complex modulus. It is an indication of resistance to rutting and a contribution to good elastic properties of the modified bitumen [4, 6]. Reactive polymers containing functional groups are able to form chemical bonds with certain bitumen compounds, thus improving the mechanical behaviour, rigidity, storage stability and temperature susceptibility of the bitumen [1,2, 7–9].

Generally, polymer modified bitumens (PmBs) are considered to have a longer life or higher pavement performance than bitumens [3, 10]. Polymers increase the resistance of the bitumen to traffic loading by reducing the permanent deformation at high temperature and thermal cracking at low temperature. They also prevent the phase separation and improve storage stability [2]. Characterization of bitumen and polymer modified bitumen as good binders for pavements should be based on rheological properties [1]. The properties of bitumen–polymer blends depend on the concentration and the type of polymer used.

In Europe, the characterization of bitumen and PmBs is still limited to conventional tests such as penetration and ring and ball softening temperature. The US characterization adopted the Strategic Highway Research Program (SHRP) which is based on rheological behaviour. Within the SHRP, the permanent deformation of BIT and PmB is correlated to viscoelastic functions, the shear complex modulus  $G^*$  and the phase angle  $\delta$  by means of the equation  $G^*/\sin\delta$  [1, 11–12]. Thus, bitumens with a high complex modulus and a high degree of elasticity produced pavements with a low tendency for permanent deformation. The most commonly used method of rheological testing of BIT and PmB, which was included in the SHRP, is a dynamic mechanical method using the oscillatory type testing with dynamic shear rheometers, DSRs [2–4, 6]. The aim of this research is to compare the modification ability of two different types of bitumen modifiers, i.e. non-reactive plastomers and elastomers and reactive polymers, with respect to the rheological properties of PmBs. The testing was carried out in a set range of temperatures under defined traffic frequencies using a DSR. The group of non-reactive polymers included a thermoplastic block copolymer (SBS) with two different structures, a linear and a branched one, and the plastomer ethylene–vinyl acetate random copolymers (EVA). In the second group, reactive polymers included a thermopolymer ethylene butylacrylate glycidylmethacrylate (GMA), commercial name Elvaloy. Due to their composition, they are often called reactive ethylene thermopolymers (RET). These types of polymers have proved themselves as good modifiers which reduce permanent deformation and thermal cracking. This paper presents the characterization of the properties of PmBs modified with the above mentioned polymers, carried out by using conventional and empirical test methods as well as rheological measurements with reference to the SHRP to prove the permanent deformation.

Bitumen ageing during production, application and service life is one of the principal factors causing the deterioration of asphalt pavements. [10]. Ageing is a very complex process in BIT and even more complex when polymer bitumens are involved. Oxidation and physical hardening are present in BIT ageing [5]. The factors affecting the ageing of BIT and PmB include characteristics of BIT, the composition of BIT and PmB, the polymer content, and structure and phase interactions [13].

The rheological properties of unaged PmBs and of PmBs after artificial thermo-oxidative ageing were determined by the Rolling Thin Film Oven Test (RTFOT).

## 2 Experiment

### 2.1 Materials

The investigations were conducted with:

- BIT 70/100, INA Refinery Croatia, Rijeka.

The polymers used as modifiers were:

- 1 Thermoplastic styrene–butadiene–styrene block copolymers
  - SBS-L – linear with a content of polystyrene of 31 wt%, commercial grade Kraton D 1101
  - SBS-R – radial, with a content of polystyrene of 30 wt%, commercial grade Kraton D 1184, manufactured by Shell Chemicals Company, Germany.
- 2 Plastomer semi–crystalline copolymer ethylene–vinyl acetate
  - EVA – containing 28 wt % vinyl acetate, commercial grade Elvax 265
- 3 Thermopolymer ethylene – butylacrylate – glycidylmethacrylate
  - Elvaloy AM – containing butylacrylate 28 wt%, glycidylmethacrylate 5.3 wt%, manufactured by DuPont, USA.

### 2.2 Sample preparation

All PmBs were prepared by using a Silverson L4R mixer. First, the base bitumen was adequately heated (160°C) and stirred for about 2h to obtain homogeneity and was then poured into 1 L aluminium cans. The cans of bitumen were then heated to 180–185°C and stirred for 10 min before adding a polymer. The polymer content was 2 wt%, with the exception of Elvaloy AM where the content was 1.9% because of gel formation at higher polymer content. Polymers were then added slowly into the bitumen, under high speed stirring for 4h until the blend became thoroughly homogenous. A constant temperature was kept while the mixing process continued. For the preparation of PmB modified with Elvaloy AM, the softening point was checked after 1h of stirring to make sure that the reaction between the polymer and bitumen had started. When the reaction started, the cans were transferred to an oven and were kept at 180°C for 24 h under static conditions and in an oxygen–free environment to ensure a complete reaction.

After completion, the blends were removed from the aluminium cans and divided into small containers covered with aluminium foil and stored for testing at ambient temperature.

## 3 Measurements

### 3.1 Conventional tests

The base bitumen and PmBs were subjected to the following conventional bitumen tests according to standards: penetration test (HRN EN 1426), ring and ball technique to determine the softening point temperature (HRN EN 1427), elastic recovery test (HRN EN 13398) and the Frass breaking point test (HRN EN 12593/01). The storage stability of PMBs was determined according to standards HRN EN 13399. The results of these tests are listed in Table 2.

### 3.2 Rheological measurements

Rheological measurements to determine viscoelastic parameters such as complex modulus  $G^*$ , complex viscosity  $n^*$ , and phase angle  $\delta$  were performed using a dynamic shear rheometer, DSR, MCR 301, Anton Paar with the Peltier temperature control system. The dynamic rheometer is a type of testing equipment applying oscillatory loading on a material sample. The DSR tests were performed under controlled strain loading conditions using temperature sweep tests. A temperature sweep was applied over the range of -5°C to 80 °C at a fixed traffic



frequency of 10 rad/s (cca 85 km/h) and variable strain. Preliminary tests were carried out at different temperatures in order to determine the strain range within which the bitumen remains in the linear viscoelastic range (LVN) [14]. The temperature sweep tests for low temperatures between -5°C and 30°C were carried out with a parallel plate testing geometry of 8 mm diameter and 2 mm gap, and for medium and higher temperatures the tests were done with a parallel plate testing geometry of 25 mm diameter and 1 mm gap. To provide a more profound insight into rheological properties, the critical temperature without permanent deformation (rutting) was determined according to the SHRP [1, 12]. The critical temperature is both the temperature at which  $G^*/\sin\delta$  is equal to or less than 1 kPa at a frequency of 10 rad/s (strain is constant 10%) before ageing and that at which  $G^*/\sin\delta$  is equal to or less than 2.2 kPa (strain value 12 %) after ageing. The critical temperature was determined automatically by the DSR software.

### 3.3 Ageing procedure

Accelerated thermo-oxidative ageing of base bitumen and PmBs was performed using the Rolling Thin Film Oven Test, RTFOT, according to ASTM D 2872. The RTFOT procedure simulated the short-term ageing of bitumen and PmBs. The bitumen and PmBs were exposed to elevated temperatures to simulate the conditions during the production, mixing and laying of asphalt mixes. Samples of a specific weight were placed into glass containers heated to 163°C for about 15 min and then they were placed into a rotating oven heated at 163°C for 85 min with the air on and with a flow rate of 4 L/min. All measurements were done before and after the simulated ageing in the laboratory, i.e. before and after the RTFO test.

## 4 Results and Discussion

Figs 1–6 show the results of rheological measurements of the base bitumen, BIT, and the polymer-modified bitumens, PmBs, modified with the styrene-butadiene-styrene (SBS) block copolymers, with a linear and a radial structure (SBS-L, SBS-R), the semi-crystalline copolymer ethylene-vinyl acetate (EVA) and reactive polymer ethylene butylacrylate glycidylmethacrylate (Elvaloy AM) in dependence on temperature. Changes in  $G^*$ ,  $n^*$  and  $\delta$  in the temperature range of -5°C to 80°C under the fixed traffic frequency of 10 rad/s are noted (Figs 1–3). The  $G^*$  values of the base BIT and PmBs decrease as the temperature increases (Fig. 1). The  $G^*$  and  $n^*$  values of PmBs are higher than the same values of the base BIT (Figs 1 and 2). The PmB modified with the plastomer EVA and SBS-L shows higher values of  $G^*$  and  $n^*$  compared with other modifiers. It means that a polymer gives stiffness to the bitumen, particularly EVA and SBS-L. The modification with a reactive polymer and SBS-R shows significant changes at higher temperatures of above 50°C. The formation of elastic plateau is noted on the  $G^*/T$  and  $n^*/T$  curves of PmBs modified with Elvaloy AM and SBS-R (Figs 1 and 2). It indicates the formation of a physically cross-linked network in the BIT modified with SBS-R and also the reaction of epoxy group and the formation of chemical network in BIT modified with Elvaloy AM [7]. Comparison results on the  $G^*/T$  and  $n^*/T$  curves for SBS-L and SBS-R indicated that SBS-R shows an elastic plateau due to better various interactions between SBS-R and BIT. These interactions are more pronounced with a higher content of SBS-R in BIT, which was proved in the previous paper [6]. In Elvaloy AM, the elastic plateau is formed due to the formation of chemical bonds with bitumen. At lower temperatures in a range of -5°C to 15°C the PmB modified with EVA and SBS-R has the same values of  $G^*$  and  $n^*$  as the pure bitumen, while Elvaloy AM shows lower values and SBS-L higher values compared with BIT (Figs 1 and 2). The BIT modified with SBS-L has greater stiffness at low temperature areas than the BIT modified with Elvaloy AM, which indicates enhanced resistance to low temperature cracking [7]. The changes in the phase angle  $\delta$  related to the changes in temperature (Fig. 3) are more expressed than the changes in  $G^*$  in the same temperature range (Fig. 1). The phase angle

is more sensitive to the chemical structure and its change is more expressed in PmBs than the changes in  $G^*$  and  $n^*$  (Figs 1 and 2) [15]. The base bitumen shows predominantly viscous behaviour with an increasing temperature, as can be seen at a fixed frequency and at temperatures exceeding some 50°C, and the phase angle of the base bitumen approaches 90° (Fig. 3). In this case the stored energy per cycle of deformation becomes negligible compared to that dissipated as heat [7]. The  $\delta/T$  curves of PmBs are shifted to lower  $\delta$  values (Fig. 3). Lower  $\delta$  means that polymers significantly improve the elasticity of the modified bitumen. This higher elastic behaviour could indicate that PmBs have lower susceptibility to permanent deformation/ rutting [16]. At low temperatures (<10°C), there is no significant difference in the phase angle of pure bitumen and PmBs, except SBS-L. At intermediate temperatures (15°C – 60°C), one can note large differences in  $d/T$  of PmBs. EVA shows the lowest value of phase angle which rapidly increases with increased temperature, thus indicating the dominance of viscous behaviour. For SBS-L and SBS-R, the plateau formation is noted. It is related to the formation of polymer network as a consequence of SBS swelling in the maltene phase in BIT. For the Elvaloy AM, the values on the  $\delta/T$  curves increase with temperature, and at 30°C reach an approximately constant value. This is related to the already mentioned formation of chemical bond, resulting in better behaviour at higher temperatures. This difference may be assigned to a different level of compatibility of a polymer with bitumen.

The changes in rheological properties, i.e. in  $G^*$  and  $n^*$ , and in  $d$  are noted after ageing under the RTFOT conditions (Figs 4–6). After ageing, the  $G^*$  and  $n^*$  values of BIT are higher. This is related to the higher stiffness, which is a consequence of the oxidation process of BIT. Also, PmBs with EVA, SBS-L and SBS-R show a larger increase in  $G^*$  after ageing (Fig. 4), which means that besides the oxidation process, degradation reactions as well as secondary processes of crosslinking are included. As for Elvaloy AM, no large increase in the values of  $G^*$  and  $n^*$  can be noted after ageing (Figs 4 and 5). This is associated with the resulting chemical bond which contributes to the retention of the properties and good stability.

After ageing, the  $\delta$  values of BIT on the  $\delta/T$  curve are evidently lower as well as the  $\delta$  values of PmBs (Fig. 6).

The ageing effect is strongly temperature-dependent. At medium and high temperatures the aged samples are characterized by higher stiffness and elasticity, whereas at low temperatures, the rheological properties  $G^*$  and  $\delta$  are not affected by ageing.

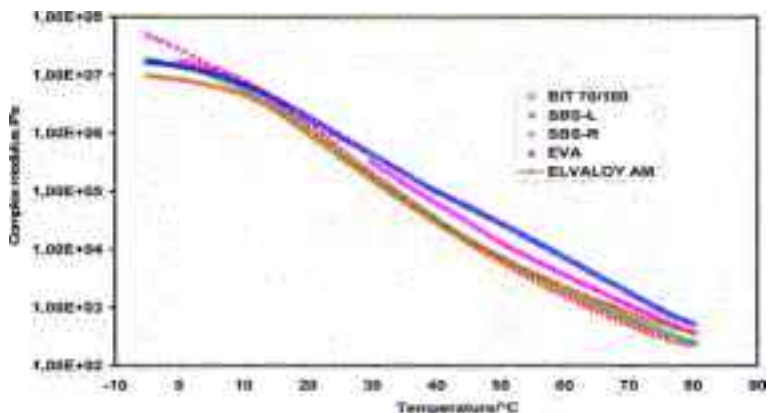

Figure 1 Complex modulus as a function of temperature for BIT 70/100 and PmBs

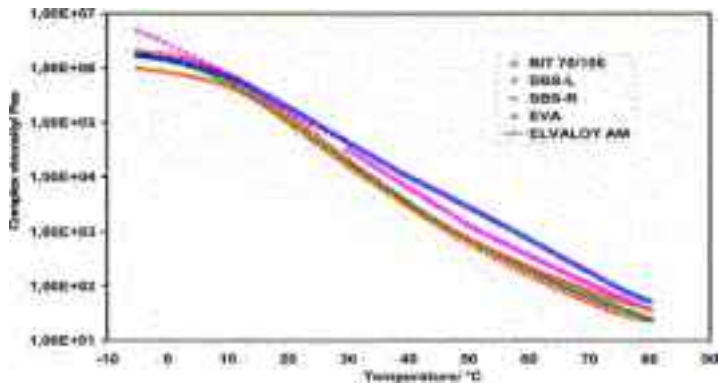

Figure 2 Complex viscosity as a function of temperature for BIT 70/100 and PmBs

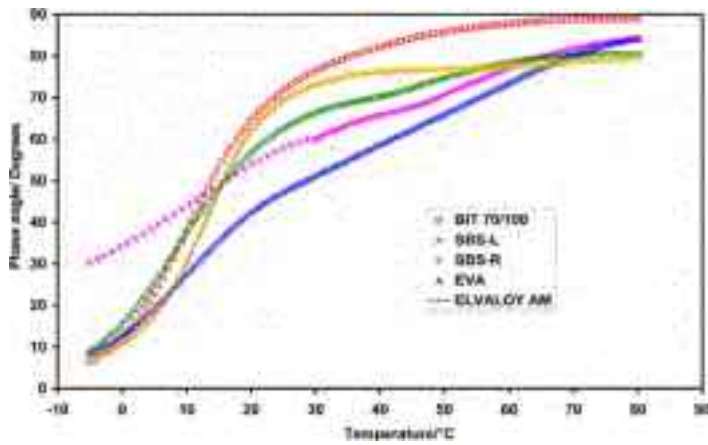

Figure 3 Phase angle as a function of temperature for BIT 70/100 and PmBs

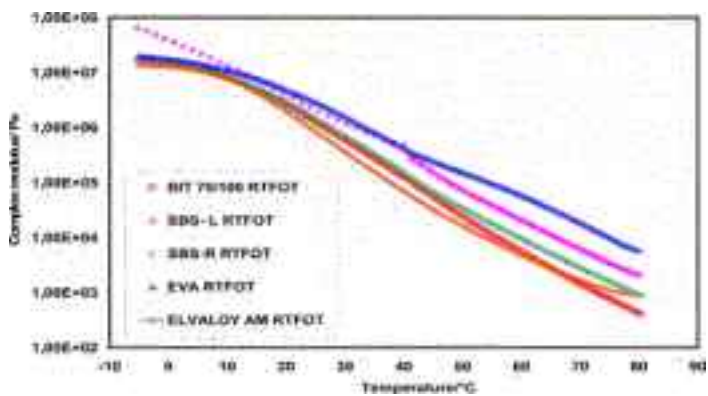

Figure 4 Complex modulus as a function of temperature for BIT 70/100 and PmBs after RTFO

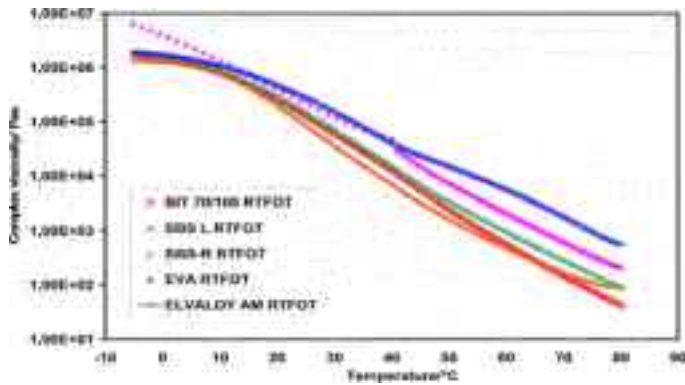

Figure 5 Complex viscosity as a function of temperature for BIT 70/100 and PmBs after RTFOT

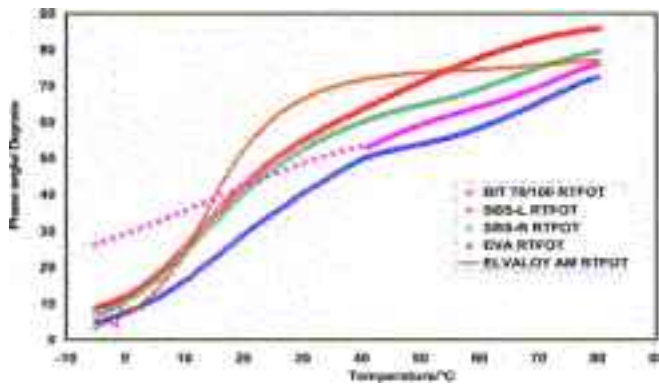

Figure 6 Phase angle as a function of temperature for BIT 70/100 and PmBs after RTFOT

The critical SHRP temperature values for permanent deformation, when the value of  $G^*/\sin\delta \geq 1$  kPa before ageing, and the value of  $G^*/\sin\delta \geq 2.2$  kPa after ageing, are presented in Table 1. The critical temperatures of PmBs are higher than that of the base bitumen. The BIT modified with EVA exhibits the highest value of critical temperature for permanent deformation, i.e. rutting, but it also exhibits a great difference in critical temperatures before and after ageing. Comparing the obtained results it is evident that SBS-R and Elvaloy AM show the same values of critical temperature for rutting, i.e. 70°C. The same temperature was determined after ageing. The higher critical temperature of BIT/SBS-R is related to a better interaction between the polymer and bitumen, resulting in a physical network. On the other hand, the higher critical temperature in BIT/Elvaloy AM is a result of a chemical bond between BIT and the polymer.

Table 1 The critical SHRP temperature for permanent deformation

Sample	Before RTFOT		After RTFOT	
	T/°C	( $G^*/\sin\delta$ )/kPa	T/°C	( $G^*/\sin\delta$ )/kPa
BIT 70/100	64	1.44	64	3.60
SBS-L	64	1.70	70	4.35
SBS-R	70	1.74	70	3.83
EVA	76	1.73	88	2.44
Elvaloy AM	70	1.26	70	3.68

Better rheological properties of PmBs and better resistance to temperature can be also noted in conventional tests (Table 2). For better understanding, Figures 7 and 8 show graphically the results of the softening point (R&B), penetration, and elastic recovery tests carried out on PmBs with a content of 2% added polymers, and on bitumen. To improve the PmB performance, a polymer should be able to increase the softening point value and the elastic behaviour of the bitumen without decreasing the penetration range too much [17]. The best compromise between these parameters is reached by the PmBs modified with SBS-R and Elvaloy AM. Also, it is very important to find the best compromise between these parameters after thermo-oxidative ageing. Figure 8 shows the same parameters after RTFO tests. Elvaloy AM exhibits the smallest changes in these properties. EVA, SBS-L and SBS-R showed significant changes after ageing. It indicates that hardening occurs during ageing as a consequence of a secondary reaction of degradation [5,18]. These changes are in agreement with the changes in rheological properties of BIT and PmBs after ageing.

Storage stability is one of the most critical aspects of modifying bitumen with polymers. Polymers contribute to the improvement of the rheological properties of bitumen, but on the other hand, create the multiphase nature of bitumen-polymer blends which are thermodynamically unstable and tend to separate macroscopically during storage at high temperatures [20]. Figure 8 shows the results of ring and ball temperatures of the top and the bottom part of PmBs after three days at 180°C. The softening points between the top and the bottom of the samples after the storage stability test are not higher than 4°C. These results indicate that there is no substantial phase separation, which results in good storage stability of all PmBs [11, 21].

**Table 2** Conventional properties of modified bitumen

Properties	Bitumen 70/100	SBS-L	SBS-R	EVA	Elvaloy AM
Penetration (1/10 mm)	71.1	56.9	64.1	63	66.7
Softening point, R&B(°C)	46.7	53.3	55.4	56.7	55
Penetration index (PI)*	-0.83	-0.11	0.70	0.26	0.72
Change in mass (%)	-0.21	-0.23	-0.20	0.17	0.1
Retained penetration (%)	62	54	53	48	61
Variation of softening point (°C)	0.5	11	12	14	4
Stability ΔT (°C)	/	0	0.1	0.1	0.4
Elastic recovery before RTFOT (%)	/	47	71	25	69
Elastic recovery after RTFOT (%)	/	54	75	16	62.5
Frass breaking point before RTFOT(°C)	-12	-14	-15	-7	-11
Frass breaking point after RTFOT(°C)	-13	-12	-17	-6	-14.5

\*PI=  $1952 - 500 \cdot \log(\text{pen}_{25}) - 20 \cdot \text{SP} / 50 \cdot \log(\text{pen}_{25}) - \text{SP} - 120$  [19];

pen<sub>25</sub> is the penetration at 25°C and SP is the softening point temperature of PmB

## 5 Conclusions

The rheological properties and resistance to permanent deformation of road BIT are improved by means of SBS-L, SBS-R, EVA and Elvaloy AM polymer modification. This has been proven by both conventional and rheological parameters  $G^*$ ,  $h^*$  and  $d$  obtained by DSR measurements. Furthermore, acceptable properties were obtained in this investigation by using a small amount of polymer, i.e. 2% wt. With the addition of polymer,  $G^*$  and  $h^*$  are increased and the elastic response is improved. All PmBs samples show good storage stability. Modification with the reactive polymer Elvaloy AM and SBS-R shows the elastic plateau, which indicates the formation of a physical network in BIT/SBS-R and a chemical network in BIT/Elvaloy AM. All PmB samples have higher critical temperatures, i.e. better resistance to permanent deformation/ rutting. After ageing, the hardening of BIT and PmBs occurred and the elastic response decreased as a consequence of degradation. The hardening is more pronounced in BIT and in BIT modified with EVA and the changes are less pronounced in the PmB modified with Elvaloy AM. PmBs modified with SBS-R and Elvaloy AM have the best relation between softening point, elastic behaviour and penetration value before and after thermo-oxidative ageing.

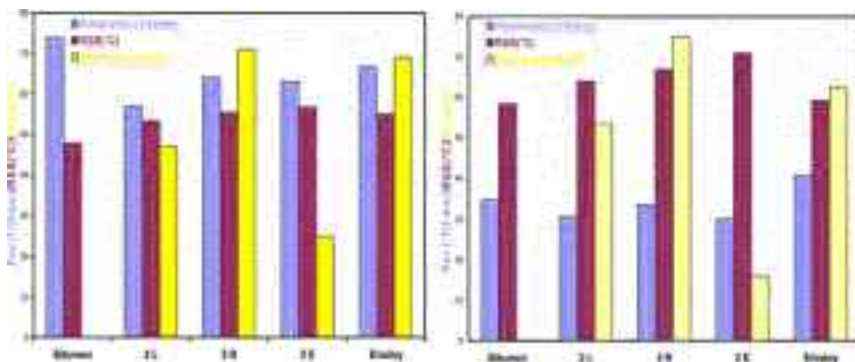

Figure 7 Softening point (R&B), penetration and elastic recovery for all before (left) and after (right) RTFOT

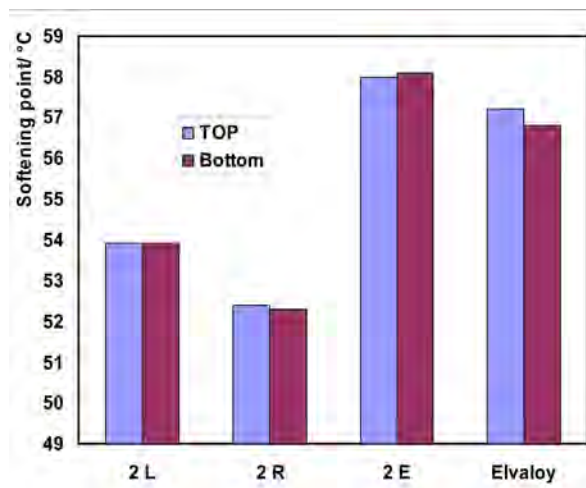
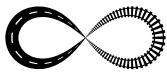

Figure 8 Storage stability

## References

- [1] Lesueur D.: The colloidal structure of bitumen: Consequences on the rheology and on the mechanisms of bitumen modification, *Advances in Colloid and Interface Science*, 145, p.p. 42-82, 2009.
- [2] McNally, T.: Polymer modified bitumen, First edition, UK, 2011.
- [3] Lu, X. & Isacsson, U.: Rheological characterization of styrene-butadiene-styrene copolymer modified bitumens, *Construction and Building Materials*, 11, p.p. 23-32, 1997.
- [4] Airey, G.D.: Styrene butadiene styrene polymer modification of road bitumens, *Journal of Materials Science*, 39, p.p. 951-959, 2004.
- [5] Rek, V., Vranješ, N. & Barjaktarović, Z. M.: Evaluation Of Ageing Properties Of Polymer Modified Bitumen, *Materials Research Innovations*, 9, p.p. 670-691, 2005.
- [6] Bulatović, V.O., Rek, V. & Marković, K. J.: Polymer Modified Bitumen, *Materials Research Innovations*, 16, p.p. 1-6, 2012.
- [7] Polacco, G., Stastna, J., Biondi, D., Antonelli, F., Vlachovicova, Z. & Zanzotto, L.: Rheology of asphalts modified with glycidylmethacrylate functionalized polymers, *Journal of Colloid and Interface Science*, 280, pp. 366-373, 2004.
- [8] Navarro, F. J., Partal, P., García-Morales, M., Martín-Alfonso, M.J., Martínez-Boza, F., Gallegos, C., Bordado, J.C.M. & Diogo, A.C.: Bitumen modification with reactive and non-reactive (virgin and recycled) polymers: A comparative analysis, *Journal of Industrial and Engineering Chemistry*, 15, pp. 458-464, 2009.
- [9] Keyf, S., Ismail, O. & Corbacioglu, B.D.: Polymer Modified Bitumen Using Ethylene Terpolymers, *Petroleum Science and Technology*, 25, pp. 915-923, 2007.
- [10] Rek, V. & Barjaktarović, Z. M.: Dynamic mechanical behavior of polymer modified bitumen, *Materials Research Innovations*, 6, p.p. 39-43, 2002.
- [11] Fu, H., Xie, L., Dou, D., Li, L., Yu, M. & Yao, S.: Storage stability and compatibility of asphalt binder modified by SBS graft copolymer, *Construction and Building Materials*, 21, p.p. 1528-1533, 2007.
- [12] Nejad, F. M., Aghajani, P., Modarres, A. & Firoozifar, H.: Investigating the properties of crumb rubber modified using classic and SHRP testing method, *Construction and Building Materials*, 26, pp. 481-489, 2012.
- [13] Lu, X., Isacsson, U.: Modification of road bitumens with thermoplastic polymers, *Polymer Testing*, 20, p.p. 77-86, 2001.
- [14] Airey, G. D. & Rahimzadeh, B.: Combined bituminous binder and mixture linear rheological properties, *Construction and Building Materials*, 18, p.p. 535-548, 2004.
- [15] Airey, G. D.: Rheological evaluation of ethylene vinyl acetate polymer modified bitumens, *Construction and Building Materials*, 18, pp. 473-487, 2002.
- [16] Becker, M. Y., Müller, A. J., Rodriguez, Y.: Use of Rheological Compatibility Criteria to Study SBS Modified asphalts, *Journal of Applied Polymer Science*, 90, pp.1772-1782, 2003.
- [17] Sengoz, B., Isikyakar, G.: Evaluation of the properties and microstructure of SBS and EVA polymer modified bitumen *Construction and Building Materials*, 22, p.p. 1897-1905, 2008.
- [18] Bonemazzi, F., Braga, V., Corrieri, R., Giavarini, C., Sartori, F.: Characteristics of polymers and polymer-modified binders, *Transportation Research Record* 1535, pp. 36-47, 1996.
- [19] Lu, X. & Isacsson, U.: Chemical and rheological evaluation of ageing properties of SBS polymer modified bitumens, *Fuel* 77, p.p. 961-972, 1998.
- [20] Read, J., Whiteoak, D.: *The Shell Bitumen Handbook*, 5th edition, London, 2003.
- [21] Polacco, G., Stastna, J., Vlachovicova, Z., Biondi, D. & Zanzotto, L.: Temporary Networks in polymer-Modified Asphalts, *Polymer Engineering and Science*, 44, pp. 2185-2193, 2004.
- [22] Dehouche, N., Kaci, M., Mokhtar, K.A.: Influence of thermo-oxidative aging on chemical composition and physical properties of polymer modified bitumens, *Construction and Building Materials*, 26, pp. 350-356, 2012.



## THE COMPARISON BETWEEN WHEEL TRACKING AND TRIAXIAL CYCLIC COMPRESSION TEST ON DIFFERENT ASPHALT MIXTURES

Nataša Zavrtanik<sup>1</sup>, Roman Bašelj<sup>1</sup>, Mitja Kozamernik<sup>1</sup>, Goran Turk<sup>2</sup>, Marjan Tušar<sup>3</sup>

<sup>1</sup> IGMAT d.d., Building materials institute, Slovenia

<sup>2</sup> Faculty of civil and geodetic engineering, University of Ljubljana, Slovenia

<sup>3</sup> National institute of chemistry, Slovenia

### Abstract

Road structural materials should have satisfactory behaviour that enables a proper load carrying capacity. Asphalt mixtures used in road construction must be resistant to permanent deformations and cracking caused by temperature changes and fatigue. Road damages caused by the impact of different factors don't have equal impact on all layers of road construction and can manifest in various forms.

To determine the resistance to permanent deformations at high temperatures of asphalt specimens, triaxial cyclic compression and wheel tracking tests were done. We have made wheel tracking tests according to the SIST EN 12697-22 standard and triaxial cyclic compression tests according to the SIST EN 12697-25 standard, method B. Experiments were done for all asphalt mixtures regularly used in Slovenia: AC, SMA, MA and PA to obtain an extensive model of asphalt behaviour for mixtures containing high and low air void content. Mastic asphalt dictated the use of harder bitumen in all mixtures with the intention to compare results of wheel tracking test and cyclic compression test for four asphalt mixtures. The results will be interpreted with a statistical model.

*Keywords: asphalt mixtures, triaxial test, wheel tracking test, proportional rut depth, strains, stability*

### 1 Introduction

Our main intention was to obtain an extensive model of asphalt behaviour for mixtures containing high and low air void content. We would like to compare the results of triaxial tests and wheel tracking tests for all types of asphalt mixtures regularly used in Slovenia: Asphalt Concrete (AC), Stone Mastic Asphalt (SMA), Mastic Asphalt (MA) and Porous Asphalt (PA). All tested asphalt mixtures have maximal grain size of 11mm and were once mixed with road bitumen B20/30 and once with polymers modified bitumen PmB10/40-65. Here we have to mention, that triaxial cyclic compression tests were done on Slovenian asphalt mixtures for the first time. We intended to compare results of wheel tracking test and cyclic compression test for four asphalt mixtures. The main goal of this study was a calculation of an accurate model for relation between wheel tracking test and cyclic compression test.



## 1.1 Short review of literature

In [1] and [2] authors describe new approaches to asphalt testing, which is performance based testing. Among other things they describe also the triaxial cyclic compression test.

Because conventional test methods used to indicate the resistance against rutting don't discriminate between convention and modern mixes, now in Netherlands cyclic triaxial test are used. Author in [3] describes a method in which the triaxial test data is used to predict the rut propagation on asphalt concrete. In [4] authors measured creep compliance for dense asphalt mixtures and porous mixtures depending on different shapes of wave-form of applied load and different test specimens height. Paper [5] presents a study of effect of air voids content on the mixture strength properties. Researchers investigated two mixtures (Dense Graded Mix and Stone Mastics Asphalt) with triaxial shear strength test. In [6] authors investigated the rutting behaviour of bituminous materials with different air void contents.

## 2 Materials and tests

### 2.1 Binder, aggregate, binder and void content

All mixtures were made out of two types of binder: road bitumen B20/30 and with polymers modified bitumen PmB10/40-65.

Asphalt mixtures were made of limestone aggregate with maximum grain size which passes through square sieve with maximum size of 11 mm. With the intention of result comparison of wheel tracking test and triaxial cyclic compression test, all four asphalt mixtures were made out of same limestone aggregate with equal maximum grain size (AC11, SMA11, PA11 and MA11).

Table 1 presents binder and void content values of asphalt mixtures. It is seen that for all tested types of asphalt mixtures containing polymers modified bitumen have more voids than asphalt mixtures containing paving grade bitumen. This can be explained with higher resistance to compaction of asphalt mixtures containing PmB, due to higher softening point of PmB binder. Softening point (ring and ball test) for PmB10/40-65 is measured at 75.1°C and for B20/30 is 62.9°C. But it is also known that even if the softening points of PmB (with SBS modifier) and paving grade bitumen are the same, it is always harder to compact asphalt mixtures containing PmB.

**Table 1** Binder and void content, binder and void content values of asphalt mixtures.

Property	Binder content (m/m) [%]	Filler content (m/m) [%]	Void content (V/V) [%]	Void filled with bitumen [%]
Method	EN 12697-1	EN 12697-2	EN 12697-8	EN 12697-8
AC	5.2	7.7	2.5	83.4
AC PmB	5.2	7.7	3.6	77.4
SMA	6.5	8.0	2.3	86.6
SMA PmB	6.5	8.0	2.9	83.5
PA	5.0	3.6	15.8	39.3
PA PmB	5.0	3.6	19.8	32.8
MA	7.0	27.2	1.5	91.6
MA PmB	7.0	27.2	1.9	89.7

## 2.2 Triaxial cyclic compression test

We have conducted a triaxial cyclic compression test according to the SIST EN 12697-25 standard, method B. The cylindrical specimen in the triaxial test is subjected to a confining stress and a cyclic axial stress at elevated conditioning temperature and vertical plastic deformation is measured. Specimens are subjected to the constant confining pressure  $\sigma_c$  and haversinoidal cyclic vertical pressure  $\sigma_a$ . Test specimens were prepared in the laboratory by an impact compactor (Marshall specimens). High-to-diameter ratio of the specimens was 0.6, because of the nominal aggregate size of 11mm. Test temperature was 50°C for all specimens. Fig. 1 represents permanent deformation curves depending on the number of load cycles. We can notice, what is also expected, that mastic asphalt (MA) is far away from others and also mixes with polymer modified bitumen behave better under cyclic compression load than mixes with road bitumen do.

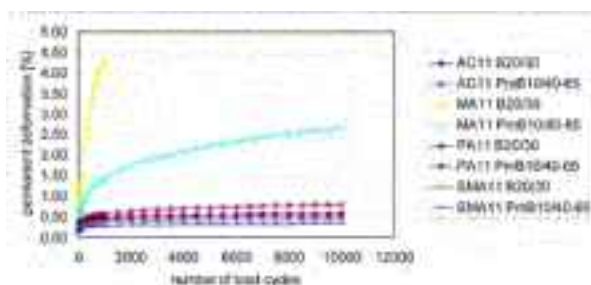

Figure 1 Permanent deformation curve for different types of asphalt.

## 2.3 Wheel tracking test (WTT)

We have made wheel tracking tests according to the SIST EN 12697-22 standard with a small – size device in the air (procedure B). Specimens for all asphalt mixtures were laboratory prepared. Thickness of the specimens was 40 mm, because mixtures with maximal grain size of 11mm were tested. Test temperature was 60°C for all specimens. This temperature is required in Slovene national specifications. Fig. 2 represents permanent deformation curves depending on the number of load cycles. We can notice, what it is again expected, that mastic asphalt (MA) is far away from others types of asphalt. Very similar are deformation curves for AC and SMA made of polymer modified bitumen and they have also the best behaviour under load.

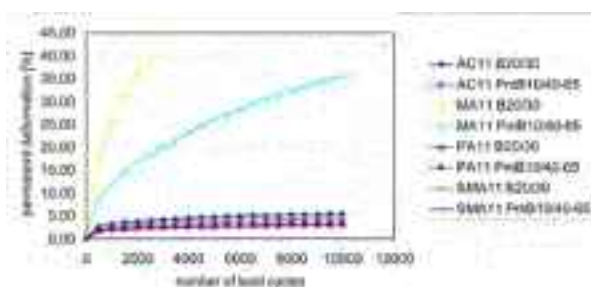

Figure 2 Permanent deformation curve for different types of asphalt.

## 2.4 Marshall stability test

Additionally, on all asphalt mixtures the Marshall stability test, according to the EN 12697-34 standard was performed. In new European standards for asphalt specifications (standards EN 13108) this test is required only for airfields. In the past this test was mainly performed on AC mixes in scope of quality control. We expected some relevant results due to the fact that the test temperature is 60°C; this is the same as wheel tracking test temperature. It should be stressed that for the SMA samples it is hard to determine the point of maximum force. This mostly affects the accuracy of flow (F) determination. Results of the Marshall stability test for SMA have shown, that at the steepest part of curves slopes are reproducible. What makes a more accurate and reliable parameter than flow (F) is determined from the slope of tangential flow (Ft). For modelling we decided that it is better to take into account the tangential flow (Ft) than flow (F). Instead of Marshall quotient (S/F), quotient between stability and tangential flow (S/Ft) was used for modelling.

## 3 Test results

From Figures 3 and 5 it can be seen that results of wheel tracking and triaxial test for mastic asphalt (MA) were far from the result for other types of asphalts. Due to extensive permanent deformations both tests on MA samples containing paving grade bitumen were stopped before the end of test. Table 2 shows some final results.

First we assumed that strain ( $\epsilon_{10000}$ ) and proportional rut depth are related so we graphically compared results (Fig. 3 and Fig. 4). From Fig. 3 it can be seen that asphalt mixtures containing PmB are, for all four types of asphalt mixtures, more resistant to rutting than asphalt mixtures containing paving grade bitumen B20/30. Surprisingly, from Fig. 4 it can be seen that both SMA asphalt mixtures (containing PmB and containing paving grade bitumen B20/30) are more resistant to permanent deformation than other asphalt mixtures when triaxial test is performed. It must be stressed that wheel tracking test according to EN 12697-22 was performed at 60°C and triaxial test according to EN 12697-25 at 50°C. From Table 2 it can be seen that values of tangential flow (Ft) for asphalt mixtures containing PmB are not always lower than for asphalt mixtures containing B20/30. From this we can conclude that simple relations between usage of modified bitumen and asphalt properties are not a rule.

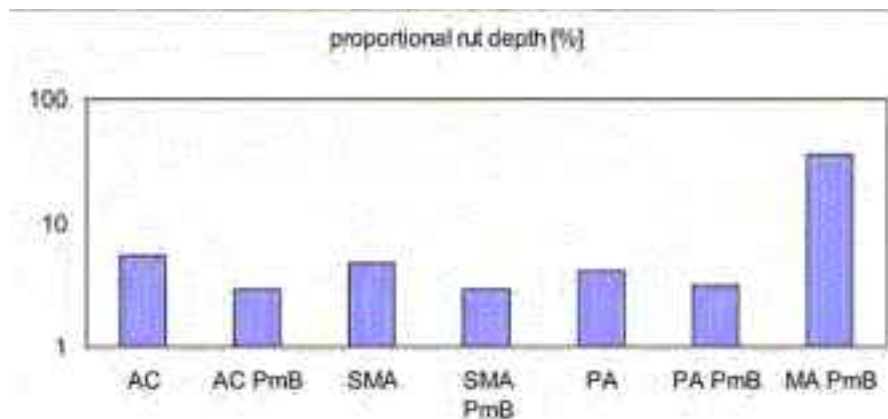

Figure 3 Proportional rut depth for 7 asphalt mixtures is a result of the wheel tracking test according to EN 12697-22.

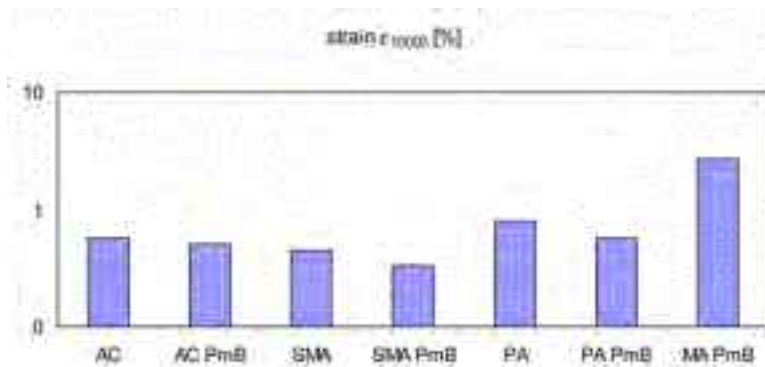

Figure 4 Strain ( $\epsilon_{10000}$ ) for 7 asphalt mixtures as one of the results of triaxial test according to EN 12697-25.

Table 2 Results of mechanical tests on asphalt mixtures.

Property	Stabil. (S)	Tangent. flow (Ft)	Quot. (S/Ft)	Strain ( $\epsilon_{10000}$ )	Max. def.	Proport. rut depth	WTS
	[kN]	[mm]	[kN/mm]	[%]	[mm]	[%]	[mm/1000]
Method EN 12697	34	34	34	25	25	22	22
AC	17.6	2.5	7	0.577	0.367	5.44	0.059
AC PmB	20.4	2	10.2	0.505	0.322	2.87	0.026
SMA	11.3	1.4	8	0.442	0.285	4.73	0.046
SMA PmB	13.7	1.8	7.9	0.329	0.210	2.87	0.028
PA	8.4	1.1	7.9	0.799	0.487	4.11	0.046
PA PmB	8.9	1.5	5.9	0.569	0.352	3.16	0.031
MA PmB	20.9	4.9	4.3	2.657	1.646	35.5	0.785
MA	21.4	3.4	6.3	4.292 (1000 load cycles)	2.637 (1000 load cycles)	39.6 (2500 load cycles)	-

## 4 Modelling

First we checked the simple linear relation between strains ( $\epsilon_{10000}$ ) obtained with the triaxial test and proportional rut depth. From Fig. 5 we can see that correlation coefficient is promising if MA PmB is included (left), but there is practically no relation for other asphalt mixtures (when MA PmB not included) (right).

To improve the model we included data from the asphalt composition and the Marshall test. We selected bitumen content, content of stone aggregates passing characteristic sieve of 2mm and quotient between stability and tangential flow. With the linear model we obtained an extremely good correlation coefficient when MA PmB data is included ( $r^2=0.9996$ ) and fairly good ( $r^2=0.981$ ) when MA PmB data is excluded from the training set. In Table 3 we can compare measured results of proportional rut depth and proportional rut depth calculated from the linear model of type: Proportional rut depth (%) =  $a_1 * (\text{strain } (\epsilon_{10000})) + a_2 * \text{bitumen } [\%] + a_3 * 2 \text{ mm } [\%] + a_4 * S/Ft + b$ . We must be aware that such a model is useful only for asphalt mixtures with maximum grain size of 11mm and limestone aggregate, but it can be the base for a more common model. For other asphalt mixtures we can expand the model with including additional factors, such as bitumen softening point, filler content and content of stone aggregates passing all other sieves of 2mm etc.

In future we will try to validate the proposed model with additional experiments on asphalts with different sieving curves and different bitumen origin. It is strange that in the proposed model softening point and filler content were not selected as factors, but we suppose that the results from the Marshall test also inherently include some about data softening point and filler content. For the second model we used measured proportional rut depth after 2500 load cycles instead of the proportional rut depth after 10000 load cycles and strain after 1000 load cycles ( $\epsilon_{1000}$ ) instead of the strain after 10000 load cycles ( $\epsilon_{10000}$ ). In the second model we were able to include data from MA asphalt mixture containing paving grade bitumen (B20/30). When all eight asphalt mixtures were included in the linear model, we again obtained good correlation coefficient ( $r^2=0,998$ ).

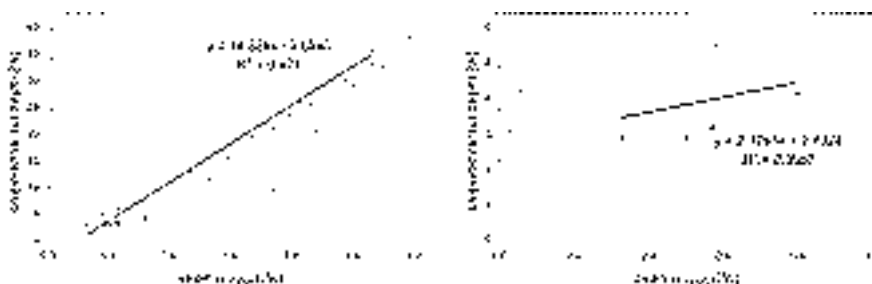

Figure 5 Proportional rut depth/strains ( $\epsilon_{10000}$ ).

Table 3 Results of measured Proportional rut depth and Proportional rut depth calculated from the linear model mixtures.

Property	Measured proportional rut depth [%]	Calculated proportional rut depth [%]
Method	EN 12697- 22	Linear model
AC	5.44	5.55
AC PmB	2.87	2.77
SMA	4.73	4.37
SMA PmB	2.87	3.23
PA	4.11	4.29
PA PmB	3.16	2.97
MA PmB	35.5	35.51

## 5 Conclusion

We've made wheel tracking tests and triaxial cyclic compression tests for all asphalt mixtures regularly used in Slovenia: AC, SMA, MA and PA. First we expected a simple linear relation between results obtained with triaxial test and results obtained with the wheel tracking tests, but we found poor correlation. When we included data from the Marshall stability test, bitumen content and content of stone aggregates passing characteristic sieve of 2mm in a linear model we got extremely good correlations. Due to the fact that the selected statistical model includes mixtures containing high and low air void content we expect it can be useful for a rough prediction of rut propagation from the triaxial cyclic compression test and the Marshall stability test results.

## Acknowledgement

This work has been financially supported by the European Union, European Social Fund. The support is gratefully acknowledged.

## References

- [1] Brown, E.R. & Kandhal, P.S. & Zhang, J.: Performance testing for hot mix asphalt, NCAT Report 01-05, Auburn University, 2001.
- [2] Tušar, M.: Strokovni prispevki, Novosti pri laboratorijskih preiskavah, ZAS, Od skupščine do skupščine 11., ZAS, pp. 23-26, 2007.
- [3] Huurman, N.: Cyclic triaxial tests on asphalt concrete relating to rutting, 2th Eurasphalt & Eurobitume, Barcelona, pp. 351-363, 2000.
- [4] Huurman, J.M.M. & Huurman, A.A.A.: Susceptibility to permanent strain of asphalt in the dynamic triaxial compression creep test, 2th Eurasphalt & Eurobitume, Barcelona, pp. 490-499, 2000.
- [5] Pellinen, T.K. & Song, J. & Xiao, S.: Characterization of hot mix asphalt with varying air voids content using triaxial shear strength test, 8th Conference on asphalt pavements for Southern Africa, South Africa, 2004.
- [6] Popp, K., Kruse, H. & Kaiser, I.: Nonlinear properties analyses on rutting behaviour of bituminous materials with different air void contents, Construction and Building Material, 23, pp. 3492-3498, 2009.



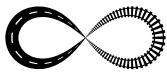

## CREEP RECOVERY BEHAVIOUR OF BITUMINOUS BINDERS—RELEVANCE TO PERMANENT DEFORMATION OF ASPHALT PAVEMENTS

Georges A. J. Mturi, Matsopole Nkgapele, Johan O'Connell

*CSIR Built Environment, Transport Infrastructure Engineering, Pretoria 0001, South Africa*

### Abstract

The increase in traffic loads and loading time in road pavements worldwide has resulted in the widespread usage of polymer modified binders (PMBs) since they offer increased resistance to pavement distresses. The extensive use of inherently different modifiers has expanded the range of PMBs to select from when designing pavements in order to avoid pavement deformation. The new binder selection criterion using the Multiple Stress Creep and Recovery (MSCR) protocol as per ASTM D7405 is meant to differentiate the resistance to permanent deformation of different road binders. The MSCR test is essentially a repeated creep–recovery test at a fixed loading/unloading interval. This paper aims to show how creep tests can differentiate the resistance to permanent deformation for different bituminous binders, whether modified or unmodified. The paper will also illustrate creep as a time–dependent deformation phenomenon that is specific to the rate and magnitude of traffic load.

*Keywords: multiple stress creep and recovery, permanent deformation*

### 1 Introduction

Bituminous binders are viscoelastic materials with a time and temperature dependent response to loading. One of the major aims of researchers has been to characterise the elastic response of road binders in order to predict their resistance to permanent deformation. The previous Superpave parameter used for predicting rut resistance had limitations, especially in characterising the performance of polymer modified binders [1]. The new MSCR protocol as per ASTM D7405 measures the non–recoverable compliance of a binder subjected to multiple loads. This test assumes the behaviour of in situ bituminous binders in any pavement structure can be characterised at two stress levels. It also aims to classify road binders based on the extent to which they recover when subjected to the same creep loading/unloading condition. However, the variety of additives used in modifying bituminous binders worldwide has widened the viscoelastic properties of PMBs between viscoelastic liquids and viscoelastic solids at the in–service pavement temperatures. This means that the rate and extent of recovery could differ per binder, per load. This highlights the importance of characterising binders based on a number of loading cycles and loading time, especially when predicting long term permanent deformation [2].

This paper aims to show the challenges of the MSCR concept in predicting rut resistance. It explores the difficulty in characterising binders based on their ability to recover after being subjected to repeated creep loads at a defined rate and magnitude.



## 2 Experimental

Rheological analyses in this paper were conducted using an Anton Paar Physica Smartpave Plus Dynamic Shear Rheometer (DSR) that uses a Peltier system with a parallel plate measuring configuration. This was consistent with ASTM D7175 (Standard Test Method for Determining the Rheological Properties of Asphalt Binder Using a Dynamic Shear Rheometer) and ASTM D7405 (Multiple Stress Creep and Recovery of Asphalt Binder Using a Dynamic Shear Rheometer). All measurements were done using the 25-mm diameter measuring spindle at a 1-mm gap setting.

All samples were conditioned at the appropriate test temperature prior to testing. Binders were tested at their SHRP ( $G^*/\sin\delta = 1\text{ kPa}$ ) rutting test temperature limit. Five binders were investigated: a 40/50 open grade binder with a SHRP test temperature of 67°C; two SBS-modified binders (SBS at 73°C and SBS at 70°C); waxy HiMA binder at 75°C and a non-waxy HiMA at 82°C.

## 3 Multiple creep recovery behaviour of viscoelastic material

The MS CR test is meant to analyse the creep recovery behaviour of road binders subjected to multiple loads. The MS CR test involves applying a 1 second creep loading followed by a 9 second recovery over the multiple stress levels of 25, 50, 100, 200, 400, 800, 1600, 3200, 6400, 12800 and 25600 Pa. At each stress level, 10 loading cycles are applied. The non-recoverable compliance ( $J_{nr}$ ) is the measured property, defined as the average non-recovered strain for the 10 creep and recovery cycles divided by the applied stress for those cycles. An accumulation of the non-recoverable compliance will result in permanent deformation of the binder over time.

Fig. 1a shows  $J_{nr}$  values at different stresses for an SBS modified binder and a 40/50 open unmodified binder at their SHRP rutting test temperature (where  $G^*/\sin\delta = 1\text{ kPa}$ ). The figure shows the modified binder is more stress resilient than the unmodified binder at a range of stress levels up to a certain threshold limit. This is the stress where the % non-recoverable compliance drastically increases and the binder displays reduced resistance to permanent deformation. This happens earlier for the SBS modified binder than for the unmodified bitumen. Fig. 1b shows two HiMA binders (a waxy and non-waxy modified binder) with very different behaviour. The waxy HiMA binder seemed stress sensitive whereas the non-waxy HiMA binder behaved more like an unmodified binder with fixed  $J_{nr}$  values up to a certain stress threshold.

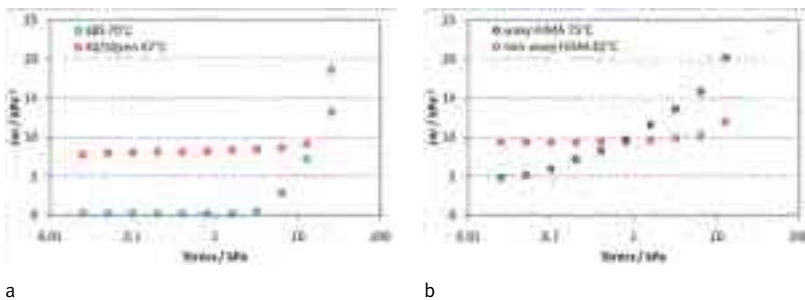

**Figure 1** Comparison of  $J_{nr}$  values at various stresses of (a) an unmodified binder (40/50 open) and a modified binder (SBS-modified), (b) a waxy and a non-waxy HiMA binder at their SHRP ( $G^*/\sin\delta = 1\text{ kPa}$ ) rutting test temperature.

The two SBS modified binders in Fig. 2 seem similar in their resistance to permanent deformation up to a certain stress threshold, above which they display different rates of changes, i.e. the two binders exhibit dissimilar non-linear viscoelastic behaviour.

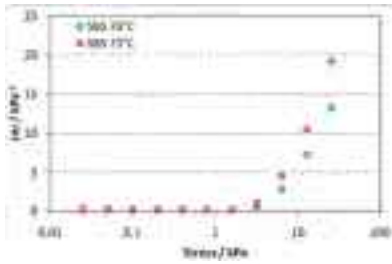
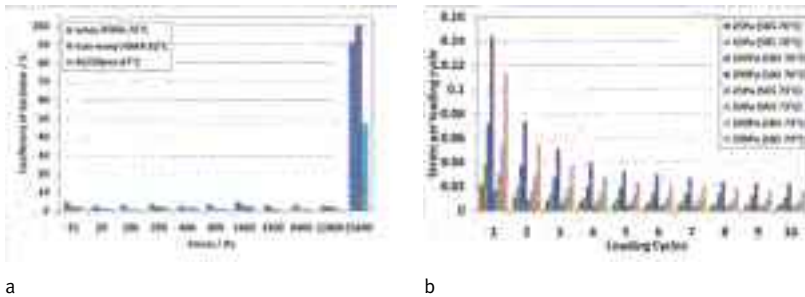

**Figure 2** Non-recoverable compliance at various stresses of modified binders at their SHRP ( $G^*/\sin\delta = 1\text{ kPa}$ ) rutting test temperature.

Zaoutsos [3] has shown with polymers that the strain of a constant applied stress increases after every successive loading step. Consequently, the reproducibility in the non-recovery compliance values of the binders during the stress/recovery cycles was investigated at different stress levels. The results are displayed in Fig. 3a.

The binders in Fig. 3b only exhibited high coefficient of variation values at the very highest stress level. The source in the poor reproducibility of non-recoverable compliance values after each loading cycle warrants further investigation. But it seems to suggest that non-recoverable compliance values may be affected by the number of loading cycles only at the highest stress level.

The un-recovered strain at the lower stress levels of SBS modified binders decreases with each loading cycle (see Fig. 3b) opposite to what Zaoutros [3] has shown with polymers. Successive cyclic loading simply does not allow these binders to fully recover hence the justification of averaging un-recoverable strain values obtained per loading cycle, as suggested by ASTM D7405, may not hold.



**Figure 3** (a) Coefficient of variation of the strain values for the 10 loading cycles applied at each stress level for the different binders at their SHRP ( $G^*/\sin\delta = 1\text{ kPa}$ ) rutting test temperature. (b) Strain values for 10 loading cycles applied at stress levels of 25, 50, 100 and 200Pa for the SBS 70°C and SBS 73°C.

Fig. 4a and 4b reveal the behaviour of the SBS modified binders at loading cycles of different stress and rest phase duration. An increase in the duration of the applied stress shows a notable variation in the non-recoverable compliance values, especially at the non-linear viscoelastic region. Loading times longer than 3 s were not used in order to avoid sample damage and tertiary flow [2], [4]. Fig. 4b shows that a longer rest phase duration results in greater recovery of the SBS modified binders.

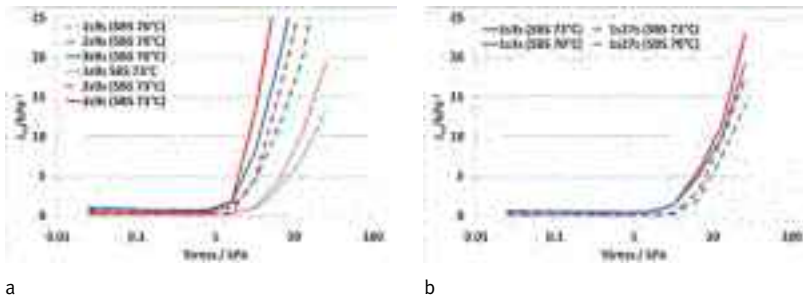

**Figure 4** Loading cycles at different stress (a) and rest (b) phase duration for the SBS modified binders at their SHRP ( $G^*/\sin\delta = 1\text{kPa}$ ) rutting test temperature.

Multiple loads due to moving traffic on a pavement surface will vary with traffic load (stress), speed (loading time or creep time) and volume (recovery time). It remains a challenge to account for all the variations in traffic in a testing protocol.

#### 4 Predicting permanent deformation

The Repeated Simple Shear Test at Constant Height (RSST-CH) was used for the determination of permanent shear strain of asphalt specimens. The shear test was conducted at constant height with a horizontal shear force of 69kPa applied to a cylindrical asphalt specimen in accordance with the standard ASSHTO 320-03 protocol but with certain deviations by Denne-man [5]. The shear load is applied for 0.1 second followed by a 0.6 second rest period for a defined number of repetitions. The property measured is the permanent shear strain, defined as the horizontal deformation divided by the height of the asphalt specimen. The rate of accumulation of the permanent shear strain in the specimen during the test is used to predict permanent deformation in the field.

Three continuously and similarly graded mix specimens were prepared using the waxy HiMA, non-waxy HiMA and the SBS (73°C) modified binders. The mix specimens were then aged for four hours in an oven at their calculated compaction temperature in order to simulate the short-term ageing (STA) that a binder undergoes during hot mix asphalt (HMA) manufacture, transport to site and laying. Thereafter, the asphalt mixes were compacted to their design densities (approximately 5% air voids). The shear tests were conducted at 55°C and run up to 5 000 repetitions or 5% permanent strain, whichever was reached first. This is because in South Africa, the maximum surface temperature of road pavements ranges between 45°C and 55°C generally [6].

Fig. 5 shows average permanent strain curves, each based on three tested specimens per mix. The use of similar mix designs means that the observed differences in permanent strain measurements between mixes can only be attributed to the in-situ binder performance.

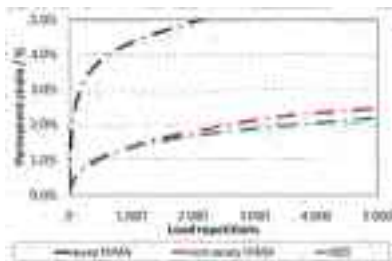

**Figure 5** Shear deformation curves for different mix specimens at design density and tested at 55°C (RSST-CH).

The non-waxy HiMA mix exhibited the best resistance to rutting during the early load repetitions. But the SBS modified binder showed better permanent strain resistance beyond 1000 load repetitions. The waxy HiMA mix had the poorest resistance to rutting; accumulating the 5% permanent strain level before the 5000 load repetitions.

The empirical properties would have predicted the HiMA mixes to perform similarly in terms of rutting since the two binders belong to the same specification class. According to the SHRP rutting parameter, the non-waxy HiMA mix should exhibit superior rutting performance compared to the others, which would have been anticipated to perform similarly. Both the empirical test results and the SHRP parameter ( $G^*/\sin\delta$ ) fails to predict the asphalt performance displayed in Fig. 5.

The RSST-CH test was carried out at the same temperature for the different asphalt specimens. In order to link binder behaviour to mix performance, bitumen samples were re-tested at the same temperature as the mixes. Additionally, the asphalt specimens were subjected to multiple loads. As a result, a better binder test for predict rutting is needed to measure the elastic response of the binder after multiple loads instead of the elastic component of the binder at a fixed frequency.

The MSCR test was used to predict the resistance to rutting of asphalt mixes subjected to multiple stress loads. Fig. 6a contains the non-recoverable compliance curves of the three binders used to make the three mixes at 55°C. The virgin SBS modified binder was the most stress resilient up to a certain stress threshold. The virgin non-waxy HiMA binder showed non-recoverable compliance levels close to the SBS modified binder. Unlike the SBS modified binder though, it showed consistent stress resilience even at high stress levels. The virgin waxy HiMA binder was the poorest in resisting creep stress and it exhibited an increase in non-recoverable compliance values at a much lower stress level compared to both the SBS-modified and non-waxy HiMA binders. This suggested that the binder was stress sensitive. In order to simulate the properties of the binder in the short term aged asphalt specimens, RTFOT-aged binders were also tested. The results are shown in Fig. 6b.

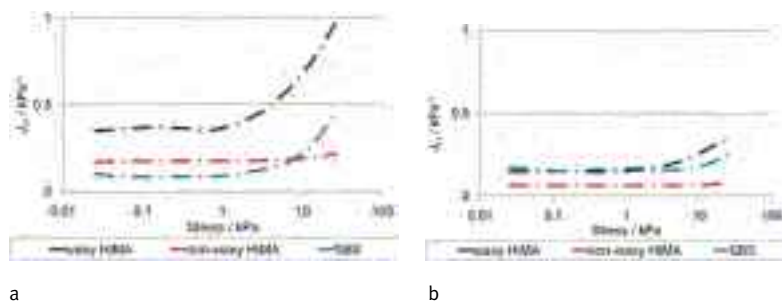

**Figure 6** (a) Non-recoverable compliance at different stress levels of bituminous binders at 55°C. (b) Non-recoverable compliance at different stress levels of bituminous binders after RTFO-aging at 55°C.

Both the HiMA binders showed improved stress resilience after RTFOT-aging but the SBS modified binder decreased instead. The non-waxy HiMA binder had the lowest non-recoverable compliance values and would be expected to perform the best in a similar mix. The non-recoverable values of the SBS modified binder and the waxy HiMA binder were similar after RTFOT-aging, although the latter showed a lower stress threshold i.e. more stress sensitive. Provided the stress of the waxy HiMA binder in the mix does not surpass the stress threshold, the resultant mix was expected to show similar resistance to deformation as the mix with the SBS modified binder. Fig. 5 shows the corresponding mix performance was different to these predictions.

## 5 Addressing the limitations of the MSCR prediction

The non-recoverable compliance results of the RTFOT-aged binders failed to accurately predict the rutting performance of mixes made from the different binders. The poor prediction can be attributed to two factors. Firstly, it is due to the incorrect simulation of short-term ageing made by the RTFOT procedure for the waxy HiMA binder. The pseudoplastic nature of the binder means that a much lower mixing and compaction temperature was required to achieve the workability viscosity than that of the non-waxy HiMA binder. Consequently the waxy binder would have aged a lot less during mixing and compaction than simulated by the RTFOT short-term ageing procedure. The non-recoverable compliance behaviour of the in-situ waxy HiMA binder is expected to be between the virgin binder and the RTFOT-aged sample. Secondly, average non-recoverable compliance values of 10 loading cycles are misleading considering the creep recovery behaviour of the SBS-modified binder varies with stress/rest intervals and with loading cycles. A more accurate mix rutting prediction for the RSST-CH test would entail:

- Using the recovered waxy HiMA binder from the mix test specimens.
- Conducting the test as per the creep/recovery cycle times of the RSST-CH test.
- Increasing the number of loading cycles to properly characterise the SBS modified binder performance.
- Performing the creep test at a stress level similar to that experienced by the binder in the mix.

The above recommendations were adopted during further testing, but the stress level experienced by the in situ binder in the mix could not be determined. Therefore, a stress level of 3200Pa was used as recommended by D'Angelo [7].

Lesser ageing of the recovered waxy HiMA binder makes it more stress sensitive and less stress resilient (see Fig. 7a). Fig. 6b had shown the non-recoverable values of the SBS modified binder and the waxy HiMA binder to be similar after RTFOT-ageing (below their stress threshold) but Fig. 7b shows a different picture. The SBS modified binder has poor resistance to initial stress loads but becomes significantly more load resistant (than the RTFO-aged waxy HiMA binder) with increasing loading cycles. This change in creep/recovery behaviour of the SBS-modified binder cannot be predicted with the Multiple Stress Creep and Recovery test since it averages non-recoverable compliance values for 10 loading cycles of each stress load.

The binder strain results in Fig. 8a shows a better rutting prediction of the shear deformation behaviour of the resultant asphalt mixes. Fig. 8a and 8b shows the mix with the SBS modified binder having a reduced rate of strain accumulation with loading cycles compared to the other binders. This may explain why this mix initially looked poorer than the non-waxy HiMA but became more resistant to deformation at increased loading cycles.

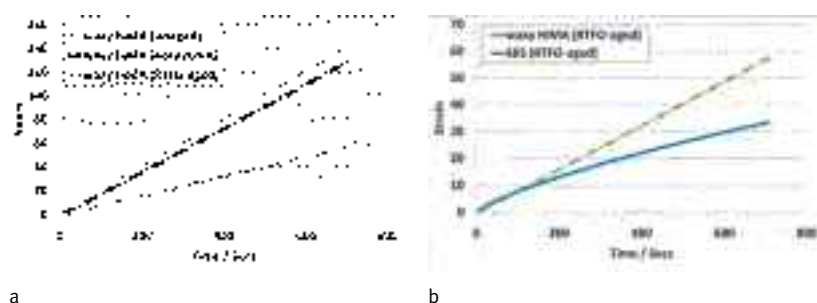

**Figure 7** (a) Strain deformation curves for the unaged, RTFO-aged and recovered waxy HiMA binders at 55°C for 1000 loading cycles at a 0.1 second creep load followed by a 0.6 second rest period at a stress of 3200Pa. (b) Strain deformation curves for the RTFO-aged waxy HiMA and SBS-modified binders at 55°C for 1000 loading cycles at a 0.1 second creep load followed by a 0.6 second rest period at a stress of 3200Pa.

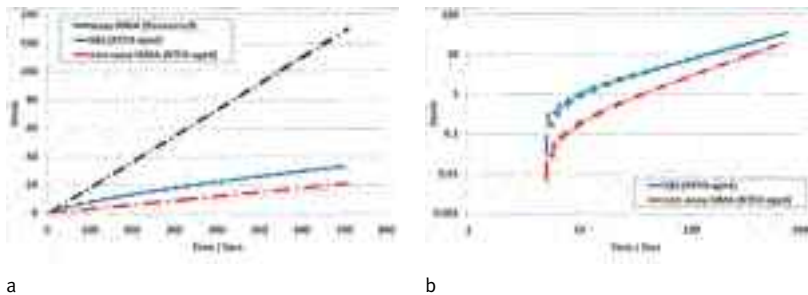

**Figure 8** (a) Strain deformation curves for the binders at 55°C for 1000 loading cycles at a 0.1 second creep load followed by a 0.6 second rest period at a stress of 3200Pa. (b) Log-log plot strain deformation curves for the SBS modified binder and the non-waxy HiMA at 55°C for 1000 loading cycles at a 0.1 second creep load followed by a 0.6 second rest period at a stress of 3200Pa.

## 6 Conclusion

The Multiple Stress Creep and Recovery test has been developed to predict the resistance to permanent deformation of road binders in asphalt pavements. It is intended to replace both the Superpave PG system and traditional empirical tests. This paper has highlighted the shortcomings of this method. In fixing the number of loading cycles and the stress/rest phase intervals, the method fails to simulate actual pavement loading/unloading conditions. It is also not known whether the stipulated stress levels in the method are representative of actual pavement stress loads experienced by the 'in situ' binder. Consequently, the MSCR protocol may fail to predict actual performance of modified binders whose creep/recovery behaviour varies with loading/unloading conditions. It remains a challenge to predict permanent deformation behaviour of road binders based on traffic conditions.

## References

- [1] Bahia, H.U., Hanson, D.I., Zeng, M., Zhai, H., Khatri, M.A. & Anderson, R.M.: Characterization of Modified Asphalt Binders in Superpave Mix Design. National Cooperative Highway Research Program, NCHRP Report 459, National Academy Press, Washington, 2001.
- [2] Delgadillo, R., Bahia, H.U. & Lakes R.: A Nonlinear Constitutive Relationship for Asphalt Binders, *Materials and Structures*, 45, pp. 457-473, 2012.
- [3] Zaoutsos, S.P.: Study of the Influence of Multiple Step Creep/Creep-Recovery Loading on the Nonlinear Viscoelastic Response of Carbon Fiber Polymer Matrix Composites, *Proceedings of the 11th WSEAS International Conference on Sustainability in Science Engineering*, ISBN: 978-960-474-080-2, 2009.
- [4] Motamed, A., Bhasin, A. & Liechti, K.M.: Interaction Nonlinearity in Asphalt Binders, *Mechanics of Time Dependent Materials*, Accepted – April, 2011.
- [5] Denneman, E.: Report on Protocol Development for the Determination of Permanent Shear Strain and Complex Shear Modulus using the Simple Shear Tester (SST), 2009, Senior Researcher, Council for Scientific and Industrial Research (CSIR), Pretoria, South Africa.
- [6] Denneman, E.: The Application of Locally Developed Pavement Temperature Prediction Algorithms in Performance Grade (PG) Binder Selection, 26th Annual Southern African transport conference, Pretoria, South Africa, July, 2007.
- [7] D'Angelo, J.: New High-Temperature Binder Specification Using Multistress Creep and Recovery, *Transportation Research Circular E-C147: Development in Asphalt Binder Specifications*, 2010.



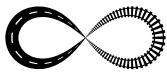

## EVALUATION OF THE EFFECT OF AGGREGATES ANGULARITY ON THE SURFACE PROPERTIES OF HOT MIX ASPHALT

Amir Onsoni, Burak Sengoz, Ali Topal, Cagri Gorkem

*Dokuz Eylul University, Faculty of Engineering, Department of Civil Engineering, Division of Transportation Engineering, Turkey*

### Abstract

One of the most important properties of flexible pavements is the surface texture. The texture of the pavement surface and its ability to resist the polishing effect of traffic is of prime importance in providing skidding resistance. Pavement surface macrotexture greatly contributes to tire–pavement skid resistance which has a direct effect on traffic operation and safety particularly at high speeds. Doubtless, there exists a close relationship between the surface texture and the angularity characteristics of the aggregates within the pavement system.

This paper describes the evaluation of the angularity characteristics of the aggregates crushed with different types of crushers, and their impact on the surface properties of the pavements such as texture and surface friction. For this purpose, limestone aggregates were prepared using impact, jaw, and roll crushers. Following the determination of the angularity characteristics of the aggregate using ASTM C1252 involving two different test methods (Methods A and B) and the EN 933-6, the asphalt slabs (65x65 cm) have been prepared and compacted at their optimum bitumen contents. Texture properties of the slabs have been studied using sand patch method and laser scanner. The frictional properties have been also determined by means of Dynamic Friction Tester (DFT). Finally, evaluations have been made to determine the relationship of aggregate angularity and the surface properties.

*Keywords: aggregate angularity, skid resistance, surface friction, crushers, dynamic friction tester, laser scanner*

### 1 Introduction

With continuous growth in amount of highway traffic and capacity, traffic crashes increase annually over the whole world. Along this increase, a great demand and focus on the needs for safer roads and highways become prior in road projects. Pavement surface friction is a key factor influencing wet–pavement accidents and, consequently, road safety [1]. Wilson and Dunn (2005) classified the factors that affect pavement skid resistance into four chief groups: road surface and aggregate factors, vehicle factors, load factors and environmental factors [2]. Among these Categories, road authorities can develop material and construction specifications that influence the second category (road surface and aggregate), which influences the microtexture and macrotexture of an asphalt pavement surface [3]. Microtexture is defined as pavement surface deviation from a planar surface in the range of less than 0.5 mm in height and typical peak–peak amplitude less than 0.2 mm and is responsible for maintaining the contact between the pavement surface and the tire [4].

Microtexture is primarily influenced by aggregate particle mineralogy, which affects the initial texture of the aggregate surface and the ability of the aggregate to retain its texture against the polishing action of traffic and environmental factors. Macrotexture is defined as pave-



ment surface deviation from a planar surface in the range of 0.5 to 50 mm in height and typical peak–peak amplitude 0.2–10 mm. Pavement macrotexture is primarily influenced by the size, shape, and gradation of coarse aggregates; the nominal maximum aggregate size (NMAS), and construction techniques. Macrotexture influences skid resistance by controlling the paths available for water to escape so that it does not accumulate between the tire and the pavement surface, and by changing the tire tread rubber deformation. Bond showed how differences on microtexture and macrotexture of pavement surfaces influence peak brake coefficients of a standard test tire [5].



**Figure 1** Pavement surface characteristics classification and their impact on pavement performance measurements

The primary indexes used to characterize the texture with the above mentioned techniques are the mean texture depth (MTD) and the mean profile depth (MPD).

## 2 Experimental

### 2.1 Materials

#### 2.1.1 Bitumen

The bitumen with a 50/70 penetration grade was procured from Aliaga/Izmir Oil Terminal of the Turkish Petroleum Refinery Corporation. In order to characterize the properties of the base bitumen, conventional test methods such as: penetration test, softening point test, ductility, and test were performed. These tests were conducted in conformity with the relevant test methods that are presented in Table 1.

#### 2.1.2 Aggregate

Natural Limestone ballasts were procured from Dere Beton/Izmir quarry. ballast particles were crushed with different crushers to obtain particle sizes as specified in gradation. Grading of aggregate was chosen in conformity with the Type 2 wearing course of Turkish Specifications. The results of aggregate properties are presented in Table 2.

The ASTM C1252 'Uncompacted Void Content of Fine Aggregate' was used to determine the uncompacted unit weights of the fine aggregates. This method estimates the angularity, sphericity and surface texture of the aggregate having a given grading. There are two methods for running this test: Methods A and B. The mass of the sample for both methods is fixed at 190 g. Method A specifies a standard gradation ranging from 8# (2.36mm) sieve to 100# (0.15mm). Method B specifies that the test be run on the three individual size fractions (B1, B2, B3); 8–16# (2.36–1.18mm), 16–30# (1.18–0.6mm) and 30–50# (0.6–0.3mm).

**Table 1** Results of the experiments conducted on asphalt cement

Test	Specification	Results	Specification limits
Penetration (250 °C; 0.1 mm)	ASTM D5 EN 1426	55	50–70
Softening point (°C)	ASTM D36 EN 1427	49.1	46–54
Viscosity at (135°C)-Pa.s	ASTM D4402	0.338	-
TFOT (163 °C; 5h)	ASTM D1754 EN 12607-1		
Change of mass (%)		0.04	0.5 (max)
Retained penetration (%)	ASTM D5 EN 1426	51	50 (min)
Ductility (25°C)-cm	ASTM D113	100	-
Specific gravity	ASTM D70	1.030	-
Flash point (°C)	ASTM D92 EN 22592	+260	230 (min)

Also another standard method, which is similar to ASTM C1252, has been existed for coarse aggregates. Modified ASTM C1252 'Determining the Percent of Solids and Voids in Coarse Aggregate' (AASHTO TP 56) was used to determine the angularity, sphericity and surface texture of the coarse aggregate. The mass needed to perform the test is 5000g. Method A specifies a standard gradation ranging from 19mm sieve to 4.75mm. Method B specifies that the test be run on the three individual size fractions (B1, B2, B3); 19mm–12.5mm, 12.5mm–9.5mm and 9.5mm–4.75mm [6]. The EN 933-6 'Geometrical Properties of Aggregates Assessments of Surface Characteristics, Flow Coefficient of Aggregates' test method was used to determine the flow coefficient of aggregates. As seen in table 3, the flow coefficients related to 10–200# yield higher values (which means higher angularity) compared to 5–200# which demonstrates the effect of gradation on the flow coefficients of the samples [7].

Table 3 presents the evaluation of the angularity between aggregates prepared with different crushers.

**Table 2** The properties of limestone aggregate

Test	Specification	Result	Specification limits
Specific gravity (coarse aggregate)	ASTM C 127	2.653	-
Specific gravity (fine aggregate)	ASTM C 128	2.663	-
Los Angeles abrasion (%)	ASTM C 131	24.4	Max 30
Sodium sulphate soundness (%)	ASTM C 88	1.47	Max 10-20

**Table 3** Uncompacted void content and flow coefficient of aggregates

Aggregate type	Uncompacted void content on standard graded sample, % (ASTM C1252)				Flow coefficient, s (EN 933-6)	
	Fine aggregates		Coarse aggregates		5-200#	10-200#
	Method A	Method B	Method A	Method B		
IA	43	46	42	43	26.71	38.25
JA	41	42	41	43	25.6	37.96
RA	39	41	38	40	20.58	34.18

IA, JA, RA, aggregate samples which were prepared with Impact, Jaw and roll crusher.

## 2.2 Crushers

Crushing is the process of reducing the dimension of rocks to desired values. Crushing reduces the size of the rock particles to make them suitable for use in mixtures [8]. Crushing also changes the texture and shape of particles.

In this study, aggregates were prepared using 3 different crusher.

- Impact crusher: In this class crusher comminution is by impact rather than compression by sharp blows applied at high speed to free-falling rock.
- Jaw crusher: The distinctive feature of this class of crusher is the two plates which open and shut like animal jaws. The jaws are set at an acute angle to each other, and one jaw is pivoted so that it swings relative to the other fixed jaw.
- Roll crusher: Roll crusher, or crushing rolls, are still used in some mills, although they have been replaced in many installations by cone crushers.

## 2.3 Preparation of asphalt slabs

A limestone aggregate was used in all the Hot mix asphalt (HMA) mixes for this investigation. Aggregates crushed with different crushers and blended in batches to provide the design gradation. For each of the batches the design optimum asphalt content was found as 4.65%, 4.60% and 4.60% for I1, J1 and R1 respectively. The HMA mix weight was calculated to produce a slab 2 inches thick. Each batch of aggregate was split and placed in two buckets for heating. The asphalt cement was weighed placed in a beakers can for heating. The two steel buckets of aggregate to make up the total batch were placed in a 170°C oven overnight. This temperature and time was chosen to assure a constant temperature throughout the aggregate before mixing. After mixing aggregates with bitumen in mixer, The HMA was immediately placed in the center area of mold. The HMA was then pushed out to the corners and smoothed out using trowel. Specimens were compacted using the walk-behind roller at their compaction temperature. Each sample was 26 inches (650mm) in side and approximately 2 inches (50mm) in thick.

## 2.4 Test methods

There are many methods developed to measure Macro and skid resistance properties of a pavement so far [9]. Methods and the associated tests used in this study are mostly based on ASTM standards. These methods are accordingly Sand patch method [10] to measure mean texture depth (MTD), a recent and more reliable method of laser Scanner [11] to obtain mean profile depth (MPD) values and Dynamic Friction Tester [12] which is used to measure the friction coefficient of a surface at a regular speed (0 – 90 Km/hr).

### 2.4.1 Sand patch

The volumetric, or sand patch method (ASTM E 965, 2006), has been historically used as the main technique for measuring pavement macrotexture. The texture depth of the surface on

which the sand patch test is performed, is represented by MTD. 25 mm<sup>3</sup> of fine glass beads (75µm in dimensions) are spread on a circular area over a cleaned surface measuring the average diameter of the resulting circle. MTD values are then calculated using the equation (1).

$$MTD = \frac{40xV}{\pi x D^2} \tag{1}$$

Where v is volume of glass beads in mm<sup>3</sup> and D is average diameter of the circles in mm.

### 2.4.2 3D LASER Scanning test

3D laser Scanning test is used to scan surface macrotexture profiles of the pavement surfaces. Data collecting system includes a LASER scanner and a built-in USB output to transfer scanned data to the portable computer to execute additional processing by software package which accompanies the device to give out Mean Profile Depth (MPD) values as the conflicts between the peak and mean elevations for sequential sections. The 3D laser scanner with enhanced sensor performance introduced in this study inspected full range of colors and depths on asphalt pavement surfaces. The MPD values are computed from a sample baseline divided into two equal halves as presented in Figure 2 left. The peak level in each half is determined and the average of the two peaks is termed the MPD value.

### 2.4.3 Dynamic Friction Tester

The pavement surface texture and skid resistance was measured in each polished location at different polishing intervals using the dynamic friction tester (DFT), respectively. The DFT device (Figure 2 right) consists of three rubber sliders attached to a rotating disk driven by a motor that can reach up to 80 km/h tangential speed. While the device drags on the pavement surface, the coefficient of friction of the surface is determined by measuring the traction force in each rubber slider.

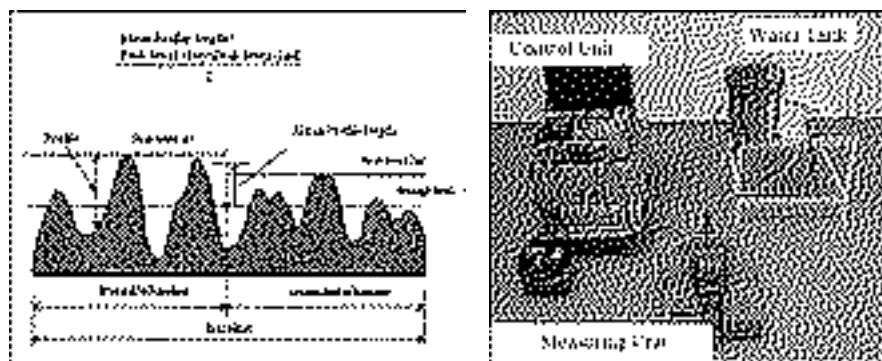

Figure 2 Method for MPD Calculation (left) and DFT Tester Units (right)

## 3 Results and discussions

### 3.1 MTD and (MPD)

The variation of MTD and MPD values are presented in table 4. IP, JP, RP pavement samples which were prepared with IA, JA and RA aggregates. As presented in table 4, the MTD and MPD values of sample J1 (which is crushed with jaw crusher) is greater than other specimens.

**Table 4** MTD and MPD values

Specimen type	MTD (mm)	MPD (mm)
IP	0.852	0.546
JP	0.872	0.685
RP	0.767	0.494

### 3.2 DFT(20) values

An additional analysis was done to compare the DFT (20) values. DFT (20) values are used as standard values for friction coefficients recently. Table 5 shown values of this comparison.

**Table 5** DFT(20) values

Specimen type	DFT(20)
IP	0.317
JP	0.384
RP	0.281

As given in table 5 specimens which prepared with jaw crusher (J1) have respectively high DFT (20) values.

## 4 Conclusions

Aggregate particle shape, size and gradation have an impact on the performance of asphaltic mixtures. In asphaltic mixtures, the shape of aggregate particles is related to surface texture and skid resistance of pavements. In summary, the results of the research indicate that it is possible to control and predict frictional properties of the pavement by selecting the crusher type. Crushers can change the aggregate angularity and shape and it is directly affects the skid resistance of HMA. The influence of the aggregate type on asphalt concrete skid resistance was investigated through preparing and testing laboratory slabs.

R1 sample (the sample which was prepared with roll crusher) has the lowest angularity values between all samples and also has the lowest DF (20), MPD and MTD values. The results of the friction measurements by the DFT device showed that the J1 sample (the sample which was prepared with jaw crusher) had higher DFT (20) values than the other samples. Also it has the greatest MPD and MTD values. Consequently this type of crusher can be preferred as a secure type of crusher in terms of skid resistance. The fact proves the compatibility between MTD and MPD values.

The results of the analysis confirmed the strong relationship between mix frictional properties and aggregate properties.

## References

- [1] Masad, E., Rezaei, A., Chowdhury, A., and Harris, P. (2009): Predicting asphalt mixture skid resistance based on aggregate characteristics. FHWA/TX-09/o 5627-1, Texas Transportation Institute, College Station, TX.
- [2] Wilson, D. J., and Dunn, R. C. M. (2005): Analyzing road pavement skid resistance. Australian Road Research Board (ARRB) Int. Conf. Institute of Transportation Engineers, Melbourne, Australia.
- [3] Rezaei, A., Masad, E., Chowdhury, A. (2011): Development of a Model for Asphalt Pavement Skid Resistance Based on Aggregate Characteristics and Gradation.
- [4] Hall, J. W., et al. (2006). Guide for pavement friction. Project No. 1-43, Final Guide, National Cooperative Highway Research Program, Transportation Research Board, Washington, DC.
- [5] Bond, R., Katekhda, I.E.D., Lees, G., and Williams, A.R. 1976. Tire/Road Surface Interaction. Journal of the Institution of Highway Engineers, November.
- [6] Masad, E., Al-Rousan, T., Button, J., Little, D., and Tutumluer, E. (2005): Test methods for characterizing aggregate shape, texture and angularity. NCHRP 4-30A Final Rep., No. 555, National Cooperative Highway Research Program, National Research Council, Washington, DC.
- [7] EN 933-6, European Standard Tests for Geometrical Properties of Aggregates, Part 6, Assessments of Surface Characteristics, Flow Coefficient of Aggregates, 2001.
- [8] Topal, a. (2008): Development of new digital image analysis methods for determination of the geometrical properties of aggregates. PhD's thesis, Dokuz Eylul univ., Izmir, Turkey.
- [9] NCHRP guide for pavement friction
- [10] ASTM, Standard Test Method for Measuring Pavement Surface Frictional Properties Using the Dynamic Friction Tester, ASTM E 1911-98, Volume 04.03, ASTM, West Conshohocken, Pennsylvania (1999).
- [11] ASTM, Standard Practice for Calculating Pavement Macro-Texture Mean Profile Depth, ASTM E 1845-01, Volume 04.03, ASTM, West Conshohocken, Pennsylvania (2003).
- [12] ASTM, Standard Test Method for Measuring Pavement Macro-Texture Depth Using a Volumetric Technique, ASTM E 965-96, Volume 04.03, West Conshohocken, Pennsylvania (1998).



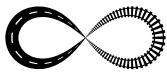

## COMPARISON OF LOW-TEMPERATURE BITUMINOUS MIXTURES SELECTED PROPERTIES

Josef Zak<sup>1</sup>, Jiri Vavricka<sup>1</sup>, Silvia Stefunkova<sup>2</sup>

*1 Czech Technical University in Prague, Faculty of Civil Engineering,  
Department of Road Structures, Czech Republic*

*2 Slovak University of Technology in Bratislava, Faculty of Civil Engineering,  
Department of Transportation Engineering, Slovakia*

### Abstract

Nowadays the theme of reducing energy needs for bituminous mixtures production is topical. In this case is one of the solutions to use low temperature bituminous mixtures. This modern technology ensures the similar or higher quality parameters in one hand with lower processing temperature, compared to conventional mixtures produced by the hot process. This article is based on controlled study approach and deals with properties experimental verification of low temperature bituminous mixtures focusing on fatigue, crack propagation, Young's modulus and complex modulus.

*Keywords: low temperature asphalt mixtures, Young's modulus,  
complex modulus, fatigue, crack propagation*

### 1 Introduction

The theme of reducing energy needs for bituminous mixtures production is very topical. In this case is one of the solutions to use low temperature bituminous mixtures. Technology of these mixtures is divided into the technology of adding organic additives and waxes or chemical additives and reagents. Other possibility is foamed asphalt. The function of additives is based on lowering asphalt viscosity and can be add into asphalt binder or bituminous mixtures. The lower viscosity enable to lower temperature needs for production and processing. The level of reducing temperature depends on the additive type. The asphalt binder modification with low-viscosity additive improves its properties. For low temperature bituminous mixtures is an advantage ensuring equal or higher quality parameters as well at lower temperatures, compared to conventional mixtures produced by the hot process. Generally can be concluded increase the resistance of bituminous mixtures to traffic loads, increase bearability and extend the life time of which implies improve road safety.

### 2 Properties experimental verification

In the experimental part were designed specific types of asphalt mixtures specifically asphalt concrete (ACL 16, ACP 16 and ACP 22 in accordance with [9]) with the binder 50/70 modified by FT additive (organic intermixture) and as well modified by IT additive (chemical intermixture). The asphalt mixtures with binder without additives were chosen as a reference. An experimental properties verification of the strength and deformation characteristics of the asphalt mixtures was carried out tests for resistance to fatigue, crack propagation, a determination of Young's modulus and Complex modulus of asphalt mixtures. From the test results evaluation



can assess the impact of the additives on the durability asphalt mixture against the applied load and assess the appropriateness of the use of additives for a particular asphalt mixtures.

### 3 Young's modulus

Values of the Young's modulus characterize the resistance of asphalt mixtures to the applied load, depending on the stress and strain. With the Young's modulus increase decrease the asphalt mixture strain and increase the resistance against the traffic load. The test could be processed by several test methods on different test specimens. In the study was used IT-CY method (indirect tensile test) using a cylindrical specimen with dimensions of 101.6 x 62.5 mm according to [4] and [7]. Test temperatures were chosen 0, 15, 27 and 40 ° c. With the temperature increase the value of asphalt mixture Young's modulus decrease. As can be seen from values mentioned table subsequently use of FT additives results in an increased Young's modulus which contribute to better resistance against load. The percentage increase at 0°C is 6.5% at 15°C 18% at 27°C 30% and at 40°C 35% (compared with reference asphalt mixture).

**Table 1** Table 1. Young's modulus (IT-CY method):

Bituminous mixture	Temperature [°C]	S <sub>m</sub> [MPa]	Increase S <sub>m</sub> [%]
ACP 22 50/70	0	21499	0
ACP 22 50/70 + 3% FT		22894	6,5
ACP 22 50/70	15	9318	0
ACP 22 50/70 + 3% FT		10978	17,8
ACP 22 50/70	27	3049	0
ACP 22 50/70 + 3% FT		3957	29,8
ACP 22 50/70	40	865	0
ACP 22 50/70 + 3% FT		1167	34,9

### 4 Complex modulus

Part of the research project was focused on asphalt mixture complex modulus comparison. Measurement of complex modulus was chosen because it is a viscoelastic characteristic and therefore reflects time aspect of load.

Measurements were made by 4PB-PR method according to [4] and [7] in the temperature range from -10°C to 40°C and a frequency range 0.1 ~ 60Hz. These measurements were then with the help of Time–Temperature Superposition (TTS) principle [2] shifted into one master curve. To achieve a comprehensive quality of the master curve in the frequency range was chosen logarithmically growing range of frequencies. Applying the TTS principle was obtained information on the material characteristics of the larger interval of frequency than which could be ever measured with test equipment [1]. The reference temperature was chosen to 30°C. Comparison of real and imaginary components of complex modules and phase angles are shown in Fig. 1 and Fig. 2.

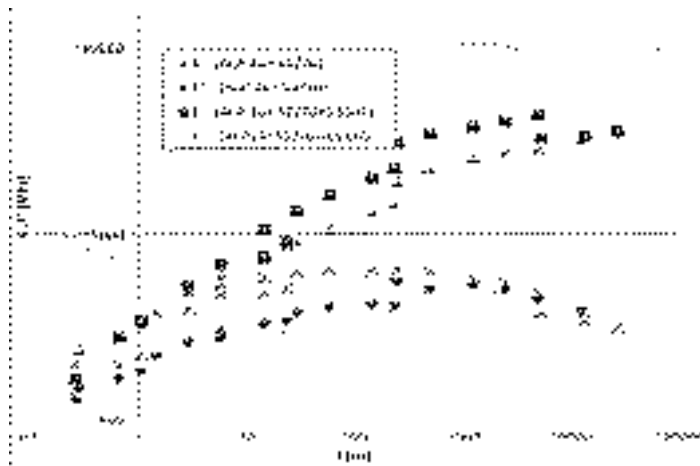

Figure 1 Real and imaginary part of complex modulus

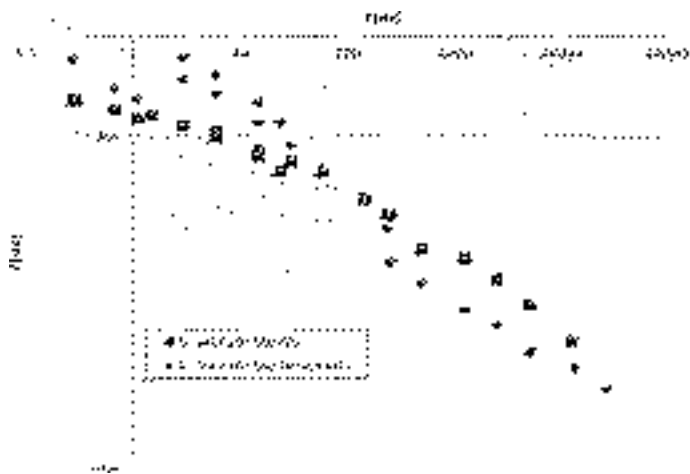

Figure 2 Phase angle

From these results it can be concluded some differences between regular asphalt mixture ACP16+ 50/70 and ACP16+ 50/760 with  $\pi T$  additive. Asphalt mixtures with addition of  $\pi T$  have a considerably higher value of real and imaginary components of complex modules in the middle frequency range. If we consider the chosen reference temperature of  $30^\circ \text{C}$  as the temperature of pavement, this difference should result in a smaller deformation caused by vehicles at common speed. In this area of frequency have the asphalt mixtures similar values of phase angle, this property indicates that the same part of the deformation in the material remains preserved as plastic deformation.

Complex modules in the lower and higher frequency range are comparable for both mixtures. The phase angle of asphalt mixtures without the addition has a lower value in the lower frequency range and higher values in the higher frequency domain. Mixture with the addition of  $\pi T$  is likely to have higher initial deformation (consequent compaction of asphalt mixture) and a lower increase in permanent deformation (in the form of rutting) over a lifetime.

## 5 Fatigue

The fatigue test method defines asphalt mixture resistance against cycling load. The test specimens are exposed to repetitive compression stress causing a fracture in the perpendicular plane.

**Table 2** Table 2. Fatigue characteristics

Asphalt mixture	T [°C]	$\delta x$ [kPa]	Sm [MPa]	$\delta$ [ $\delta$ strain]	Fatigue characteristics		
					k	n	$\delta$ [ $\delta$ strain]
ACP 22 50/70	15	800	9318	0,16570	75,512	1,635	0,17271
		900		0,18641			0,17076
		1000		0,20713			0,21695
ACP 22 50/70 + 3% FT	15	800	10978	0,14065	0,291	4,7681	0,14204
		900		0,15823			0,15496
		1000		0,17581			0,17776

Test according to [3] and [6] can be implemented on different test specimens. In this article are presented values measured on cylindrical specimens with dimensions of 101.6 x 40 mm. During the test is measured vertical deformation of the specimen until failure. Then is determining the tensile strain in the middle of specimen and based on the relation of strain and number of load cycles is computed fatigue life. Mentioned dependence is expressed in logarithmic scale using the S-N curve also known as Wöhler's diagram (Fig. 3), where the slope of the S-N curve refers to fatigue life of the asphalt mixture. When the derivation of the S-N curve is higher than the material has better resistance to fatigue. Experimental properties of asphalt mixtures ACP 22 have been verified. Adding FT additives into binder leads to extend the lifetime of the asphalt mixture and increase its resistance to the applied load.

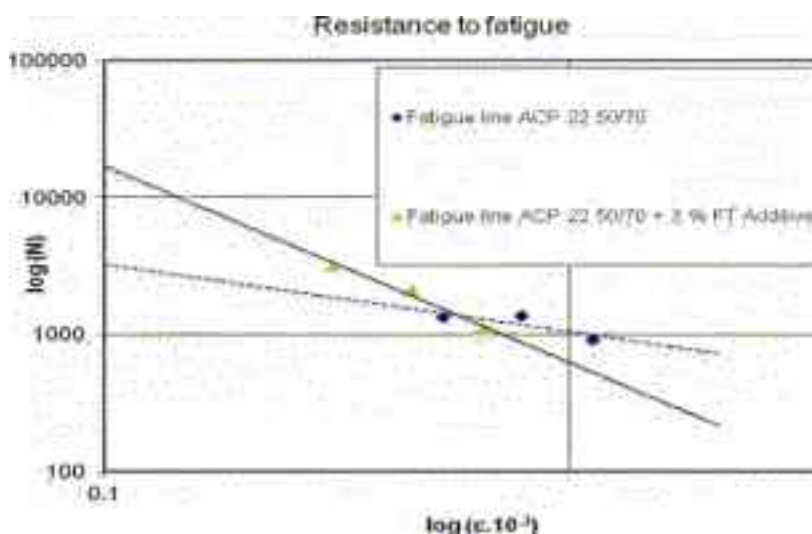

**Figure 3** Resistance to fatigue of the asphalt mixtures

## 6 Crack propagation

Resistance of asphalt mixtures to crack propagation is determined on the half-cylindrical specimen with the groove in the middle Fig. 4. The specimen is loaded by bending in three points. Bend specimen is than caused by a constant increment of deformation (5 mm per minute). The load is continuously increased to a peak value of  $F_{max}$ , which directly relates to the resistance to fracture of the specimen  $K_{Ic}$ . In our case we used half-cylindrical specimens with a diameter of 101.6 mm and 50 mm thick. The test temperature was chosen 5°C. Adding ingredients IT (IterFlow) was increased resistance to asphalt crack propagation as can be seen from table:

**Table 3** Table 3. Asphalt mixture crack propagation resistance:

Asphalt mixture	$\epsilon_{max}$ [%]	$F_{max}$ kN]	$K_{Ic}$ [N/mm <sup>3/2</sup> ]	Increase of $K_{Ic}$ [%]
ACP 16+ 50/70	1,86	5,70	37,11	0
ACP 16+ 50/70 + 0,5 % IT	1,66	6,05	39,34	6,0

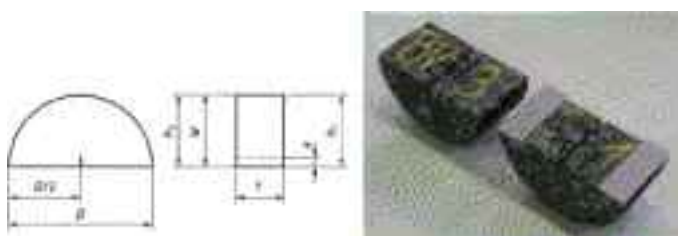

**Figure 4** Half-cylindrical specimen

## 7 Conclusion

The positive influence of used additives (which lowers production temperature and lay down temperature) was proved by several test procedures. With the modification of asphalt binder by IT and FT can be achieved better properties of asphalt binder and asphalt mixes. In the article were taken in consideration Asphalt mixes used in asphalt base layers and their properties with respect to Young's modulus, Complex modulus, Fatigue and Crack propagation were taken in consideration in this article. The additives has better influence to asphalt mixes stiffness (Higher value of Young's modulus and Complex Modulus), also resistance against cycling load (fatigue) and crack propagation. With the achieving desired, respectively increasing the quality parameters of asphalt mixes with one hand with choice of appropriate technological processes and other important factors affecting the asphalt mixes production and further performance, we can ensure a safer, more convenient and economical driving a motor vehicle.

## Acknowledgements

The article was supported by the project VEGA 1/0401/10 'Energy saving, economical and environmentally roads and traffic platforms'.

The research reported in this article was funded by SGS11/036/OHK1/1T/11 and GA103/09/0335 'Rheology and experimental determination of functional characteristics of warm asphalt mixes'.

## References

- [1] Ferry J.D.; *Viscoelastic Properties of Polymers* 3rd edition; University of Wisconsin; 1980
- [2] Dealy J. M., Wissbrun K.F.; *Melt rheology and its role in plastic processing Theory and application*; Kluwer Academic Publishers; 1999
- [3] ČSN EN 12697-24+A1 (736160) Bituminous mixtures – Test methods for hot mix asphalt - Part 24: Resistance to fatigue
- [4] ČSN-EN 12697-26; Bituminous mixtures – Test methods for hot mix asphalt - Part 26: Stiffness; 2006
- [5] ČSN EN 12697-44 Bituminous mixtures – Test methods for hot mix asphalt – Part 44: Crack propagation by semi-circular bending test, 2011
- [6] STN EN 12697-24 + A1 Bituminous mixtures – Test methods for hot mix asphalt - Part 24: Resistance to fatigue, 2008 (consolidated text)
- [7] STN EN 12697-26 Bituminous mixtures – Test methods for hot mix asphalt - Part 26: Stiffness; 2010
- [8] STN EN 12697-44 (736160) Bituminous mixtures – Test methods for hot mix asphalt – Part 44: Crack propagation by semi-circular bending test, 2011
- [9] CSN EN 13108-1, Bituminous mixtures-Material specifications-Part 1: Asphalt Concrete

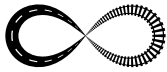

## RESEARCH OF ASPHALT LAYERS BONDING IN LITHUANIAN PAVEMENT

Audrius Vaitkus<sup>1</sup>, Donatas Čygas<sup>2</sup>, Alfredas Laurinavičius<sup>2</sup>,  
Viktoras Vorobjovas<sup>1</sup>, Rita Kleizienė<sup>1</sup>

*1 Roads Research Institute, Vilnius Gediminas Technical University, Lithuania*

*2 Dept of Roads, Vilnius Gediminas Technical University, Lithuania*

### Abstract

The bonding of asphalt layers has direct reliance on road pavement structures strength and durability. Because of insufficient bond of pavement layers the slippage and tearing, rutting and cracking emerge and the pavement life cycle becomes shorter. The article describes the research, which was made in 2010-2011 at Vilnius Gediminas Technical University Road Research Institute. In this research the strength of layers bonding was assessed using direct shear (Leutner) test, without normal stress in specimen. The samples were chosen from road sectors in Lithuania with standard asphalt layers, also asphalt layers with geosynthetics interlayer.

*Keywords: asphalt layers bonding, bonding strength, Leutner test, asphalt pavement*

### 1 Introduction

The bonding of asphalt layers is a significant factor which directly influences the strength and durability of pavement. The bonding of asphalt layers is influenced by the size of aggregates of asphalt mix, type of asphalt mix and binder, type and amount of bitumen emulsion, as well as the type of construction technology [1], [2]. Due to insufficient bonding between asphalt layers the upper asphalt layer under the effect of shear force can slip in parallel to the asphalt binder layer, and the asphalt binder layer can slip in parallel of asphalt base layer. In that case, corrugation, slippage and transverse cracking occur in the asphalt pavement structure. The pavement distress usually occurs in acceleration/deceleration and turning zones. Because of insufficient bonding of the asphalt layers, the asphalt pavement life cycle become shorter. Sufficient bonding of the asphalt layers assures the necessary bearing capacity, strength, and durability of pavement structure [1], [2]. Sufficient bonding assures that all asphalt layers in pavement work as a monolithic structure, and the largest stress from wheel loads is concentrated at the bottom of asphalt base layer. In that case cracking starts from asphalt base course also. When the bonding is insufficient each asphalt layer operates separately and the maximum stress concentrates in the bottom of each asphalt layer.

The bonding between asphalt layers is conditioned by friction and interlocking of layers. The friction is reduced by an over-large amount of binder between the layers, when is formed a binder coat, which doesn't allow to contact of separate asphalt layers. The bonding between asphalt layers depends on friction, bonding and interlocking of the layers. There are three types of asphalt layers bonding [3]:

- Sufficiently bonded –asphalt layers work as a monolithic structure. A large shear stress occurs and no deformations (displacement) are developed. However, this is a theoretical model, because in practice the bonding plane of asphalt layers is always represented by smaller or larger deformation.

- Partially bonded – depends on the strength of interlocking the shear stress and deformations (displacements) of various sizes occurs between layers. In case of strong interlocking occurs large shear stress and small deformation. In case of weak - occurs small shear stress and large deformation.
- Insufficiently bonded – friction and bonding occur only due to the load and the self-weight of layers. Small shear stresses and large deformations occurs between the layers.

K. Schulze [4] obtains that insufficient bonding between asphalt layers can cause corrugation and rutting of pavement. R. Weber [5] stated that cracks in asphalt pavement occur because of insufficient bonding of asphalt layers. J. Eisenmann and U. Neumann[6] reported that optimal bonding is necessary to guarantee asphalt pavement strength to prevent rutting. G. King and R. May [7] determined that deformation in the asphalt pavement layers significantly increases with decrease of layer bonding from 100% to 90%, and results in early asphalt pavement deterioration. C. J. Roffe and F. Chaignon [8] stated that the life cycle of asphalt pavement can decrease by seven or eight years without sufficient asphalt layer bonding. R. Dübner and W. Glet [9] said that insufficient bonding between layers can influence deformation and crumbling on the pavement. L. Tashman and others [10] stated that the asphalt layers bonding strength depend on the surface preparation, the amount of sprayed binder emulsion, the time interval between spraying of binder emulsion and another asphalt layer construction. In 2011, A. Vaitkus et al. [11] declared that there was no difference detected of the asphalt layers bonding strength depending on the sampling location – in the wheel-path or in-between the wheel-path of the same road. The reliance of stress and deformation distribution in pavement construction from transportation overload and climate effects was tested in a specially constructed testing road [12], [13].

## 2 Determination of asphalt layers bonding strength

The asphalt interlayer bonding strength can be determined by the various methods. Usually is used the Shearing test, less often the Pull-off and Torque tests (Figure 1). Mostly are used Shearing test in order to evaluate the bonding strength between the layers of asphalt. The shearing test can be performed without normal stress (direct shear test) and with normal stress (simple shear test):

- 1 The Direct shear test: the Leutner test, the Parallel-Layer Direct Shear test, the LBC test, the De Bondt test, the U.S. National Asphalt Technology Center Shearing test (NCAT), the FDOT test, the Iowa test, the Rommanoshi test, the Al-Qadi test, the Asher test, and the SST- Superpave Shear Tester.
- 2 The Simple shear test: the MCS trial, the ASTRA trial, and the SST trial.

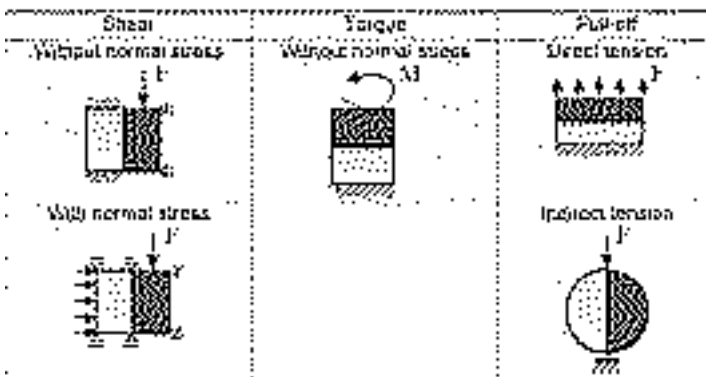

**Figure 1** Asphalt layer bonding determination methods [3]

In 1979, R. Leutner described the method of direct shear test for determining the asphalt layer bonding strength [14]. The Leutner test is one of the most commonly used direct shear method. It is used in many countries in Switzerland, Austria, and Germany it has been accepted as the national standard for evaluating asphalt layer strength. The bonding of layers is evaluated according to the measured maximum shear force (kN) and shear flow (mm).

In Germany, the bonding strength of asphalt layers is determined by performing the Leutner test according to the document TP asphalt–StB Teil 80 (Direct shear test). In Germany the minimum value of the asphalt layer bonding strength regulated by the document ZTV Asphalt–StB 07[15]: between the asphalt wearing and binder layers – not less than 15 kN; between all other asphalt layers – not less than 12 kN. The recommended limit values between wearing-binder asphalt layers is 2,0–4,0 mm and between binder-base 1,5–3,0 mm for the shear flow are given in ZTV M–V and Arbit Nr. 60.

### 3 Experimental research

The experimental research was performed in laboratory of Road Research Institute of the Vilnius Gediminas Technical University in 2010 and 2011. The Direct shear tests were performed on samples prepared in laboratory and on samples (cores) taken from Lithuanian roads and city streets.

#### 3.1 Results from samples made in laboratory

In the laboratory the samples of asphalt wearing and binder layers were prepared with different type and the amount of bitumen emulsion between the layers and different compaction degree of the asphalt wearing layer. The roller compactor was used to compact the samples. The wearing layer was made from AC 11 VN and AC 11 VS hot mix asphalt, and the binder layer – AC 16 AN.

Different types and quantity of bitumen emulsion were sprayed in between the asphalt layers. The emulsion's working temperature was 40°C. For comparison, there were also made asphalt layers slabs without the bitumen emulsion in between the layers. The compaction degree of the asphalt wearing layer was 97% or 100%, and the asphalt binder layer - 97% in all samples. From the each asphalt slab, that had been made, was drilled three 150 mm diameter asphalt cores. The interlayer bonding was measured by the Asphalt technical testing guidelines, Part 80. (German-Technische Prüfvorschriften für asphalt, TP Asphalt–StB Teil 80). The tests were performed in standard Marshall press with shearing form. It was used constant speed static load of 50 mm/min. Before the test, asphalt cores were stored at 20°C temperature for 24 hours. The combinations of samples made in laboratory and the test results are presented in Table 1.

The test results (Fig. 2) showed that the shear force vary in a wide interval, from 14,2 kN to 44,8 kN. The minimum shear force was in combination No. 3 and 4, the samples in which asphalt wearing layer was AC 11 VS with 97% and 100% compaction degree, and no any bonding material were used in interlayer. The maximum shear force was in combination No. 9 (38,17 kN after 2 days and 43,83 kN after 10 days), the samples in which asphalt wearing layer was AC 11 VN with 97% compaction degree, and 150 g/m<sup>2</sup> bitumen emulsion in interlayer. Dependent on test performance time the 13% greater shear force was obtained after 10 days. The shear force results of samples with 100% compaction of asphalt wearing layer was 13% (AC 11 VN) and 18% (AC 11 VS) higher comparing with 97% compaction degree. All tested samples, which asphalt wearing layer was from the AC 11 VN, was determined greater value of av. 26% (tested after 2 days) and av. 54% (tested after 10 days) comparing with values of asphalt wearing layer made from the AC 11 VS. In this case the bitumen emulsion wasn't use in the interlayer.



**Table 1** The combinations of samples made in laboratory and the test results

Testing combination	Interlayer bonding material	The quantity of bonding material [g/m <sup>2</sup> ]	The mix of asphalt wearing layer (compression degree [%])	The mix of asphalt binder layer (compression degree [%])	Shear force [kN]		Shear flow [mm]	
					After 2 days	After 10 days	After 2 days	After 10 days
1	-	-	AC 11 VN (97%)	AC 16 AN (97%)	21,67	36,73	1,93	2,80
2	-	-	AC 11 VN (100%)		21,97	41,50	2,93	1,73
3	-	-	AC 11 VS (97%)		14,23	28,27	2,33	1,70
4	-	-	AC 11 VS (100%)		14,30	33,53	1,90	1,87
5	C 60 BF 1-S	90	AC 11 VN (97%)		30,00	44,77	3,10	3,47
6	C 60 BF 1-S	135	AC 11 VN (97%)		22,83	42,50	2,10	2,57
7	C 60 BF 1-S	200	AC 11 VN (97%)		32,73	32,73	2,27	2,27
8	C 60 BP 1-S	100	AC 11 VN (97%)		33,25	36,67	2,81	3,46
9	C 60 BP 1-S	150	AC 11 VN (97%)		38,17	43,83	3,16	3,00
10	C 60 BP 1-S	250	AC 11 VN (97%)		35,83	38,42	3,33	4,44

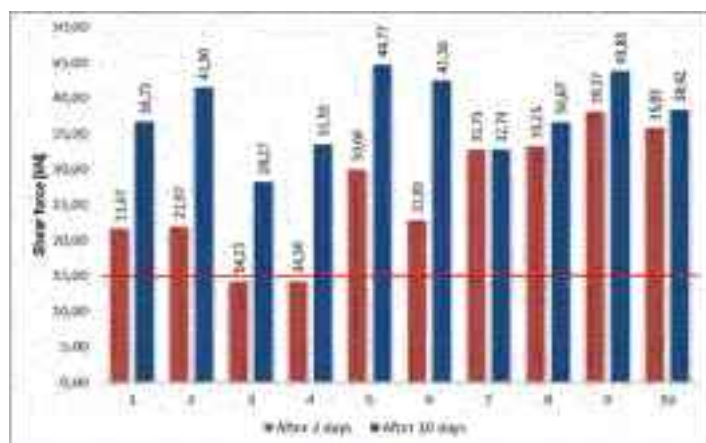

**Figure 2** The distribution of shear force between the asphalt wearing and binder layers in samples prepared in laboratory. — the line shows the lowest allowable limit of bonding strength between the asphalt wearing and binder layers

The bonding strength was about 30% greater with bitumen emulsion c 60 BF 1-S in asphalt interlayer than without (tested after 2 days) and no significant difference tested after 10 days. A significant difference of bonding was defined on comparing the samples tested after 2 and 10 days where the bitumen emulsion wasn't used in the interlayers. In this case, the difference

of bonding strength was in range from 69% to 134%, depending on the type of asphalt mix used on the wearing layer, and the degree of compaction. It was obtained that the shear force is much higher in samples with bitumen emulsion c 60 BP 1–S than samples with bitumen emulsion c 60 BF 1–S. The difference in results 2 days after compaction varies from 10% to 60%, but no significant difference obtained in samples tested 10 days after compaction. It was determined that the asphalt layer shear flow values changed from 1.7 mm to 4.5 mm. The samples with bitumen emulsion c 60 BF 1–S shear flow varied from 2.1 mm to 3.5 mm. The greatest values determined in the samples with 90 g/m<sup>2</sup> emulsion, tested after 10 days. The samples with bitumen emulsion c 60 BP 1–S shear flow varied from 2.8 mm to 4.5 mm. The greatest value was determined in the samples with 250 g/m<sup>2</sup> emulsion, tested after 10 days. The analysis of the asphalt layer bonding strength results shows that after 10 days of asphalt compaction, the bonding strength in all cases was greater than 25 kN and the shear flow was greater than 1.5 mm. It should be stated that the use of bitumen emulsion leads to sufficient bonding of asphalt layers, but only right amount of bitumen emulsion ensures the good bonding and the allowed shear flow. The polymer modified emulsions c 60 BP 1–S shows much more promising results than bitumen emulsion c 60 BF 1–S.

### 3.2 Results from samples taken from roads and city streets

The research was composed from taking asphalt cores from selected roads and laboratory testing the bonding strength of asphalt layers. The samples were taken in the wheel-path and between the wheel-path of selected roads and streets. A range of the samples were with geosynthetics interlayer, stress absorbing membrane interlayer (SAMI) or bitumen emulsion interlayer. The testing combinations and results from laboratory testing are presented in Table 2. The asphalt cores sampled according to the LST EN 12697–27:2002 standard and the asphalt layers bonding strength determined according to the Asphalt Testing Technical Directive-Part 80 (German-Technische Prüfvorschriften für asphalt, TP Asphalt–StB Teil 80). The asphalt layers bonding strength distribution dependent on testing combination presented in Fig. 3. Analyzing the asphalt layer shear force distribution was determined that 88% of the testing combinations (22 out of 25), the shear force was greater than 15 kN. The remaining 3 testing combinations results distributed: the shear force in 6.1. and 8.1 combination was 21% less than required (15 kN) and in 5.2 was 20% less than the required (12 kN). The maximum shear force identified for combinations 10.1 and 10.2 were taken from the wheel-path of road Nr. 102 where the asphalt wearing layer was made from the SMA 11 s. Whereas, the minimum shear force was identified in combination 5.2 taken from the wheel-path of Eisiskiu street. From samples taken at Plytines street, were determined that the shear force is 85% greater (3.2. testing combination) without geosynthetics interlayer than with it (3.1. testing combination). Testing of samples selected from Eisiskiu street showed about 30% greater shear force samples without geosynthetics (5.1. testing combination) than with geogrid Hatelit c 40/17 (5.3. testing combination), and even a 2.7 times greater shear force (5.2. testing combination) than with geogrid Armatex RSM 50/70. Insufficient asphalt layer bonding strength also has been identified from selected samples at road Nr. 153, Nr. 130 and Nr. 143.

It was determined that the shear flow changes independently from testing combination, but the flow is influenced by the material used in the interlayers. Shear flow in 72% of testing combinations (18 out of 25) was within the range from 2.0 mm to 4.0 mm. From samples taken at Plytines street, were determined that the shear flow is 35% lower with geosynthetics interlayer than without it. Meanwhile testing of samples selected from Eisiskiu street showed about 40% greater shear force samples without geosynthetics than with geogrid Hatelit c 40/17 (5.1. testing combination), and with geogrid Armatex RSM 50/70 (5.2. testing combination). A relatively high and exceeding the ZMT M-V recommended shear flow range was identified in samples 1, 2 and 13.1. In sample 1 and 2, a special asphalt mix SAMI 0/5 was used for the interlayer and SMA 11 s for 13.1. It can be noticed that chosen testing combinations with

asphalt wearing layer SMA 11 S (10.1, 10.2 road Nr. 102 and 13.1, 13.2 road Nr. A14) the shear flow wasn't significantly higher compared to other types of asphalt wearing layer shear flow. It was obtained that the shear flow changes independently from place of sample taking, whether the sample was taken in the wheel-path or between it.

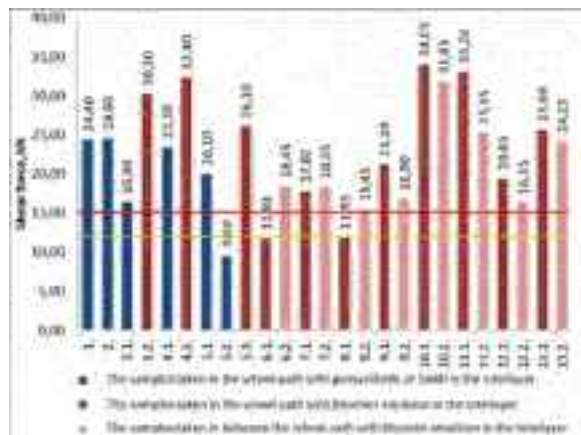

**Figure 3** The distribution of shear force between asphalt layers in samples cored in roads and city streets.  
— - the lowest allowed limit of shear force between the asphalt wearing and binder layers (15 kN).  
— - the lowest allowed limit of shear force between all other asphalt layers (12 kN)

## 4 Conclusions

- 1 The analysis of the asphalt layer bonding strength results shows that after 10 days of asphalt compaction, the bonding strength in all cases was greater than 25 kN and the shear flow was greater than 1.5 mm.
- 2 The shear force results of samples with 100% compaction of asphalt wearing layer was 13% (AC 11 VN) and 18% (AC 11 VS) higher comparing with 97% compaction degree.
- 3 All tested samples, which asphalt wearing layer was from the AC 11 VN, was determined greater value of av. 26% (tested after 2 days) and av. 54% (tested after 10 days) comparing with values of asphalt wearing layer made from the AC 11 VS. In this case the bitumen emulsion wasn't use in the interlayer.
- 4 Experimental research has indicated that the bonding strength between asphalt layers decreases from 20% to 50% when the geogrid is laid between asphalt layers. The use of geosynthetics also influence on shear flow reduction.
- 5 It was also determined that the amount of bonding emulsion C 60 BF 1-S influence on asphalt layers shear force and its values were distributed from 22,8 kN (tested after 2 days) and from 32,7 kN to 44,8 kN (tested after 10 days). The bonding strength was about 30% greater with bitumen emulsion in asphalt interlayer than without (tested after 2 days) and no significant difference tested after 10 days.

**Table 2** The testing combinations and results from laboratory testing of samples taken from roads and city streets

Testing combination	Paving year	Sampling location		The mix of asphalt wearing layer	The type of material in the interlayer	Shear force [kN]	Shear flow [mm]
1.	2010	Oslo str., Vilnius	In the wheel-path	AC 16 AS	SAMI (under binder layer)	24,40	5,90
2.	2005	Savanoriu str., Vilnius	In the wheel-path	SMA 11 S	SAMI (under wearing layer)	24,60	6,10
3.1.	2006	Plytines str., Vilnius	In the wheel-path	AC11VS	Pavegrid G100/100 (under binder layer)	16,40	2,20
3.2.			In the wheel-path		Without geogrid	30,30	3,40
4.1.	2007	Kalvariju str., Vilnius	In the wheel-path	SMA11S	Pavegrid G100/100 (under wearing layer)	23,50	2,80
4.2.			In the wheel-path		Without geogrid	32,40	3,50
5.1.	2007	Eisikių str., Vilnius	In the wheel-path	SMA 11 S	Hatelit C 40/17 (under binder layer)	20,10	1,80
5.2.					Armatex RSM 50/50 (under binder layer)	9,60	1,70
5.3.					Without geogrid	26,10	1,00
6.1.	2008	Road Nr. 153	In the wheel-path	AC 11 VS	Without geogrid	11,83	1,78
6.2.			Between the wheel-path			18,45	2,00
7.1.	2010	Road Nr. 143	In the wheel-path	AC 11 VN	Without geogrid	17,82	2,55
7.2.			Between the wheel-path			18,35	2,70
8.1.	2010	Road Nr. 130	In the wheel-path	AC 11 VS	Without geogrid	11,85	2,05
8.2.			Between the wheel-path			15,45	2,78
9.1.	2010	Road Nr. 128	In the wheel-path	AC 11 VS	Without geogrid	21,20	2,08
9.2.			Between the wheel-path			16,90	2,25
10.1.	2010	Road Nr. 102	In the wheel-path	SMA 11 S	Without geogrid	34,05	4,03
10.2.			Between the wheel-path			31,85	3,95
11.1.	2010	Road Nr. 2828	In the wheel-path	AC 11 VN	Without geogrid	33,20	3,35
11.2.			Between the wheel-path			25,35	4,05
12.1.	2010	Road Nr. A4	In the wheel-path	AC 11 VS	Without geogrid	19,45	3,95
12.2.			Between the wheel-path			16,35	2,70
13.1.	2009	Road Nr. A14	In the wheel-path	SMA 11 S	Without geogrid	25,69	5,53
13.2.			Between the wheel-path			24,23	3,43

## References

- [1] Raab, C.; Partl, M. N.; Halim, A. E. 2009. Evaluation of interlayer shear bond devices for asphalt pavements, *The Baltic Journal of Road and Bridge Engineering* 4(4): 186–195 a.
- [2] Raab, C.; Partl, M. N. 2009. Interlayer Bonding of Binder, Base and Subbase Layers of Asphalt Pavements: Long-term Performance, *Journal Construction and Building Materials*, 23 (2009) 2926–2931 p.
- [3] Frohmut, W.; Ascher, D. 2007. Untersuchungen zur Wirksamkeit des Haftverbundes und dessen Auswirkungen auf die Lebensdauer von Asphaltbefestigungen, Schlussbericht zum AiF-Projekt Nr. 13589 BR/1, Technische Universität Dresden.
- [4] Schulze, K. 1979. Asphaltbeton mit erhöhtem Füller-Bitumen-Verhältnis und dichter Belagsstruktur, *Straßen- und Tiefbau Heft* 11.
- [5] Weber, R. 1991. Rißbildungen in Asphaltstraßen als Folge mangelhaften Schichtverbundes, Dissertation TU München.
- [6] Eisenmann, J.; Neumann, U. 1993. Auswirkungen von Verbundstörungen auf die Spurrinnenbildung, Forschungsbericht Nr. 1444 (FE 07.151 G 91 K), Prüfamf für Bau von Landverkehrsflächen der TU München.
- [7] King, G. and R. May. 2003. New Approaches to Tack Application, presentation made to the 83rd Annual Meeting of the Transportation Research Board, Washington, D. C.
- [8] Roffe, J. C., and Chaignon, F., “Characterisation Tests on Bond Coats: Worldwide Study, Impact, Tests, and Recommendations”, 3rd International Conference Bituminous Mixtures and Pavements, Thessaloniki, 2002.
- [9] Dübner, R.; Glet, W. Unterhaltung von Asphaltstraßen Arbeitsgemeinschaft der Bitumen-Industrie, e.V., Hamburg, 1993.
- [10] Tashman, L.; Nam, K.; Papagiannakis, T. 2006. Evaluation of the Influence of Tack Coat Construction Factors on the Bond Strength Between Pavement Layers, Report# WCAT 06-002, Washington Center for Asphalt Technology.
- [11] Vaitkus A., Žilionienė D., Paulauskaitė S., Tuminiene F., Žiliūtė L. 2011. Research and Assessment of Asphalt Layers Bonding, *The Baltic Journal of Road and Bridge Engineering* 6(3): 210-218. ISSN 1822-427X (print), ISSN 1822-4288 (online). (Thomson ISI Web of Science).
- [12] Vaitkus, A.; Puodžiukas, V.; Motiejūnas, A.; Vitkienė, J.; Vorobjovas, V.; Paliukaitė, M. 2010. Long Term Research of Experimental Asphalt Pavement Structures, in *Transport Research Arena Europe 2010*, Brussels: Selected papers (2010, Brussels, Belgium).
- [13] Čygas, D.; Laurinavičius, A.; Vaitkus, A.; Perveneckas, Z.; Motiejūnas, A. 2008. Research of asphalt pavement structures on Lithuanian roads (I), *The Baltic Journal of Road and Bridge Engineering* 3(2): 77-83. ISSN 1822-427X (print), ISSN 1822-4288 (online). (Thomson ISI Web of Science).
- [14] Leutner, R. 1979. Untersuchungen des Schichtenverbunds beim bituminösen Oberbau Investigation of the Adhesion of Bituminous Pavements], *Bitumen* 3: 84–91.
- [15] Forschungsgesellschaft für Straßen- und Verkehrswesen, Zusätzliche Technische Vertragsbedingungen und Richtlinien für den Bau von Verkehrsflächenbefestigungen aus Asphalt zTV Asphalt–StB 07. 2007.



## ANALYSIS OF THE FLEXIBLE PAVEMENTS TRANSITIONS USING FINITE ELEMENT METHOD

Cassio Eduardo Lima de Paiva, Leandro Cardoso Trentin  
*Universidade Estadual de Campinas (UNICAMP), Brazil*

### Abstract

The Finite Element Method (FEM) is used in many engineering fields by use of advanced computer programmes. In the last years researchers are also evaluating pavement structures with the mentioned method.

The transition of different pavement structures caused the behaviour of the materials to result in differential settlement response when loaded. In this paper, a three-dimensional finite element model was developed in Ansys Programme and statics analyses were performed to evaluate the interface responses among dual wheel bridge and flexible pavement. Soil behaviour was also simulated in this study and results for different structures, in 3D FEM, were compared with a linear elastic model in ELSYM5 programme in order to validate the new model. Different pavement structures with varying base mechanical properties were developed to review the pavement response to static load in flexible pavements transitions. This difference in base material, in most cases, causes the problem of a differential settlement.

This paper tries to develop a research of flexible pavement response to one static load, in this case a dual wheel, on a bridge approach without a slab transition. Also, a comparison of compaction variations was conducted and a survey on deflections was performed.

*Keywords: Flexible pavement, Finite Element Method (FEM), Ansys program*

### 1 Introduction

Bridge approaches usually are zones of differential settlement between the structure of the bridge and the abutment, due to great displacement of the pavement structure in comparison to the bridge foundation, causing the effect of 'the bump at the end of the bridge'.

Some problems with the execution of the landfill in the abutment on the bridge approach exist. The pavement structure implemented over the landfill, in most cases, has an inadequate layers compaction. During the compaction, despite of all the effort to avoid damage in the structure near the bridge, there is a differential settlement on the bridge approach.

Safety and comfort, which a highway should provide to the user, are related to a range of factors involving users and road characteristics. Among these, the pavement's functional condition and operation speed are significant. The functional condition of the pavement, especially in the bridge approach where the driver meets an unexpected situation, in most cases does not provide safety and comfort.

The bridge approach problem unfortunately presents a reduction in safety for road users, especially at higher speeds. There the effect of the bump at the end of the bridge should be imperceptible to the driver, not causing a risk of control loss or damage to the vehicle. Other problems are the maintenance costs and premature degradation of pavement.

The interventions that are used as solutions of these problems cause partial interruption of traffic, which results in user discomfort. The interventions are usually performed in the

pavement layers where filling of the settlement might level the grade at the bridge approach. This is not a simple intervention.

The mentioned bridge approach problem has other factors involved, the erosion of the embankment or soil settlement of the foundation. To minimize these effects other solutions are used for construction, such as the use of slab transition.

The presence of a slab transition at the bridge approach has the effect of enabling the differential settlement that occurs by accommodation of the embankment [1]. The slab is designed to keep the road in level, distributing the settlement of the landfill along its length as shown in Fig. 1.

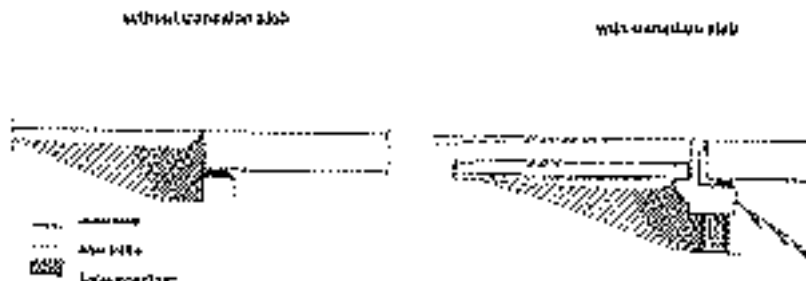

Figure 1 Differential settlement at the bridge approach [2]

## 2 Literature review

Review of the topic literature showed that the differential settlement between the bridge and the pavement structure is almost inevitable, once has a small settlement of the abutment design. Also, the pavement is designed to distribute stresses over the subgrade which is usually composed of granular material which has a deformation greater than that we see on the bridge.

The studies of Long et al [3] demonstrate that the differential settlement or discomfort for the user by the bump at the end of the bridge occur at different locations in the bridge vicinity, and depends primarily on the type of geometry of the encounter and the cause of settlement. The studies conducted in Illinois, USA, demonstrated settlement of bridges with or without transition slab at the abridge approach.

The discomfort caused by the bumping of vehicles in the end construction of the bridge, is noted by the road user when settlements have slopes greater than or equal to 50 mm. However, the studies of Long et al [3] present a better parameter that expresses this discomfort which is measured by the change of slope on the approach slab that is measured by the differential settlement divided by the total length.

Therefore, in a lack of criteria for acceptance of values of the settlement, Long et al [3] suggest values near of 1/125 for change of slope. Measures for improvement should be evaluated to minimize the effect of the bump and discomfort to the user. According this definition of measure of bridge approach, Briaud et al [4] suggests changes of slope acceptance value near of 1/200 for bridges, which guarantee safety and comfort.

Technical notes SETRA [2] discuss consideration of weather to use or not slab transition. Decision is related to the initial costs and future maintenance of the settlements.

According to Brazilian manual for bridge design [5], all bridges must have a transition slab with a thickness no less than 250 mm and a length of four meters, which must be connected to the structure or abutment through concrete joints and layed over a compacted soil in its entire length.

In the handbook for bridge inspection [6], there has been the concern with difference in stiffness between the embankment and bridge structure, even with the use of slab transition. Slab transition will eventually fail and cause an impact of vehicles at the end of the bridge. Some factors involved in the occurrence of the effect of bump on the approach are summarized in Fig. 2. [4]

The settlement of the natural subgrade is a common phenomenon in the bridges structure. It usually occurs after the beginning of loading to the landfill and requests from traffic, but in some soil types may occur along time. Therefore, an analysis of differential settlement of the embankment and bridges foundation along the time is needed, which will give subsidies for the identification of the solution to be used in this problem.

The material of the landfill must be chosen properly. Available materials near the construction site may not have a satisfactory performance. The proper compaction of material is another important factor for the bump effect reduction. Also, one may use lighter materials in the landfill in order to prevent settlement in the subgrade. The bridge foundations are usually profound and have little natural subgrade settlement. This fact is of great importance for the implementation of the bridge embankment.

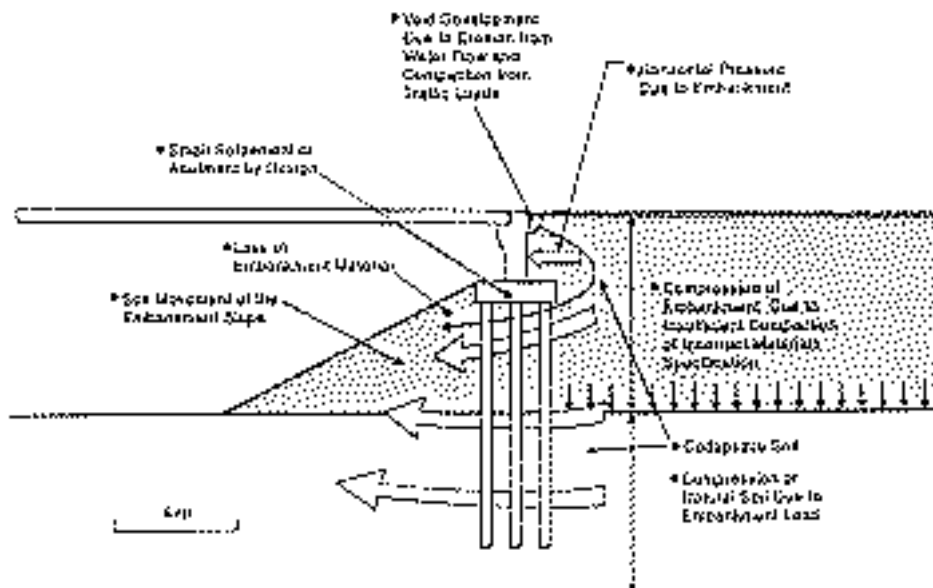

Figure 2 Problems leading to the existence of a bump [4]

In studies by Seo [7] involving the slab transition, it was observed that the frequency of loading on the slab transition is proportional to the growth of the bump and that short transition slabs result in higher displacement of the slab.

As Puppala concluded [8], the factors causing the effect of the bump are consolidation of foundation soil in the landfill, poor compaction and consolidation of fill material associated with an inefficient drainage and soil erosion.

The implementation of an appropriate drainage system in the vicinity of the bridge enables the water from penetrating into the soil of the embankment causing voids with loss of material and the consequent settlement.



### 3 Validation of the finite element model

A static analysis was performed to evaluate the model developed by Ansys Program, comparing its results with the results of ELSYM5 program, and to evaluate either using a linear elastic model is appropriate in this situation.

The program ELSYM5 [9] is based on a model of perfectly elastic layers in three dimensions. The structure can be loaded by one or more loads distributed on circular surfaces with constant pressure. The response of the structure is illustrated by results of stress, strain and displacement at defined points.

A flexible pavement can be represented by layers of materials composing the structure. In this method, elastic material is defined by homogeneous and elastic deformation that is assigned to each layer by its modulus of elasticity ( $E$ ) and Poisson's ratio ( $\mu$ ). [10]

Analysis was performed on asphalt layers 5 cm and 10 cm thick. Validation of the base was performed for thickness of 15, 20, 25 and 30 cm. The material characteristics of the asphalt concrete, base and subgrade are shown in table 1. High uniform pressure of 0.56 MPa was applied in the circular area of 10.79 cm, spaced 34 cm from each other, at the condition of dual wheel.

**Table 1** Material characteristics of pavement structure

	Concrete Asphalt	Base	Subgrade
Elastic Modulus E [MPa]	2,400	150	70
Poisson's Ratio $\nu$	0.45	0.40	0.35
Thickness [mm]	50 / 100	150 / 200 / 250 / 300	-

The numerical models were performed using the Ansys Program on a three dimensional finite element method with 20-node elements. In this analysis we used a axisymmetric finite element with 1,500 mm to horizontal and vertical directions. The comparison of the numerical results of vertical displacement for linear elastic model obtained for different layers thicknesses are shown in Fig. 3.

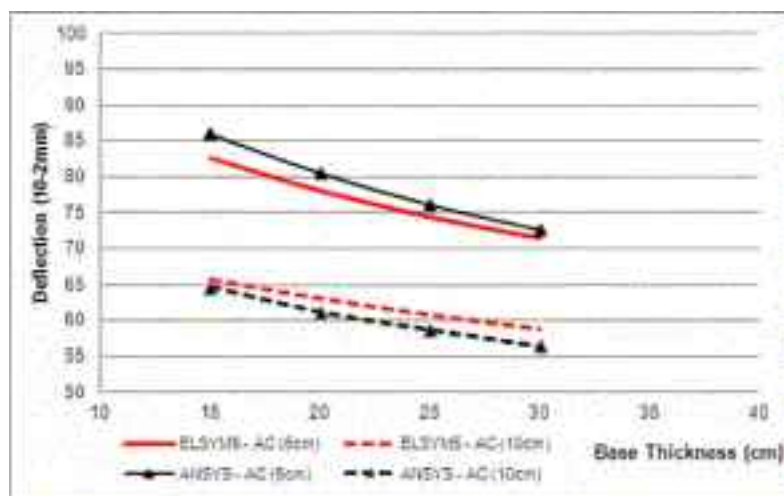

**Figure 3** Comparison of displacement in the pavement structure

## 4 Finite element analyses

For a better understanding of the settlement in embankments near the bridge approach, a numerical model for each case study was constructed in a way that fifty millimeters from the bridge abutment were three examples of compactions with variation in elastic modulus (to demonstrate a poor, normal and good compaction). The properties of the material are presented in table 2. The numerical models were performed using the finite element method, as shown in Fig. 4.

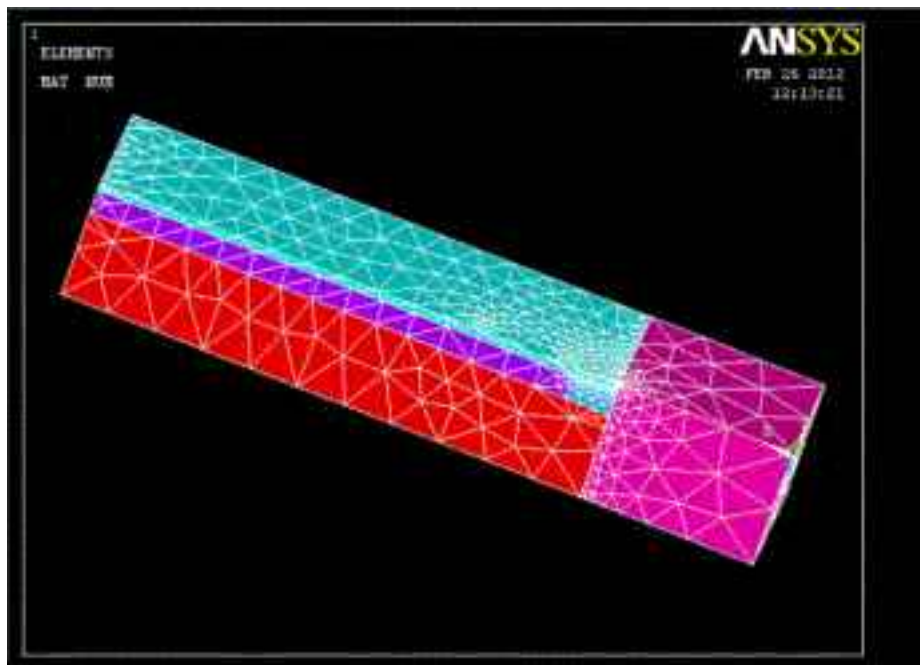
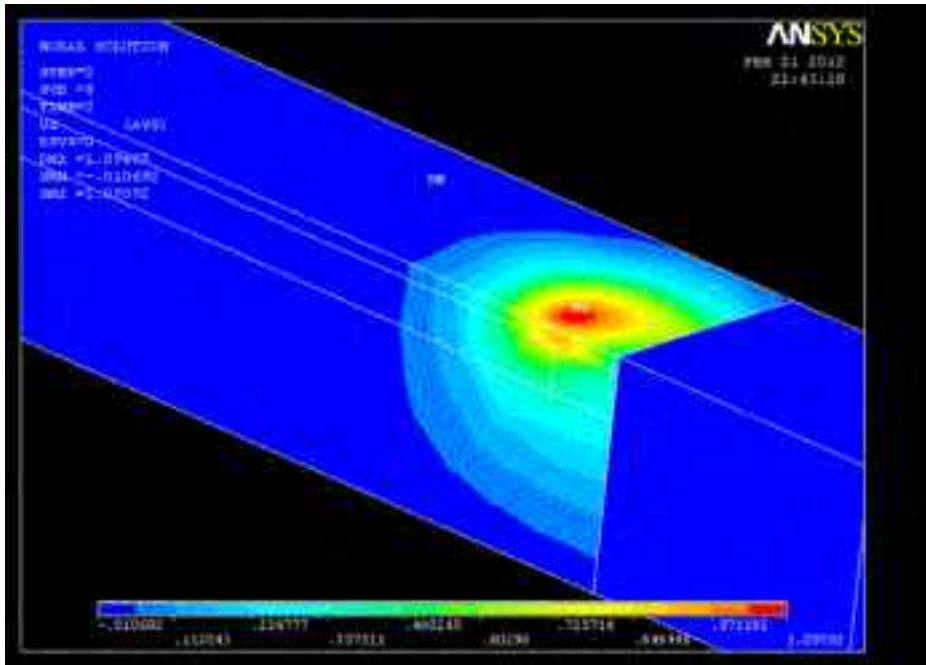

Figure 4 Numerical model of bridge approach in Ansys program

Table 2 Material characteristics of the numerical model

	Concrete Asphalt	Base	Base	Subgrade	Bridge
Elastic Modulus E [MPa]	2,400	300	150 / 300 / 450	100	30,000
Poisson's Ratio $\nu$	0.45	0.40	0.45	0.35	0.25
Thickness [mm]	100	300	300	-	-

Analyses were performed using a static load of a dual wheel with 8.2 kgf along the approximation and the bridge, as presented in the following Fig. 5.



**Figure 5** Numerical results of displacement in bridge approach

Table 3 presents the numerical results (calculated vertical displacements along the bridge approach) for each of the cases studied. It can be noted that a differential deformation between the bridge and embankment occurred, especially in the bridge approach even in case of good compaction (case III).

**Table 3** Numerical results from the bridge approach model

Example	Over de Bridge	Distance until the bridge beginning [mm]		
		0	500	1500
I – Poor compaction	$8 \times 10^{-3}$ mm	$403 \times 10^{-2}$ mm	$109 \times 10^{-2}$ mm	$81 \times 10^{-2}$ mm
II – Normal compaction	$8 \times 10^{-3}$ mm	$298 \times 10^{-2}$ mm	$101 \times 10^{-2}$ mm	$81 \times 10^{-2}$ mm
III – Good compaction	$8 \times 10^{-3}$ mm	$258 \times 10^{-2}$ mm	$96 \times 10^{-2}$ mm	$81 \times 10^{-2}$ mm

## 5 Conclusions and recommendations

In the vicinity of the bridge, in most cases, occurs the formation of a differential settlement between the structure and the pavement, caused by the greater deformation of the embankment that may be due to several factors, such as erosion, loss of material and disruption of the subgrade soil natural characteristics, among others.

Therefore, the main cause of differential settlement, causing the effect of the bump at the end of the bridge, is the deformation of the landfill material. This deformation is a consequence of lack of technological control, adequate procedures or choice of soil, and it causes formation of settlement in the bridge approach.

The validation of the three dimensional finite element method using Ansys is performed with the program Elsyn5 – the models present similar results to the same condition. In the analysis of the bridge approach, it was observed that there is always a differential settlement between the landfill and the bridge, even in case of enhancing compaction near the abutment.

In the last 20 years, recommendations were proposed in different countries to reduce the occurrence of landfill settlements near the bridge, but in Brazil this fault still occurs frequently in new constructions.

## References

- [1] Hoppe, E.J Guidelines for the Use, Design, and Construction of Bridge Approach Slabs, Transportation Research Council, VTRC00-R4, Virginia, USA, 1999.
- [2] SETRA, Dalles de Transition des Ponts Routes – Technique et Réalisation, Ministère de L'Urbanisme du Logement et des Transports, France, 1984.
- [3] Long, J.H., Olson, S.M., Stark, T.D. Differential Movement at Embankment/Bridge Structure Interface in Illinois, Transportation Research Record No 1633, Transportation Research Board of the National Academies, D.C., USA, 1998.
- [4] Briaud, J.L., James, R.W., Hoffman, S.B. Settlement of Bridge Approaches (the bump at the end of the bridge), NCHRP synthesis 234, Transportation Research Board, Washington, USA, 1997.
- [5] DNER. Manual de Projeto de Obras-de-Arte Especiais, Departamento Nacional de Estradas de Rodagem, Diretoria de Desenvolvimento Tecnológico, Divisão de Capacitação Tecnológica, Rio de Janeiro, Brazil, 1996.
- [6] DNIT. Manual de Inspeção de Pontes Rodoviárias, Departamento Nacional de Infra-Estrutura de Transportes, Diretoria Planejamento e Pesquisa, Instituto de Pesquisas Rodoviárias, Rio de Janeiro, Brazil, 2004.
- [7] Seo, J., Ha, H. S., Briaud, J.L. Investigation of Settlement at Bridge Approach Slab Expansion Joint: Numerical Simulation and Model Tests, Rep. No. FHWA/TX-03/4147-2, Texas Transportation Institute, Texas, USA, 2002.
- [8] Puppala, A.J., Saride, S., Archeewa, E., Hoyos, L.R. Recommendations for Design, Construction and Maintenance of Bridge Approach Slabs: Synthesis Report, The University of Texas at Arlington, Texas, USA, 2008.
- [9] FHWA 'ELSYM 5 – User's manual for IBM-PC and compatible microcomputer', Report No. FHWA-TS-87-206, Federal Highway Administration, Washington, USA, 1986, 32p.
- [10] AASHTO 'Mechanistic-empirical pavement design guide of new & rehabilitated pavement structures', NCHRP 1-37A, Transportation research board, Washington, USA, 2004.



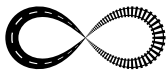

## COMPARISON OF THE LABORATORY AND FIELD TESTS USED FOR PAVEMENT DESIGN

Lenka Sevelova<sup>1</sup>, Jaroslav Hauser<sup>2</sup>, Alice Kozumplikova<sup>3</sup>

*1 Department of Landscape Management, Mendel University in Brno, Czech Republic*

*2 Geostar, spol. s r.o., Czech Republic*

*3 Department of Environmentalistics and Natural Resources,  
Mendel University in Brno, Czech Republic*

### Abstract

Many present empirical design methods are based on CBR tests of underlying soils – pavement subgrade. On site testing consists of different methods, and obviously there are problems with comparing these two approaches. The authors deal with the comparison of testing, carried out both on site and in a laboratory, performed to determine deformation characteristics of the materials. These are consequently verified for use in numerical FEM models. The results of this comparison are presented.

*Keywords: CBR tests – California Bearing Ratio, subgrade, pavement, FEM*

### 1 Low volume road design methodology/design principle

During the design of forest roads/low volume roads we need to respect many specifics of this construction type that arise from the differences in transport of wood and the terrain demands of accessed forest areas. The transport of wood is done in the terrain with low bearing capacity value, unfavourable water regimen and higher longitudinal inclinations. In comparison with public roads, smaller speeds of transport units cause higher static effects and also increase load effects.

Forest roads belong to purpose-built or local communications with regard to traffic loads and in accordance with the existing technical regulations; they are designed as non-rigid roads covered with asphalt layers or unbounded materials, exceptionally they are designed as rigid. According to the Czech technical directive TP 170, the existing analytical design method for non-rigid pavements is classified as theoretical-empirical. It is based on the n-layer elastic half-space principle. The design characteristics are subsoil parameters, climatic conditions and traffic loads. A pavement subgrade depends on the type of soil and climatic factors, and is characterized by the CBR bearing ratio under optimal CBR<sub>opt</sub> and saturated CBR<sub>sat</sub> conditions. Load bearing capacity of the active zone is defined by three subsoil types P1 to P111 with minimal values of the deformation modulus  $E_{def,2}$  that must be achieved during soil acceptance during construction (see Tab. 1).

**Table 1** The subsoil type table for TP 170 catalogue sheets

Subsoil type	P I	P II	P III
Subsoil frost susceptibility	non-susceptible	slightly susc. to susceptible	susceptible
Min. deformation modulus $E_{def,2}$	90 MPa	60(45) MPa	45(30) MPa
Design elasticity modulus $E_{np}$	120 MPa	80 MPa	50 MPa
CBR <sub>sat</sub> (acc. to standard CSN 73 6133)	50 %	30 %	15 %

## 2 Subgrade characteristics and pavement designs according to the Czech Transport Ministry TP 170 Directive Method

Generally, cyclical moisture content change processes occur during the year in pavement subsoils in dependence on climatic and hydrogeological territorial conditions. A water regimen defines the change progression and the degree of moisture content distribution in the subsoil, and also the ground water character in the soil and its knowledge is necessary in the TP methodology in order to determine the CBR load bearing capacity.

The CBR load bearing capacity ratio is, according to TP 170, done on samples under optimal - CBR<sub>opt</sub> and saturated CBR<sub>sat</sub> moisture content. To determine CBR values under design conditions we need to consider a specific water regimen. The CBR design conditions are necessary to determine the design subsoil elastic modulus and the subsoil types P I to P III.

Favourable (diffuse)

$$h_{pv} > h_{pr} + 2h_s \quad CBR_{opt} \quad (1a)$$

Unfavourable (pendular)

$$h_{pr} + h_s < h_{pv} < h_{pr} + 2h_s$$

$$CBR_{pen} = CBR_{opt} - 0,6(CBR_{opt} - CBR_{sat}) \quad (1b)$$

Very unfavourable (capillary)

$$h_{pv} < h_{pr} + h_s \quad CBR_{sat} \quad (1c)$$

where

- $h_s$  is the height of capillary rise (m) that is, according to TP 170, determined from the grain size curve with the grains  $< 0.02$  mm
- $h_{pr}$  is the depth of freeze-through (m) that is determined from the frost index  $Im$ , according to CSN 73 6196 or TP 170 from the relationship  $h_{pr} = 0.05 Im_{0.5}$
- $h_{pv}$  is the depth of ground water from the surface (m).

In exceptional cases, and only for cohesive fine-grained soils, the water regimen can be roughly determined from the consistency number  $I_c$ . The subsoil types are differentiated according to the frost susceptibility of soils and their load bearing capacity that is currently declared by two different parameters. According to the TP design methodology the plain active zone bearing capacity is given by the minimum deformation modulus  $E_{def,2}$  obtained from the static loading plate test. This parameter is used to check compression during acceptance of ground plain according to Tab. 2. At the same time the subgrade load bearing capacity is expressed by the CBR ratio value obtained from a laboratory test under design conditions.

**Table 2** The required minimum deformation modulus values  $E_{def,2}$  at the pavement plain

Required modulus of deformation $E_{def,2}$ (MPa)	Subsoil characteristic (acc. to USCS)
30	Silty and clayey soils ML, MH, CL, CH
45	Mechanically improved fine-grained silty and clayey soils ML, MH, CL, CH Sands and gravels SP, SW, SM SC, GM and GC, meeting CBR $\geq$ 15%,
60	SP, GM a GC at design CBR $\geq$ 15 % Active zone made of soil improved by bond mixture at CBRsat $\geq$ 10 %
90	Rock loose material, modified rock underbed, GW and GP soils, Soils improved by adding bonding agent at CBRsat $\geq$ 50 %

Pavement design follows the knowledge of the above mentioned characteristics that include the design level of breakage, design situation given by the design period, climatic conditions, subsoil characteristics, and the design elastic modulus. The design elastic modulus  $E_{pd}$  is determined based on the knowledge of CBR value from the water regimen conditions (1a-c), and from the relationship (2).

$$E_{pd} = 17.6 \text{ CBR}^{0.64} \text{ (MPa)} \quad (2)$$

The equation (2) was taken over from England, where this relationship was verified on certain types of clayey and silty soils. That is why in CR field measurements we use CBR 2 % to 12 %. For the values higher than CBR 30 % we introduce a constant  $E_{pd}$  modulus value of 150 MPa. The design elasticity modulus  $E_{pd}$  is defined for the behaviour of subgrade under the pavement at moisture content that corresponds to the design water regimen and for short period loads occurring during vehicle passage.

The CBR value thus became a basic parameter for the construction dimensioning of pavements. Especially designs of non-rigid pavement were and still are derived from the subsoil CBR value.

The earth body and active zone are designed for specific load capacity values according to TP and CSN 73 6133, and the design is limited by regulations on possibilities of use of specific materials for the given level of breakage. The load capacity values are unequivocally defined by the deformation transformation modulus  $E_{def,2}$  that is checked at the subgrade and in other construction layers during construction. The rules concerning protection against breakage and pollution by moving of construction machinery and storage of construction materials apply to the active zone surface. This protection also applies to water drainage. Tab. 2 specifies minimum values of CBR load capacity ratio in saturated conditions and the  $E_{def,2}$  deformation modulus, at which the soil for the active zone can be used without improvement. Relationships of both parameters were the subject of several studies (for example Pospisil, 2003) already; however, unambiguous and suitable correlations between both parameters were not definitely proven. According to the active zone control study performed by the Construction Faculty of the University of Zilina values of the parameters that define load bearing capacity within the construction quality checking are significantly higher than the considered project values. This discrepancy and the term confusion of deformation modulus and elasticity modulus lead to inadequate over dimensioning of pavements. Conclusions of this study recommend unification of the criteria for evaluation of earth plain load bearing capacity and unambiguous specification of characteristics used for design and quality evaluation.



### 3 Some problems during determination of California Bearing Ratio – CBR

So called CBR (California bearing ratio) bearing ratio is currently used for determination of soil bearing capacity of subsoil and individual road construction layer materials. The CBR test was developed in California in nineteen thirties as a material characteristic of road building materials, and its use expanded into the evaluation of soils in road subsoil strata; In CR this is done according to the European standard /1/.

The CBR test for determining the load bearing capacity should simulate soil behaviour in the road construction as faithfully as possible; therefore the surface of a test sample is loaded by metal surcharge collars, whose weight should substitute the effects of the load imposed by a future road. According to /1/ a surcharge collar weighing 2 kg erroneously represents an extra road load of 700 mm, instead of correct 70 mm.

The effect of this extra load on transport communications was investigated in our laboratories. In most cases we have found significant decrease of CBR /4/ and /5/ values of up to 50% both on original soils and soils improved by hydraulic binders while using the correct number of collars. We have also investigated the rise and fall of a sample surface while exceeding the soil load bearing capacity, which is mostly the case with CBR tests – see /2/. The original assumptions of behaviour of all samples as circular bases during the CBR tests were not confirmed.

### 4 Static Plate Load Tests – SZZ

The most important parameter of the soils and subgrades of pavements is so called deformation modulus  $E_{def,2}$  that is determined by the static load test from the second load cycle. As was mentioned above, in CR this parameter is used for the subgrade and road construction layer quality evaluation within control tests on site. This test is also sometimes used to determine elasticity modulus.

The circular plate load tests belong to basic field tests for determination of deformation parameters of subsoil and unbounded construction layers. According to the way the test is arranged and used elasticity theory, the test can be used to determine the total deformation static modulus  $E_{SZZ,e}$ , elasticity static modulus  $E_{SZZ,e}$ , instantaneous deformation modulus  $E_0$  or the foundation reaction modulus  $K$ . The main use of the static plate load test (SZZ) is the determination of 'the load bearing capacity' of the loaded layer using the deformation modulus  $E_{def,2}$ .

The general procedure of the load test lies in the application of load through a circular plate to the foundation and determination of the corresponding deformations. The circular plate dimensions correspond to the construction purpose. A plate with the 300 mm diameter is used for road construction in CR. For transport construction purposes the tested surface is gradually loaded to the effective stress value of 500 kPa and the secant deformation modulus is determined from the approx. interval of 150 to 350 kPa. However, if a deformation of 5 mm is achieved, the test is brought to a halt, and the deformation modulus is recalculated for the interval of 0.3 to 0.7 multiple of the stress that corresponds to the 5 mm deformation.

### 5 Subsoil model behaviours after loading for FEM

The knowledge of deformation characteristics of used construction materials and soils that will participate in the interaction of the construction and subsoil system is crucial for the construction design. The basic deformation characteristic is the elasticity modulus that is, according to the Hook's law, defined as the original secant modulus (Fig. 1). For natural materials that are used for line constructions, where permanent deformations predominate over the elastic ones, the deformation transformation modulus that is defined as the secant modulus (Fig. 1) is used to describe mechanical behavior. The secant modulus  $E_{50}$  is defined for the reference stress at 50% stress during breakage, and is used to calculate areal foundations.

Transformation characteristics that depend on instantaneous structural properties cannot be derived from the subject matter, but they have to be derived from suitably selected experimental me-

asurements. Current geotechnical procedures offer many tests and modulus values derived from them. During deformation of foundations and unbounded materials there is both soil compression, i.e. decrease in volume, and shear movement with consequent squeezing of material along originating shear planes. Therefore it is necessary to know the geotechnical characteristics, the modulus and the Poisson's number and the strength characteristic properties given by the angle of internal friction and cohesion. Suitable definition of physical and mechanical materials used for road construction is a basic task for the subgrade quality evaluation, strength and load bearing capacity determination, and last but not least, the determination of road thickness. These properties are given by the strength and deformation characteristics that determine the bearing capacity of materials to resist outside forces and deformation.

The subsoil material and construction layer characteristics are empirically defined for the purpose of road design, or they can be obtained during laboratory tests. Their selection and methods of determination change according to the requirements of calculation model developments. For a few decades a 'classical' design of road construction composition based on CBR values originated from the laboratory tests of broken subsoil materials was used, although non-rigid roads were rarely broken due to the loss of strength of their subgrade.

CBR is a soil and unbounded road layer characteristic used for both determination of the bearing capacity of subgrade, and also it is a base of the current design methods for road construction dimensioning in order to determine the subsoil modulus. Characteristics are sought and relationships defined, with which we can obtain the design CBR elasticity modulus  $E_p$  (MPa). Among the most known is the median design subsoil modulus  $E_{pn}$  obtained from nomograms, or for example the following relationships (TP 170; 2004). At the same time the correlation between CBR and the deformation modulus  $E_{def,2}$  is monitored and sought, for example in /6/.

$$E_p = 10 \text{ CBR (MPa)} \quad \text{for CBR} < 5 \% \quad (3)$$

$$E_p = 17.6 \text{ CBR}^{0.64} \text{ (MPa)} \quad \text{for CBR} > 5 \% \quad (4)$$

## 6 Results

Different methods of deformation moduli preparation using finite element method numerical modelling are used for material models and differ in their approach to simplification of strongly inhomogeneous soil environment, and with more or less accuracy describe the behaviour of materials after loading. Figs. 1 to 5 document the realistic distribution of stress under the plunger during modelling of CBR test using FEM. FEM was also used to create a behavioural model of subgrade on site during loading by the static load test. Results for the stresses of 500 kPa and 1250 kPa are shown in Figs. 6 and 7.

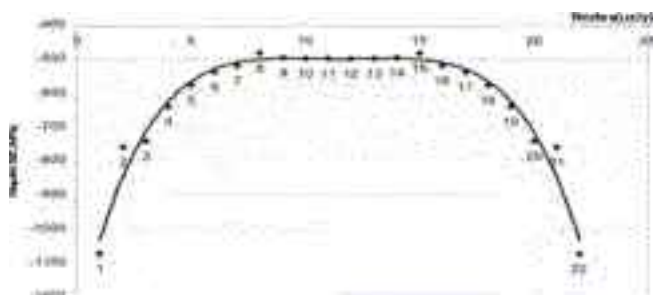

Figure 1 The stress under the penetration plunger during the simulation of CBR test using the FEM model.

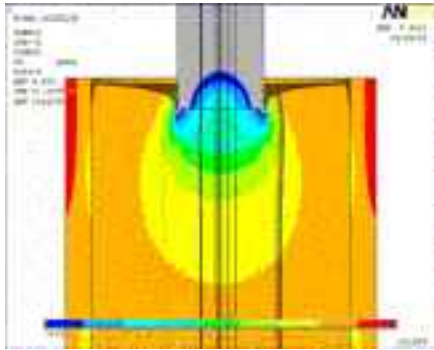

Figure 2 The vertical direction stress SZ.

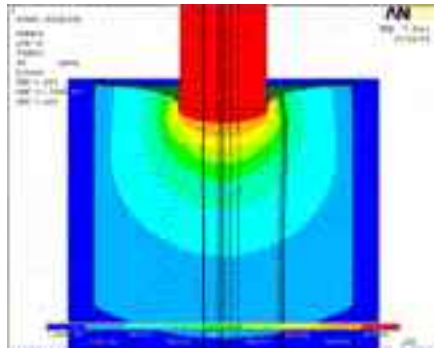

Figure 3 The vertical deformations UZ.

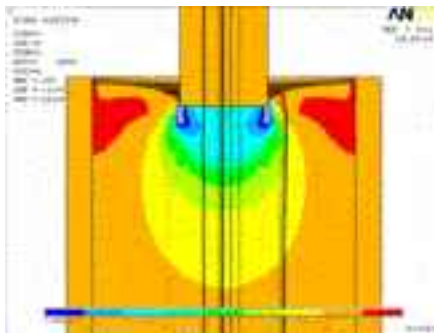

Figure 4 The relative deformations in the vertical direction during 3 mm penetration.

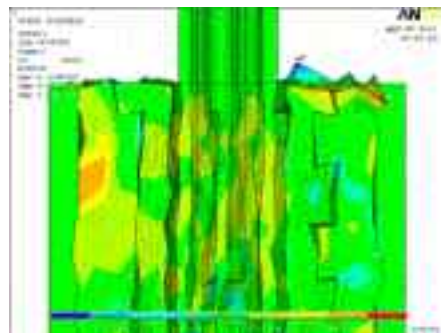

Figure 5 The relative deformations in the vertical direction during 10 mm penetration.

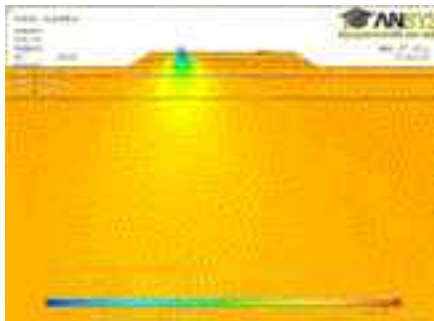

Figure 6 The vertical stress in the underbed during 500 kPa stress.

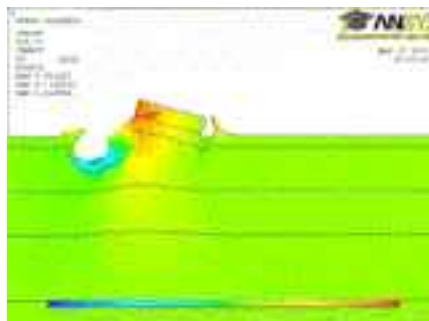

Figure 7 The breakage of the model during the 1250 kPa stress.

During the calculation of maximum stress applied during this test, and equal to 500 kPa, the model shows the resulting deformations very similar to the actually measured values – see Fig. 6. If the subgrade is loaded by the stress value equal to the stress under the penetration plunger in the CBR testing equipment (Fig. 7), the model collapses similarly as it broke after exceeding of the 1<sup>st</sup> load capacity limit.

## 7 Conclusions

Based on the comparison of two approaches, and thus obtained stress values and deformations from CBR and the load test on site, we can see that it is impossible to derive deformation and elasticity modulus values from the CBR test. According to our results we have breakage of the sample by shear during the CBR test, and also a significant decrease of CBR values occurs during the use of surcharge collars that substitute for the weight of the road, with concurrent sinking of the sample surface.

During the evaluation of transport construction subgrade we performed the determination of deformation and elasticity modulus found after the cyclical loading of the samples. Contrary to the original findings of prof. Molenaar that designed the CBR cyclical test, effective stresses at the penetration plunger tip will have to be modified during further tests, in order not to exceed real stresses caused by transport of tested material located in the road construction. Maximum stresses will be derived for various materials and used as the maximum for CBR cyclical tests.

## Acknowledgements

The work was supported by the Technology Agency of Czech Republic as the project TA01020326 'Optimization of design and realization of low capacity road pavements'.

## References

- [1] CSN EN 13286 – 47 (2005). Test method for the determination of California bearing ratio, immediate bearing index and linear swelling.
- [2] Hauser, J., Sevelova, L., Kozumplikova, A. (2010). Parametry CBR a IBI materialu do zemnich konstrukci dopravnich staveb, in 38. konference se zahranicni ucasti Zakladani staveb Brno 2010 - Sbornik prispevku. 1. Ed. Brno: Sekurkon, s.r.o., p 60-65. ISBN 978-80-86604-51-0.
- [3] Hauser, J., Kozumplikova, A., Sevelova, L. (2011). Zkoušky CBR a IBI při navrhování zemního tělesa a konstrukčních vrstev dopravních staveb. [CD-ROM]. in Geotechnicke problémy liniovych stavieb. Bratislava, p 101-108. ISBN 978-80-227-3504-9.
- [4] Hauser, J., Kozumplikova, A., Sevelova, L. Zkousky CBR a IBI podlozi a nestmelenych podkladnich vrstev vozovek, Asfaltové vozovky Ceske Budejovice (2011).
- [5] Hauser, J., Kozumplikova, A., Sevelova, L. (2012). The influence of the Soil Treatment On the CBR Test values, International Conference on Ground Improvement and Ground Control (ICGI 2012) in print
- [6] Pospisil, K. Predvidatelnost modulu pretvarnosti, Geotechnika magazine 1/2003.



## 7 ROAD MAINTENANCE



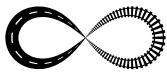

## WORLD–CLASS PERFORMANCE BASED MAINTENANCE CONTRACTS – RECENT TRENDS

**Pekka Pakkala, Antti Talvitie**

*Aalto University, School of Engineering,*

*Department of Civil and Environmental Engineering, Finland*

### Abstract

Performance Based Maintenance Contracting (PBMC) for roads has been used for many years in response to the pressure for the road agencies/administrations to improve efficiency and provide better maintenance services. This pressure from the decision–makers has resulted in further advancements, which in turn require rethinking PBMC. Several countries are outsourcing the maintenance services and it is vital to have a healthy market of service providers. The paper will discuss the findings from two recent research projects, which studied several progressive countries and progress internationally in the provision of maintenance services. The objective of the paper is to present the recent international trends in PBMC. It benchmarks and monitors international practices and presents results, challenges, practices and benefits from using PBMC world–wide. The paper concludes that for full benefits and satisfactory outcomes of PBMC it is important to maintain a functional service provider market.

*Keywords: Performance Based Maintenance Contracts (PBMC), outsourcing, maintenance, trends, maintenance contracting*

### 1 Introduction

Several countries around the world are beginning to outsource the routine maintenance services for the road network in one inclusive contract. The reasons include the reduction in public administrations, cost savings, and the advantages of private sector innovations and practices. Road administrations or agencies (herein referred to as road administration), desire to increase productivity, improve efficiency and utilize better or innovative practices. However, many countries still continue to provide services by their own workforce or direct labor force. Sometimes they do outsource some services, but only through selected activities.

Most road administrations that outsource routine maintenance in one inclusive contract are using a performance–based approach, which is often termed as Performance Based Maintenance Contract (PBMC). A PBMC is defined as an entity (usually a private service contractor – herein referred as the Contractor) that is responsible for maintaining and managing the road assets to a predefined set of conditions or services levels. The intention in a PBMC was to allow the private sector involvement and to develop and use practices that encourage innovations and new product developments. As road administrations were being downsized, PBMC was considered as a possible solution.

The principal differences between the traditional and performance based contracts are that in the latter more risks are shifted to the service provider, there is a potential for cost savings, less administration, more reliance on asset management, and the possibility for innovations. It is very important that the road administrations define appropriate service levels for performance requirements in the contract because the performance measures are the heartbeat of a



PBMC. The contractor is responsible for managing and maintaining the assets to the specified service levels and establishes a strategy and a plan to meet these service levels. The contractor is also responsible for management, operations, administration of the services. This means the contractor should have well-developed administration, accounting, staffing and planning systems, and systems for quality control, modern project management capability, and preferably also for maintenance management (or utilize those supplied by the road administration). This paper highlights the results obtained from two recent international projects that were completed for the Swedish Road Administration (now known as Swedish Transport Administration) and for Sweden Productivity Committee. The first was an international study of winter road services, pavements, rest areas in cold climate regions, which included R&D and environmental considerations. The study was titled 'The Road to Excellence' [1]. The second international study was to determine which type of maintenance contract can best influence the productivity of contractors and was titled 'Improving Productivity Using Procurement Methods – an international comparison' [2]. The first study involved both authors of this paper and the second study was completed by the corresponding author. The results of these studies, the author's experiences in the two studies and elsewhere, and other pertinent details will be reflected throughout the paper.

It is wise to study international trends and developments so that modern and innovative practices can be incorporated or adapted into the existing maintenance programs.

## 2 Methodology and objective

There have been many studies and reports regarding Performance Based Maintenance Contracts (PBMC). This paper will include resources through published reports, technical papers, contacts with road administrations and from the results of the two recent studies mentioned earlier. The intent of this paper is to highlight the most recent practices, determine recent trends, results, challenges, and practices used in some of the most progressive countries. In addition, a listing of the lessons learned will be presented for the purpose of disseminating practices that may be helpful for those considering the implementation of PBMC for the road sector.

## 3 PBMC practices

A PBMC is significantly different of the traditional maintenance contract. It requires a different approach and more 'hands off' attitude on the part of the road administration and competence for monitoring quality through spot checking and verification. Also, the tendering practices differ mainly due to the cultural differences, but PBMC can be arranged in many ways.

### 3.1 Contract requirements

In PBMC, the contractor is responsible for managing, maintaining the assets to a satisfactory condition, and administering the various duties. This means that the contractor should have well-developed technical systems identified earlier. During the procurement process the contractor is usually required to submit the following requirements in the bid:

- Work plan
- Quality Control plan
- Annual work plan
- Staffing & management plan
- Traffic management plans
- Maintenance management system
- Management of customer complaints
- Emergency contacts and procedures, and
- Cost proposal

This requires the contractor to be savvy in order to win proposals and often the smaller or traditional contractors do not have the capability or experience to manage a PBMC.

### **3.2 Routine and periodic maintenance**

Contracts can be integrated, comprehensive, or combinations of various types of activities. The common terminology used is routine and periodic maintenance. Not all activities can be included in a PBMC. In the Nordic countries the periodic maintenance is usually separate because the winters are cold and long and it is more cost effective to separate contracts for the two periods. Routine and periodic maintenance are discussed below and the nice part of PBMC is that any activity may be included, provided there are efficiency gains.

#### **3.2.1 Routine maintenance**

Routine maintenance can be defined as those maintenance activities that occur every year on a routine basis or are of a cyclic nature. These activities include winter maintenance, summer maintenance, pot hole patching, vegetation control, cleaning (signs, bridges, roads), and numerous other activities.

#### **3.2.2 Periodic maintenance**

Periodic maintenance can be defined as those activities that occur infrequently and are often referred to as 'upkeep and improvements'. Throughout the history most periodic maintenance tasks have been tendered as separate contracts, but they may be included into one single comprehensive maintenance contract. These activities include road resurfacing, bridge rehabilitation or reconstruction, safety improvements, environmental mitigation and other minor improvements.

### **3.3 Contract duration**

The contract duration is probably the most important decision that road administrations will determine in their contracts. In the beginning of the outsourcing, most countries started with three year contracts to make sure that there will be a sustained market for the road maintenance. After moderate experience, contract durations were increased to 5 years with possible annual options. Today the duration of most PBMC are in the range of 5–7 years as the increased duration tends to increase economies of scale. A distinct few, Canada for example, have progressed to over 10 year contracts. The most advanced contracts include some forms of partnering and informal dispute resolution mechanisms, where challenges and conflicts can be resolved in an amicable manner. This is because most contracts are incomplete and cannot possibly include all situations in a written document. Therefore, it is important to have trust, communications, and a procedure that will allow for resolving unanticipated events or conflicts.

### **3.4 Performance-based approach**

A performance-based approach is the main ingredient of a PBMC. It is expected to provide flexibility and boost innovation from the contractors. The challenge in developing the performance measures is the need for robust data and finding the best measures, which are normally based upon existing practices. An iterative process is recommended and may require re-engineering the measures to ensure their appropriateness. PBMC is the common maintenance practice used in the countries discussed in this paper.

There was a noticeable variation in the implementation and amount of performance-based requirements. The hybrid model (combination of performance and method-based measures) was the most common approach. It is difficult to have all measures defined in terms of outcome criteria.

## 4 Discussion and results from PBMC

PBMC have typically resulted in satisfactory results and many countries have received savings [3] compared to the traditional practices. Any change in contracting is not without challenges, but the overall results have been mostly satisfactory and desired objectives have been achieved. Some countries have achieved savings while others have demonstrated that the private market can be functional for routine maintenance. Downsizing of the road administrations has not reduced the service levels, but in fact promoted the acceptance of PBMC. Overall the PBMC model has been tested and has produced satisfactory results.

### 4.1 Trends

The common characteristic and trends from the recent and previous studies on PBMC can be summarized in the following:

- Using a Hybrid model – combination of performance & method requirements
- Longer contract duration (economies of scale)
- Larger contract areas (economies of scale)
- Bundling activities (economies of scope)
- Lowest Price Conforming Tender (LPCT)
- More service and cost risks for contractors
- Contractor collection of the asset data

### 4.2 Other practices in PBMC

There are many other issues in PBMC that are important. This is especially true for those countries that have totally divested of own work forces and reliant on private sector care for road maintenance. These factors are as follows:

- Healthy and functional market
- Availability and use of an acceptable price index
- Response time related performance measures
- Penalties for non-performance
- Focus on asset management
- Partnering

### 4.3 Challenges in PBMC

PBMC presents several challenges and obstacles for those that are in the beginning phases and for those that are contemplating the use of PBMC. Probably the biggest challenge is the decision to open the market for PBMC as there may not be a contracting profession available. Others challenges include:

- Creation of a deliberate process
- Conflicts in attitudes between the new and 'traditional' road management culture
- Development of appropriate performance measures or levels of service
- Uncertainties in the costs of meeting desired performance standard
- Distribution of risks between the contractor and the client
- Loss of control of the working means and methods
- Legal restrictions (some countries require the acceptance of low-bid with no points for quality and competence)
- Start-up costs for new contractors
- Political priorities that cannot be managed easily
- How to announce and communicate the new procurement strategy to the road administration staff and the industry

- Development of good contract documents

In any event the introduction of PBMC will take time and use resources.

## 5 Lessons learned

A long list of lessons learned [4] has been gathered from collecting and digesting lessons of experience over the past ten years. The list below is not exhaustive, but provides a broad perspective of lessons learned in PBMC. The summary is recorded below:

- Competition is the main factor to increase efficiency and potential savings
- Sustaining a healthy & functional private sector market is very important
- Changing the internal culture and practices in road administrations are difficult – PBMC is a different approach
- How to open the market for services is important – it also takes time to change the contractor culture
- Performance-based approach is preferable for as many activities as possible
- Hybrid PBMC are perfectly acceptable
- Risk allocation with a sliding scale risk (contractor bares the risk to a certain level, while the road administration bares the remaining)
- Long term contracts are better (greater than 5 years) than short term contracts
- Bundling of activities (economies of scope) is a good practice (such as including resurfacing at a fixed price)
- Larger area contracts are better (economies of scale)
- More flexibility and less restrictions is advantageous, this may include small capital improvements at a fixed cost
- Many countries have now progressed to and prefer Lowest Price Conforming Tender (LPCT)
- 'Wisdom' in measuring performance of the service providers
- Use of incentives to drive 'correct' behavior – incentives are better than disincentives (if possible)
- Mobilization of new contractors may cause early challenges (need time)
- Importance of transparent and fair tendering practices
- Good project management is needed from both the client and contractor
- Good communications between the contractor and the client is of paramount importance
- Cooperation with the private market via forums, meetings & other cooperative efforts
- Formal or informal partnering is important
- Many performance measures are with pass/fail criteria with disincentives
- Most performance measures are defined by time & response
- Contractor should collect the condition assessment data on a regular basis (eyes and ears of the client)
- Develop an interactive and interoperable Maintenance Management Systems (MMS) and ICT system as they focus on resources and performance tracking, which relates to pro-active asset management)
- Use of modern, interchangeable and intelligent equipment
- Cost information at the micro-level is being lost in PBMC
- New innovations are desired, but clients at times have difficulty accepting them
- Standardization is broadly applied (in contracts and practices)
- PBMC requires good leadership in client organization
- Several models of PBMC are in use for different market circumstances (rural versus urban)
- Consider payment schemes with incentives to match pro-active asset management practices
- Develop and use contractor past performance rating system or approved contractor classification
- Corridor based contracts may be appropriate in some markets or circumstances
- Restricting subcontracting by the main contractor (e.g. ~70% maximum)
- Learn from other countries practices rather than starting from the beginning

## 6 Conclusions

PBMC involves a cultural change from the normal way of doing road maintenance. It focuses on what to achieve (the outcomes) instead of methods how to achieve it. Each country that has adopted PBMC has also tailored the PBMC concept to their local context. Perhaps, the success of PBMC is in that each culture can apply the principle of PBMC and deliver the concept in multifaceted ways and means. Countries also evolve the PBMCs as they gain experience; a few are in their third, fourth or even fifth generation of PBMC contract development.

The trend seems to favor:

- long-term contract duration,
- a hybrid type PBMC contract model with both routine and possibly
- periodic maintenance activities,
- performance measures for area-wide networks,
- bundling of activities, using a Lowest Price Conforming Tender, and
- fair allocation of risks.

What works well in one country may find cultural difficulties in another country and does not necessarily achieve the same benefits. It is wise to implement those features that produce the gains in their domestic application of PBMC.

Having a well-organized and efficient maintenance regime certainly improves the success and the main task of the road administrations is to establish a framework for success by using maintenance contracts that provide opportunities for efficiency and productivity. This requires a learning process and re-engineering of practices to achieve desired results. The biggest challenge is to create a healthy and competitive market for the maintenance services so that innovation, efficiency and productivity can be realized.

## References

- [1] Lodenuis E., Pakkala, P., Talvitie A. 2010, The Road to Excellence – an international benchmarking project between national road administrations, Swedish Transport Administration, Sweden
- [2] Pakkala, P. (2011), Improving Productivity Using Procurement Methods – an international comparison, Sweden Productivity Committee, Stockholm, Sweden
- [3] Pakkala, P. (2005), Performance Based Contracts - International Experiences, Transportation Research Board (TRB) Performance Based Contracts Maintenance Contracting - DOT Executive Workshop, April 27, 2005, Washington D.C., USA.
- [4] Pakkala, P., de Jong, M., and Aijö, J. (2007), International Overview of Innovative Contracting Practices for Roads, Finnish Road Administration and Next Generation Infrastructures, Helsinki, Finland (2007).

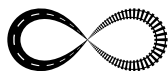

## PREDICTION MODEL FOR THE COST OF ROAD REHABILITATION AND RECONSTRUCTION WORKS

Jelena Ćirilović<sup>1</sup>, Nevena Vajdić<sup>2</sup>, Goran Mladenović<sup>2</sup>, Cesar Queiroz<sup>2</sup>

<sup>1</sup> *IMS Institute, Serbia*

<sup>2</sup> *Faculty of Civil Engineering, University of Belgrade, Serbia*

### Abstract

Maintenance of existing road network represents a challenge for public road authorities who seek a balance between available budgets and the need for maintaining level of service at a satisfactory level on existing road sections. For this reason, prediction of cost for road rehabilitation and reconstruction works represents one of key inputs for the objective analysis of projects and available budgets and optimization of road maintenance alternatives.

However, the average unit costs of road rehabilitation and reconstruction vary substantially between countries, and even between projects in the same country, due to a number of factors. In this paper an effort is made to develop a prediction model that could be applied for a wide range of conditions in different countries. A specialized dataset is used, which was generated under a World Bank study for a sample of road works contracts from 14 countries in Europe and Central Asia, signed between the years 2000 and 2010. The data sample for the analysis covers 94 projects of rehabilitation and reconstruction of flexible pavements. A multivariate regression analysis is used to evaluate the determinants of the cost per kilometer of the road rehabilitation or reconstruction.

The explanatory variables that are tested in the model are divided in three groups:

- a Variables related to oil prices
- b Variables that are country specific
- c Variables that are project specific

The variables included in the analyses were chosen in view of their potential explanatory power. The resulting regression model is expected to be useful in the strategic analysis of road networks, including the optimization of road maintenance alternatives.

*Keywords: Road rehabilitation and reconstruction works, cost prediction model, multivariate linear regression analysis*

### 1 Introduction

Public road authorities are facing a challenge of finding a balance between available funds and a need for maintaining existing road networks at a satisfactory level of service. For this reason, prediction of cost for road rehabilitation and reconstruction (RRR) works, as one of most common type of works, represents one of key inputs for the objective analysis of projects and available budgets and optimization of road maintenance alternatives.

However, the project cost for RRR works vary substantially across countries and over time, but variation also exists within the country in the same year due to a number of reasons. Thus, accurate cost estimations of RRR projects at the early stages of the road planning and maintenance programs are challenging and difficult to obtain.

During project implementation, as more detailed information become available, it is possible to derive accurate project costs. However, developing models that could estimate costs of RRR works at an early stage of project development, with minimum project information, is crucial in planning road maintenance programs. Relatively precise cost prediction models would ensure better allocation of resources and successful delivery of such programs.

This paper presents a model that can be applied for the early cost estimations of RRR works in European and Central Asia (ECA) countries where only limited project information is available. Multiple regression analysis (MRA) is used for the model development since this technique is adequate for examining potential variables, their suitability and contribution to the model.

## 2 Input dataset

The World Bank has recently performed two studies to establish a framework for cross-country comparative assessment of the procurement and implementation processes of RRR works contracts [1,2]. A specialized dataset was generated covering projects in 14 countries of Europe and Central Asia (ECA): Albania, Armenia, Azerbaijan, Bosnia and Herzegovina, Bulgaria, Croatia, Estonia, Georgia, Kazakhstan, Macedonia, Poland, Romania, Serbia, and Ukraine [2]. The data sample covered 94 completed or on-going RRR works contracts signed between 2000 and 2010 and included data for contracts above a threshold value of U.S. \$1 million. All contract amounts in local currency were converted into U.S. dollars using the exchange rate at the bid opening date [3,4]. The cost per km of RRR works did not include the cost of structures. The above mentioned study made it possible to do cross country comparison of the costs of RRR works, and inspired the idea to develop a general cost prediction model that could be used in the ECA countries for strategic planning of RRR works at the network level.

The dependent variable in the analysis was the actual cost of RRR works per kilometer, for a two-lane (7-m wide) road equivalent. The initial set of the explanatory variables included 18 variables in total. These variables can be grouped in the following three categories:

- variables related to oil price
- variables that are country specific
- variables that are project specific
- The oil price related variables included:
  - the crude oil price per barrel
  - the diesel and gasoline fuel price per liter in the country
  - whether the country is a net oil exporter or importer (a dummy variable)

The prices of gasoline and diesel fuel per liter were added to the original database. It was anticipated that these variables could be significant for the model as their price variation may affect the price of RRR works. As most of the maintenance works were performed on asphalt concrete pavements, it was expected that the price of bitumen would affect the price of RRR works. The prices of crude oil, gasoline and diesel are publicly available for all the countries and therefore were used as a proxy for the cost of bitumen [5,6,7].

Also, a dummy variable indicating whether the country was an oil exporter or importer was tested in the model for its significance (a dummy variable which took value 0 if the country was oil exporter, and value 1 if the country was oil importer). It was anticipated that the costs of RRR works should be lower in the countries that were oil exporters. This variable can be obtained from the World Bank's World Development Indicators database (WDI), which is publicly available [8]. Variables that are country specific included:

- the country's Gross National Income (GNI) per capita
- inflation
- Gross domestic product growth rate
- climate conditions
- road sector gasoline fuel consumption

- the Transparency International Corruption Perceptions Index (CPI)
- World Governance Index (WGI).

The country's Gross National Income per capita, inflation and Gross domestic product growth rate are variables used as indications of the specific economic conditions in the country in which the RRR project was implemented. Values for these indicators can be obtained from the World Bank's World Development Indicators database (WDI), which is publicly available [8]. Climate conditions were included in the analysis through a dummy variable which took the value 0 if the climate was mild and the value 1 if severe climate conditions are prevailing in the country. The variable expressing the road sector gasoline fuel consumption is added to the initial set of variables because it could be indicative, and it is easily obtained from the World Bank's WDI database [8].

Transparency International (TI) defines corruption as the abuse of entrusted power for private gain [9]. This definition encompasses corrupt practices in both public and private sectors. The CPI ranks countries according to the perception of corruption in the public sector and the score goes from 0 (highly corrupt) to 10 (very clean). The WGI measures the extent to which public power is exercised for private gain, including both petty and grand forms of corruption, as well as 'capture' of the state by elites and private interests [8].

These country specific variables were chosen to be able to identify the link between the strength of the country's economy and the possible influence of corrupted and nepotistic governments to the costs of RRR works. Variables that are project specific included:

- price of asphalt concrete (us \$ per m<sup>3</sup>)
- total number of bidders
- number of foreign bidders
- number of local bidders
- percent of local bidders
- terrain type
- expected RRR works duration (in months)
- length of the RRR works (7-m wide two lane road equivalent).

The number of bidders was used as a proxy for the level of competition in a specific contract, the rational being that costs would tend to be lower with a higher degree of competition. Percent of local bidders was calculated as a percent of local contractors compared to the total number of firms that participated in the tender.

It was anticipated that performing the RRR works of any type on difficult terrain conditions would increase the costs of the RRR works. A dummy variable was used that takes value 0 if the terrain is flat and value 1 if terrain is hilly or mountainous. The length of RRR works was expressed as the equivalent length of a 7-meter wide two lane road. The expected duration of RRR works was expressed in months, and it was expected that the cost of RRR works per kilometer in the projects with longer expected duration would be higher because those works were anticipated to be more complex and therefore more expensive.

The values for all variables were obtained, to the extent possible, at the time of bidding.



### 3 Methodology

In order to find a model which would be relatively simple for further use, multiple linear regression analysis is chosen as a method for model development and for the analysis of selected variables. The cost of RRR works per kilometer was set as the dependent variable and it was transformed using natural logarithm in order to obtain a better fit of the model. Thus, in this analysis, the regression equation was formulated as:

$$Y = e^{(\beta_0 + \sum_{i=1}^p (\beta_i \times x_i) + \epsilon)}$$

where  $y$  is the dependent variable,  $X_i$  are independent variables,  $p$  is the number of independent variables,  $\epsilon$  is the residual error,  $\beta_i$  are regression coefficients and  $\beta_0$  is a constant. Before model development, several engineering assumptions were made regarding the sign of regression coefficients. These assumptions served as the benchmark for the logical testing of the model and its results. For example, it was expected that higher prices of crude oil and its derivatives would increase the price of RRR works, as well as the severe climate and terrain conditions and the fact that the country is an oil importer. On the other hand, the costs of RRR works would decline as the level of competition, expressed through the number of bidders, increases.

Furthermore, during the preliminary analysis of the data set, the correlation between independent variables was tested, as well as the sign of regression coefficient of each independent variable. For example, after initial analysis of data, it was observed that there was a positive correlation between the crude oil and oil derivative prices and the costs of RRR works.

Four diagnostic methods were used for testing the dataset for outliers:

- Analyses of the (square) residuals
- Standardized residuals
- Cook's distance
- Leverage matrix.

The threshold value for recognizing an outlier, based on the standardized residual, was set to be  $\pm 3$  standard deviations. For the Cook's distance, the 'suspicious' points are the points with significantly different value of Cook's coefficient compared to the values in the other points (critical value is 1, as a general rule), and as for the Leverage distances, critical value is calculated as  $2.5 \cdot p/n$ ,  $p$  being the number of explanatory variables, and  $n$  being the sample size. In the selected data sample, there were no outliers identified.

The backward analysis method was used as a starting point for the analysis of variables which should be included in the model. Backward analysis is based on the removal of the variable that has the highest  $p$ -value (because its contribution to the model is the least significant). However, in this study slightly altered backward analysis was used. Variables were removed from the model if they had  $p$ -value higher than 0.1 (threshold value set in this study). Additionally, the satisfaction of engineering assumptions previously mentioned was checked in terms of logical judgment.

Also, before the final decision about the next step was made, the effect of the deletion of the selected variable on the model was reviewed by comparing the coefficient of determination  $R^2$  and adjusted coefficient of determination  $R_2$ , F-statistic, and standard error of the estimate to their values from the previous model. Therefore, developed models include variables that have regression coefficient with  $p$ -values lower than 0.1 and that are in accordance with the earlier established assumptions.

During the model development, the motivation was also to use a data sample as large as possible. For example, it was found that the terrain conditions were unknown for most contracts. Using this variable in the model could greatly reduce the size of the data sample, thus such variable was not included in the model development.

Standard regression assumptions were checked for developed models. It was confirmed that the relationship between independent variables and the dependent variable is linear. Also, the residuals follow normal distribution, have zero mean and a constant variance and are independent of each other, i.e., residuals are independently and identically distributed (iid) normal random variables [10].

## 4 Resulting regression models

In total, seven variables were selected as most significant variables when estimating the expected cost of RRR works in a country, namely: the Transparency International Corruption Perceptions Index, climate conditions of the project's country, country Gross National Income, expected participation of local contractors on the tender, expected duration of RRR works, the length of the RRR works (as the equivalent length of a 7-meter wide two lane road), and the price of asphalt concrete.

Two models were developed, each with the use of six independent variables with sample size of 43 (table 1).

**Table 1** Table 1  
Regression coefficients for model 1 and model 2.

	Independent Variable	Coefficient	Model 1	Model 2
	constant	$\beta_o$	9.912009*	11.08770*
Country specific variables	TICPI	$\beta_{TICPI}$	0.2555876*	
	Climate	$\beta_c$	0.6063567*	0.6389887*
	GNI	$\beta_{GNI}$		1.406455x10 <sup>-4</sup> *
Project specific variable	% of local bidders	$\beta_{LB}$	-7.814582x10 <sup>-3</sup> *	-6.6619297x10 <sup>-3</sup> *
	Duration	$\beta_{DUR}$	0.06392160*	0.04442844*
	Ln (road length eq)	$\beta_{RL}$	-0.3673852*	-0.2677805**
	asphalt	$\beta_{ASPH}$	0.4254832*	0.2210973***
Dependent variable	Ln (cost/km)			

\*p-value less than 0.01, \*\*p-value less than 0.05, \*\*\*p-value less than 0.1

Both models are highly statistically significant with coefficients of correlation 0.831 (model 1) and 0.835 (model 2), and adjusted coefficients of correlation of 0.803 (model 1) and 0.807 (model 2). Standard error of the estimate is 0.2782 (model 1) and 0.2753 (model 2). In order to compare the two models it is usual practice to calculate the F value that evaluates goodness of fit, taking in consideration degrees of freedom and the size of the sample. As the size of the data sample was 43 for both models, and the same number of independent variables was used in both models, F values were almost the same for both models (29.506 for model 1 and 30.258 for model 2).

The negative sign of the variable 'ln (road length eq)' regression coefficient is in accordance with the assumptions earlier established, i.e., it was expected that if the RRR work was performed on a longer section, the price per kilometer of such works would be lower. Furthermore, the price was expected to be higher if the estimated duration of the RRR works was relatively long due to more complex type of works. Also, the costs per kilometer of RRR works tend to be lower in case most of the firms on the tender are local contractors.

Figure 1 represents the comparison of actual and predicted costs. The X-axis represents natural logarithm of actual costs, i.e., contract values from the WB database, and the Y-axis represents natural logarithm of calculated costs using the equation obtained for final models.

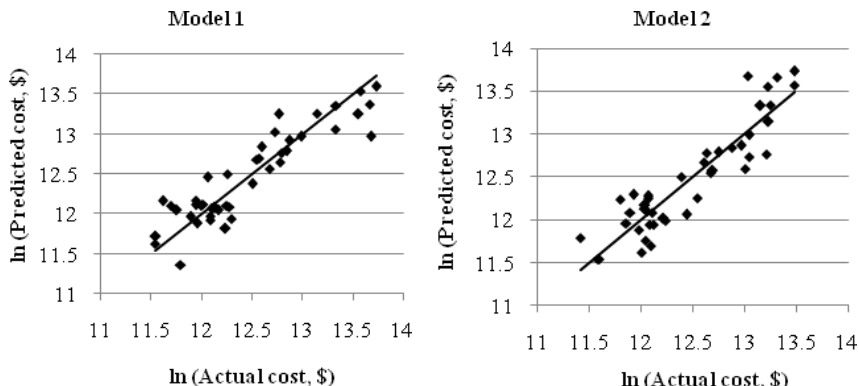

Figure 1 Comparison of actual and predicted costs for both models.

Developed models make error in estimate within the range of  $\pm 5\%$ . It should be noted that variables related to the oil price are not included in final models. However, it could be assumed that the price of asphalt concrete would reflect, to some extent, the crude oil price on the market and price of its derivatives, i.e., price of bitumen. Considering that only six values are needed as input data for the RRR cost estimates, the developed models provide a reasonable estimates for projects when only limited information is available. In other words, one can estimate the expected costs of RRR works knowing only two input parameters about the country and four input parameters about the project.

## 5 Conclusions

This paper explores the parameters based on which it is possible to estimate the unit cost of RRR works at the strategic level, i.e., when only limited information is available about a project at the planning stage.

Seven variables were found to be the most significant variables when estimating the cost of the RRR works in a particular country. Based on these variables, two models were developed and both are found to be highly statistically significant. Both models are general, covering broad spectrum of RRR works in different countries. Such models are a useful tool which allows reasonably accurate first estimates about the expected costs of the RRR works based on limited basic country and project information.

The resulting regression equations are expected to be particularly useful at the strategic level, for planning and optimization of RRR works in road networks in countries of Europe and Central Asia. Further research is recommended to focus on the analysis of contracts for RRR works in road networks in other regions, the results of which could be pooled together with the results with this research.

## References

- [1] Alexeeva, V., Padam, G., and Queiroz, C.. Monitoring Road Works Contracts and Unit Costs for Enhanced Governance in Sub-Saharan Africa, Transport paper TP-21, The World Bank Group, Washington D.C., 2008.
- [2] Alexeeva, V., Queiroz, c. and Ishihara, s. Monitoring Road Works Contracts and Unit Costs for Enhanced Governance in Europe and Central Asia, Transport paper TP-33, The World Bank Group, Washington D.C., 2011.
- [3] Bank of Canada, 10-year currency converter, available at [www.bankofcanada.ca/rates/exchange/10-year-converter/](http://www.bankofcanada.ca/rates/exchange/10-year-converter/) ,accessed 30.01.2012., 2012.
- [4] OANDA Historical Exchange Rates, available at [www.oanda.com/currency/historical-rates/](http://www.oanda.com/currency/historical-rates/) , accessed 30.01.2012., 2012.
- [5] GIZ, International Fuel Prices 2007, available at <http://www.gtz.de/de/dokumente/en-flyer-international-fuelprices-2007.pdf> , German Technical Cooperation GTZ, Eschborn, Germany, accessed 30.01.2012., 2007.
- [6] GIZ, International Fuel Prices 2009, available at <http://www.gtz.de/de/dokumente/en-flyer-international-fuelprices-2009.pdf> , German Technical Cooperation GTZ, Eschborn, Germany, accessed 30.01.2012., 2009.
- [7] GIZ, International Fuel Prices 2010/2011 data preview, available at <http://www.gtz.de/de/dokumente/giz2011-international-fuel-prices-2010-2011-data-preview.pdf> , German Technical Cooperation GTZ, Eschborn, Germany, accessed 30.01.2012., 2011.
- [8] World Bank, WDI-database (World Development Indicators), available at <http://data.worldbank.org/indicator> , accessed 30.01.2012, 2012a.
- [9] Transparency International, Corruption Perception Index, available at [http://www.transparency.org/policy\\_research/surveys\\_indices/cpi](http://www.transparency.org/policy_research/surveys_indices/cpi) , accessed 30.01.2012, 2011.
- [10] Rawlings J., Pantula S., Dickey D., Applied Regression Analysis: A Research Tool, Second Edition, Springer, pp. 228-231, 1998.





## PRINCIPLES OF ROAD MAINTENANCE BASED ON PERFORMANCE CRITERIA

Mihai Dicu, Carmen Răcănel, Adrian Burlacu, Ștefan Marian Lazăr, Claudia Petcu  
*Technical University of Civil Engineering Bucharest, Romania*

### Abstract

Evaluation of technical condition based on performance criteria during service life of a road becomes extremely necessary in terms of cost efficiency in maintenance strategies in the road administration. Using existing technical regulations by combined analysis of the technical condition evaluation in the sense that it is desired a parametric quantification of degradation occurring by traffic loads and variations in environmental conditions, practically define the actual performance level of the road at the time field investigation.

This paper aims to present an assessment scheme of intervention to measures performance criteria based maintenance, which, moreover, has been regulated in Romania too.

*Keywords: asphalt mixture, cracking, fatigue, permeability*

### 1 The general framework of the paper

One of the criteria for assessing the performance of wearing courses quality is the waterproof characteristics of asphalt layer. The road structure behaviour is based on this property, throughout the life cycle, because the presence of the water in lower layers of a road structure leads to degradation of their physical and mechanical characteristics. A bigger influence of water, inside of a road structure, happens when the water contains elements from de-icing solutions used during winter time to fight against glazed frost. In these circumstances, knowing the state of road wearing course waterproof layer is extremely important to take necessary preventive measures, so that it be restored and preserved throughout the period of the road operation. This paper aims to propose a simple qualitative method for indirect identification of waterproof state of wearing course, by the degree of road surface cracking. Thus, the next steps of analysis are listed below:

- laboratory analysis to identify road permeability layer in asphalt mixture design stage;
- identification of the permeability of asphalt layer wearing course;
- determination of the performance quality index.

Of those listed above, it can be seen that asphalt wearing course that cracked, is the one without proper maintenance and can deteriorate further because of the humidity influence. Structural damage of a road depends on the aggressiveness of external factors, one of them being the humidity excess.

Severity of degradation depends on the cracking level, which allows infiltration of large amounts of meteoric water in the road structure. It works differently onto the structural composition of each layer according to the road material used in manufacturing and technical condition of the road depending on the time of analysis. Knowing the rate of cracking and the severity, assessed by Romanian Norm 540, it is possible to predict the degradation process by the procedure presented below.

Quantifying the carriageway surface induced cracks for the qualitative assessment in terms of excess moisture, is necessary so we can determine a remedial action for prevention of the development of structural damage to roads phenomenon.

## 2 The influence of structural porosity on wearing course

### 2.1 Wearing course permeability to water infiltration

Infiltrated water in the road structure has considerable influence on its durability. A cracked pavement, so permeable, acts adversely to the phenomenon of freeze–thaw action that adversely affects the mechanical strength of the overall road structure.

Existing in structure's road layers of micro–and macro–pores, capillaries, caves, micro–and macro–cracks are structural defects that reduce quality of each layer both in terms of meteoric water permeability and the terms of mechanical strength.

Water permeability is determined by road layer porosity and the distribution, size and type of pores and cracks. Theoretically, the water permeability can be assessed by the coefficient of permeability ( $\kappa$ ) given by Darcy:

$$\kappa = \frac{Q \cdot h}{A \cdot t \cdot \Delta a} [\text{m/s}] \quad (1)$$

where:  $Q$  = water quantity [ $\text{cm}^3$ ] drained in time  $t$  [s];  $A$  = sample's transversal area [ $\text{m}^2$ ];  $h$  = thickness of the sample [m];  $\Delta a$  = collapse pressure of the liquid column in the sample (meters of water column). Practically, the impermeability rate of the road surface layer is conducted by standard methods and depends on the depth of penetration of conventional water under certain pressure, in a certain time.

### 2.2 Asphalt mixture cracking

Asphalt cracking causes are multiple and depend primarily on the structural characteristics of road materials. The causes are: cracking because of aging, reflective cracking, fatigue cracking, fatigue from a wrong mixture design and other causes.

The presence of various phases of an asphalt mixture, from the elastic behaviour in the early phase of service life and the passing to an elasto–plastic and the plastic behaviour, precede rupture, leading to various stages of cracking from micro cracks to bigger cracks.

This development of the cracking process involves various stages of wearing course permeability, which allows gradual degradation of an entire road structure, thus the appearance of defects in lower layers (base and subbase).

Knowing the evolution of this process and proposing solutions to prevent the extension of road structure degradation is important to recognize the permeability properties of asphalt wearing course. Thus, the permeability quality at of a wearing course is a priority for improving the quality of road surface.

### 3 Laboratory analysis for permeability identification at mixture design stage

The starting point is given by Darcy's permeability law, which points out the permeability coefficient. In roads sector, this principle is applied by a well known test. Thus, the permeability of a road structure is measured in situ by an apparatus called 'permeability-meter', which consists of a tube under pressure applied on a road surface, sealed at the bottom. The water flow rate, both in situ and in laboratory conditions on plate type samples of asphalt mixtures, can be measured by this apparatus (Figure 1).

The water flow rate can be determined using the Darcy law and can be assimilated to a permeability coefficient. But in this formula the road surface is not pointed out. This parameter is extremely important because it must be in correlation with the cracking degree.

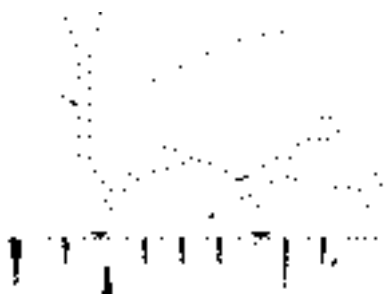

**Figure 1** The permeability meter with its components: (1) Cracked wearing course, (2) Liquid measuring container, (3) Mastic sealer bead, (4) Measuring liquid (5) Graduated tube for measuring the gradient of liquid infiltration.

In this case a notion of permeability coefficient with the notion of permeability coefficient on cracked surface must be extended;  $K_s$  and it will have the following meaning:

$$K_s = K/S [m^{-1}s^{-1}] \quad (2)$$

So the Darcy law will have the following shape:

$$K_s = \frac{Q \cdot h}{S \cdot A \cdot t \cdot \Delta a} [m^{-1}s^{-1}] \quad (3)$$

where:  $Q$  = water quantity [ $m^3$ ], drained in time  $t$  [ $s$ ];  $S$  = plain surface based on a cracked surface [ $m^2$ ];  $A$  = sample's transversal area [ $m^2$ ];  $h$  = thickness of the sample [ $m$ ];  $\Delta a$  = collapse pressure of the liquid column in the sample.

After the initial permeability coefficient  $k_{s1}$  is determined, then the cracked sample is controlled and the permeability coefficient on a cracked surface is determined.. In laboratory we can induce multiple stages of study to highlight the variation of permeability function of length and crack opening (Figure 2).





**Figure 2** Photos during work

If we take into consideration a measuring device with recipient which has a contact surface with the carriageway surface of a square shape with  $L$  side (Figure 2), then the formula proposed for  $K_s$  can be:

$$K_s = \frac{Q \cdot h}{L^2 \cdot L \cdot h \cdot t \cdot \Delta a} = \frac{Q}{L^3 \cdot t \cdot \Delta a}; \quad K_s = \frac{Q}{L^3 \cdot t \cdot \Delta a} [m^{-1}s^{-1}] \quad (4)$$

By indirect measurements  $K_s$  depending on the cracking degree of the measured surface can be determined.

$$K_s = g_s \cdot g_f \quad (5)$$

where:  $K_s$  = permeability coefficient on investigated surface;  $g_s$  = severity grade of the cracked surface;  $g_f$  = cracking grade of the cracked surface.

These parameters are interdependent.  $K_s$  can be determined by measurements performed in laboratory on reduced scale models. Depending on the cracking grade ( $g_f$ ) the severity grade of the cracked surface can be determined. For material types used in road pavements  $K_s$  are identified and observed according to the ( $g_f$ ) and ( $g_s$ ) and a grid of values can be determined for these two parameters.

#### 4 Permeability identification of a wearing course in use

Subsequently measurements on experimental sectors can be made, with the aim being that depending on the coefficients ( $g_f$ ) and ( $g_s$ ) determined by the field visual measurements to assess  $K_s$  as a quality parameter of the wearing course surface.

Quantitative determination of a cracked surface permeability through the permeability coefficient  $K_s$ , requires knowledge of a range of embedded parameters, as follows:

$$k_s = \frac{Q \cdot h \cdot d \cdot l}{S \cdot A \cdot t \cdot \Delta a} \text{ (mm.water column/s)} \quad (6)$$

where:  $Q$  = amount of water infiltrated;  $h$  = wearing course thickness;  $t$  = the measurement time;  $S$  = plane surface affected by crack;  $A$  = total surface of measurement;  $\Delta a$  = the pressure fall of the fluid column in the graduated tube  $\Delta a=35$  cm;  $d$  = average crack opening;  $l$  = crack length.

When road pavement is not cracked, permeability coefficient  $k_s^{(1)}$  is given by structural permeability (water infiltrated through the structural voids). When the pavement is cracked, permeability coefficient  $k_s^{(2)}$  is given by the structural permeability cumulated with water infiltration through the crack. From here one can calculate the cracked surface permeability index ( $I_c$ ) by reference to cracked surface:

$$I_F = \frac{k_s^{(2)} - k_s^{(1)}}{k_s^{(1)}} \cdot 100[\%] \quad (7)$$

#### 4.1 Field permeability measurement conducting

In this way an area with a developed cracking system is analyzed by comparison with one adjacent carriageway surface which is not cracked. The reduced scale device (Fig. 3a) designed for laboratory testing which has useful area of 187.2 cm<sup>2</sup>, will be extended as surface to the value of 6400 cm<sup>2</sup> (Fig. 3b). By expanding the measured surface by 37 times we aim to highlight the cracked surface, respectively identifying the cracking grade ( $g_p$ ). Thus, we first need to choose the measurement area for the representative cracked surface from the carriageway.

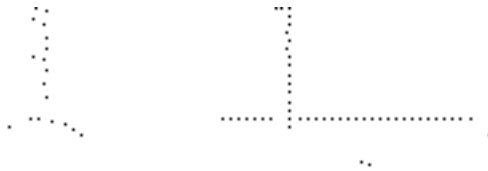

**Figure 3** Laboratory (a) and field (b) measurement devices

To highlight the field measurement procedure of the permeability index ( $i_p$ ), stages of investigation are presented successively through photographic images:

- laboratory measurement device compared to that intended for field measurements, according to the drawing shown in Fig. 3;
- measurement area delimitation (Figure 4, first photo);
- the mounting of the field device (Figure 4, second photo);
- selection of the measured surface I for comparison with the permeability of an uncracked surface II;
- measurement of crack affected area ( $S_1$ ) in relation to total uncracked area ( $S$ ).



**Figure 4** Surface marking; Sealing material application; Field device

After these operations what follows is the device laying on chosen 'footprint' and the performance of measurement of carriageway surface permeability (Figure 4). In figure 4 (third photo) an image with device vat and the graduated tube mounting is presented, as well as the reservoir and graduated tube filling to measure the infiltration time of a predetermined volume of water in the road surface.

## 4.2 Permeability field measurements results interpretation

Determine the area affected by cracks ( $S$  = total area covered by the measuring device of the field carriageway surface permeability,  $S_1$  = area affected by cracks in the surface  $s$ ), Figure 5. In this sense, one can interpret the permeability index of the cracked surface ( $I_p$ ), using the relationship between permeability coefficient ( $k_s$ ), cracking grade of the cracked surface ( $g_p$ ) and the severity grade of the cracked surface ( $g_s$ ), as follows:

$$I_p = g_s \cdot g_p \cdot \frac{k_s^{(2)} - k_s^{(1)}}{k_s^{(1)}} \quad (8)$$

where:  $k_s^{(1)}$  = uncracked surface permeability coefficient;  $k_s^{(2)}$  = cracked surface permeability coefficient. The cracking grade ( $g_p$ ) is determined on analyzed surface as ratio of area actually affected by cracks and the total area analyzed (0.8 x 0.8 mp). The severity grade ( $g_s$ ) of the cracking is determined according to the Standard AND 540 depending on the three stages.

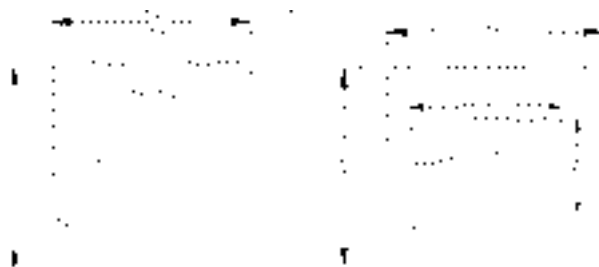

Figure 5 Cracked surface

Table 1 Severity grade

Severity grade	LOW	MODERATE	HIGH
Coefficient from AND 540	0.4	0.7	1.0

Coefficients were taken from the block cracking degradation type, considering the measuring area of device (0.8 x 0.8 mp). After the assessment, conditions to quantify the carriageway surface quality determined in laboratory, initially on the same type of road material, have changed, depending on effective permeability index (on field):

- $I_p \leq 0.2$  microcracked surface  
VERY GOOD impermeability
- $0.2 < I_p \leq 0.7$  cracked surface  
ACCEPTABLE impermeability
- $I_p > 0.7$  HARD-cracked surface  
BAD impermeability

In this situation the remedial measures of carriageway surface impermeability quality can be evaluated qualitatively as follows (Table 2):

**Table 2** Maintenance operations depending on the impermeability grade

---

For VERY GOOD impermeability – be kept under observation

---

For ACCEPTABLE impermeability – surface colmation

---

For BAD impermeability – be executed ultrathin layers to seal the surface

---

## 5 Research conclusions

At the procedural analysis level, the research of stated problem has revealed a qualitative methodology for the permeability evaluation of a wearing course, by means of a performance coefficient which represents the ratio between the permeability of the un-cracked surface versus the cracked one.

With this methodology, laboratory tests were performed on plates manufactured in the laboratory. From the results interpreted it can be observed that the evolution of permeability coefficient after a similar mathematical relationship with Darcy law varies proportionally with the water flow infiltrated in cracked layer. It has been observed that the permeability index ( $i_p$ ) increases with the growth of cracked surface.

Management systems require accurate data to support conclusions where and when to invest in maintenance, rehabilitation and road construction. In Romania, at this moment, the technical state analysis of the roads in service uses similar procedures as the U.S.A. program SHRP, which requires an assessment of technical condition indices on homogeneous road sectors, by observing the evolution of degradation state during exploitation of the road.

The permeability measuring method for road wearing course is in its research phase in Romania, whose technical regulations now condition only skid resistance and roughness as quality imposed to carriageway surface, thus minimizing the importance of wearing course impermeability.

## References

- [1] Technical University of Civil Engineering Bucharest: Impermeability quality determination of the carriageway surface through cracking grade of the wearing course, Phase B (2007), stage I (B.1) - Research Contract.





## EFFECTIVE ROAD MAINTENANCE WORKS PLANNING

Ján Mikolaj, Ľubomír Pepucha, Peter Časnocha, Ľuboš Remek  
*University of Žilina, Faculty of Civil Engineering,  
Department of Construction Management, Slovak Republic*

### Abstract

Systematic approach to the maintenance of road network section is a very important issue from the view of public costs. In a lot of countries Pavement management systems were developed based on various principles. The main goal is to ensure safety and continuity of road traffic. Article presents Pavement management system in Slovakia based on road construction diagnostics, traffic volume, climate factors and evaluation of maintenance works economics effectiveness by using of software tools like HDM-4 developed by World Bank.

### 1 Sustainable road maintenance in Slovak republic environment

Road administrators differ significantly with available budgeted, length of roads they are responsible for, demands put on their assets, demands put on acquisition of new assets and many other issues; yet their task is the same. Their task is to develop and maintain a safe, eco-friendly and efficient transport system.

#### 1.1 Road network of SR

The road network of Slovakia consists of 391 km of limited access roads (motorways and express roads) and 174 367 km of 1<sup>st</sup>, 2<sup>nd</sup> and 3<sup>rd</sup> class roads. The main objective of motorway network is to provide transit according to Pan-European transport corridors, namely the IV., v. and vi. corridor. The purpose of express road network is to collect and transfer the transport generated by Slovak republic's regions and contra wise to distribute transport from foreign countries from motorways to the body of Slovak Republic. The 1<sup>st</sup>, 2<sup>nd</sup> and 3<sup>rd</sup> class roads fulfill the service task of transportation between and within regions of Slovak republic. On top of this network a network of urban communications and minor purpose communication is connected. Different types of roads have different owners and administrators with their executive offices. Their general task is to securing a fluent and safe transport on them entrusted roads by providing maintenance, winter service, repair, reconstructions and acquisition of new assets according to concept of development of road network of Slovakia.



Figure 1 Composition of road network of Slovak republic.

This paper is aimed on the topic of road maintenance of low class road network (1<sup>st</sup> and 2<sup>nd</sup> roads) which constitutes the majority of the whole SR road network; therefore the viewpoint of administrators of this road network will be crucial.

### 1.2 Sustainable maintenance of a road network

The purpose of maintenance and repairs of asphalt pavements is to extend the useful life of the pavement, maintain a smooth riding surface, and prevent water from entering the underlying soil. Limited manpower and resources have increased the importance of maintenance and repairs to the life of a pavement. To keep a pavement in the best possible condition, it is important to use an effective pavement management system (PMS).

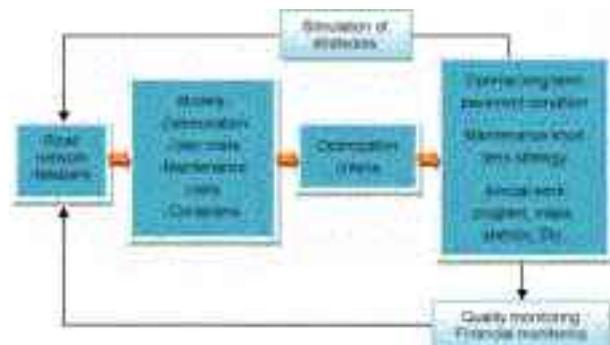

Figure 2 Basic PMS scheme

Pavement management system is a subsystem of asset management. It should ensure the right dividing of assigned funds coming from state budget and additional regional tax funds. These funds are very limited thus sustainability principles have to be implemented so the road network can provide the road users with socio–economical benefits. These boost the living standards of our society, which is then more prone to spending which means more taxation money.

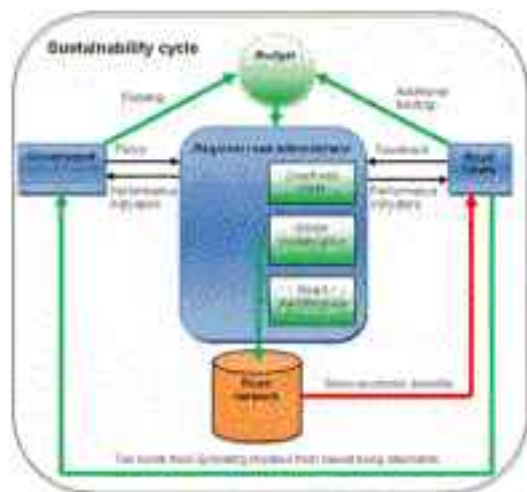

Figure 3 Principle of sustainability in road administration

From the economical viewpoint; the sustainability principle means to balance the spend funds with generated funds which again can be spend and so on in an infinite cycle.

## 2 Implementation of sustainable road maintenance in Slovak republic environment

At this time the ratio of pavement conditions on 2<sup>nd</sup> and 3<sup>rd</sup> class roads and the amount of accessible resources of road administrators of these networks begin to reach critical levels. While a complete effective road asset management even of motorways and 1<sup>st</sup> class roads is still far from completion a substitution solution have to be made to help road administrators of lower class roads. Since the 2<sup>nd</sup> and 3<sup>rd</sup> class roads aren't systematically surveyed and their state isn't stored and used as an input for PMS, the municipal administrators of these roads rely on fixed maintenance standard. The maintenance and repair procedures prescribed by fixed maintenance standard don't always correspond with the actual needs of the road conditions nor do they take into account the budget possibilities of the road administrator. It's merely an empirically based schedule of pavement treatment works which guarantees a good condition of the road throughout its whole life cycle. The downsides are obvious; the overall idea doesn't (mainly a high cost of this standard) correspond with the procedures described in asset management theory with all the impacts that fact has on effective road administration. Therefore a search for lower-cost maintenance standards and the process of assigning them to individual roads started as a part of research on University of Žilina. The aim is to assess the possibilities of cheaper maintenance while still providing a fair pavement quality to the society. This also means that instead of having part of road network maintained in sub-optimal and part in over-optimal condition, more homogenous ride quality on whole network will be achieved.

### 2.1 Maintenance standard chart

In the last part of research in our department we've assessed the suitability of lower-cost maintenance standards for lower class network.

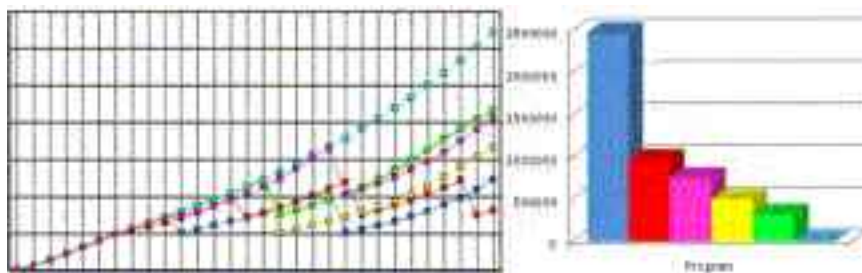

Figure 4 Maintenance standard effects and cost

Table 1 Maintenance overall ranking

Viewpoint	Variant 1	Variant 2	Variant 3	Variant 4	Variant 5	Variant 6
Cost	6th	5th	4th	3rd	2nd	1st
Technical suitability	1st	2nd	5th	3rd	4th	6th
Economical effectiveness	4th	5th	3rd	2nd	1st	6th
Overall	3rd	4th	5th	2nd	1st	6th



The results in fig 4 and table 1 show five alternate variants, each with different cost and effects on pavement conditions. The ranking is only for orientation. Apart from the technical suitability the results also underlie to these conclusion with account the technical issues of these proposals:

- Variant 1 – Current maintenance variant – Very expensive variant appropriate only for very burdened road sections.
- Variant 2 – microsurfacing based variant – safe to use on all 2<sup>nd</sup> and 3<sup>rd</sup> road class roads.
- Variant 3 – balanced cover layer exchange based variant – may be appropriate even for 2<sup>nd</sup> class roads with traffic load under 1000 AADT especially if they aren't suffering excessive high load vehicles encumbrance.
- Variant 4 – one major cover layer exchange based variant – fairly safe to use on all 2<sup>nd</sup> and 3<sup>rd</sup> road class roads.
- Variant 5 – one microsurface based variant – may be appropriate even for 2<sup>nd</sup> class roads with traffic load under 1000 AADT especially if they aren't suffering excessive high load vehicles encumbrance.
- Variant 6 – basic variant – is appropriate only for 3<sup>rd</sup> class roads which doesn't exceed the 1000 AADT limit and/or aren't suffering excessive high load vehicles encumbrance.

**Table 2** Maintenance standard effects, NPV and IRR (economic effectiveness ranking)

	Name	Description	Costs	NPV	IRR
1	Current maintenance standard	5, 15 and 25 <sup>th</sup> year 25mm microsurfacing with 10 and 20 <sup>th</sup> year surfacing replacement.	2 480 085	1 691 695	13.9
2	Basic variant	Whole lifetime of only basic surface treatment.	2 643	0	0
3	Microsurfacing based variant	Basic surface treatment with 25mm microsurfacing in 7 <sup>th</sup> 16 <sup>th</sup> and 25 <sup>th</sup> year.	977 588	1 723 229	12.1
4	One major cover layer exchange based variant	Basic surface treatment with 40mm cover layer exchange in 14 <sup>th</sup> year	502 654	2 045 110	30.9
5	One microsurface based variant	Basic surface treatment with 25mm microsurfacing in 14 <sup>th</sup> year.	327 279	1 588 528	37.9
6	Balanced cover layer exchange based variant	Basic surface treatment with 20mm cover layer exchange and 25mm microsurfacing in 8 <sup>th</sup> 18 <sup>th</sup> and 28 <sup>th</sup> year.	760 652	1 236 838	15.6

The cost ranking is pretty self-explanatory; more interesting is the economical effectiveness ranking. It may seem tempting to always predict that the most economically effective standard is always the best choice. While it's clearly something that common sense says its right, one aspect shouldn't be neglected.

From the viewpoint of sustainable asset management a salvage value of assessed construction has to be considered. Residual or salvage value could be defined as an estimated value asset's worth that can be obtained from it after its useful life has ended. From this viewpoint we can add salvage value as another factor which influences the ranking of these maintenance standards. The impact this assumption is shown in table 3.

**Table 3** Modified overall ranking of maintenance standards

Viewpoint	Variant 1	Variant 2	Variant 3	Variant 4	Variant 5	Variant 6
Cost	6th	5th	4th	3rd	2nd	1st
Technical suitability	1st	2nd	5th	3rd	4th	6th
Economical effectiveness	4th	5th	3rd	2nd	1st	6th
Salvage value	2nd	1st	4th	3rd	5th	6th
Overall	3rd	4th	5th	1st	2nd	6th

It's important to address the issues which arise with this step:

- 1 What if assessed roads sections don't have an initial starting IRI value?
- 2 Is IRI really the sole factor which influences the salvage value of an road section?

To answer first question; from a very simplified viewpoint we could add the actual IRI value to the value of IRI at the end of the road's life but since the roughness deterioration isn't linear, there will be a minor deviation which will get bigger as the starting IRI of a assessed road will be. Therefore we advise to take the salvage value factor in account only on roads which IRI doesn't exceeds 2.5 and add their actual IRI value to IRI at the end of the road's life.

To answer the second question, we did an experiment described in the next chapter.

### 3 IRI as a factors influencing operating speed of vehicles

As we know there are several factor influencing economical effectiveness of road maintenance and repair works. It's mainly the difference between technical parameters of maintained and unmaintained road generating socio-economic benefits for road users and the investment costs of these works. Since repair and maintenance works don't change the fixed technical parameters like geometrical alignments or width of communication; it's the variable parameters which changes are bearing the weight of generating the benefits. It's assumed that the main variable parameter is the IRI (International Roughness Index) which usually is the main indicator of road surface condition. To prove this assumption we did an experiment in HDM-4 to show the influence IRI has on vehicle operating speed which change is the main indicator of road user benefits. We then transformed known mathematical equations used to calculate operating speed in relation to IRI to better suit the environment of 2nd and 3rd road network of Slovak Republic.

#### 3.1 IRI as a factors influencing operating speed of vehicles

For this experiment first a straight and level road section was created. Very loose traffic intensity (1000 AADT) was set and the operating speed was calculated for different IRI ranging from 1 to 12 on this road. We've run the test both in urban and un-urban environment for private cars and lorries.

As an alternative a geometrically curvy variation of this road was made (resembling a typical alignment for lower class road section in SR environment). This way we could examine the speed difference between two different alignments to estimate the impact of curvature of the road. The third run raised the loose 1000 AADT traffic intensity to a 10000AADT.

The results shown in fig 5 showing that at low class road, neither the alignment nor intensity plays a marginal role in vehicle speed reduction. The mayor difference makes the IRI. The full results are shown in tabular format in table 4.

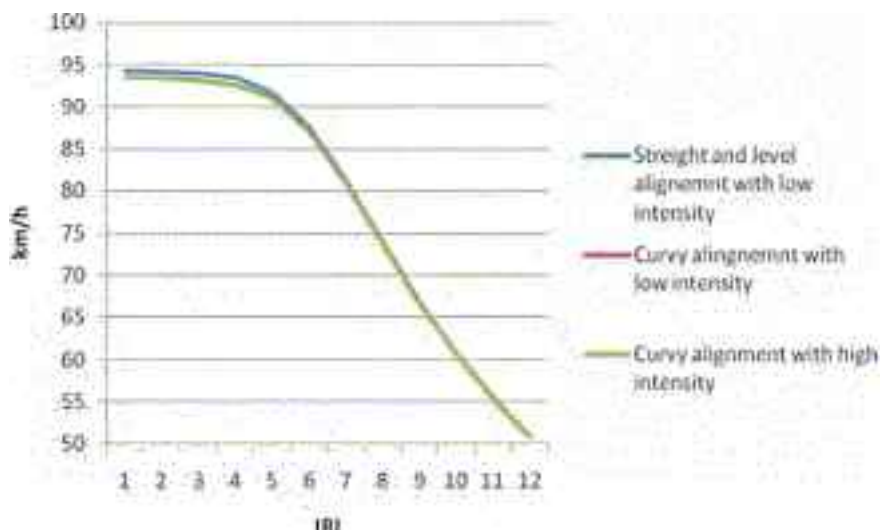

Figure 5 Operating speed depending on IRI

With the result in mind we draw the conclusion that IRI truly is the most important factor when it comes down to vehicle operating speeds. That also means that maintenance standard that keeps the road at the end of its life cycle with the lowest IRI keeps the road also with the biggest salvage value. Therefore when assessing the feasibility of maintenance standards for a road section the salvageable value of that road section it's recommended to take into account.

Table 4 Vehicle operating speed (km/h) depending on IRI (PC=personal car, L=lorrie; NU=non-urban, U=urban environment)

Condi- tions	Car category	Envir- onment	IRI											
			1	2	3	4	5	6	7	8	9	10	11	12
Straight and level alignment with low intensity	PC	NU	94.2	94.1	94	93.4	91.7	87.6	81.2	73.8	66.8	60.6	55.3	50.8
		U	54	54	54	54	53.9	53.9	53.7	53.2	52.4	51.1	49.3	47.1
	L	NU	86.2	86.1	86	85.7	84.7	81.3	74.6	66.9	60	54.1	49.3	45.2
		U	54	54	54	54	54	53.9	53.8	53.3	52.2	50.1	47.4	44.3
Curvy alignment with low intensity	PC	NU	93.5	93.4	93.2	92.7	91	87.1	80.9	73.7	66.7	60.6	55.3	50.8
		U	54	54	54	54	53.9	53.8	53.6	53.2	52.4	51.1	49.3	47.1
	L	NU	84.7	84.6	84.4	84.2	83.3	80.2	74.1	66.7	59.9	54.1	49.3	45.2
		U	54	54	54	54	54	53.9	53.8	53.3	52.1	45.2	47.4	44.3
Curvy alignment with high intensity	PC	NU	93.5	93.4	93.2	92.7	91	87.1	80.8	73.6	66.7	60.6	55.3	50.8
		U	54	54	54	54	53.9	53.8	53.6	53.2	52.4	51.1	49.3	47.1
	L	NU	84.7	84.6	84.4	84.2	83.3	80.2	74.1	66.7	59.9	54.1	49.2	45.2
		U	54	54	94	54	54	53.9	53.8	53.3	52.1	50.1	47.3	44.3

## Acknowledgements

This contribution is the result of the project implementation: 'Independent Research of Civil Engineering Construction for Increase in Construction Elements Effectiveness' (ITMS: 26220220112) supported by the Research & Development Operational Programme funded by the ERDF.

'This work was supported by the Slovak Research and Development Agency under the contract No. LPP-0402-09'.

## References

- [1] Mikolaj, J., Trojanova, M. & Pepucha, L.: Global Trends on Road Administration based on Asset Management, IFME 2012 Helsinki Congress 2012.
- [2] Mikolaj, J., Trojanova, M. & Pepucha, L.: Sustainable Maintenance in Road Administration Based on Asset Management, 4th European pavement and asset management conference 2012.
- [3] Mikolaj, J., Valuch M.: Pavement Management System in Slovakia, theoretical aspects, practical experiences, st European pavement management system conference : proceedings. - Budapest : 2000..





## MICRO–SURFACING ON FRENCH HIGHWAYS: RECENT SUCCESSFUL EXPERIENCES

Jean–Etienne Urbain<sup>1</sup>, Mario Medved<sup>2</sup>, Eric Layerle<sup>1</sup>, Ivan Kolarić<sup>2</sup>

<sup>1</sup> Eurovia, France

<sup>2</sup> Tegra, Croatia

### Abstract

The majority of the maintenance works on high traffic roads are based on hot or warm bituminous products, this kind of traditional products offer all the properties required for wearing course issues. Micro–surfacing is right now at the margins of this type of works. Nevertheless, this technique has already been designed, studied and implemented on highways in the past.

Answering totally the objectives of the project owner, micro–surfacing has been laid recently on French highway section. The product chosen for these maintenance works was the GRIPFIBRE<sup>®</sup>, a micro–surfacing product adapted to high traffics.

The follow up indicates that the GRIPFIBRE<sup>®</sup> applied in 2007 on A87 motorway (near Cholet) has kept very good properties of skid resistance. Measurements have been performed concerning macrotexture (ATD through sand patches test) and microtexture (through friction coefficient). The values of the sideways force coefficient indeed stabilize around 0.63 in both directions after 4 years (measurements done in 2011).

The 4 years follow–up on A87 shows that the good level of skid resistance is long–lasting and sustainable over time, which proves the good mechanical behavior of the product under very high traffic. In comparison with a traditional solution of maintenance work with VTAC 0/10 (Very Thin Asphalt Concrete called BBTM in France), the technique micro–surfacing thus allows, among others:

- A reduction of 62 % of the transport of aggregates,
- A decrease of 182 tons of greenhouse gases representing – 63 %,
- An economy of 3 330 tons of aggregates, which means 59 % of saved natural resources.

The low environmental impact of GRIPFIBRE<sup>®</sup>, a cold technique produced on site hence reducing transport and saving materials, is an obvious additional advantage.

*Keywords: maintenance, surface characteristics, safety, low environmental impact*

### 1 Introduction

The maintenance of motorway wearing course is very important to guarantee user safety and comfort. Most maintenance works on heavy traffic pavements rely on a wide range of hot or warm mix asphalt materials able to cover all wearing course functions: skid resistance, waterproofing, drainage, evenness, rolling noise, etc. But micro–surfacing also has good characteristics and that is why this process can be used instead of asphalt mixes.

Micro–surfacing has been laid on one highway section, answering the owner's targets. GRIPFIBRE<sup>®</sup> process, an adapted micro–surfacing technique for the high traffic, has been used for maintenance works. It has an advantageous environmental impact and a very good level of skid resistance proved by the measurements which have been performed on this product to estimate the macrotexture and microtexture over time.

## 2 GRIPFIBRE®

GRIPFIBRE® process is a micro-surfacing with gap-graded or continuous grading curve, associating a bitumen emulsion often modified by polymer and organics fibers. A picture of this process is shown on Fig. 1.



Figure 1 Fibers used in GRIPFIBRE® mix design

During the summer 1998, a section of 2 kilometers of the A71 has been realized for maintenance works with GRIPFIBRE® o/10. Some measurements of braking force coefficient have been performed after 6 and 18 months of service. The results are shown on Fig. 2.

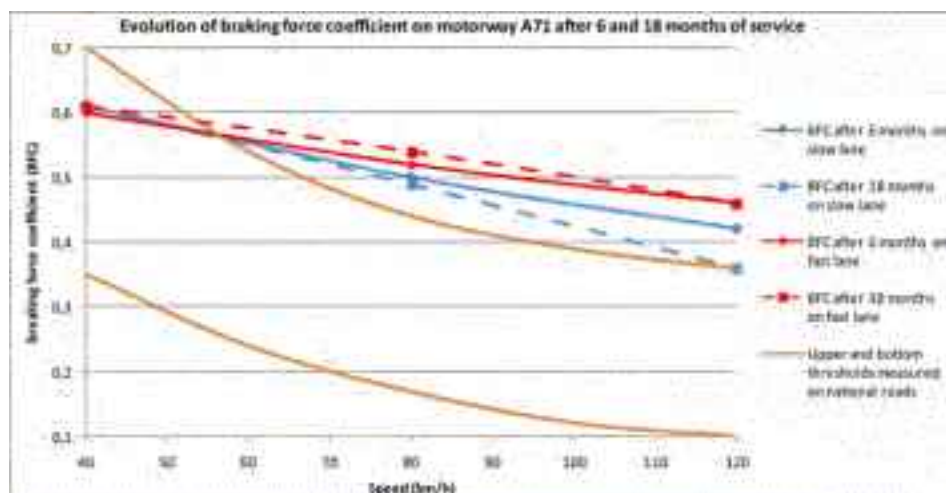

Figure 2 Evolution of braking force coefficient on motorway A71

At the early stage, GRIPFIBRE® has braking force coefficient values located at the top of the upper threshold for national roads. After 18 months the braking force coefficient stays at a high level. The conclusion of the Regional Laboratory (CETE), who had performed the measurement, was: 'the skid resistance level measured on A71 motorway remains at an excellent level after 18 months'.

### 3 A87 construction site

#### 3.1 Characteristics of the construction site

The works section is located between Cholet North and Cholet South exits on the A87 highway. The works took place from 10 to 20 September 2007 and were realized by a special team of Eurovia South–West. The road bears a heavy traffic T1 with 500 trucks per day and the support layer was composed of a semi–coarse asphaltic concrete applied in 2000. Choice was made to use dual layers application 0/4 and 0/10 continuous grading. The first layer is composed of 0/4 grading with a bitumen emulsion modified by polymer. The second layer contains 0/10 grading with fibers to facilitate the laying of the product; moreover these fibers avoid segregation. The use of fibers allows GRIPFIBRE® to get an improved ageing resistance.

##### 3.1.1 Mix design

The mix design of the micro–surfacing has been realized by the regional laboratory of the South–West technical delegation, it is detailed in Table 1. These two mix design have been tested according to the interne Eurovia method and the results are shown on Table 2.

**Table 1** Mix design of dual–layer micro–surfacing used on motorway A87

Formula	Microsurfacing 0/4 Pont Charron/Meilleraie		Microsurfacing 0/10 c Pont Charron	
Composition	0/4 Pont Charron	60%	0/2 Pont Charron	40%
	2/4 La Meilleraie	40%	2/6 Pont Charron	40%
			6/10 Pont Charron	20%
Hydrated lime (ppc)	0.5		Hydrated lime (ppc)	0.5
Fibers (ppc)	-		Fibers (ppc)	0.07
Added water (ppc)	11		Added water (ppc)	10
PmB Emulsion (ppc)	11.8		PmB Emulsion (ppc)	10.8
Residual binder (ppc)	7.1		Residual binder (ppc)	6.48
Maximum density (t/m3)	2.638		Maximum density (t/m3)	2.683
Binder modulus	4.54		Binder modulus	4.24

**Table 2** Test conducted on motorway A87 on dual–layer micro surfacing

	Standard	Unit	Specifications	Micro-surfacing 0/4	Micro-surfacing 0/10 c
Working time	MEI				
Workability time		s	≥ 90	90	110
Breaking time		min	≤ 20	4	4
Benedict cohesion	NF EN 12274-4				
Cohesion at 30 min		kg.cm	≥ 20	23	23
Cohesion at 60 min		kg.cm	≥ 23	24	24
Abrasion WTAT	MEI				
Weight loss (T = 18°C, HR=55%)		%	≤ 5	-	0
Weight loss (T = 18°C, HR=100%)		%	≤ 25	-	2



### 3.1.2 Laying

Production controls have been carried out during the construction site with a minimal frequency of 1 control per day. The results have confirmed the perfect control of the production of the micro-surfacing. The works have been carried out in 6 days and a half. The road surface coated was around 117 300 m<sup>2</sup> in other word 234 600 m<sup>2</sup> of micro-surfacing. The daily cadence has reached 36 000 m<sup>2</sup>. The laying speed varies between 1.5 and 2.5 km/h for a width of 3.8 m.

The technique of micro-surfacing allows reaching of a high laying rate; that is very appreciated on highway construction site.

### 3.2 Monitoring of surface characteristics over time

The A87 site has been monitored over the time by ASF and Eurovia.

ASF has used the equipment SCRIM<sup>®</sup> (Sideway force Coefficient Routine Investigation Machine) to measure the texture depth and the sideway force coefficient after 1 and 4 years of service. Eurovia has realized the measurement of the average texture depth in October 2008 (sand patches), in slow lane (Table 3).

After the first summer, GRIPFIBRE<sup>®</sup> had kept its high macrotexture over the time. The behaviour over the time after 1 year is appreciated by the ASF's values which are shown in Table 4.

**Table 3** Monitoring of macrotexture after one year

		Average texture depth	
		Sand patch values	Standard deviation
October 2008	Direction 1 : From Paris to la Roche-sur-Yon	1.15 mm	0.05 mm
	Direction 2 : From La Roche-sur-Yon to Paris	1.1 mm	0.08 mm

**Table 4** Monitoring of macrotexture after one year and four years

		Average texture depth	
		Average	Standard deviation
June 2008	Direction 1 : From Paris to La Roche-sur-Yon	1.3 mm	0.11 mm
	Direction 2 : From La-Roche-sur-Yon to Paris	1.2 mm	0.13 mm
June 2011	Direction 1 : From Paris to La Roche-sur-Yon	1.0 mm	0.10 mm
	Direction 2 : From La-Roche-sur-Yon to Paris	1.0 mm	0.15 mm

The two tables show a good correlation between the two measurements. After 4 years, a weak erosion occurs but it remains homogeneous in the two directions. The average values of 1 mm after 4 years of service prove that the mosaic is well established and that the macrotexture is stabilized at a high level.

The sideway force coefficient has been measured by the SCRIM<sup>®</sup> device and the results are given in Table 5.

**Table 5** Monitoring of sideways force coefficient after 1 and 4 years

		Sideways force coefficient	
		Average	Standard deviation
June 2008	Direction 1 : From Paris to La Roche-sur-Yon	0.71	0.02
	Direction 2 : From La-Roche-sur-Yon to Paris	0.66	0.02
June 2011	Direction 1 : From Paris to La Roche-sur-Yon	0.63	0.02
	Direction 2 : From La-Roche-sur-Yon to Paris	0.63	0.02

These values are calculated on 400 measurements, so it is interesting to analyze the distribution of the results under the form of distribution histograms after 1 and 4 years of service in the two directions. (Fig. 3 & 4)



**Figure 3** Evolution of skid resistance on motorway A87 – Direction 1



**Figure 4** Evolution of skid resistance on motorway A87 – Direction 2

These histograms show that GRIPFIBRE® keeps very good properties of skid resistance after 4 years. In both directions the skid force resistance values are stabilized at 0.63. Moreover, used aggregates have a middle PSV value of 52. After a visual check, no problem was listed. The performance class of this micro-surfacing is the best: VDA 1 (class 1 of the Visual Defect

Assessment according to the European standard EN 12273). The good homogeneity of micro-texture after one year of service is illustrated on Fig. 5.



Figure 5 Surface aspect of micro-surfacing after one year of service











## 4 Environmental impact

An environmental comparison is established between dual layer micro-surfacing 0/4 – 0/10 and a very thin asphalt concrete overlay 0/10: the dual layer micro-surfacing has a lot of advantages environmentally speaking. To highlight this difference, the eco-comparator GAIA.be<sup>®</sup> software was used, in considering the furniture, the fabrication in mixing plant, the transport and the laying. The conditions of the construction site are a surface of 120,000 m<sup>2</sup> and a distance of 20 km with the mixing plant. (Table 6)

Compared with a very thin asphalt concrete overlay 0/10 ('base'), the micro-surfacing ('proposition') offers, among other things:

- A reduction of 62 % of the transport of materials
- An economy of 182 tons of greenhouse gas, corresponding to – 63 %
- A reduction of 3,330 tons of aggregates, corresponding to 59 % of saved natural materials

Table 6 Environmental impact of micro surfacing solution

Environmental indicator	Difference		100%
	Absolute value	%	
Depletion of resources (ADP) (kg eq Sb)	-4,579	-55%	
Aggregate consumption (Tonnes)	-3,330	-59%	
Energy resources consumption (MJ)	-2,889,790	-62%	
Direct fuel oil consumption (liters)	-61,909	-80%	
Overall transport (Tonnes km)	-478,754	-62%	
Emission of GHG climate change (kg eq CO2)	-182,444	-63%	
Atmospheric acidification (kg SO2 eq)	-1,932	-69%	
Air pollution (m3)	-21,720,265	-70%	
Water pollution (m3)	-100,543	-61%	
Photochemical ozone creation ozone (kg eq Eth)	-205	-67%	

## 5 Conclusion

Recently, GRIPFIBRE product was applied on sections of highway with high traffic levels (motorway A87). This technique meets the needs of high laying rates and restoration of an excellent level of skid resistance, vector of safety. Besides, the speed of execution limits the embarrassment to the traffic and the exposure of the staff in the dangerousness of the circulation.

The monitoring during 4 years shows that the level of skid resistance is sustainable in the time, which proves the good mechanical behaviour of the product under very high traffic.

The low environmental impact of this 'cold technique' product in terms of transport reduction and materials savings, is besides an obvious additional advantage.



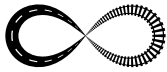

## ON A NOVEL OPTIMISATION MODEL AND SOLUTION METHOD FOR TACTICAL RAILWAY MAINTENANCE PLANNING

Franziska Heinicke<sup>1</sup>, Axel Simroth<sup>1</sup>, Roberto Tadei<sup>2</sup>

*1 Fraunhofer Institute for Transportation and Infrastructure Systems IVI, Germany*

*2 DAUIN–Department of Control and Computer Engineering, Politecnico di Torino, Italy*

### Abstract

Within the ACEM–Rail project of the European Seventh Framework Programme new measurement and inspection techniques for monitoring the track condition are developed. By means of these new techniques the prediction of future track condition will be highly improved. To our knowledge mid–term maintenance planning is done for projects and preventive tasks, but predictions of the track condition are not incorporated into the planning process up to now. To efficiently utilise this new kind of information one task within the ACEM–Rail project is the development of methods for planning predictive maintenance tasks along with preventive and corrective ones in a mid–term planning horizon. The scope of the mid–term or tactical maintenance planning is the selection and combination of tasks and the allocation of tasks to time intervals where they will be executed. Thereby a coarse maintenance plan is determined that defines which tasks are combined together to form greater tasks as well as the time intervals for executing the selected tasks. This tactical plan serves as the base for booking future track possessions and for scheduling the maintenance tasks in detail.

In this paper an algorithmic approach is presented which is able to react on dynamic and uncertain changes due to any track prediction updating. To this end optimisation algorithms are implemented within a rolling planning process, so it is possible to respond to updated information on track condition by adapting the tactical plan. A novel optimisation method is developed to generate cost effective and robust solutions by looking ahead into the future and evaluating different solutions in several scenarios.

*Keywords: railway maintenance, tactical planning, optimisation under uncertainties*

### 1 Introduction

Tactical planning is an important step in the process of planning railway maintenance activities. It involves the selection and combination of maintenance tasks and their allocation to time intervals ('slots') where they will be executed. As a side–effect the tactical plan impacts track possession booking. Tactical planning is done in a mid–term horizon, typically for nine to twelve months. Nobody knows the real track condition evolving within this period of time, only predictions can be made. Of course, these predictions are always afflicted with uncertainties. So uncertain predictions are the input to the tactical planning, which lead to probabilities for different track conditions (or level of severities) over time.

In this paper we present a novel optimisation model for tactical planning along with a solution method dealing with uncertain track conditions. The main idea of our approach is to create maintenance plans by periodic adaption and extension of the previous plan. Thereby booked track possession leads to a fixation of maintenance activities to time slots. Non–fixed activities can be shifted to other slots, if it is feasible and beneficial. In this way the planning

process is able to react on new situations, resulting from new track measurement data and predictions, and rectify uncertainties. Moreover, the algorithm takes a look into the future by simulating different future scenarios. This leads to a robust solution, mainly to a robust track possession booking.

Only a limited number of works can be found dealing with tactical maintenance planning. In [1] the Preventive Maintenance Scheduling Problem (PMSP) is defined and solved using simple heuristics. The PMSP is focused on preventive and periodically executed maintenance tasks and larger projects, whilst predictive maintenance activities are not considered. In [2] a method of constructing a four-week, cyclic, preventive maintenance schedule is described. Aim of the schedule is to handle the dictate to close the track for all trains during maintenance.

## 2 Modelling of tactical planning process and uncertainties

In this section we describe our approach to the tactical railway maintenance planning under uncertain track conditions. In 2.1 the concept of maintenance warnings will be introduced, while 2.2 describes the tactical planning process.

### 2.1 Warnings

In our model we refer to predictive or corrective maintenance activities that are generated based on the actual or predicted track condition as 'warnings'. The challenge in tactical planning is to combine or divide warnings and allocate the corresponding tasks to time slots, thereby fulfilling given constraints. The resulting allocation aims to be cost effective and robust to uncertain future conditions, as the plan is the base for booking track possession and executing maintenance tasks in short term.

Warnings are created in a preliminary step by the Maintenance Management System based on track measurement data and predicted conditions. We distinguish three kinds: basic, combined, and divided warnings. For each problem on the track all possible kinds of warnings are generated and in the planning process exactly one of them is selected. Normally basic warnings can be executed during one night by one team. Sometimes there is a possibility to combine the basic warnings of different problems on consecutive track sections to get one great combined warning. For combined warnings the track has to be closed longer than one night because of the long working duration. Hence additional costs for booking the track are incurred. On the other hand, the maintenance team has to travel only once to the track section which leads to lower travel costs. Another possibility is to divide a basic warning into smaller parts, resulting in so-called divided warnings that can be resolved manually. Mostly manual resolving is very time intensive but the machineries used are smaller and cheaper. Sometimes thus it is cost effective to resolve a warning by a set of manual activities.

Warnings are characterised in terms of degradation levels. For that purpose, the track condition is classified based on several parameters, e.g. geometric data. From the continuous spectrum of these parameters a discretisation into a small set of degradation levels is done. At a certain point of time a warning is at a specific degradation level. In one degradation level a certain maintenance task is necessary. Hence costs and resource requirements to resolve the warning in this degradation level are known.

From the track measurement data the current degradation level can be derived. Based on expertise and historical data a prediction for the future conditions is done by a novel predictive tool (also developed within the ACEM-Rail project). Results of this tool are the parameters of the stochastic model which are used to simulate the transition between different degradation levels. For the simulation of possible future scenarios – on which our solution approach is based on – transition probabilities are required. Therewith the development of the track condition is simulated and the influence of allocation decisions can be estimated. Furthermore, these probabilities can be used to calculate the distribution of the degradation levels

in the next time slots, and with it to derive expected costs, expected resource requirements, and other expected values for estimating the severity of a warning. In the current state of the project the prediction tool is still in a development stage. To test our optimisation approach, a Markov chain is used as the stochastic model for degradation levels with transition probabilities from railway expertise.

## 2.2 The tactical planning process

The aim of the tactical planning is to select one of the kinds of warning (basic, combined, or divided) for each predicted or existing problem on the track, and to plan the time for resolving the selected warnings in a coarse way by allocating to a time slot.

In tactical planning different aims have to be considered:

- Costs: resolve warnings by cost effective resource utilisation
- Flexibility: create a plan that can react on uncertain future developments
- Safety: resolve warnings before track enters critical conditions

Some of these aims are conflicting. For instance, a plan that resolves more warnings is more expensive. Contrariwise a low-cost plan defers more warnings and possibly resolves some of them not before a critical deterioration stage enters. To generate flexible plans track possession has to be avoided as far as possible, because track possession booking leads to a fixation of warnings and therewith to a limitation of the ability to react on future development. Sometime this leads to more cost intensive plans due to higher travel costs.

The tactical planning process is divided into two steps. At first the kind of warning (basic, combined, or divided) is selected for each problem. In the second step the chosen warnings are allocated to time slots where they will be resolved. This allocation is modelled as a Generalised Assignment Problem (GAP) [3] with stochastic costs and resource requirement. The challenge of the GAP is to find a minimum cost assignment of a set of items to a set of bins such that each item is allocated to exactly one bin. Thereby each item incurs individual costs and weights for each bin. Each bin has a given weight capacity, and the sum of the item weights of each bin must not exceed the bin capacity.

In order to model tactical planning as a GAP the planning horizon is subdivided into time slots (e.g. months or weeks) that represent the bins. The bin capacities are given by the limited resources of the time slot (e.g. hours of manpower, machine hours). The chosen warnings form the items. They have different costs and weights (resource requirements) in each time slot, resulting from the expected costs and resources calculated from the costs and resource requirement of the degradation levels and their probabilities.

Tactical planning is modelled as rolling process. After a given time period  $t_a$  the current plan will be adapted due to the development of track condition (progressive deterioration and occurring new problems) and extended by  $t_a$  to get a new plan covering the whole planning horizon.



### 3 Solution approach: the Monte–Carlo Rollout method

Before explaining our general approach for optimisation under uncertainties – the Monte–Carlo Rollout method – and its application to the tactical railway maintenance planning, we give a heuristic solution method to the problem. Applying this heuristic already yields to significant effects compared to conventional approaches that ignore the uncertainties in tactical planning.

#### 3.1 A Heuristic Solution method

To solve the tactical planning problem under uncertainties but without looking into the future we developed a basic heuristic  $\mathcal{H}$ . Solving the tactical planning problem means to regularly adapt and extend the plan of the previous planning period to the new situation.

In  $\mathcal{H}$  for each problem on the track the kind of warning is chosen that incurs the lowest average expected cost. Then within the allocation step it will be checked if it is beneficial to reallocate warnings which was planned in the last planning period, e.g. when the track deterioration was unforeseen or when the time slot exceeds the capacity limit. Warnings concerned are removed from the time slot and set as unallocated. Afterwards unallocated warnings are ordered by a priority which considers the increase of expected costs over time and a risk factor. At last the warnings are allocated to the earliest feasible time slot according to this priority. If no feasible time slot exists, the warning stays unallocated and will be deferred to the next planning horizon.

#### 3.2 Monte–Carlo Rollout: basic concept

The Monte–Carlo Rollout (MC–RO) approach combines ideas from Rollout algorithms [4] for combinatorial optimisation and the Monte–Carlo Tree Search [5] in game theory. Basic elements of the MC–RO method are a simple heuristic  $\mathcal{H}$  that is capable to generate 'good' solutions to the given problem based on current information, and a stochastic model for simulating the future uncertainties. Both are combined to take a look into the future and to estimate the future effects of current decisions.

The MC–RO method works as follows: Initially a set of different alternative solutions is generated. Each of these alternatives is proven and evaluated by a number of Monte–Carlo rollouts. In each rollout another future scenario is 'played' in terms of a two–player game. Thereby the stochastic model is used to simulate random events (moves of the 'random player'), and the changed situation is solved using the base heuristic  $\mathcal{H}$  (moves of the 'decision maker'). The two players move alternative until the end of the game or a predefined number of steps (the 'depth') is reached. The outcome of each scenario is evaluated, and the solution quality of the alternative is determined, e.g. by averaging scenario evaluations. After all the best alternative is chosen, being a high–quality solution additionally equipped with high robustness.

#### 3.3 Application of MC–RO to the tactical planning problem

In the tactical planning process the MC–RO approach is used to compare different tactical plans. Each plan is an adaption and extension of the current plan according to the new information on the track condition. By simulating different future developments of the track condition (using the stochastic model over degradation levels) the future influence of the decision is evaluated and the ability to react on different new situations is proven.

To generate the different plans we use a procedure that focusses on the selection of the kind of warning for each problem. Using the heuristic  $\mathcal{H}$  the kind of warning with the lowest average costs is chosen, in contrast by generating the alternatives in the MC–RO the kind of warning is chosen randomly. In doing so, the probability of the kinds depends on average

expected costs, high costs leading to a low probability. Hence sometimes more expensive kind of warning is chosen, but possibly less time intensive or more flexible in planning. All chosen warnings are allocated to the time slots as described in  $\mathcal{H}$ . In this way 25 different plans are generated. In practise this number could be increased, but in our first experiments this number showed a good trade-off between computational effort and effect of the MC-RO. In our experiments, each alternative plan is proven and evaluated with 100 Monte-Carlo rollouts. Each rollout is played as a two-player game as described above. At first the random player has to move: A possible scenario for the track condition after time period  $t_a$  is generated randomly. This consists in removing all resolved warnings and randomly simulating the track condition reached after time period  $t_a$  based on the transition probabilities for degradation levels. With it the distribution of degradation levels and expected values of costs and resources have to be recalculated. At last new warnings that are supposed to occur are created randomly and added to the set of unallocated warnings. Then it is the decision maker's turn: The plan has to be adapted and extended according to the new situation. This is done by applying the base heuristic  $\mathcal{H}$  to the new situation. Now the random player moves again and generates a possible scenario of the track after time period  $2 \cdot t_a$ . In this way the random player and the decision maker move alternatively until a given depth, we used 12 months in our experiments.

## 4 First results

The development of our solution approach for tactical planning is still ongoing. In this section we show first results regarding the evaluation function. As described above tactical planning has different competing aims (costs, flexibility and safety), leading to a multi-objective optimisation problem. There are different methods to handle such problems [6]: the  $\epsilon$ -Constraint method, goal programming, lexicographical order, and weighted sums.

Here three objectives have to be considered:

- C: the costs of the allocated warnings incurred (and predicted)
- I: the frequency of infeasibility
- U: the expected costs of unallocated (and deferred) warnings

All objectives have to be minimised. The costs incurred  $C$  are the costs paid for maintenance during the simulation. The frequency of infeasibility  $I$  is a measure for the flexibility of the plan, and by means of the expected costs for the unallocated (and deferred) warnings, we aim to express the safety aspect.

In our implementation the alternatives are tested one by one and compared with the best alternative  $b$  up to now which has the evaluation values  $C_b$ ,  $I_b$  and  $U_b$  (the initial best alternative is the heuristic solution). We say that alternative  $j$  (with  $C_j$ ,  $I_j$  and  $U_j$ ) dominates alternative  $b$ , if  $I_j \leq I_b$ ,  $C_j < C_b$  and  $U_j \leq U_b \cdot (1 + \alpha)$  where  $\alpha$  is a parameter. The dominating alternative is served as the best alternative  $b$ .

In our first calculation we prove the influence of  $\alpha$  in three different instances by simulating the track deterioration of three years 50 times. Each simulation is solved with the heuristic  $\mathcal{H}$  and the MC-RO method. For each instance three graphs are showed to illustrate the improvement of the MC-RO method compared to the heuristic solution. The first graph shows the improvement in the costs incurred  $C$  and the second the improvement in the average expected costs for unallocated (and deferred) warnings  $U$ . The improvements in infeasibility are not shown, because for the heuristic infeasible plans are rarely (under 0.5% in each instance) and for the MC-RO method all plans are feasible. Instead, the third graph shows the development of the unallocated warning rate over time.

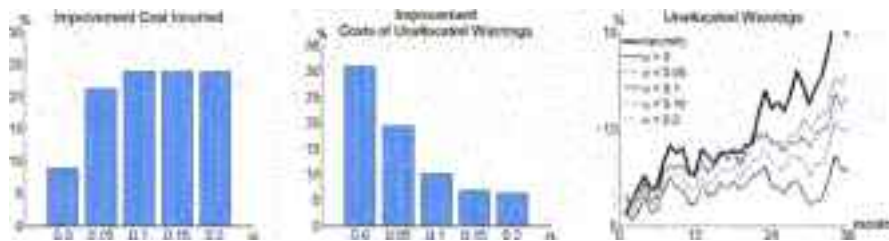

Figure 1 Results of Instance A

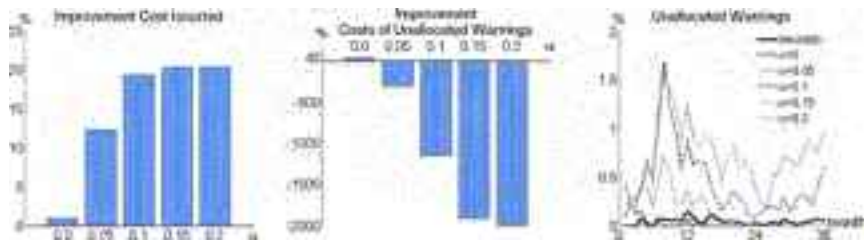

Figure 2 Results of Instance B

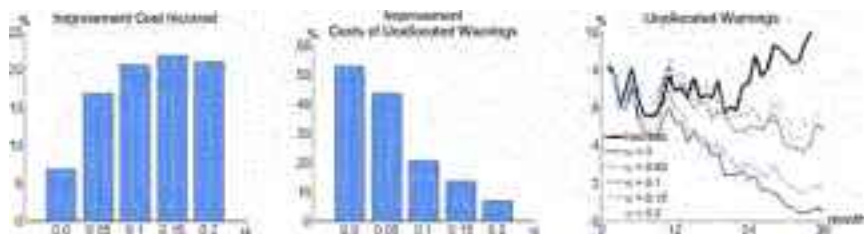

Figure 3 Results of Instance C

In instance A the number of unallocated warnings mostly increases due to a tight resource capacity. As anticipated the cost improvement increases with  $\alpha$  because of the larger range in the constraint of  $u$ . The improvement of the expected costs for the unallocated warnings decreases for larger  $\alpha$  but still for  $\alpha = 0.2$  the MC-RO method leads to better results in  $u$  than the heuristic. Within the heuristic more and more warnings are unallocated in each plan during the three years. When solving the instance with the MC-RO method the increase is smaller and for  $\alpha = 0$  the unallocated warning rate remains almost constant. Thus in instance A within all values of  $\alpha$  an improvement in all objective can be seen. The best value for  $\alpha$  is 0.05 because of the high improvement in  $c$  and  $u$ .

Instance B shows always a low number of unallocated warnings because of the moderate utilisation of the resources. For  $\alpha = 0$  the costs improvement is very small, but this is the only value for which the expected costs for the unallocated warnings are improved. For larger  $\alpha$ , the decline of  $u$  looks dramatically but is acceptable by considering the absolute values. This is illustrated in the third picture, where the unallocated warning rate is plotted over time. Within the heuristic solution and for low values of  $\alpha$ , the rate is very small. And the rates are still low for  $\alpha \geq 0.1$ , when compared to instance A. Therewith the best results are obtained for  $\alpha = 0.15$  because the cost improvement is highest. But by means of  $\alpha = 0.05$  good solutions are

obtained, too. The cost improvement is indeed smaller, but the development of unallocated warnings looks better.

In instance c the number of unallocated warnings stays at a certain level during the three years. But for small  $\alpha \leq 0.05$  the rate even tends to zero and is clearly better than with the heuristic. The costs improvements are similar to instance A with a preferable value of  $\alpha = 0.05$ , the improvement is high in the incurred costs and the costs for unallocated warnings.

## 5 Conclusion

Our first results show that it is possible to find suitable parameters for our evaluation function to generate good results. But in practice the expertise of the railway operator can be used to find the best alternative from a small set of Pareto optimal alternatives calculated and evaluated by the MC-RO method.

Our next step will be the estimation of suitable values for the number of alternatives, scenarios, and the depth. Furthermore, due to the longer calculation time that is usable in practice we even can increase the diversity of the alternatives and therewith the number of compared solutions. For this purpose we have to expand our alternative generator. Some more accurate heuristics will be also developed.

## References

- [1] Budai G., Huisman D. & Dekker R.: Scheduling Preventive Railway Maintenance Activities, *Journal of the Operational Research Society*, 57, 1035-1044, 2006.
- [2] Van Zante-de Fokkert J., den Hertog D., van den Berg F. & Verhoeven J.: The Netherlands Schedules Track Maintenance to Improve Track Workers' Safety, *Interfaces*, 37, 133-142, 2007
- [3] Martello S. & Toth P.: *Knapsack Problems: Algorithms and Computer Implementations*. John Wiley & Sons, 1999.
- [4] Bertsekas, D. & Castanon, D. A.: Rollout Algorithms for Stochastic Scheduling Problems, *Journal of Heuristics*, 5, 89-108, 1999.
- [5] Chaslot, G.; Bakkes, S.; Szita, I. & Spronck, P.: Monte-Carlo Tree Search: A New Framework for Game AI, *Proceedings of the Fourth Artificial Intelligence and Interactive Digital Entertainment Conference*, 216-217, 2008
- [6] Domschke W. & Drexl A.: *Einführung in Operations Research*, Second edition, Springer-Lehrbuch, 1991.



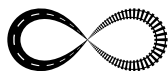

## SMART MAINTENANCE AND ANALYSIS OF RAILWAY TRANSPORT INFRASTRUCTURE (SMART RAIL)

Kenneth Gavin<sup>1</sup>, Irina Stipanović Oslaković<sup>2</sup>, Marko Vajdić<sup>3</sup>, Goran Puž<sup>3</sup>, Velimir Sporčić<sup>4</sup>

<sup>1</sup> University College Dublin, uCD School of Civil, Structural and Environmental Eng., Ireland,

<sup>2</sup> University of Twente, Construction Management and Engineering, The Netherlands,

<sup>3</sup> Institut IGH d.d., Croatia,

<sup>4</sup> HŽ Infrastruktura, d.o.o., Razvoj i građenje, Croatia

### Abstract

Europe needs a safe and cost effective transport network to encourage movement of goods and people within the EU and towards major markets in the East. This is central to European transport, economic and environmental policy. Many parts of Europe's rail network were constructed in the mid–19th century, long before the advent of modern construction standards. Historic levels of low investment, poor maintenance strategies and the deleterious effects of climate change (for example scour of bridge foundations due to flooding and rainfall induced landslides) has resulted in critical elements of the rail network such as bridges, tunnels and earthworks being at significant risk of failure. The consequence of failures of major infrastructure elements is severe and can include loss of life, significant replacement costs (typically measured in millions of Euro's) and line closures which can often last for months. The SMART Rail project brings together experts in the areas of highway and railway infrastructure research, SME's and railway authorities who are responsible for the safety of national infrastructure. The goal of the project is to reduce replacement costs, delay and provide environmentally friendly maintenance solutions for ageing infrastructure networks. This will be achieved through the development of state of the art methods to analyze and monitor the existing infrastructure and make realistic scientific assessments of safety. These engineering assessments of current state will be used to design remediation strategies to prolong the life of existing infrastructure in a cost–effective manner with minimal environmental impact. This paper presents the organization, scope of work and project objectives of the SMART Rail project.

*Keywords: FP7 project, SMART Rail project, degradation of the railway track, new rehabilitation methods*

### 1 Introduction

Safe and efficient transport infrastructure is a fundamental requirement to facilitate and encourage the movement of goods and people throughout the European Union. There is approximately 215,400 km of rail lines in the EU which represent a significant asset [1]. Many of the rail networks in Eastern Europe and in parts of Western Europe were developed more than 150 years ago. These networks were not built to conform to modern standards and suffer from low levels of investment and in some cases poor maintenance strategies. Replacement costs for civil engineering infrastructure items such as rail track, bridges and tunnels are prohibitive. In the current economic climate it is vital that we maintain and develop our transport network and optimize the use of all resources. [2, 3] It is essential therefore those methods used to

analyse and monitor the existing infrastructure result in realistic scientific assessments of safety which allow the effective programming of remedial works. Thus SMART Rail project brings together experts in the fields of rail and road transport infrastructure, with the aim to develop state of the art inspection; monitoring and assessment techniques which will allow rail operators manage ageing infrastructure networks in a cost-effective and environmentally friendly manner.

## 2 Existing problems

Several European countries have highly advanced rail networks where the primary areas of concern in relation to infrastructure performance are related to achieving ever higher network speeds. In new member states such as Slovenia, accession states including Croatia and even in some Western European countries with relatively well developed economies, historic lack of investment in rail infrastructure had led to the situation that some elements of the network are in very poor condition. In these countries, parts of the rail infrastructure would be deemed to have reached the end of its service life when analysed using conventional assessment methods. When incidents occur such as structural failures or derailments, it is common practice in certain regions to simply close the line. Because of the lack of viable alternative modes of transport, such drastic action cannot be adopted in most countries.



**Figure 1** Left: Collapse of Malahide Viaduct on the Belfast–Dublin rail line (August 20th 2009); right: Rainfall induced slope failure at Merano, Italy (April 2010)

Climate change effects are increasing the burden on ageing transport networks with the incidence of infrastructure failure increasing. [4, 5] The construction of the trans-European transport network (TEN-T), which aims to provide interconnection and interoperability of national transport networks within the EU, is seen as vital for the economic competitiveness of the Union and is central to the objectives of achieving balanced and sustainable development. [6, 7] The Cork–Dublin–Belfast rail line in Ireland is one of the 30 TEN-T projects. The Irish railways were amongst the first constructed in Europe, and the 180 m span Malahide viaduct which carries the Dublin–Belfast line just North of Dublin is one of the oldest railway viaducts in the world. In early August 2009 unusual currents developing around one of the piers of the viaduct were reported. A visual inspection was performed on August 18th and no unusual distress to the structure was noted. Three days later the pier collapsed as a local passenger train crossed the viaduct and the Belfast–Dublin express service approached, Fig. 1 (left). The collapse, which was caused by scour of the foundations and was not visible to the inspector, caused the line to be closed for seven months and a repair costs around of €4 million. The scour problem which caused the failure was accelerated by high flows in the estuary caused by recent flooding. [8]

On the 12th of April 2010 a landslide initiated by heavy rainfall, caused the derailment of a train at Merano, in Italy (Figure 1 (right)).

On 31st March 2009, scour caused the failure of a pier on a railway bridge crossing the river Sava in Zagreb during a flood event (Figure 2).



**Figure 2** Failure of railway bridge pier in Zagreb, Croatia (31st March 2009)

Climate change effects are having demonstrable effects on ageing infrastructure. These effects create serious safety issues for the European rail network and pose a significant threat that recent improvements in safety could be reversed. Furthermore, significant economic costs could accumulate in the near future unless action is taken to minimise these risks.

### 3 SMART Rail concept and consortium

In September 2011 SMART Rail project has been launched, funded under theme SST.2011.5.2-6. TPT Cost-effective improvement of rail transport, as a collaborative FP 7 research project. The SMART Rail project brings together experts in the areas of highway and railway infrastructure research, SME's and railway authorities who are responsible for the safety of national infrastructure. Consortium as a whole is given in Table 1.

**Table 1** SMART Rail consortium

No	Name	Short name	Country
1	National University of Ireland, Dublin – University College Dublin	NUID–UCD	Ireland
2	Slovenske železnice, d.o.o.	SŽ	Slovenia
3	Forum of European National Highway Research Laboratories	FEHRL	Belgium
4	EURNEX e.V.	EURNEX	Germany
5	Institut IGH d.d.	IGH	Croatia
6	Zavod za gradbeništvo Slovenije	ZAG	Slovenia
7	Roughan O'Donovan Innovative Solutions	RODIS	Ireland
8	Adaptronica sp. z.o.o.	Adaptronica	Poland
9	Technische Universität München	TUM	Germany
10	Instytut Kolejnictwa	IK	Poland
11	The University of Nottingham	UNOTT	United Kingdom
12	HŽ INFRASTRUKTURA d.o.o.	HŽ	Croatia
13	Iarnród Éireann – Irish Rail	IR	Ireland
14	De Montfort University	DMU	United Kingdom
15	University of Twente	UT	The Netherlands

The goal of the project is to reduce replacement costs, delay and provide environmentally friendly maintenance solutions for ageing infrastructure networks. This will be achieved through the development of state of the art methods to analyse and monitor the existing infrastructure and make realistic scientific assessments of safety. These engineering assessments of current



state will be used to design remediation strategies to prolong the life of existing infrastructure in a cost-effective manner with minimal environmental impact.

In order to achieve its stated objectives the SMART Rail project is clearly structured in four content-orientated work packages (WP1-4), two work packages for project management, (one for administrative and one for scientific management, termed WP6 and WP7, respectively) and one for dissemination and exploitation (WP5), as presented in Figure 3. WP's 1-4 address the core issues of measuring the current state of infrastructure (WP1), quantifying its safety (WP2), implementing remediation strategies where required (WP3) and assessing the economic and environmental costs (WP4). The management work packages WP6 and WP7 are led by NUID-UCD (the project coordinator) which has extensive experience of leading framework projects. Central to the implementation of the project will be the SMART Rail advisory board which will have representatives from national rail operators in Slovenia, Croatia, Hungary, Poland and Ireland. The Dissemination work package is led by EURNEX, the European Rail Research Network of Excellence, which comprises 42 scientific institutes in the area of transport, provides an ideal platform for dissemination of the intellectual property generated through the SMART Rail project.

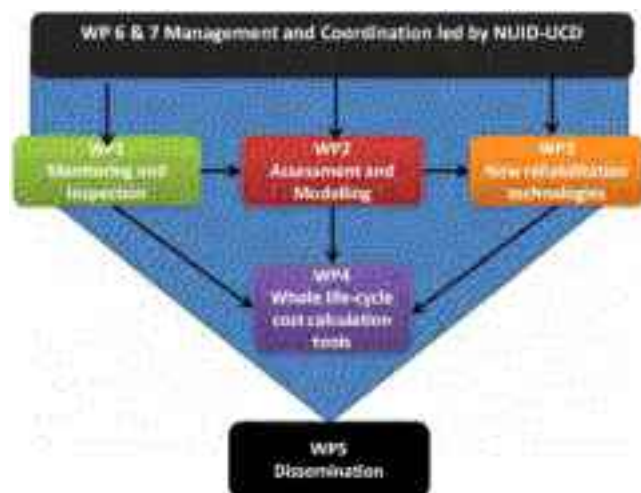

Figure 3 Structure of the SMART Rail project

## 4 Research topics covered in the project

### 4.1 Inspection and monitoring

In recent years concentrated research efforts have led to advances in embedded sensor technology and the use of non-destructive test methods including geophysical techniques such as seismic refraction, Ground Penetrating Radar (GPR) and Multiple Analysis of Shear Wave (MASW) are now commonly adopted in practice. The Smart Rail project proposes to

- Use modern ICT networks to collect data from embedded sensor networks and use it to populate statistical data for structural health monitoring models;
- Consider methods to improve the performance of in-situ techniques (specifically the rate of data acquisition);
- Investigate new application of existing techniques and technology – GPR techniques are now routinely used to profile ballast depths [9] and locate services;

- Apply MASW method for establishment of relationships between shear wave velocity, suction and soil strength;
- Develop a bridge weigh-in-motion system for railway bridges which will be capable of separating the dynamic responses of the structure from the train vibration and will thus be able to detect damage in the bridge. [10]

## 4.2 Assessment

Structural Reliability is an emerging technique for quantifying the safety of structures. In the Smart Rail project a reliability framework will be developed for railway infrastructure. It will encompass not just rail structures (bridges) but all aspects of rail infrastructure such as track susceptible to settlement (derailment risk) and the stability of slopes that might result in landslides onto track. There will be direct links with existing approaches so that probabilistic concepts can be incorporated without the need for a complete overhaul of existing techniques. The main benefit of this type of approach lies in its ability to provide not just a 'snapshot' of the safety of an infrastructural element/network but also to determine how this safety varies as a function of time due to (i) variation in loading, i.e. faster and/or heavier trains (ii) changes in the resistance of a structure due to deterioration or an embankment due to settlement etc. and (iii) the impact of management decisions regarding times of maintenance intervention and the extent of that intervention, both with respect to cost and impact on rail users.



Figure 4 Smart Rail Dynamic Train-Track interaction model will be developed

Improved prediction of differential settlement of the ballast material used in traditional track construction and embedding this in a dynamic train-track interaction model (Figure 4) is at the core of the proposed research. Differential settlement will dynamically excite train suspension systems and this will mean a non-uniform distribution of load along the track. In the first case, it will also mean that some parts of the track are more prone to settlement than others.

## 4.3 Rehabilitation technologies and construction methods

The SMART Rail project focuses on the 'heavy' civil engineering infrastructure (such as bridges, tunnels, rail track and slopes) associated with ageing rail networks. Each element represents a very high cost item (usually quantified in millions of Euro) and unplanned replacement of any single element would cause unacceptable delays for the network (generally measured in months).

Contributions to advancing the state of the art will be concentrated in the areas of open-track, bridges and tunnels.

### 4.3.1 Open track

Optimal global track stiffness will be defined to replace the traditional methods whereby sleepers are isolated to measure stiffness or ballast stiffness is measured in-situ or in the laboratory.

In most railway networks in Eastern European countries train speeds in the past have not exceeded 160 km/h, and dynamic loading was generally not accounted for the track stiffness calculation. In-situ measurements from tracks under live train loads where differential settlement has occurred will be collected and dynamic amplifications will be accounted for, as needed.

Drainage systems are critical to the optimal performance of a railway system. The influence of long-term saturation and contamination of ballast layers with mud and small aggregate (known as mucky spots) has a significant effect on ballast/track stiffness, and requires significant remedial works. Methods to prevent the development of this contamination and in general controlling water ingress will be investigated.

### 4.3.2 Bridges

Consideration of bridge structures will concentrate on methods to:

- Classify structures and define acceptable deflection limits which will depend on the train speed, bridge span and type of the superstructure
- Increase the load bearing capacity of existing railway bridges by the implementation of advanced solutions for the superstructure (composite structure, ballastless track systems, Ultra High Performance Fibre Reinforced Concrete, etc.).
- Evaluation of the distribution of horizontal forces into the superstructure and joints and determination of limit values for longitudinal stiffness.
- 

### 4.3.3 Tunnels

Many existing tunnels have insufficient clearance to allow for electrification. Ballastless track systems offer the opportunity to increase clearance within existing structures. The most effective construction techniques will be determined.

## 4.4 Cost and Environmental Assessment of railway innovation concepts

Advances in the area of whole life cycle analysis will focus on seven key areas:

- 1 Whole-life costing
- 2 Whole life cycle environmental analyses
- 3 Combined cost and environmental assessment
- 4 Assessment of renovation of the old railway structure
- 5 Holistic approach
- 6 Results and experiences
- 7 Multi-criteria assessment

A Multi-criteria railway revitalization decision tool will be developed as a result of this work. The user friendly tool will enable multi-objective optimization of new concepts for renovation of railway structures by the railway industry. It will allow re-developers to conduct their own analyses and to assess the relative importance of options.

## 5 Work progress

The SMART Rail concept is to provide a whole life cycle tool which will allow infrastructure operators to optimise the existing, ageing European rail infrastructure and ensure it remains operable into the future. In order to achieve the SMART Rail concept, project has started with the survey on typical problems on existing railways with the focus on older railway infrastructures. Demonstration sites have been selected or are under negotiation process in Croatia, Slovenia and Ireland. In parallel analysis of existing sensor networks and Structural Health Monitoring (SHM) procedures are conducted. Sensors will be embedded in key elements of rail infrastructure demonstration sites. These will collect real-time in-situ measurements of key parameters which will be transmitted via an advanced IT network to provide critical input data. After assessments of current safety have been undertaken environmentally friendly forms of remediation will be undertaken and the effect in terms of SHM will be quantified. Life Cycle Analysis models that will take input from the SHM and identify the most efficient maintenance programmes for each infrastructure operator, considering financial costs and environmental assessment. Those quantifications will be key performance indicators for the SMART Rail project, as the project outcomes in order to achieve primary aims of the project: a reduction of failures of infrastructure elements, such as tunnels, embankments and bridges.

## Acknowledgment

This research is performed within scientific project 'Smart Maintenance and Analysis of Railway Transport Infrastructure – SMART Rail' (285683), funded by the European Community under the 7<sup>th</sup> Framework Programme. Authors would like to thank all the partners in the consortium for their contribution.

## References

- [1] RailNetEurope, <http://www.rne.eu/>
- [2] A sustainable future for transport: towards an integrated, technology-led and user-friendly system EU 2009 ([www.tracea-programme.eu](http://www.tracea-programme.eu))
- [3] Regulation (EU) No 913/2010 of the European Parliament and of the Council of 22 September 2010 concerning a European rail network for competitive freight Text with EEA relevance, <http://eur-lex.europa.eu/>
- [4] Leviäkangas, P. et al. Extreme weather impacts on transport systems, EWENT project, Deliverable D1, April 2011, <http://www.vtt.fi/publications/index.jsp>
- [5] Evans, A.W. (2010) Fatal train accidents on Europe's railways; 1980-2009, Working Paper, Centre for Transport Studies, Imperial College London.
- [6] Commission Decision of 26 October 2006 establishing the Trans-European Transport Network Executive Agency pursuant to Council Regulation (EC) No 58/2003
- [7] Community guidelines for the development of the trans-European transport network, [http://europa.eu/legislation\\_summaries/other/l24094\\_en.htm](http://europa.eu/legislation_summaries/other/l24094_en.htm)
- [8] RAIU, Investigation Report R2010 – 004 Malahide Viaduct Collapse on the Dublin to Belfast Line, on the 21st August 2009, 2010, [http://www.raiu.ie/download/pdf/accident\\_malahide.pdf](http://www.raiu.ie/download/pdf/accident_malahide.pdf)
- [9] Donohue, S. Gavin, K and Tooliyan, A. (2010) Use of geophysical techniques to examine slope failures, Journal of Near Surface Geophysics. (In Press)
- [10] Smart Maintenance and Analysis of Transport Infrastructure, Collaborative project (SMART RAIL), Description of work, FP 7 project number: 285683, Dublin, 2011.



## 8 STRUCTURES AND STRUCTURAL MONITORING



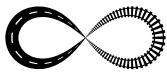

## EXTENDING LIFE OF CONCRETE BRIDGE DECKS THROUGH EARLY DETERIORATION DETECTION BY NDE METHODS

Nenad Gucunski<sup>1</sup>, Ali Maher<sup>1</sup>, Hamid Ghasemi<sup>2</sup>

<sup>1</sup> Rutgers University, U.S.A.

<sup>2</sup> Federal Highway Administration, U.S.A.

### Abstract

Corrosion induced bridge deck delamination is a common problem in reinforced concrete decks. This is especially pronounced in the U.S.A. where far the highest percentage of concrete decks are bare decks. The prevailing inspection practice of bridge decks relies on visual inspection and the use of simple nondestructive evaluation (NDE) tools, like chain drag and hammer sounding. The presented study concentrates on a complementary use of five NDE techniques for the detection of three deterioration/defect types: corrosion, delamination and concrete degradation. The NDE technologies used include: impact echo (IE), ground penetrating radar (GPR), half-cell potential (HCP), ultrasonic surface waves (USW) and electrical resistivity (ER). Each of the five techniques can contribute to a more comprehensive assessment of the condition of a deck. HCP provides information about the likelihood of active corrosion, while ER will assess the potential for corrosive environment. IE can accurately detect and characterize delaminations in the deck, while GPR can identify deteriorated bridge deck areas, in some cases matching the position of delaminations. Finally, the USW provides information about the material degradation through a measurement of concrete elastic modulus. One of the NDE features is that the results are quantitative. This allows objective assessment of the condition of a deck and, thus, objective comparison of bridges on the network level. In addition, NDE allows detection of problems at far earlier stages of deterioration than the traditional approaches. A brief overview of the techniques and their complementary use, illustrated by the results from deck testing on several bridges, is presented. Results include delamination maps from IE, attenuation maps from GPR, modulus distribution maps from USW, HCP potential maps, and resistivity maps from ER.

*Keywords: concrete decks, nondestructive evaluation, GPR, impact echo, electrical resistivity, half-cell potential, surface wave testing*

### 1 Introduction

The dominant practice by state Departments of Transportation (DOTs) in the U.S.A. in evaluation of bridge decks is by visual inspection and the use of simple methods like chain drag and hammer sounding. Such an evaluation is somewhat subjective and can provide information about the deterioration when it is already in its fully developed stage. The presented study concentrates on a more objective condition assessment of bridge decks using a complementary use of nondestructive evaluation (NDE) techniques. The condition assessment has three main components: assessment of corrosive environment and corrosion processes, concrete degradation assessment, and assessment with respect to deck delamination. In all cases deterioration can be detected and quantified at all stages of progression, thus allowing more objective implementation of maintenance or rehabilitation strategies.



The following sections provide an overview of typical bridge deck deterioration and NDE methods used in their detection. The NDE of bridge decks and condition rating is illustrated by the examples from bridge deck evaluation within the Federal Highway Administration's (FHWA's) Long Term Bridge Performance (LTBP) Program. The NDE technologies used in the assessment include: half-cell potential (HCP), electrical resistivity (ER), ultrasonic surface waves (USW) ground penetrating radar (GPR), and impact echo (IE) method. In addition, because the data obtained from NDE surveys are quantitative, a more objective condition rating of bridge decks can be made. The rating can serve multiple purposes: it allows accurate monitoring of deterioration progression with time, and thus its better prediction, it allows more objective comparison of bridges on the network level, and it allows better identification of more deteriorated sections of a bridge through segmentation. Different condition rating schemes, guided by different objectives of their usage are illustrated.

## 2 Concrete deck deterioration and its detection

### 2.1 Concrete deck deterioration

There are many causes of concrete deck deterioration that can be of chemical (e.g. alkali-silica reaction, carbonation), physical (creep, fatigue, overloading, shrinkage, etc.) and even biological nature. However, the prevailing cause of deterioration in concrete bridge decks is a result of rebar corrosion. The rebar corrosion will cause concrete cracking and ultimately lead to bridge deck delamination and spalling. This is illustrated in Figure 1.



Figure 1 Rebar corrosion, delamination and concrete degradation.

Understanding the causes of deterioration, and anticipated defects as a result of deterioration, is essential in identifying the best techniques for their detection and characterization.

### 2.2 NDE methods for concrete deck deterioration detection

The following sections describe technologies used in assessment of corrosion, concrete quality and deterioration, and delamination. There are a number of ways corrosion in concrete decks is assessed. These include evaluation of corrosion activity, measurement of corrosion rate, description of concrete as a corrosive environment, etc. Half-cell potential and electrical resistivity are two most commonly used NDE methods in corrosion assessment of a reinforced concrete elements. The HCP measurement is a simple way to assess the probability of steel corrosion, while ER measurement of concrete describes the corrosive environment and thus potential for corrosion of reinforcing steel. HCP involves the measurement of the electrical potential between the reinforcement and a reference electrode (usually copper electrode in a copper sulfate solution) coupled to the concrete surface (Figure 1 left). A more negative potential indicates a higher probability of corrosion. The measured potential is somewhat

influenced by the concrete cover and the concrete resistance, which varies with moisture content, temperature and ion concentrations [1].



**Figure 2** HCP testing and reference electrode (left), ER measurement and Wenner probe (middle), and USW measurement and PSPA (right).

The electrical resistivity of concrete is highly influenced by presence of moisture and chlorides. The lower the resistivity the higher the corrosion current passing between the anodic and cathodic areas of the reinforcing steel will be. It has been observed that a resistivity of less than  $5 \text{ kohm}\cdot\text{cm}$  will support very rapid rebar corrosion, while a resistivity higher than  $30 \text{ kohm}\cdot\text{cm}$  will not promote corrosion. In many cases the electrical resistivity can be related to the rebar corrosion rate [2]. The most commonly used probe for resistivity measurement is the Wenner probe (Figure 2 middle). It uses four equally spaced probes (electrodes). A current is applied between the outer electrodes and the potential measured across the two inner ones to obtain concrete resistivity.

Ultrasonic surface wave (usw) method enables quantitative assessment of concrete through the measurement of concrete elastic modulus. The modulus is obtained from the measured surface wave velocity for wavelengths shorter than the deck thickness, and assumed or measured concrete density and Poisson's ratio. In concrete decks, the velocity is fairly constant for that range of wavelengths [3]. Variation in the phase velocity is an indication of the variation of concrete modulus with depth, or delamination when there is a significant drop in the measured modulus. One of the devices that can be used for usw testing is portable seismic property analyzer (PSPA) (Figure 2 right).



**Figure 3** Delamination detection using IE (left) and GPR survey (right).

Ground penetrating radar (GPR) provides a qualitative assessment based on the measurement of signal attenuation on the top rebar level. Electrical conductivity and dielectric properties play the primary role in how a GPR signal travels, disperses or reflects within construction materials. Both are significantly influenced by the presence of moisture, chlorides, salts, etc., especially if concrete is cracked and delaminated. The amplitude of the reflection will be highest when the deck is in a good condition and weak when corrosion and cracking are present. Amplitudes for all points are normalized with respect to the best possible condition and corrected for variations due to the rebar depth to obtain the attenuation plot. A unique deterioration threshold for each deck is established using ground truth, such as cores or other NDE methods [4]. In many cases good correlations were observed between the delaminations detected by impact echo, and the zones of high attenuation in the GPR maps. Bridge decks have been evaluated using a variety of GPR systems [5]. However, ground coupled antennas provide more detailed imaging and analysis of the deck condition (Figure 3 right).

### 3 NDE survey results

NDE surveys on bridge decks within the LTBP Program are done on a 60 by 60 cm grid, as shown in Figure 4. The results are typically presented in terms of condition maps and calculated condition rating for a particular deterioration type and the overall bridge deck condition. The following sections provide illustrations of the condition mapping and rating, and their application in condition monitoring.



Figure 4 NDE survey of a bridge in Virginia.

#### 3.1 NDE condition maps

Condition assessment maps of a California bridge evaluated as a part of the LTBP Program are shown in Figure 5. The maps were obtained (top to bottom) from the five described technologies: HCP, ER, USW, IE and GPR. In general, warm colors (yellow and red) indicate deterioration or defect, while cold colors (green and blue) indicate fair or good condition. It can be observed that HCP and ER point to low to no corrosion activity and weak corrosive environment, respectively. The two maps confirm the expected relationship between the two: a corrosive environment is the primary requirement for active corrosion. This result was somewhat expected because of very dry climatic conditions in the bridge area. However, some deterioration still can be observed in IE and GPR maps. The deterioration was likely a result of other causes, like fatigue or overloading.

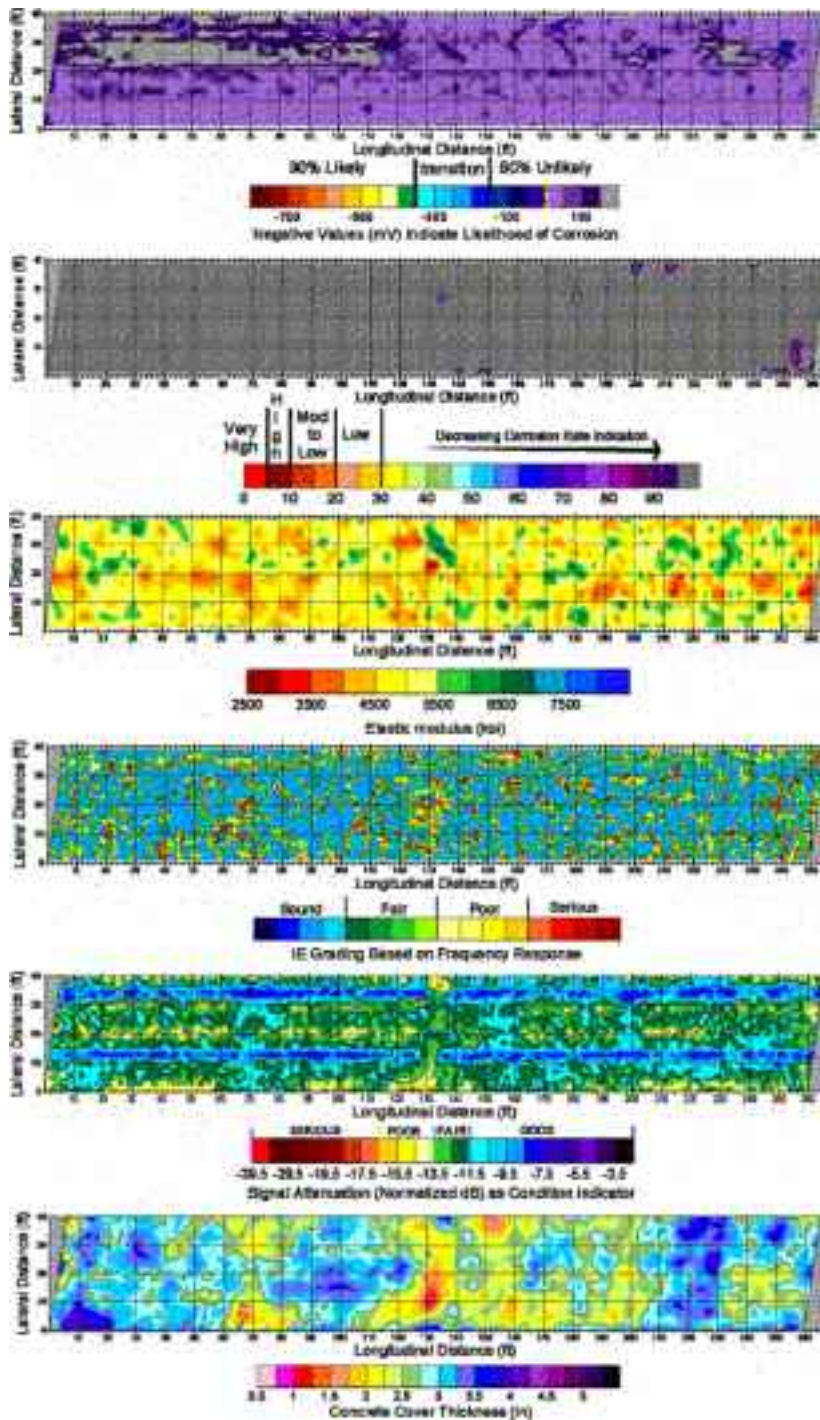

Figure 5 Condition maps from NDE surveys: HCP, ER, USW IE, GPR attenuation map and concrete cover (top to bottom).

Areas of very low concrete modulus obtained from the usw testing are, in general, at locations of delamination identified by impact echo. Finally, the secondary product of GPR testing, the concrete cover map is shown at the bottom of Figure 5. In many cases the detected corrosion induced deterioration can be attributed to low concrete cover.

### 3.2 Deterioration progression monitoring and condition rating

The condition maps from ER survey in 2009 and 2011 for the Virginia bridge shown in Figure 4 are shown in Figure 9. Quiet clearly, a progression of deterioration can be observed during the two year period. Similar results were obtained, but not shown herein, for the other technologies.

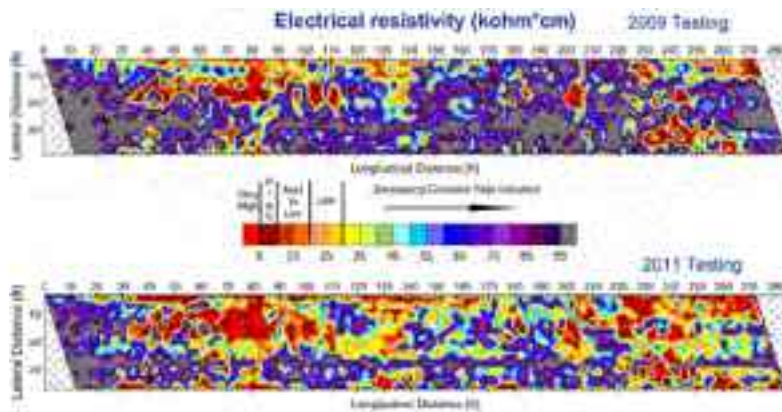

Figure 6 Electrical resistivity maps from 2009 and 2011 for the Virginia bridge.

Because of the quantitative nature of NDE results, a more objective assessment of bridge decks can be made by determining a bridge deck condition rating. The condition rating with respect to each deterioration or defect type is calculated using a weighted area approach. For example, the overall rating on a scale 0 to 100 (best), with respect to delamination is calculated from the percentages of areas falling into three states. The area described as sound is assigned a weight factor 100, the area in the state of progressed delamination (serious condition) a factor 0, and the area of the incipient delamination (fair to poor grade) is assigned a weight factor 50. Different weight factors could be applied to better reflect the experience and judgment of a bridge owner. The overall condition rating of a deck can be defined from a weighted average of condition ratings obtained from different NDE surveys and visual inspection. This is illustrated in Table 1 for the same Virginia bridge using the HCP results for corrosion activity rating, IE results for delamination rating, and GPR results for concrete degradation rating. The overall rating was calculated as a simple average of the three. The table also summarizes the changes in rating that occurred during a two-year period for different sections of the bridge deck.

Table 1 Deck condition rating for Virginia bridge for 2009 and 2011.

	2009	2011
Active Corrosion	39.4	28.1
Delamination Assessment	70.0	57.2
Concrete Degradation	48.1	26.3
Combined Rating	52.5	40.2

## 4 Conclusions

NDE technologies enable detection and characterization of deterioration processes at all stages of development. Complementary use of NDE technologies leads to a more comprehensive condition assessment and in many cases may assist in identification of underlying causes of deterioration. Because of the quantitative nature of the NDE results, more objective assessment of the deck condition can be obtained by determining the condition rating. The rating based approach enables more objective rehabilitation prioritization on the network level.

## References

- [1] Elsner, B.: Half-Cell Potential Measurements - Potential Mapping on Reinforced Concrete Structures. *Materials and Structures*, 36(7), pp. 461-471, 2003.
- [2] Whiting, D. A. & Nagi, M.A. (eds.): *Electrical Resistivity of Concrete – A Literature Review*, PCA R&D Serial No. 2457, PCA, Skokie, IL, 2003.
- [3] Gucunski, N., Romero, F., Shokouhi, P. & Makresias, J.. *Complementary Impact Echo and GPR Evaluation of Bridge Decks on I-84 in Connecticut*. GSP 133, ASCE, 2005.
- [4] Nazarian, S., Baker, M.R. & Crain, K.: *Development and Testing of a Seismic Pavement Analyzer*. Report SHRP-H-375, NRC, Washington, D.C. 1993.
- [5] Romero, F.A., Roberts, G.E. & Roberts, R.L.: *Evaluation of Bridge Deck Survey Results Used for Delineation and Removal/Maintenance Quantity Boundaries on Asphalt-Overlaid Reinforced Concrete Deck*, SMT/NDE Conference, pp. 23-30. 2000.

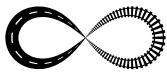

## VIADUCT DESIGNS ON THE SECTION OF THE PAN–EUROPEAN CORRIDOR X IN SOUTH SERBIA

Slavica Vucetic–Abinun

*The Highway Institute, Bridge design department, Serbia*

### Abstract

On the planned section of the motorway E–75, a viaduct design has been developed to connect the deep valley and Koznicka River. The right and the left lane of the motorway divert in the viaduct area, because the motorway leads into two separate tunnel tubes, right after the bridges.

According to the layout solution, a design has been prepared for a 6 field viaduct, bridged over by previously prestressed precast girders with a span  $L = 25.40$  m and which have continuity over intermediate piers. Within the scope of a cross section, four precast girders with 'I' cross-section, with height of  $h = 1.70$  m and mutual spacing  $\lambda = 3.00$  m, have been anticipated. Reinforced concrete pavement slab is cast over the girders. Reinforced concrete cross girders above intermediate piers are being cast together with a slab, thus providing continuity. The impact calculation within the load girders, caused by their own weight, fresh concrete mass of cross girders and the pavement slab, has been carried out within the first phase. For this loading phase calculation and impact control have been carried out within the bearing beams and intermediate piers for cases of symmetrical and asymmetrical load disposition. After the executed continuation of the span structure and formation of a continuous panel structure with intermediate piers, calculations have been carried out for the impact of primary and additional constant load, traffic volume, additional effects and exceptional effects, using the SOFISTIK software package.

*Keywords: viaduct, prestressed girders, continuous structure, static impact*

### 1 General data

On the E–75 motorway, which passes through Serbia from Horgos to Presevo, a 26.4 km long south section that passes through the gorge Grdelica, is the most complicated section design wise and the most expensive section for construction. This gorge represents a natural transport corridor, which connects Aegean Sea and Asia. A preserved Roman and medieval 'Imperial Road' is located there. The old Belgrade–Nis–Solun railroad also passes through there, as well as the modern main road. In this morphologically narrowed gorge profile there are several settlements, networks of electric feeders (of high and low voltage), international coaxial telephone cables, as well as the local water supply system. Under such complex morphological, geologic–geotechnical and other field conditions and restrictions, geometrical elements of the motorway route are adjusted to present conditions, providing various engineering solutions and structures. The left and right motorway carriageways are separated in the area of viaducts, because immediately after the bridges the motorway enters two separated tunnels.



## 2 Data for design documents preparation

- Preliminary design
- According to the Preliminary design, the viaducts are planned to be constructed over the river Koznička reka.
- The adopted solution includes a continuous frame structure as well as a span structure made of prestressed prefabricated girders. Founding of viaducts has been accomplished directly, via footings in an open foundation pit.
- The Employer's Terms of Reference.
- The motorway Final Design in the area of the viaduct,
- A geological – geotechnical survey,
- A hydrological – hydraulic survey of river regulation (the River Koznička reka) with calculation of the bridge span.

## 3 Motorway elements in the viaduct area

Left and right motorway carriageways are separated in the viaduct, because immediately after the bridges the motorway enters two separate tunnels. The finished level of the motorway is in vertical convex curve,  $R_v=50.000\text{m}$ . Cross-falls of the pavement on the both motorway carriageways vary throughout the entire length of bridges. On the left motorway carriageway, the cross-fall is single-sided towards the left pavement edge and amounts:  $i_{\text{pop}}=3.69\% - 4.50\% - 3.51\%$ . On the right motorway carriageway, cross-fall of the pavement is warping, from  $i_{\text{pop}}=2.50\%$  at the beginning of the bridge (towards the right pavement edge) to  $i_{\text{pop}}=1.60\%$  at the end of the bridge (towards the left pavement edge). Both carriageways are in transition curves of various parameters.

The viaduct width is aligned with the width of the motorway pavement and amounts to:

- Pavement width:  $B_k=10.05\text{m}$
- Width of space between inner brackets of viaducts is variable
- Thickness of prefabricated cornice on outer edges of brackets, each:  $d=8\text{cm}$
- Total width of every viaduct on the motorway amounts to:  
 $B = 1.95 \times 2 + 10.05 + 0.08 \times 2 = 14.11\text{ m}$

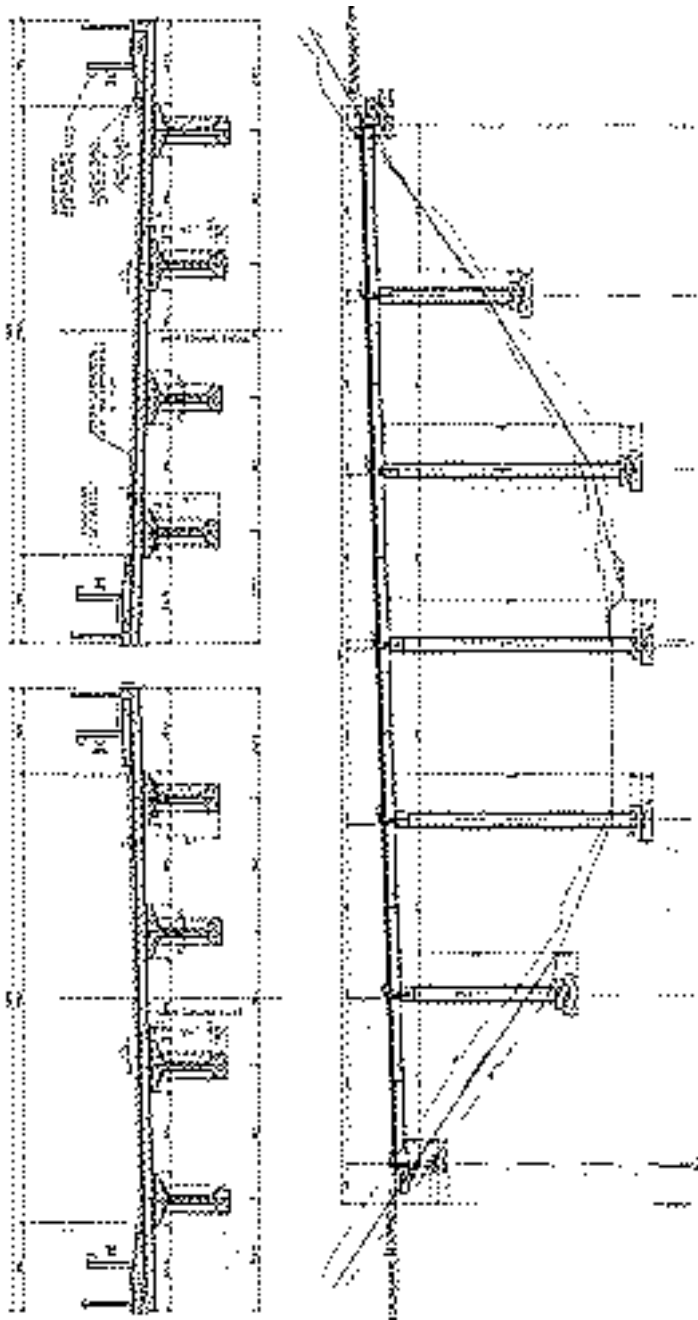

Figure 1 Cross section and longitudinal section of the bridge

## 4 Structural solution for viaducts

### 4.1 Superstructure

Viaducts have been designed according to the dispositional solution, with 6 spans each, bridged by prestressed prefabricated girders, with static span  $L=25.40\text{m}$ , which have continuity above intermediate piers, which results in a semi-integral structure. In cross-section there are four prefabricated girders at a distance of  $\lambda=3.00\text{m}$ . A reinforced concrete pavement slab is cast over girders, with thickness of  $d=22\text{cm}$ . Reinforced concrete cross girders are cast together with a slab above intermediate piers, which makes a continuation, and together with the pier a continuous frame structure is formed.

Within this system, impacts of moving load are received, additional permanent and exceptional impacts.

Prefabricated girders have 'I' cross-section, height  $h=1.70\text{m}$ , width of the upper flange  $b_1=1.20\text{m}$ , lower flange  $b_2=0.60\text{m}$  and ribs  $b_r=0.20\text{m}$ . In the middle of the main girders, cross girders are planned, width  $b=0.30\text{m}$ , which are concreted subsequently. Longitudinal, main and cross girders form a normal crib. Longitudinal crib axis follows a tangent curve on the part of the transition curve on every span. The carriageway curvature on viaducts is achieved with a concrete pavement slab.

Girders are being prestressed by three cables  $12 \text{ } \varnothing 15.2\text{ mm}$ , rated strength  $f_{pk}=1.860\text{ N/mm}^2$ . Starting force, per each cable is  $F_p=0.72 \times F_{pk}=2.250\text{ kN}$ , and the final force in the middle of girder span is:  $F_{\infty}=1.744\text{ kN}$ .

Cross girders above bearings on the abutments C1 and C7 are prestressed with 3 cables  $7 \text{ } \varnothing 15.2\text{ mm}$ , rated strength  $f_{pk}=1.860\text{ N/mm}^2$ .

Starting force, per cable is  $F_p=0.80 \times 1.062\text{ kN}=850\text{ kN}$ , and final force, with 15% of loss, is:  $F_{\infty}=722.2\text{ kN}$ . Tightening of girders secures the impact that will occur during the replacement of bearings in the operational phase of the bridge. During the replacement of bearings the use of hydraulic presses is planned, and those should be placed below the middle area of tail cross girders.

Cross girders in the middle areas of main girders are prestressed with 3 cables  $7 \text{ } \varnothing 15.2\text{ mm}$ . Starting force, per one rope, is  $F_p=0.70 \times 1.062\text{ kN}=743.4\text{ kN}$ , and final force within the rope, with 15% of loss, amounts to  $F_{\infty}=(1-0.15) \times 743.4=632.0\text{ kN}$ .

The connection between the abutments and span structure is achieved via transflex expansion devices with carpeting of reinforced rubber, type  $\tau-100$  with expanding ability  $\Delta L=\pm 50\text{ mm}$ . During concrete works on the pavement slab and tail cross girder, it is necessary to take into account the assembly of expansion devices. Support of span structure on the abutments is accomplished by reinforced elastomer bearings  $NAL \text{ } \varnothing 400, d=76\text{ mm}$ .

### 4.2 Substructure

Each viaduct substructure is made of two abutments and five intermediate piers with foundations. Choosing the position of piers is determined by land contour, finished levels of the motorway carriageways and geotechnical field data in the area of viaducts.

Intermediate bridge piers are made of reinforced concrete with a box, rectangular cross-section, dimensions  $2.40 \times 6.00\text{ m}$ , each having two cells and vertical walls with thickness  $d=30\text{cm}$ . Inside the head of every intermediate pier, there are reinforced concrete pile helmets, monolithically connected to the pier body. Dimensions of the pile helmet are  $b/d=2.40/6.00\text{ m}$  with double-sided brackets with spans of  $2.65\text{m}$ . Total length of the pile helmet is  $11.30\text{m}$ . The height of the pile helmet at fixed end, at the intersection with the pier wall, is  $2.00\text{m}$ , while at the end of the bracket the height is  $1.00\text{m}$ .

Contact area of main girders and pile helmet of intermediate piers varies due to the motorway route curvature and it is provided in the design documents.

Pier heights are determined on the basis of land contour and geotechnical profile of each pier location. In intermediate viaduct piers, the stem height on both motorway carriageways (not including the height of pile helmet) varies from 16.00m to 38.00m.

The design engineer has determined the depth, manner of founding and environment, based on recommendations from the geological – geotechnical survey. Founding of intermediate piers is performed directly on reinforced concrete pads of thickness  $d_1=150\text{cm}$  below which is the oversite non-reinforced concrete, thick  $d_2=180\text{cm}$ .

The solution for abutments is conditioned by distinctive features stemming from their position, land contour and depth on which the solid rock mass is located. All structural elements of the abutments are made of reinforced concrete.

Abutments, C1 – of the right carriageway and C7 – of the left carriageway, are composed of head walls, point-bearing wing walls, counterforts for stiffening of head carcass, pile helmets for bridge span structure support and parapet beam with crossing slabs. The footings are adjusted to the field in cascades.

Thickness of head walls carcass is  $d=60\text{cm}$ , while the thickness of carcass of each, the wing walls and the counterforts, are  $d=40\text{cm}$ .

The abutments structure, C1 – of the left carriageway and C7 – right carriageway of the motorway are different because of the land contour.

Gravel wedges will be positioned behind head walls of the piers. Reinforced concrete crossing slabs  $d=0.20\text{m}$  thick and  $3.00\text{m}$  long, are anticipated for the connection between the viaduct and the motorway road base, above gravel wedges, and they will rely on parapet beams.

Reinforced concrete pile helmet is horizontal and of constant height. In order to achieve necessary design cross fall, bearings are placed on horizontal reinforced concrete ashlar of variable height. Bearing ashlar structure and altitude of cross-girders provide for, if necessary, a simple replacement of bearings or some other intervention during their maintenance. Parapet beams are monolithically connected to pile helmets. The length of beam covers the entire width of the head carcass of the abutment; beam thickness is  $d=0.50\text{m}$ ; height of parapet beam is variable and depends on the pavement cross fall. The beam structure has provided the approach to the area between the parapet beam and the tail cross girder of the viaduct for easier access to bearings and expansion devices during check-ups and possible interventions. The shape of the parapet beam top is adapted to the requirements of proper assembly of expansion devices.

The total length of the viaduct on the right motorway carriageway is  $L=168.06\text{m}$ .

The total length of the viaduct on the left motorway carriageway is  $L=169.50\text{m}$ .

### 4.3 Static analysis of the structure

Viaducts belong to the first category – 'bridges on motorways'. Computational pattern for traffic volume  $v_{600} + v_{300}$  has been used during impact calculation.

Impact calculation has been carried out for two stages of loading. The first stage refers to the assembly of the main girder. Impact calculation in girders for their own weight loading has been carried out with green concrete mass of cross girders and a bridge deck. Calculation and control of impact has been carried out, for this stage of loading, in pile helmets and intermediate piers for symmetrical and asymmetrical loading positions.

The second stage of loading refers to a phase after performed continuation of the span structure and formation of the frame structure, with intermediate piers. Calculation of impacts in continuous frame structure of the viaduct due to basic and additional loading, traffic loading, additional impacts (changes in temperature, wind force and stopping of vehicles) and exceptional effects (earthquake force) has been conducted on a model using the software package SOFISTIK.

The theoretical model for determining impacts on the construction is three-dimensional and based on the finite element method. The bridge structure is modelled by a certain number

of smaller size areas of finite dimensions using bar and plate elements, which represent the finite elements, interconnected in a finite number of knot points. This knot cluster represents the finite element network for the entire bridge. Calculation of impacts on the intermediate piers with pile helmets, as well as on the abutments, was performed on special models of the software package SOFISTIK.

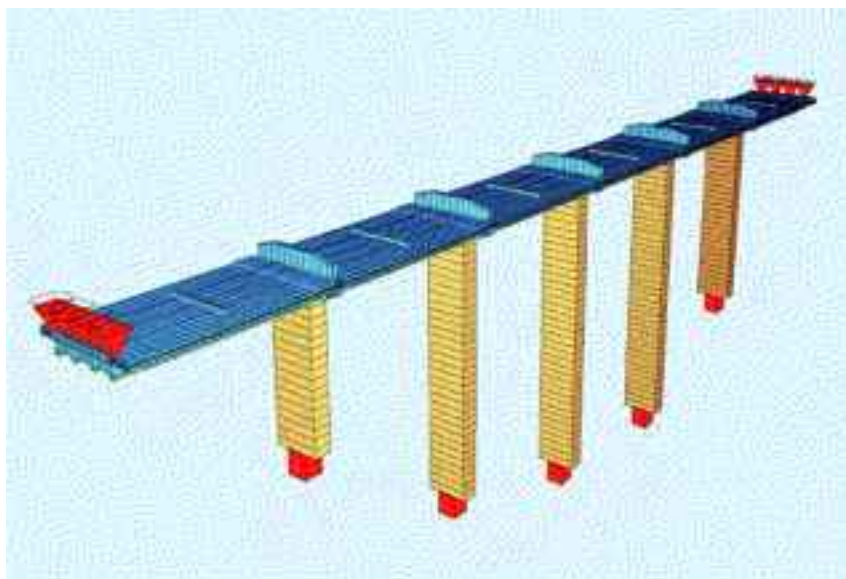

Figure 2 3D model of the bridge, from the software package SOFISTIK

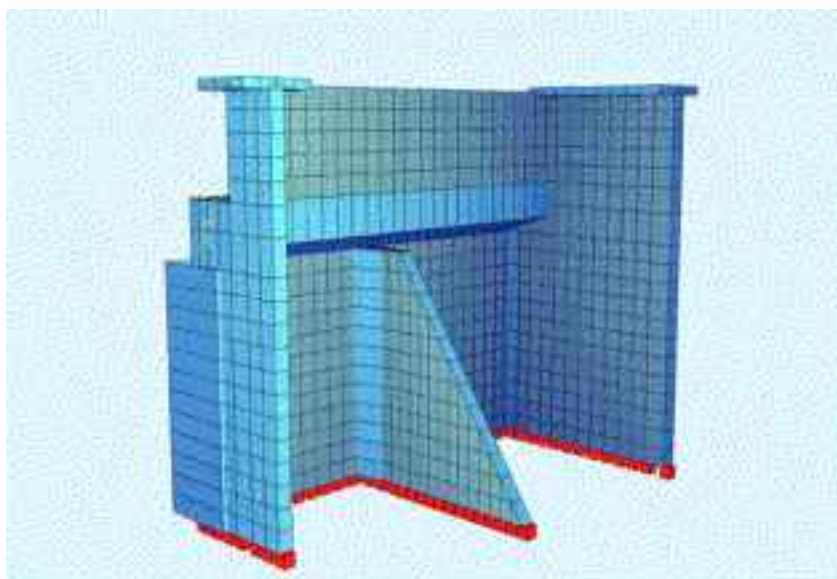

Figure 3 3D model of the bridge abutment

## 5 Building structures

A waterproof system with polymer-bitumen membranes for welding and embedding of polymer-bitumen membranes in a single layer is planned for reinforced concrete overpass bridge deck waterproofing.

Asphalt pavement shall be constructed on the structure in two layers, with total thickness  $d=10\text{cm}$  with a waterproofing layer.

Pavement is lined with stone curbs, with dimensions  $20/13\text{cm}$ , which are elevated by  $7\text{cm}$  from the pavement surface. The position of curbs is defined by the width of the motorway carriageway in the area of viaducts.

In order to secure car traffic, steel guard rails SUPER-RAIL BW H2 – B – W4 (DIN EN 1317-2) shall be installed on viaducts.

Public lighting piers shall be spaced on the inner side of the viaducts (towards the green area).

## 6 Conclusion

The viaducts have been designed as semi-integral structures, without expansions and bearings on intermediate supports, thus eliminating potentially weak spots and reducing costs of construction and maintenance during the operational phase, and making a safer traffic.

Concreting of bridge deck above precast girders provides a joint interaction in the cross-section, as well as the possibility of application at bridges in a curve and neutralizing geometric errors during construction.

The use of modern computer equipment and programmes based on the finite element theory provides a rapid and exact analysis of these bridges, on a physical 3D model.

## References

- [1] The existing design documents, prepared at the Highway Institute.
- [2] Milenko Przulj: Integral concrete bridges, a paper for the 13<sup>th</sup> Congress of the Serbian Structural Engineering Society, Zlatibor, September 2010.



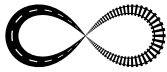

## FINAL DESIGN FOR WIDENING OF BRIDGE OVER NISAVA RIVER, ON THE RIGHT CARRIAGEWAY OF THE MOTORWAY E80: NIŠ–DIMITROVGRAD

Jasmina Damnjanovic, Igor Stefanovic

*The Highway Institute, Bridge design department, Serbia*

### Abstract

On the main M–1.12 road, section Niš–Dimitrovgrad, there is a reinforced concrete bridge over Nisava River. It was designed in 1971 by the Highway Institute, and built afterwards in the period 1972 – 1973. The bridge is a continuous frame construction with three fields, and distribution of spans 10.4 + 20.8 + 10.4 m.

In the course of many years, due to inadequate maintenance, considerable damages occurred on the facility. In the year 2006, the main repair design was prepared, but the work has not been carried out as yet. Because of the preparation of the final design of E–80 motorway, Niš–Dimitrovgrad, it was required to widen both the alignment of the existing main road M–12 and the existing bridge itself. Along with the final design of the Nisava bridge, widening (to the required motorway profile) and necessary repair measures of the structure have been anticipated.

*Keywords: reinforced concrete bridge, repair, widening and motorway.*

### 1 Introduction

The existing reinforced concrete bridge over Nisava River, 'NISAVA III' is located at km. 55+221.20 of the Main M–1.12 road, section: Niš–Dimitrovgrad. The bridge was constructed in the period from 1972 to 1973 and is a continuous frame construction with three fields, and distribution of spans 10.40 + 20.80 + 10.40 m in total length of 51.0 m, Fig. 1.

The cross-section of the bridge is comprised of a cruciform reinforced concrete bridge deck built over a crib made of two longitudinal main beams, on centre-to-centre spacing of 5.0 m, with cross girders at every 5.20 m. There are brackets on each side, with 2.65 m spans from the main beam axis and with 1.45 m wide pedestrian pathways on top.

The left (abutment) pier is a reinforced concrete structure with fixed joint bearings and is founded on rock, over a 2.0 m high block of compacted concrete.

The intermediate (river) pier on the left riverbank, with the  $\varnothing$  100 cm cross-section, is founded directly on the rock, on a pad foundation.

The intermediate (river) pier on the right riverbank, with the  $\varnothing$  100 cm cross-section, is founded on a rock over a reinforced concrete well.

The right (abutment) pier is a 10.0 m high reinforced concrete structure with two rocker bearings – reinforced concrete pendulum. Between the head and wing walls there is a material filling. The abutment has been founded over a reinforced concrete pad foundation in a shape of a Cyrillic letter 'П'.





**Figure 1** Upstream view of the existing bridge

## 2 Condition of the existing bridge

Examination of the bridge has been carried out on 29<sup>th</sup> of March 2006 and it was concluded that during decades of operating, inadequate routine maintenance and untimely repair significant damage to the structure has been made.

Evidence of water penetration has appeared on both abutments, through the expansion device in the area of bearings, as well as confluence down the head and wing walls. Concrete damage has been observed in the area of lower joints in both pendulums, as well as corrosion of pendulum reinforcement. Both of the pendulums deviate from the vertical by about 20 mm. The main beams endings, in the bearings area are, over their entire height, influenced by aggressive water and salt impacts, which penetrate damaged expansion devices, causing severe damage to the concrete layers, while the exposed reinforcement has considerably corroded., Fig. 2.

The pedestrian pathway on the right wing of the S1 abutment was demolished during the formation of an 'illegal' access road to the left bank, for depositing the excavated material during the railway profile widening. Deposited material has partly backfilled the bracket and pedestrian pathways. Not having been designed for vehicle operation, the bracket is exposed to damage. Expansion devices on the pavement and pedestrian pathways are damaged as well, Fig. 3.



**Figure 2** Vertical impairment and deviation of bearings



**Figure 3** Exposed, corroded reinforcement

Basic design anticipates three gullies on the bridge. The first one is without grating; the second has a tub showered with leaves and chippings, while the parts of the third gully are missing. There is only an opening for a gully inside the concrete bracket of the pedestrian pathway which is not located on the designed place, so that the surface pavement water flows over the expansion device before it reaches the opening of gully. In the area of the opening, since

the elements of a gully are missing, the surface pavement water, salt and frost jeopardize the concrete and reinforcement of bridge components and expansion devices.

Pedestrian guard rail on the right wing of the S<sub>1</sub> abutment was demolished during the construction of an 'illegal' road. The guard rail was damaged by corrosion. On certain places, knuckle and post are completely discontinued, due to damages made by corrosion.

Riverbed, as well as the banks is not regulated in the bridge zone. The left bank and the riverbed, upstream from the bridge, are turned into a landfill with a large quantity of stone material excavated during the works on widening the railway profile. Because of material deposition, the first bridge span was virtually covered and the course of the river flow was changed. Water flow has been accelerated by narrowing of the riverbed and it has been directed towards the intermediate pier S<sub>3</sub> and the abutment S<sub>4</sub>, thereby making these piers affected.

After a performed visual inspection, damage and condition assessment rating calculation of the existing bridge has been carried out for the period during which the inspection was performed.

- rating value: 927
- condition assessment: unsatisfactory
- type of maintenance: repair planning

The final design for the bridge repair was prepared the same year, but the repair itself has not been performed. For the preparation of motorway E-80: Niš–Dimitrovgrad final design, in 2010, the widening of the existing main road alignment M-12 and of the existing bridge was necessary, Fig. 4. The bridge over Nisava River final design, on the newly designed right carriageway of the E-80 motorway, anticipates bridge widening in accordance with the required motorway profile, as well as the necessary structure repair.

Chief designer of the original final design for the bridge repair and the final design for widening of bridge over Nisava River is Mr Petar Spasić, chief engineer at the Department for design of bridges and structures, The Highway Institute, Belgrade.

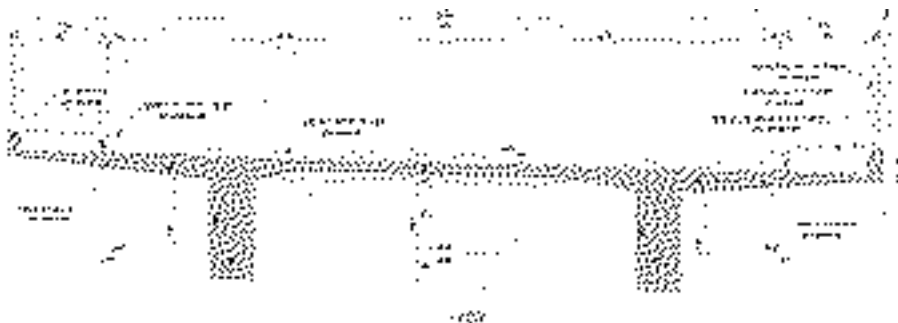

Figure 4 Cross section of the existing bridge

### 3 The newly designed bridge

Dispositional solution has been used for the design of continuous frame structure with three spans and for the existing bridge, with static span 10.40+20.80+10.40 m with indented cross-section. There are three major beams in the cross section at distances of 5.0 m, Fig. 5. On the outer sides, there are brackets with substructure and an inspection path, each 1.95 m wide. The width of the bridge is aligned with the pavement width on the right motorway carriageway and complies with the requirements of the Terms of Reference of the Employer, and amounts to:  $B = 2 \times 1.95 + 10.70 + 2 \times 0.08 = 14.76 \text{ m}$

The formation of the bridge cross section was preceded by preliminary works on removing the elements of traffic profile of the existing bridge, repair works on the bridge frame structure and works on bracing the elements of the existing bridge cross section with the expansion structure. Bracing is achieved through following:

- anchor installation for connecting the old and new bridge deck, and
- boring the holes through ribs of the main beams for a cable line for transversal tightening of cross-girders over intermediate (river) piers and abutments.
- In order to create a cross section of the new bridge, the following works on reinforcing the existing bridge span structure have been envisaged by the design:
  - construction of reinforced concrete 'cover plates' of 0.23 m on the sides and linings of 0.20 m, on the bottom side of main beams,
  - construction of reinforced concrete 'cover plates' of 0.35m on the sides and linings of 0.20 m, on the bottom side of cross girders, above the bearings on the abutments,
  - construction of the reinforced concrete 'cover plates' of 0.20 m on the sides of cross girders above intermediate, river piers.
- works on bracing components – elements of the existing bridge cross section with the expansion structure,
- tightening of the cross girders over intermediate (river) piers and the abutments.



**Figure 5** Cross section of the newly-designed bridge

A reinforced concrete cruciform reinforced deck is cast over beams and has variable thickness of 32–22 cm, as a result of the cross falls alignment of the existing pavement with the newly designed motorway cross section. Secondary cross girders (bo x do = 0.3x1.0 m) are cast along with the bridge deck, on centre-to-centre spacing of 5.16 m.

Substructure of the new, widened bridge is comprised of two abutments, S1 and S4, and two intermediate (river) piers, S2 and S3, along with foundations. Choosing piers position within the expansion frame structure is conditioned by the pier position of the existing bridge. The span structure together with intermediate piers forms a continuous frame structure.

Inside the bridge pier cap there is a reinforced concrete cross girder for frame structure, monolithically connected to the pier stem. The height of the new piers, as well as of the existing ones, is 7.00 m.

Pier spots S2 and S3 refer to two reinforced concrete piers with circular cross section -  $\varnothing$  140 cm, at a distance, in the cross section -  $\lambda = 5.00$  m. The existing intermediate piers have  $\varnothing$  1.00 m and they have been strengthened by reinforced concrete circular lining  $d = 0.20$  m.

In order to establish a connection between reinforced concrete lining used for strengthening the intermediate piers with cross girders and foundations of the existing bridge structure, the design anticipated the following works:

- removal of the reinforced concrete pad segment, on the pier spot S2, for anchoring of lining reinforcement, while preserving the existing pad reinforcement,

- removal of the reinforced concrete pad segment and circular ring of well, up to the pad height on the pier spot S3, for anchoring of lining reinforcement; while preserving the existing pad reinforcement and part of the wall of the well,
- formation of a new reinforced concrete pad with newly designed dimensions, on the pier spot S2,
- restoring the removed parts of the well and pad, on the pier spot S3,
- vertical concrete punching of the existing cross girders above river piers for passage of anchor part of pier reinforcement.

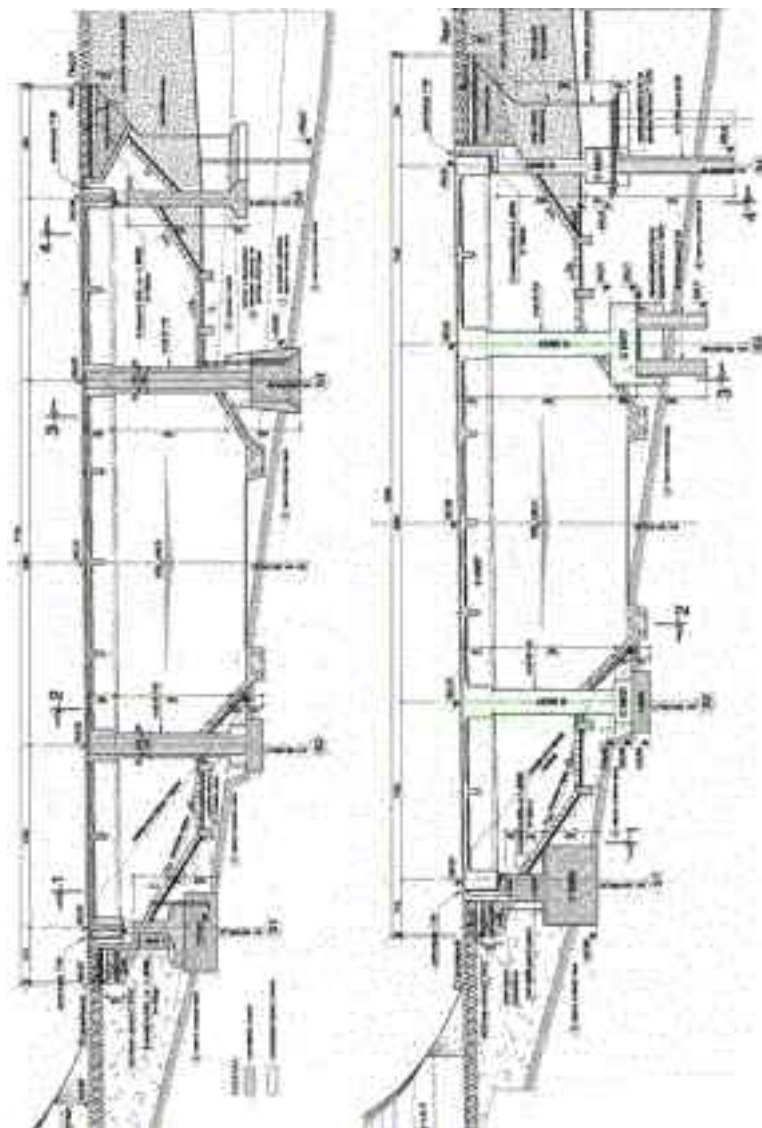

Figure 6 Longitudinal profile of the existing bridge and the newly-designed bridge

The new intermediate (river) pier S<sub>2</sub>, on the left riverbank, has been founded directly on the rock, on the pad foundation. Founding of the new pier, on the pier spot S<sub>3</sub>, shall be carried out on a 'battery' made of four piles. Reinforced concrete piles with large diameter, type HW Ø 90 cm, have been adopted. Connection between the piles 'battery' and stem of the intermediate pier is achieved through reinforced concrete deck, square at the base. Design length of piles on the pier spot is  $L_s = 4.00$  m. Solution for the abutments is conditioned by specific features resulting from the position and the existing piers structure and field configuration, which requires that founding should be performed directly on the rock as well as on the existing pier (pier S<sub>1</sub>), i.e. on reinforced concrete piers with large diameter type HW Ø 90 cm, and length  $L_s = 7.00$  m (pier S<sub>4</sub>). The existing (abutment) pier S<sub>4</sub> has been founded over a strip foundation filled with gravel and sand material. The existing abutments are ridged box reinforced concrete structures. The abutments are formed by head walls, point-bearing wing walls with suspended wings, bearing beams for supporting a span structure of the bridge and parapet beam with transition slabs (pier S<sub>4</sub>).

River regulation is designed for the bridge area, and it would provide banks protection with stone blocks, and thereby would secure the abutment S<sub>1</sub> from potential erosion and removal of unstable riverbank material. In calculating the static impacts, computational pattern of traffic load - v 600 + v 300, as well as SOFISTIK software package was used.

## 4 Conclusion

The purpose of this paper is to show the complexity of works regarding the design, as well as the construction works, because of the simultaneous performance of repairs, strengthening and widening of the existing bridge structure. The implemented technical solutions during the works on strengthening and widening of the span structure and piers of the existing bridge require particular attention during the following:

- construction and assembly of scaffolding and formwork; construction of scaffolding must provide the stability of span structure during the execution of works on removing the parts of supporting elements of the existing bridge,
- inspection, recording and grouting of cracks  $d \geq 0,2$  mm on some parts of the existing bridge span structure,
- installation of anchor fittings for the connection of new, reconstructed concrete reinforcements with reinforced concrete permanent structure of the existing bridge, concrete works on reinforcement of permanent structure of the existing bridge, concrete works on new reinforced concrete permanent structure of the bridge expansion,
- execution of works on cross girders tightening, for bracing the existing and the new bridge span structure.

All works shall be executed in the purpose of obtaining a safe and operational facility with a long service life.

## References

- [1] The existing design documents, prepared at the Highway Institute.



## SPECIFIC FEATURES OF A5 HIGHWAY–BRIDGE OVER RIVER DRAVA

Vladimir Moser, Sanja Dimter, Ivana Barišić

*Faculty of Civil Engineering Osijek, Croatia*

### Abstract

Slavonija and Baranya County, which occupies almost 20% of the total Croatian area have a very auspicious traffic position due to the main European transport routes. Construction of highways in this area that has so far been relatively isolated to other parts of Croatia have many positive effects both locally and globally through economic and social development. Beli Manastir–Osijek–Svilaj highway is a part of the International Pan–European Corridor Vc that connects North Europe with the Adriatic Sea. This part of that corridor is passing through two parts of eastern Croatia very different in macro–relief and climate: east–Croatian lowland and Slavonian Posavina with Požega valley. The specific feature of this section is its transverse position due to which it intersects a number of state, county and local roads, two routes of existing railway lines (one main railway line and one Clas I) and it also intersects two rivers, Sava and Drava with the existing waterway routes. To demonstrate that even within design and building of roads through the lowland part of Croatia there are challenges, details of the bridge across river Drava project and constructions so as the basic Corridor Vc features on its section through Slavonija and Baranya County will be presented in this paper.

*Keywords: A5 highway, bridge, Drava, Corridor Vc*

### 1 Introduction

One of the main prerequisites for the development of each country is developed and modernized motorway network integrated into global transportation system. The great advantage of Croatia is its position in Central European, Mediterranean and Danube region thus it is located at the crossroads of globally significant transport corridors.

Development of motorway in Croatia started in 1950s when building of single–carriageway road (Brotherhood and Unity Motorway), first between Zagreb and Belgrade, and Zagreb and Ljubljana has started. This road was designated as the first phase of motorway construction and, it is interesting that it was built with concrete pavement [1]. Construction of the first kilometers of motorway, as the result of need for connection between the northern continental and southern coastal areas started in the mid–1960s when motorway Zagreb–Karlovac (45 km long) as the first toll collection motorway in the region and the exiting section from Rijeka towards Zagreb (10 km long Orehovica–Grobnik section) were built [1].

Until 1990th the Slavonski Brod section was completed, some of the larger cities bypass (Rijeka, Split, Osijek) were built, tunnel Učka and Krk Bridge were open to traffic so Croatia had 305 km long motorway network.

During the war and postwar period, motorway construction was weaker in intensity, but even within this period of time continuation of studies and designs of future motorway sections were ensured. Since 1991 to 2000, construction of 230 km long motorway sections were completed and Croatian national motorway network was 541 km long [2].

During the next ten years, intensive motorway construction is recorded in Croatia. Within this period of time, over 700 km of newly constructed motorways has been open to traffic, which

means average of 80 km newly constructed motorway per year. Figure 1a shows state of national motorway network in 1999 and figure 1b state on national motorway network in 2011 [2].



**Figure 1** State of Croatian motorway network during 1999. (a) and 2011. (b) [2]

Today, Croatian motorway network is 1260.5 km long and 294 km of motorway per million inhabitants puts Croatia at very top of motorway network developed countries in Europe [2].

## 2 Corridor Vc and A5 motorway

Due to its auspicious traffic position to the main European transport routes, Croatia is divided by the pan-European multi-modal corridors: Corridor v (its Vb and Vc routes) and Corridor x (its main and Xa route). Figure 2 shows European traffic routes passing Croatian territory defined in Helsinki in 1997.



**Figure 2** Routes of European traffic corridors passing Croatian territory [1]

Beli Manastir–Osijek–Svilaj motorway, designated as route A5 is a part of the International Pan-European Corridor Vc that connects North Europe with the Adriatic Sea. This part of corridor is passing through two parts of eastern Croatia very different in macro-relief and climate:

east-Croatian lowland and Slavonian Posavina with Požega valley. The specific feature of this section is its transverse position due to which it intersects a number of state, county and local roads, two routes of existing railway lines (the main railway line Savski Marof-Zagreb-Tovarnik and Class I railway line Varaždin-Koprivnica-Osijek-Dalj) and it also intersects two rivers, Sava and Drava with the existing waterway routes. Another specific feature of the area route A5 is passing is its extremely rich archeological, cultural and historical heritage. Namely, Baranya region has a huge tourist potential and offers many facilities such as pure, intact nature and ethnic richness regarding the specific impact of the multi-ethnic nations who lived in this area and whose customs and values are cherished for centuries. In this area, there are also protected natural values such as Nature Park Kopački rit. This world famous wetland reserve formed at the confluence of Drava and Danube, with flood area of about 17 000 ha is a true ornithological paradise with over 270 birds species and it is added in the list of internationally important wetlands.

A route of the Corridor Vc passing through the Republic of Croatia is divided into 6 sections. Five of them passes through Slavonia and Baranya and are designated as route A5 while sixth section passes through south Dalmatia and is designated as route A10.

First section of route A5, Đakovo-Sredanci was opened to traffic in November 2007 in total length of 23.0 km. The second section, Osijek-Đakovo was opened to traffic in April 2009 in total length of 32.5 km. Building of the Drava Bridge represents construction beginning of longest unfinished section Osijek-Beli Manastir in length of 24.6 km. After complete of that section, the shortest section Beli Manastir-Hungarian border in length of only 5 km is to be built. In September of 2011, works on the section Sredanci-B&H border started and the end of the works is planned in 2013th. This section in total length of only 3 km is one of the most expensive ones because of 6 facilities, including complete construction of Svilaj border crossing which must be constructed according to Schengen conditions and bridge over river Sava which is to be financed jointly by Croatia and B&H [4]. Figure 3 presents motorway A5 divided into sections according to the time of opening to traffic [3].



Figure 3 Sections of A5 motorway [3]



To achieve its full potential, route A5 needs to be connected with sections of Corridor Vc in Hungary and Bosnia and Herzegovina. On the Hungarian side, motorway has come to town of Bóly and the rest of 19 km long section to Croatian border is planned to be finished until the end of 2013 [5]. Through Bosnia and Herzegovina, around 40 km of motorway has been finished and until the end of 2013 it is planned for new 80 km of motorway to be opened to traffic [5]. Even though route A5 passing over lowland part of Croatia, it is designed with significant number of facilities: 23 overpasses, 3 game crossings, 1 viaduct, a number of culverts and 17 bridges [1] among which it is worth mentioning the Sava River Bridge and the Drava River Bridge which main characteristics will be described.

### 3 The Drava River Bridge

Bridge over river Drava is located between two suburban communities, Josipovac and Petrijevci so the number of factors influenced on its disposition [6]:

- navigation and navigation clearance conditions ( waterway width of 50 m and height of 5.25 m);
- river Drava inundation width (3100 m at the bridge location);
- Vučica riverbed;
- flood embankment;
- location of the future hydroelectric power plant which partition profile need to be built downstream of the bridge so the bridge will be crossing over dam lake;
- nature preservation conditions.

Designing this bridge, few conceptual designs have been made [3]. First solution represented simple, customary design of a bridge in lowland while the other represented more attractive design, visually more impressive. Figure 4 presents first, ordinary bridge design and figure 5 presents future the Drava River Bridge.

Bridge is designed as a cable-stayed bridge with composite steel structure. Riparian bridge width is  $2 \times 13.2$  m due to which left and right roadways are on separated facilities and on the main span they are on the same facility, width of 28 m [6].

Plan view of the bridge starts with curve radius of 4000 m which continues into the transition curve length of  $L=200$  m ( $A=894.43$  m), straight line length of 1055.68 m, another transition curve with length of  $L=200$  m and it ends with curve of 4500 m radius [6]. Bridges vertical alignment is conditioned by navigation clearance so it is designed with vertical convex curve, tangents grade of 0.61%.



Figure 4 One of the bridge conceptual design solutions [3]



Figure 5 Appearance of the future Drava River Bridge [7]

One motorway roadway is consisted of 0.5 m marginal strip, two traffic lanes width of 3.75 m with marginal strip of 0.2 m and stop lane of 2.5 m width. Traffic bridge surface is extended for a further 0.5 m for each side, concrete path of 0.25 m and protective steel fence of 0.4 m width and height of 1 m [6]. Pavement transverse gradient is 2.5%, double sloping and constant.

The main bridge span is consisted of steel beam, reinforced concrete pylon and tie rods. Bearing steel beam is composited with reinforced concrete deck slab. Two reinforced concrete pylons are later A shaped, rectangular cross sections structures which are slightly widens towards the top and based on two groups of bored piles, 25 piles in each group, diameter of 150 cm and length of 19, 22 and 25 m. On each side of the pylons, there are two rows of 10 tie rods consisted of 20–60 cables [6]. Bridge has a total of 45 groups of concrete columns (2 or 3 columns in a group, different in cross section shapes) and columns which are positioned along the river bed are designed with granite stone facing for the protection of floating objects such as ice, branches and nozzle sandblasting [6].

Over the concrete deck slab, asphalt pavement construction is designed with 4.5 cm thick Splittmastixasphalt SMA 16, 5 cm thick binding course vs 16 and one-layer bituminous strip waterproofing [6].

Surface water reception and drainage is designed with two-part gully with the ability of collecting seepage water. Water from the gully goes by connecting pipes to the drain pipes, which are connected to the manhole nearest to the bridge.

Construction of this 2485 m long bridge started in July, 2011 and currently construction of piles are in progress (figures 6 and 7). The beginning of a construction works on this almost 950 million kn worth bridge, with a contract time of 30 months marked the beginning of construction works on a longest (24.6 km long) unfinished section of A5 motorway, Beli Manastir–Osijek.



**Figure 6** Construction works on the Drava River Bridge



**Figure 7** Construction site on the Drava River Bridge

## 4 Significance of motorway A5 and the Drava River Bridge

Motorway construction has both, positive and some negative effects for a society.

First of all, modern road network is one of the main prerequisites for the sustainable economic development. Beside the facts of faster, safer and more comfortable travel between countries and regions, during motorway construction increased demand for the construction materials and services are great impulse to the construction sector, locally and nationally and it has a great economic contribution to a region where the motorway passes along.

Motorway A5 is designed as traffic 'spine' of eastern Croatia which connects it with the rest of the country, as with a Europe. It represents precondition for of economic, tourist and cultural development of this region as for the whole country.

The main negative impact is increased need for financial resources, first for its construction and then for its management, maintenance and rehabilitation which in this times of crisis is a huge burden to society. Another negative impact is its influence on the environment since the construction of a motorway may drastically affect the landscape and disrupt the natural balance between animal and plant life. But despite that, there are much more positive influences on the society of motorway construction and modern technologies of road construction are making huge contribution in reducing earlier mentioned negative impacts.

Since the first section of A5 motorway has been open to traffic, the number of vehicles is in constant increase. In the first seven months of 2011, 371 400 vehicles has passed A5 motorway [8] and in the first six months of the same year the increase of 3.36% in toll collection has been recorded in reference to the same period of 2010 [4]. During the whole 2011, total of 655 410 vehicles has passed A5 motorway [4]. To full fill its full potential, A5 motorway need to be finished; it needs to be connected with the Hungarian and Bosnia and Herzegovina border and construction of the Drava River Bridge is a next step.

### References

- [1] Crnjak, M.; Puž, G.; Marić, A. & Čleković, V.: Hrvatske autoceste, Hrvatske autoceste d.o.o., 2008.
- [2] Puž, G.; Tkalčić, D.; Duplančić, D. & Furdin, M.: Razvitak autocestovne mreže Hrvatske, 5. Hrvatski kongres o cestama, Cavtat-Dubrovnik, pp. 88, 2011.
- [3] Crnjak, M; Brnić, B. & Puž, G.: Projektiranje i izgradnja autoceste na Vc koridoru u Republici Hrvatskoj, 1. BH Kongres o cestama, Sarajevo, pp. 243-254, 2007.
- [4] Župan, S.: Za 3,2 kilometra autoceste 187 milijuna kuna zbog 'Schengena' na Svilaju, [www.glas-slavonije.hr](http://www.glas-slavonije.hr)
- [5] Kuštro, D.: Za dvije i pol godine Slavonci će novim mostom preko Drave, [www.glas-slavonije.hr](http://www.glas-slavonije.hr)
- [6] Most preko rijeke Drave, detailed design, Institut IGH d.d., 2011.
- [7] Most preko rijeke Drave-brochure, Hrvatske autoceste d.o.o.
- [8] Župan, S.: Slavonikom ljeti svakoga dana projuri 2000 vozila, [www.sib.hr](http://www.sib.hr)





## ÖBB RAILWAY BRIDGE CONSTRUCTION – CHALLENGES IN USING THE EUROCODES

Thomas Petraschek

ÖBB Infrastruktur AG, Track Integrated Management, Austria

### Abstract

The so called Steyrthal Bridge is situated in the Phyrn area of Upper Austria. It is a steel bridge with three single spans of approximately 30 m, 80 m and again 30 m. In addition it has two arches built as natural stone masonry both at the beginning and at the end of the structure. The so called Brunngraben Bridge, a single span steel bridge, is situated in the middle Enns valley in Upper Styria.

Both bridges are railway bridges and are part of the Austrian railway network, to be more precise of the railway line Linz – Selzthal. Due to problems with the load bearing capacity when the track classification of the named railway line is raised to class E in both cases a new building is obligatory.

Since the erection of both constructions must take place with active railway operation, quite special boundary conditions must be considered. For example these can be the adherence to the clearance beneath the superstructure or also the available period of stopped active railway operation.

For Steyrthal Bridge an additional special problem must be considered. The planned overall length of the Steyrthal Bridge will be approximately 185 m. The superstructure should be a continuous beam steel–concrete composite bridge with three gaps. In spite of the big total length of the superstructure no rail expansion joints should be used.

All these points were a quite special challenge for the planning. How this was solved with an extremely innovative construction for the Brunngraben Bridge and which lessons we have learnt with adoption of the Eurocode for the combined response of railway track and superstructure will be part of this paper.

*Keywords: bridge, Eurocode, combined response of structure and track, maintenance, execution class*

### 1 Introduction

The single track railway line Linz – Selzthal between Linz, the capital of Upper Austria, and the northern region of Styria was established in the very early of the twentieth century. Until 2016 this railway line shall be toughened up in such a way that the permanent execution of heavy load traffic will be possible.

Situated in km 65,622 there is a large viaduct running across the river Steyr, which is retained in this area. Situated in km 100,144 there is a small bridge across an agriculture way and a very small stream. In both cases within the planning process the Eurocode set some special challenges due to boundary conditions defined for their renewing.

## 2 Steyrthal Bridge

### 2.1 General

The existing railway bridge Steyrthal was erected with three single span steel superstructures in the year 1905 and is so now more than 100 years old. The middle field has an effective span of about 80 m and bypass the storage lake of the river Steyr. One of the main posts is founded in the storage lake. The two neighbouring fields of the middle field have an effective span of about 30 m. They are stretched towards the embankment on both sides of the river Steyr. Due to very bad maintenance condition the existing structure shall be replaced by a new one.

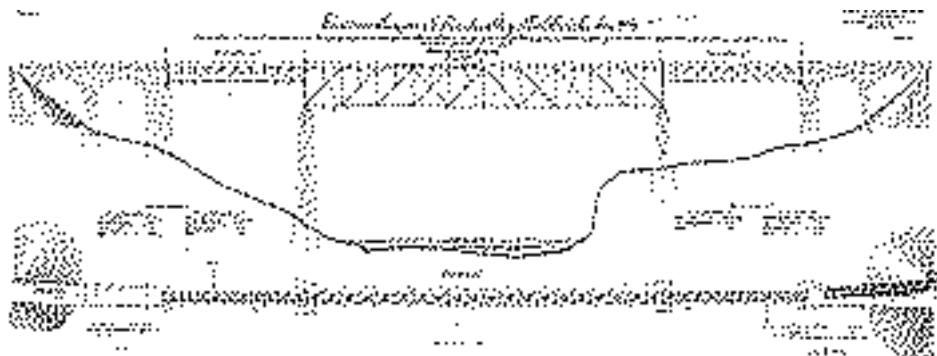

Figure 1 Longitudinal cut of existing Steyrthal Bridge over river Steyr.

Since the erection of the structure must take place with active railway operation, the solution is to erect a structure beside the existing one. So afterwards also the existing line shall be replaced in optimized quality.

One of the challenges is to find a design of the structure with avoiding rail expansion joints, which not only lead to very high maintenance costs but also to problems in railway operation. Therefore you have to fulfil permissible additional rail stresses due to the combined response of structure and track to variable actions, given in EN 1991 'actions on structures', part 2 'traffic loads on bridges' [2].

## 3 Basic principles for combined response of structure and track

When starting the calculation there are parameters to specify affecting the combined response of structure and track like configuration of the structure, configuration of the track, properties of the structure and properties of the track.

This means also to fix the longitudinal load–displacement behaviour of the track or the rail supports, the kind of used rail with values for the tensile strength and the minimum value of track radius. In the case of Steyrthal Bridge there are all parameter values beyond the range of values given not only in the Eurocode but also in the National Annex. Where it was necessary the boundary conditions were co–ordinated with the experts of the Austrian Railways. In the end the Austrian Railways as relevant authority gave the agreement.

### 3.1 Conceptual design

With beginning of the design the first attempt was to replace the existing steel framework bridge with a similar construction. It should be a modern designed steel–framework composite bridge with concrete deck outlined as a three field continuous beam. But this design did not fulfil the requirements for the combined response of structure and track. Some more designs

were investigated but with no one it was possible to avoid the rail expansion joints. In the end it was clear a very high horizontal stiffness is required and so finally the design process ended up with a concrete arch.

### 3.2 Calculation of combined response of structure and track

The actions which shall be taken into account are traction and braking forces, thermal effects according to EN 1991-1-5 in the combined structure and track system, classified vertical traffic loads and other actions such as creep and shrinkage according to EN 1992-1-1 [2].



Figure 2 Three-dimensional model of concrete arch structure with rails.

In context with the combined response of structure and track for creep and shrinkage the time of space closure of the rail is of highly importance because only beginning with this moment there are forces brought forward to the rail. In the calculations it was decided to fix an age of the concrete of 6 month or 180 days when closing the space between the rails.

Together with the rails the structure was modelled as three-dimensional problem. Corresponding to designations in literature the rail was considered in the static model in an area up to 90 m in front of the superstructure and also after the superstructure [3]. The in longitudinal direction existing load-deformation behaviour of the rail track and also of the rail fastening system was put into effect with nonlinear springs. There was a differentiation between loaded and unloaded rail track. The foundation of the structure with abutments and piers was integrated into the static model with vertical, horizontal and torsion springs corresponding to the designations of the soil expert. Again for the spring stiffnesses there was a differentiation between static and dynamic loading.

With consideration of all the given points and with a series of investigated variations for the arch bridge the proof of combined response of structure and track according to Eurocode was finally fulfilled in a positive way. There was no more any need for rail expansion joints. Substantial was the possibility in modelling the soil properties with nonlinear stiffness's near to the reality including differentiated specifications for varied actions. Results of the calculations are additional rail stresses due to combined response of structure and track to variable actions after superposition of the single rail stresses [4].



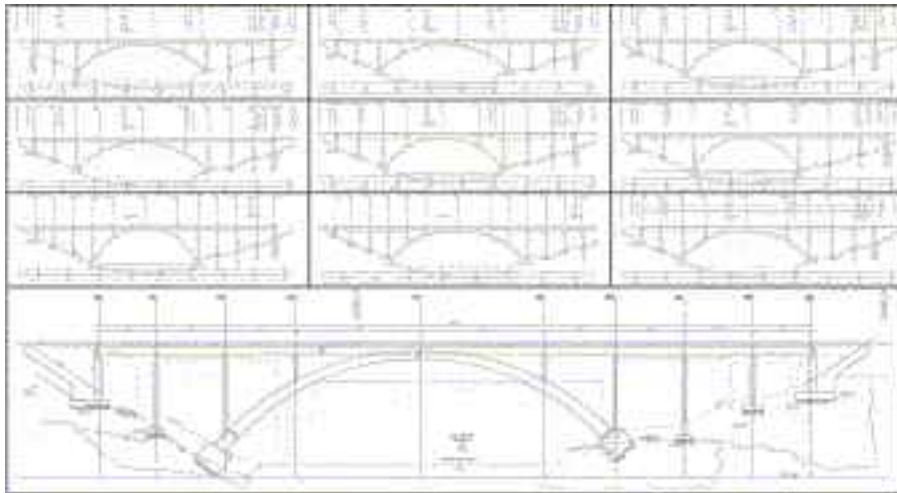

Figure 3 Investigated variations for the arch bridge with final structure.

## 4 Brunngraben Bridge

### 4.1 General

The so called Brunngraben Bridge, a single span steel bridge, was to be replaced with a new building due to problems with the load bearing capacity when the track classification of the railway line Linz – Selzthal is raised to class E.

Since the erection of the construction must have taken place with active railway operation, quite special boundary conditions must have been considered like adherence to the clearance beneath the superstructure and the retention of the existing elevation of the rail track, but also the substitution of the open rail track with a ballast substructure and stopped active railway operation of only 6 days.



Figure 4 Longitudinal cut of new Brunngraben Bridge with given boundary conditions.

## 4.2 Design, statics, non-deformability and secondary moments

Before the conceptual design process started some initial data were indicated. One was that the design shall be a single-way track trough bridge with minimized overall size considering the structure clearance given in the technical guideline for railway bridges.

Overall seven cross sections had been investigated in a study concerning ultimate, serviceability and fatigue limit states as defined in the latest European Standards. Particular attention was laid on the design of the bottom plate as deck plate with 120 mm width and on the stability of the two main beams. Result of the study was a cross section, which is extremely convenient for a structure type with initial data as given before.



Figure 5 Principle cross section of new Brunngraben Bridge [5].

Following, this cross section was investigated by an own master statics, considering the ultimate, serviceability and fatigue limit state properties. The internal forces were calculated with warping torsion in the tenth points of the span under consideration of the load cases for railway bridges given in EN 1991-2 [1].

For creating the load groups 11 to 17 defined in the EN 1991-2 the dynamic factor  $f_2$  and the classification factor  $a$  have been considered. The different combinations for the ultimate, serviceability and fatigue limit states were defined according to EN 1990. To get the fatigue loads, the adaptation factor  $I$  was used. The effects of shear lag of wide flanges, especially of the deck plate, were considered by effective widths.

Based on the internal forces calculated with the named load combinations and section properties, the stresses were computed. The normal stresses resulting from the normal force and the bending moments as well as the shear stresses resulting from the shear forces and the primary torsional moment had to be considered.

Concerning the calculation of the internal forces due to warping torsion, there also had to be considered normal stresses resulting of the bimoment of warping torsion and, obviously, shear stresses due to the secondary torsional moment. Finally the equivalent stress according to Mises' yield hypothesis had to be compared with the limiting stress values in certain points of the cross section.

Concerning the serviceability limit states, the resonance frequencies, the vertical deflection for the verification of the driving comfort and the deflection of the simple beam, the maximum twisting of the structure on a length of 3 m and furthermore the horizontal deflection and resonance frequency were confronted with the permitted values.

Two special investigations for the trough bridge type were necessary. The first one was an investigation on the contour accuracy of the cross section because of the lack of stiffeners between the two transversal girders at the end supports. The second one was an investigation on the cause and effects of the 'secondary moments'. The deck plate with a width of 120 mm is elastic end-restrained to the web of both main girders. With regard to the loading of the plate a small elastic restraint is of negligible magnitude, since the activated very low hogging moments have no real effect on the sagging moment of the plate. However, this is not valid for the loading of the web in the region of the connection plate to web.

### 4.3 EN 1090–2 and execution classes

Since 15th September of 2009 in Austria the global family of standards for steel constructions is basically complete with the issue of EN 1090-1. Now one has on one side the Eurocodes, on the other side the material standards and in the middle as a principal item EN 1090 as execution standard.



Figure 6 Global family of standards for steel constructions.

Here new territory began. Suddenly there must be specified additional information that is required for execution of the work to be in accordance with EN 1090-2 [6]. Furthermore every component must be classified in execution classes with range from EXC1 to EXC4.

The determining of an execution class is a multistage process. First step is a classification in consequences classes. The range runs from CC1 to CC3 and is deposited with description and examples. The consequences classes also are coupled directly with the reliability classes RC1 to RC3.

And here it is extremely important to note: A design using EN 1990 with the partial factors given in annex A and EN 1991 to EN 1999 is considered generally to lead to a structure with a reliability index value equal or greater then 3,8 for a 50 year reference period. This corresponds to a RC2 requirement. That means not more but that a classification in a higher consequences class has no immediate effects on the results, for example, of a static calculation.

The choice of the consequences classes should be made only based on this knowledge. In reality as values for decision only a few parameters remain such as for example the time to restore the availability of a railway line in accordance with its importance or the accessibility of locations, which are of absolute importance for the structural safety of a structure.

Thus, the Brunngraben Bridge would have to be classified in consequences class CC2. However, the longitudinal fillet welds for connecting the bottom plate to the two main girders are no longer accessible for expert opinion due to the existing ballast substructure. Therefore, here inspection level IL3 was chosen by the öBB concerning the inspection during execution. By linking with the associated reliability class RC3 the result was a classification in consequences class CC3.

Until now you have moved in the content of Annex B of EN 1990. Now you jump over in Annex B of EN 1090-2 and determine in a second step the service categories and the production categories. With first the type of actions is considered, with the second steel grade products and assembling.

The Brunngraben Bridge is designed for fatigue actions according to EC3, so the service category is SC2. Due to components manufactured from steel grade products below S355 and that they are assembled by welding exclusively in the metal working plant the production category is PC1. Thus, for the Brunngraben Bridge the determination of the execution class would be finally possible: CC3 with SC2 and PC1 result in EXC3. However, but this was not the case. The tendering for the structure must have been done with EXC4. Reason were the technical contract conditions for steel structures rvs 08.08.01, which automatically demand EXC4 for railway bridges independent of the way to determine the execution class introduced before.

## 5 Conclusions

For the Steyrthal Bridge there were three controlling points in fixing the design of the construction. The first one is the abandonment rail expansion joints. This problem specification was in fact the determining factor for the design of the construction and led in the end to a concrete arch bridge. The choice of the design of the arch was not only based on the thrust line but was also carried out under consideration of optimizing the tensile stresses in the rail due to cleverly elected horizontal stiffness and deformability behaviour. The third one was to have a bridge structure which is harmonically integrated in the characteristic landscape of the Phyrn area in Upper Austria.

For the Brunngraben Bridge in the end the main point was the application of EN 1090. Here not only the Execution Classes are regularly subject of protracted discussions. Generally there is a lack of will to deal with the requirements of EN 1090. In part various requirements are quite simply ignored deliberately. And no one insists on the implementation, possibly due to lack of knowledge.

The ÖBB had already very early consisted in application of existing Eurocodes in the design of steel structures. The gains in experience with a view to the results are to be valued as throughout positive.

## References

- [1] ÖNORM EN 1991-2: Eurocode 1: Action on structures – Part 2: Traffic loads on bridges, Austrian Standard Institution, Vienna, Austria, 2004.
- [2] ÖNORM EN 1992-1-1: Eurocode 2: Design of concrete structures – Part 1-1: General rules and rules for buildings (consolidated version), Austrian Standard Institution, Vienna, Austria, 2009.
- [3] DIN Fachbericht 101: Einwirkungen auf Brücken – Actions on bridges, Deutsches Institut für Normung, Berlin, Deutschland, 2009..
- [4] Ruge, P., Birk, C., Muncke, M., Schmäzlin, G.: Schienenlängskräfte auf Brücken bei nicht-linearer Überlagerung der Lastfälle Temperatur, Tragwerksbiegung, Bremsen (Chapter), Bautechnik 82, Springer-Verlag, Berlin and New York, pp. 818-825, 2005.
- [5] Fink, J., Kuss, St.: New railway trough bridges – an apparently easy bridge type, 6th International Conference on Bridges across the Danube, Budapest, pp. 177-188, 2007.
- [6] ÖNORM EN 1090-2: Execution of steel bridges and aluminium structures – Part 2: Technical requirements for steel structures, Austrian Standard Institution, Vienna, Austria, 2009.





## SOME EXPERIENCES IN PRODUCTION OF CONCRETE MIXES DESIGNS FOR CONSTRUCTION OF CORRIDOR X IN SERBIA

Zoran Grdić<sup>1</sup>, Gordana Topličić–Ćurčić<sup>1</sup>, Nenad Ristić<sup>1</sup>, Iva Despotović<sup>2</sup>

*1 Faculty of Civil Engineering and Architecture in Nis, Serbia*

*2 University College of Applied Studies in Civil Engineering and Geodesy in Belgrade, Serbia*

### Abstract

The construction of road infrastructure of the Corridor x through Serbia, according to design documents, required concretes of a variety of classes and special properties. Depending on the type of structures and their structural elements (piles, bridges, tunnels) the concrete class ranged from C 25/30 to C 45/55. The special properties required were: resistance to frost, resistance to simultaneous action of frost and defrosting salts and water tightness. Overall, those are concrete mixtures which can be designed relatively easily with quality materials. In practice, however, a problem occurred, as the contractor required using of the materials, i.e. aggregates, from the nearest locations. Experience acquired in those concrete mixes design once again confirmed how large impact aggregates have on concrete properties. As a result, many aggregates from the local screening plants were not adequate choice in mixing of the concretes having the required properties. The paper presents the mix designs for concrete, designed with various aggregates, as well as the properties of concrete in fresh and hardened states.

*Keywords: aggregate, mix design, fresh concrete, hardened concrete*

### 1 Introduction

Aggregate, on average, occupies around three quarters of concrete volume, and therefore impacts the properties of fresh and hardened concrete by means of its own characteristics. The aggregate's share in the cost of 1 m<sup>3</sup> of concrete is around 50%, the river aggregate being less expensive than the crushed one. Lately, there is a tendency to decrease and limit borrowing of aggregate from the river courses for hydrological, environmental and other reasons.

The properties of aggregate tested for the purpose of proving its suitability for concrete mixing are numerous and in general, they can be divided into: mineralogic-petrographic, chemical, physical and mechanical.

One of the earliest parameters of aggregate quality that draw attention of numerous researchers (Fuller, Bolomey, Fourie, Leviant, Popovics, Valet, EMPA Institute etc.) is the particle size distribution. For production of concrete, in principle, the grading has to be chosen in such a way so that fine particles fill in the space between the coarse grains, then even finer particles fill in the remaining space and so on approximately until the cement fineness is reached. Cement paste is supposed to fill in all the remaining space and to envelop the aggregate grains in a thin film. After hydration, the cement rock should bind all the aggregate grains into one compact mass. Prescription of a single 'ideal' grading curve is exaggeration, and it is known that grading curves lie in a wider area [1].

Mineral aggregates used for concrete mixing are considered basically inert, that is, chemically inactive in concrete. However, they can sometimes contain substances which are detrimental

for concrete, if their amount is above the certain limits. Such substances are called harmful matters.

One of the harmful matters which is very often present to a certain extent, is the fine particles. This term comprises those particles of aggregate passing through the sieve with 0.09 mm square mesh openings. Fine particles in aggregate can be present in dispersed – unbound form, as clay lumps or as an layer ('clay film') on the surface of coarse aggregate grains. As for the content of fine particles, the crushed aggregate can very often be less favorable than the river one, because in the crushing process a large quantity of such particles is generated – rock flour, which adheres to the surface of coarse grains, or is simply present in the unbound state. If used for production of ordinary cement concretes, the crushed aggregate needs to be washed [2, 3].

Excessive presence of fine particles can affect workability of fresh concrete, contribute to increased shrinkage of concrete, reduce its durability, reduce the content of air entrapped in concrete [4]. The aggregate whose surface is to a considerable extent enveloped by the layer of fine particles is not favorable for production of cement concrete because there will be no sufficiently strong bond between the cement rock and the aggregate grains which results in lower strength of concrete. Simultaneously, at the interface between the aggregate grains and cement rock a transit zone is created, containing multitude of capillary pores [5]. The water transport occurs through the transit zone, or in other words, the concrete is water permeable. Such concrete has low strength to other adverse impacts: freezing and thawing, defrosting salt action, chemical aggressiveness etc. Fine particles have large surface and they are capable of binding a large quantity of water. For this reason, the aggregate which contains a large quantity of fine particles requires a larger quantity of water for the purpose of making the concrete of identical consistency in respect to the clean aggregate. The excess water which does not take part in cement hydration evaporates later, and due to this the concrete has higher porousness, lower density, lower compressive strength and poorer other characteristics [6].

Porousness of the aggregate, its water tightness and absorption affect the potential of binding of the aggregate for cement paste, concrete resistance to frost action, chemical stability and wear resistance. Due to aggregate water absorption there is a certain loss of workability of fresh concrete mass, particularly in the first 15 minutes [7].

The results of aggregate tests by the Los Angeles method show high agreement with the achieved compressive strength of concrete and resistance of aggregate and concrete to wear. For these reasons, the resistance to simultaneous crushing and wear in the Los Angeles machine was determined for all the aggregates used for the making of concrete. In this paper is presented the experience acquired in designing concrete mix designs for concretes intended for construction of structures (piles, bridges, tunnels etc.) of Corridor x (highway E 75).

## 2 Materials used for making concrete

It should be emphasized at the outset, that the choice of the material for making concrete was made by the party that ordered the mix designs, which was primarily concerned by the financial considerations. For this reason, the basic choice was focused on the closest screening plants, i.e. quarries. The list of aggregates which were tested, and which underwent the preliminary laboratory tests is provided in table 1.

Regardless of the found deficiencies of certain aggregates, at the contractor's demand, all the requested concrete tests were carried out. The final concrete mix designs were made with the aggregate no. 5 and no. 4 with certain corrections, table 1.

**Table 1** **Table 1**  
The list of aggregates used for making concrete.

No.	Aggregate name	Aggregate type	Found Deficiencies
1.	Europetrol, Vranje	Screened from the South Morava river	Coefficient LA 38, aggregate grain surface enveloped by fine particles
2.	Momin Kamen, Vladičin Han	Screened crushed dacite	High porousness (above 5%), water absorption around 2%
3.	5D, Vranje	Screened from the South Morava river	None, small capacity of the separation facility
4.	Saba Belča, Bujanovac	Screened crushed limestone	Poor particle size distribution, high content of fine particles
5.	MD GIT, Brestovac near Niš	Screened from the South Morava river	None (selected for production of concrete)

For making concrete, the following CEM II cements were used: Titan PC 20M(V-L) 42.5N, Titan PC 35M (V-L) 42.5R and Titan PC 20S 42.5N. All cements met the requirements in terms of suitability for making concrete according to EN norms and they had fairly uniform characteristics. Concrete for construction of structures along the highway, apart from the required compressive strengths (c 25/30 to c 45/55) had to have other properties: capacity of maintaining long term consistency in summer conditions (S<sub>3</sub> to S<sub>4</sub>), resistance to frost action (M<sub>100</sub> to M<sub>150</sub>), resistance to simultaneous action of frost and defrosting salt and resistance to action of pressurized water (V<sub>3</sub>). In relation to that, numerous chemical admixtures by various manufacturers have been tested, as given in the table 2. As in the case of other materials, the choice of chemical admixtures was made by the contractor. After all tests, the chemical admixtures chosen for making concrete were Sika Viscocrete 3070 and Sika Aer.



**Table 2 Table 2**  
List of chemical admixtures used for making concrete.

No.	Manufacturer	Chemical admixture designation	Primary purpose (according to the manufacturers' technical specifications)
1.	Sika	Viscocrete 4000 BP (Hyperplasticizer)	Maintaining of consistency in extreme summer conditions, higher final strengths
		Viscocrete 3070 (Hyperplasticizer)	For moderate maintaining of consistency and transport, for summer season, for waterproofing
		Sika Plast 20C (Superplasticizer)	For maintaining consistency and transport of concrete for application in summer season
		Sika Aer (Air entraining)	Increases resistance to frost and resistance to defrosting salt
2.	Ruredil	Ergomix 140 (Plasticizer)	Reduces water demand, increases compressive strength
		Monolit (Air entraining)	Increases resistance to frost and resistance to defrosting salt
3.	Isomat	Adium 130 (Superplasticizer)	Reduces water demand, facilitates longer maintain of consistency
		Porolit – LM (Air entraining, superplasticizer)	Reduces water demand, increase workability, increases frost resistance and resistance to defrosting salt
4.	Ading	Fluiding M1M (Superplasticizer)	For transport concretes, for concreting at high temperatures
		Poročinitelj (Air entraining)	Increases resistance to frost and resistance to defrosting salt

### 3 Properties of fresh and hardened concrete

Around 40 concrete mixtures were made. The most of them, as many as 23, referred to class c 25/30 concrete which except the required strength had to have certain previously mentioned properties. Fresh concrete underwent the slump test, density and entrapped air content, and the fresh concrete underwent compressive strength tests and the density. In table 3, there are concrete mixtures compositions, and in table 4 are provided some of the measured values of the properties of fresh and hardened concrete. In table 3, in column 1 there are ordinal numbers under which they were filed in the laboratory.

**Table 3 Table 3**  
Quantities of material in kilograms for 1 m<sup>3</sup> of class C 25/30 concrete.

No.	Type, number of fractions and quantity of aggregate	Quantity of cement and w/c ratio	Type and quantity of admixtures [% of cement mass]
237	Europetrol (4) 1845	380 0.44	Viscocrete 4000 0,8%, Aer 0,03%
238	Europetrol (4) 1845	380 0.44	Viscocrete 4000 0,8%, Aer 0,025%
239	Europetrol (4) 1845	380 0.44	Viscocrete 4000 0,8%, Aer 0,02%
243	Europetrol (4) 1845	380 0.50	Ergomix 140 1,2%, Monolit 0,1%
245	Europetrol (4) 1830	400 0.50	Viscocrete 3070 0,8%, Aer 0,015%
246	Europetrol (4) 1830	400 0.50	Viscocrete 4000 0,65%, Aer 0,015%
247	Europetrol (4) 1830	400 0.50	Ergomix 140 1,2%, Monolit 0,1%
258	Europetrol (3) 1780	390 0.50	Viscocrete 3070 (1,2%)
259	Europetrol (3) 1780	390 0.48	Ergomix 140 (1,4%)
260	Europetrol (4) 1820	400 0.50	Fluiding M1M 1,0%, Poroč. 0,09%
261	Europetrol (3) 1760	400 0.473	Fluiding M1M 1,2%, Poroč. 0,09%
262	Europetrol (4) 1830	400 0.50	Adium 130 0,7%, Porolit-LM 0,03%
263	Europetrol (3) 1760	400 0.498	Adium 130 0,7%, Porolit-LM 0,05%
268	5D (3) 1800	400 0.42	Viscocrete 3070 1,0%, Aer 0,015%
269	5D (3) 1760	400 0.45	Sika Plast 20C 1.6%, Aer 0,015%
270	Momin K. (3) 1810	380 0.486	Viscocrete 3070 1,0%, Aer 0,015%
271	Momin K. (3) 1740	400 0.55	Sika Plast 20C 1.2%
272	Momin K. (4) 1760	400 0.50	Viscocrete 3070 1,2%
273	Momin K. (3) 1740	400 0.534	Viscocrete 3070 1,0%
275	Saba Belča (3) 1735	400 0.513	Viscocrete 3070 0,85%
277	Saba Belča (3) 1736	400 0.501	Viscocrete 3070 0,85%, Aer 0,015%
278	MD GIT (4) 1800	360 0.462	Viscocrete 3070 0,8%, Aer 0,01%
281	Saba Belča (3) 1736	400 0.468	Viscocrete 3070 0,85%

**Table 4** Table 4  
Measured values of fresh and hardened class C 25/30 concrete.

Concrete mixture designation	Consistency class (slump)	Entrapped air content [%]	Density of fresh concrete [kg/m <sup>3</sup> ]	Compressive strength after [N/mm <sup>2</sup> ]
237	S3 (100 mm)	4.2	2410	41.1
238	S3 (110 mm)	3.5	2410	42.6
239	S3 (120 mm)	3.2	2410	42.3
243	S3 (100 mm)	4.5	2424	41.26
245	S4 (170 mm)	4.5	2406	40.0
246	S4 (180 mm)	4.6	2394	39.0
247	S2 (90 mm)	6.2	2354	35.8
258	S4 (190 mm)	-	2384	33.1
259	S4 (180 mm)	-	2399	33.1
260	S3 (120 mm)	2.6	2405	34.6
261	S1 (20 mm)	2.6	2404	38.1
262	S1 (40 mm)	2.5	2422	34.2
263	S1 (40 mm)	4.0	2388	30.7
268	S3 (130 mm)	4.5	2318	39.2
269	S1 (130 mm)	4.5	2302	31.0
270	0 mm	-	2314	49.9
271	S2 (60 mm)	-	2280	40.6
272	S4 (160 mm)	-	2322	35.9
273	S3 (110 mm)	-	2265	36.3
275	S4 (200 mm)	-	2357	44.7
277	S3 (150 mm)	4.5	2340	44.1
278	S4 (190 mm)	4.0	2300	38.1
283	S1 (40 mm)	-	2368	39.6

## 4 Discussion of obtained results

The majority of concrete mixes were made with river screened aggregate from the upper course of the South Morava river, Europetrol (table 3, no's. 237 to 263) screening plant. This aggregate had a number of deficiencies, of which high value of Los Angeles coefficient (38, grade 'B') and envelopment of aggregate grain surface by fine particles particularly stand out. Notwithstanding, the contractor insisted to make concrete mixes, as the screening plant was immediately next to the highway section under construction. Along with the previously mentioned elements, the concrete mixes were made with chemical admixtures of as many as four manufacturers (table 2). The reason for this was the contractor's attempt to find the least costly solution.

Due to the poor quality of the mentioned aggregate, the dosage of cement were considerably high, and the same holds for the dosage of chemical admixtures which was at the top recommended limits (regardless of the manufacturer). The concrete mixes which were made

with the dosage of cement of 400 kg/m<sup>3</sup> of concrete were intended for construction of piles, as required by the design documents.

Fresh concrete exhibited bleeding and quick loss of consistency. For many concrete mixtures, compressive strengths were not satisfactory after 28 days (less than 38 N/mm<sup>2</sup>). In terms of time, four months were spent for preliminary tests prior to rejecting the aggregate as a material suitable for production of concrete.

Afterwards, the screened river aggregate from the upper course of the South Morava river from the screening plant 5D, was sent to the laboratory, which met all the quality conditions. With this aggregate, in a very short time a concrete mix for construction of piles was made, with all the required properties (tab. 3 and tab. 4, no. 268). The problem, however, was not solved, because the screening plant turned out to have small capacity, which could not satisfy the dynamics of construction works.

For this reason, production of concrete mix designs continued, with the crushed screened dacite from the Momin Kamen quarry. This quarry was not operational for a number of years. Even though the required strengths could be obtained with this aggregate, it had been known that it had featured high porousness and insufficient resistance to frost action. There was a problem as well with the required (S<sub>3</sub> to S<sub>4</sub>) slump value. When such consistency was achieved, then the compressive strengths after 28 days were not satisfactory and vice versa. Eventually, the crushed screened limestone from the quarry Saba Belča and river screened aggregate from the medium course of the South Morava river MD GIT screening plant, of Breštovac near Niš were sent to the laboratory. The crushed limestone aggregate had a very poor particle size distribution (high share of finer or coarser grains in fractions), so by designing the fraction mix, this problem was somehow overcome. Fraction 0/4 mm was replaced by the corresponding fraction of the river aggregate. When making concrete c 25/30 with the river screened aggregate MD GIT there were no problems (tab. 3 and tab. 4, no. 278). Eventually, for making concrete for production of piles, crushed screened limestone was chosen, and for other structures, the screened river aggregate MD GIT.

## 5 Conclusion

On the basis of the experience acquired when designing concrete mix design for construction works of the section of the Corridor x highway, a number of conclusions was drawn.

The contractor requested a large number of preliminary tests in concrete works preparation period, which is extraordinary compared to the requests of national (Serbian) companies. The aim of this action was to find out the most cost-efficient solution – concrete mix design. The activities related to production of mix designs, which have been presented in this paper, confirmed earlier theoretical and practical knowledge that the aggregates which have as much as one property which does not meet the prescribed quality requirements cannot be used for making a good and cost-efficient concrete. This assertion is confirmed by the fact that in almost all presented examples the dosages of cement and chemical admixtures were extraordinary high.

The chemical admixtures irrefutably have a large impact on properties of fresh and hardened concrete. However, in the situation when one of the concrete components, in this case aggregate, does not meet the prescribed quality requirements, the effects of chemical admixtures are severely limited. The quantity of chemical admixture is around the maximum recommended limits, with no prominent or expected effect.

The final conclusion, which is generally known, is that the economically acceptable concrete of required properties can be obtained only when all the concrete components meet the prescribed quality conditions.

## References

- [1] Neville A.M.: Properties of Concrete, Fourth and Final Edition, Standards updated to 2002, Pearson Education Limited, Edinburgh Gate, Harlow, Essex CM20 2JE, England, 2005.
- [2] Newman J., Choo B.S.: Advanced Concrete Technology – Constituent Materials, Butterworth-Heinemann An imprint of Elsevier Linacre House, Jordan Hill, Oxford OX2 8DP 200 Wheeler Road, Burlington MA 01803, 2003.
- [3] Topličić-Ćurčić G., Grdić Z., Despotović I., Ristić N.: Influence of crushed stone aggregate sort on concrete consistency, Facta Universitatis, Series Architecture and Civil Engineering, Vol.8, No 1, University of Nis, 2010.
- [4] Powers T.C.: The Properties of Fresh Concrete, John Wiley & Sons Inc., New York – London – Sydney – Toronto, 1968.
- [5] Mindess S., Young J.F., Darwin D.: Concrete, Second Edition, Pearson Education, Inc., Upper Saddle River, NJ 07458, 2003.
- [6] Bloem D.L., Gaynor R.D.: Effect of Agregate Properties on Strenght of Concrete, Acı Journal, Vol. 60, No. 10, 1963.
- [7] Grdic Z.: Tehnologija betona, Građevinsko-arhitektonski fakultet Univerziteta u Nišu, 2011.



## DEMAND FOR WAYSIDE TRAIN MONITORING SYSTEMS IN THE NETWORK OF SLOVENIAN RAILWAYS

Andreas Schöbel<sup>1</sup>, Danilo Vek<sup>2</sup>

<sup>1</sup> Vienna University of Technology, Institute of Transportation, Austria

<sup>2</sup> Ministry of Transport, Slovenia

### Abstract

The Ministry of Transport, Railways and Cableways Directorate, Sector for Investment and Upgrading engaged the Vienna University of Technology, Institute of Transportation, Research Centre for Railway Engineering to carry out two studies on the demand of wayside train monitoring systems in the network of Slovenian Railways (sz). One is covering the requirements for weighting systems and flat wheel detection (so called axle load checkpoints) and the other one for hot box detection systems. This article contains the results for both studies. It deals with the demand analysis based upon the accident data base of Slovenian Railways (sz) under consideration of the defined protection goal. The technical requirements for the sensor systems are also listed. The choice of location is done by an analysis of risky elements in the network of Slovenian Railways (sz). Finally it gives an outlook on recommendations for the practical implementation.

*Keywords: wayside train monitoring systems, hot box detection, axle load checkpoints, risk analysis*

### 1 Introduction

The following fault states in railway operation [2] were previously defined by the ministry of transport and had to be considered in this work:

- Faulty brakes: Due to failures in the control value of the pneumatically driven brake system, the brake shoes or blocks of an axle may not be released. In the majority of cases, the friction is not big enough to block the whole axle. Hence, there will be a continuous heating of the brake discs (for disc brake systems) or of the wheel (for block brake systems). Moreover, the blocked brakes can cause fires in the bogie construction due to sparks. These sparks can also enkindle vegetation besides railway lines. In the residual cases of massive friction the axle won't rotate and will sliding on the rails.
- Faulty box: As the result of missing lubrication or of mechanical damage of parts of an axle bearing, the increased friction heats the bearing during the drive. Hence, a good and proven indicator for damaged bearing is the temperature of the box itself.
- Flat wheel: The term defects describe many different irregularities, which can occur on the running surface of a wheel. For instance, flat spots are flattenings of the round wheel, whereas reweldings are similar to little metal bumps. Beside there are out-of-roundnesses, and material eruptions. All lead to short force peaks with increased amplitudes during the run of the train and effect additional stress in the rail and in the wheel. Thus, such wheels can damage the rail and should therefore be rejected.
- Overload: If the load of the wagon is too heavy, all underlying components of the wagon (body, bogie, axles, wheels and the rails) are overstrained. This overloading state results in increased wear and should be prevented.

- Axle breakage: There can be two types of broken axles identified. A cold axle breakage is influenced by metallurgic reasons (material defects, etc.). In contrast to the cold type, if there is a massive heat exposure, the properties of the material can be affected negatively (warm axle breakage). In combination with high mechanical stress, such a weakened axle can break and the guidance property, which is obligatory for rail-bound traffic, is lost.
- Displaced or unbalanced cargo (left/right, back/front): If cargo is not fixed correctly, the load can be displaced during the run of the train. Similar can happen, if the condition of the fixing material is bad and thus, the fastener can disrupt. Moreover some cargo car might be unbalanced due to wrong placement of cargo in the car.

## 2 Demand Analysis

Generally the estimation of risk is a difficult task because an accident data base only provides indicators. Dangerous situations in operation which did not lead to an accident are normally not stored in an accident data base, although these situations are important for the risk estimation. To compensate this missing information the judgement of operational experts is very important. Of course, the first task is always to have a closer look on the accident data base if there are reliable values available for the risk estimation. Therefore it is necessary to know details about the history of an accident. Sometimes a predefined categorisation is not suitable for a specific accident. On the other hand the accident data base gives a first indicator for the potential risk. The specific view on the accident data base is given by the aspect if it is possible to recognise one fault state by some wayside monitoring system. So the fault states which are in the focus of such an analysis must be car related and appear for a certain time to be measured by some equipment [4].

The calibrated risk matrix can be used to put in the car related fault states which may destroy the infrastructure of the infrastructure manager. Therefore it is necessary to check if all well known fault states are considered. For each fault state an analysis based upon the national accident data base was carried out to estimate the risk caused by each fault state for the infrastructure manager. The result of the workshop was a filled out risk matrix for Slovenian Railways which shows the specific demand for wayside train monitoring on their network.

Risk is always defined as a product of probability and severity. For practical work with the term of risk a common understanding is necessary. Moreover a suitable layout has to be chosen. The European standard EN 50126 [3] offers the possibility to deal with different risks by usage of a risk matrix. The layout of a matrix provides the possibility to deal with different risks coming from different car related fault states in railway operation. The usage of the risk matrix in signalling issues is state-of-the-art. For the operational application the qualitative descriptions of probability and severity must be quantified. The calibrated matrix must cover the range of operational scope.

Weekly	0,48	0,2	0,05	0,0005
Monthly	0,12	0,05	0,01	0,0001
Quarterly	0,04	0,01	0,001	0,00001
Annually	0,01	0,001	0,0001	0,000001
Once in 10 years	0,0001	0,00001	0,000001	0,00000001
Once in 100 years	0,000001	0,00000001	0,000000001	0,0000000001
	10.000 €	100.000 €	1.000.000 €	10.000.000 €

Figure 1 Risk matrix for demand analysis for Slovenian Railways in Mio. €/a

### 3 Requirements

Due to the field of application, both sensor systems have to comply with several general requirements:

- Operating conditions: all outdoor parts of the system has to be designed for operation with an extended temperature range of -40 to +85°C and for dealing with further varying climatic conditions (humidity, dust, etc.).
- Power supply: the systems have to be able to operate with common power supply of Slovenia (230V/50Hz).
- Varying measurement objects: as mentioned in chapter 1, both sensor systems have to detect fault states reliable independent of vehicle type (freight and passenger cars) and of the direction of train drive.
- Maximum speed of the passing vehicles: the systems must not claim on braking to specific passing speed of the vehicles. Thus all trains have to be allowed to drive up to the specified track speeds (up to 250km/h on high speed tracks).

Minimum speed of passing vehicles: due to the need of recognizable peaks of dynamic forces for flat spot detection, axle load checkpoints require a minimum passing speed of 30km/h. In contrast, the measurement principle of hot box or hot brake detection allows temperature measurement even at very low speeds. But they need a minimum average speed before passing the measurement site for friction-based warming of defect bearings or of parts of the brake system. Without sufficient friction, defects systems won't be able to recognise these fault states. Thus, the requirement on the minimum passing speed of hot box and hot brake detection for measurement can be reduced to 5km/h, whereas the minimum average speed before measuring has to be significant higher (recommendation: normal driving speed of vehicles on the following track section).

#### 3.1 Hot Box Detector and Hot Wheel Detector

The measurement system has to monitor all kind of passing vehicles. As a consequence, the hot box detection has to deal with varying types of axle bearings. For correct interpretation of the bearing condition, the system has to provide a reliable temperature acquisition, regardless of the bearing type. The past has shown that due to their construction especially a temperature measurement of bearings on RoLa (intermodal transport) and on freight cars with the widely-used Y25 bogies or with 'Schlieren' type bogies are a challenge for several systems. The crucial factor to gain all-purpose hot box detection is the arrangement of the sensors in the measurement cross-section relative to the bearings. Thus, systems on the market vary in this point, whereas two general approaches can be identified [1]:

- Single-beam sensors (one sensor with one beam)
- Multi-beam sensors (one sensor with several beams)
- Multi sensor with single-beam (several sensors with single-beams)

The first and second category of hot box detection systems enable measuring only in radial direction from the installation position of the infrared sensor. The third category by contrast allows arranging the sensors on different positions and measuring with arbitrary angles. The only indication of an advantage of such an arrangement for detection of hot boxes on Y25 bogies may be concluded from a typical multibeam scanning configuration. Here, the multibeam is not able to detect the inner ranges of such a bearing construction, whereas dual beam systems with an appropriate sensors arrangement may have this ability. However, there is no serious information available about the reliability of these approaches for which reason verifiable experiences of such systems become more importance. Only the first category does not comply with the state of the art and can be excluded from these considerations.

In general, all brake components of an axle are controlled by an only one common valve. Due to the fact, that stuck brakes results almost always from defects of such control valves, the



temperature of both wheels or of all brake discs will raise similarly. Thus, for hot wheel and for hot brake disc detection only two infrared sensors are sufficient for reliable fault state recognition. The arrangement of sensors has to ensure the reliable temperature acquisition of different wheel diameters and different brake disc configurations. Moreover, sensor arrangements which imply measuring mat surfaces should be preferred, because metallic bright structures lead to low infrared radiation and thus to faulty temperature results.

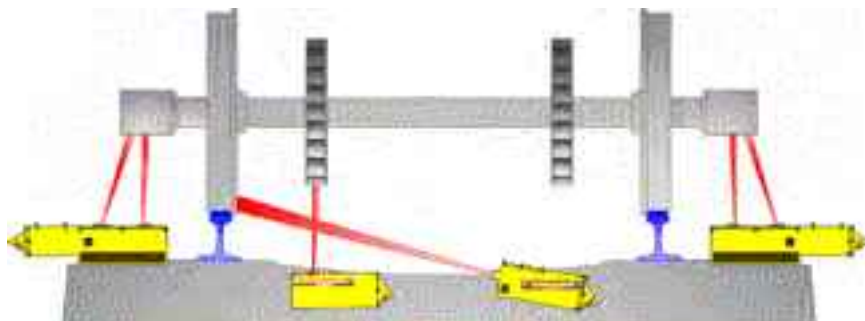

Figure 2 Measurement geometry of Hot Box Detector TK99 [5]

### 3.2 Weighting Systems with Flat Wheel Detection Function (Axle Load Checkpoints)

Axle load checkpoints measure forces, which are exerted by the vehicles wheels on the rails. In general, this contact-based measurements use either the bending characteristic of the rail between the sleepers or load cells between rails and sleepers to determine the wheel loads. Also a combination of these approaches is sometimes applied. Thereby following aspects have to be considered:

- Type of sensors: the sensors for acquisition of the elastic deformation (of the rail or of the weighing element within the load cells) have to be robust against the harsh environmental conditions (climate changes, electromagnetic fields, etc.). Because resistance strain gauges fulfil these requirements, they have prevailed in the field of wayside axle load measurements. Other systems also use laser technology for measuring the bending of rails, but the practical application was not satisfying customer requirements so far. For instance, in Switzerland SBB tested several axle load checkpoints from different suppliers. Finally they decided to build up their own system based upon strain gauges.
- Length of measurement section: for reliable detection of fault states regarding the running surface of wheels, always the whole wheel circumferences have to be examined. Thus, the measurement section has to cover at least one complete circumference of the largest diameter of the expected vehicle wheels (common wheel diameters are not larger as 1m, which yields minimum sections of approximately 3,2m). A further increase of the measurement section length often allows more extensive averaging of the measurement data, which may lower the influence of dynamic effects and which may reduce measurement errors of axle loads and of the running surface faults. Thus, many systems feature a section length of 8m and beyond.

## 4 Choice of Location

Wayside measures cannot be located at every place where once an accident occurred or will possibly happen. After an event has occurred, it is quite simple to design the optimal position for detection and minimising loss in this specific case. But this empirical method will not fulfil economic boundary conditions.

Generally there are two different points of view, the line-oriented and the network-oriented. The line-oriented view allows the calculation of the nearest position to have enough time for stopping a train at a predefined position for further investigation. For the specification of these points where the train has to stop the network-oriented view is helpful. So there is the requirement to define all risky elements in a railway network which should not be passed by a train with irregularities. Furthermore the combination of measures depends on the strategy of an infrastructure manager, which can be described as a mix of event-avoiding systems and damage-reducing components.

With regard to their future locations, there are two fundamental concepts:

- 1 Whenever traditional train supervision is to be replaced, a technical equivalent has to be installed.
- 2 The number of locations and/or systems necessary for conducting train supervision can be optimised provided that they are based on cost-benefit considerations. In this case, the number of locations should be lower.

Due to economic reasons only the second approach is practically relevant and will be discussed in the following section.

The process in case of a detected fault on a train has to be carefully planned before going into operation. For vehicle-side detection the data transmission to an operation control centre of an infrastructure manager has to be specified. Wayside systems are exclusively the responsibility of an infrastructure manager for the planning of locations until the operational handover.

Modern signal box technology enables the integration of the monitoring system. This allows an automatic stop of trains with strong irregularities, whereby the classification of these fault conditions must be done by the infrastructure manager (e.g. an already derailed axle on a train leads to a stop at the next mandatory signal). Basically it can be distinguished between warning and alarm: A warning indicates only an overstepping of threshold value that can lead to a dangerous situation (e. g. overweight of one vehicle, warm box). In case of an alarm there has to be an immediate reaction because of an already existing hazard (e. g. hot box, derailed axle). Thus, only highly reliable, available and accurate technical solution will be integrated into operations control because otherwise the reliability of operation would be reduced dramatically. The local position in the railway system is defined according to the last stopping position ahead of a risky element of infrastructure.

Taking the time behaviour of an integrated sensor system into account, the local position can be calculated in the following way: Starting from the mandatory signal (or stopping point) the nearest location of each sensor component can be found in consideration of the allowed speed limit, the sight on the distant signal and the response time of the sensor component.

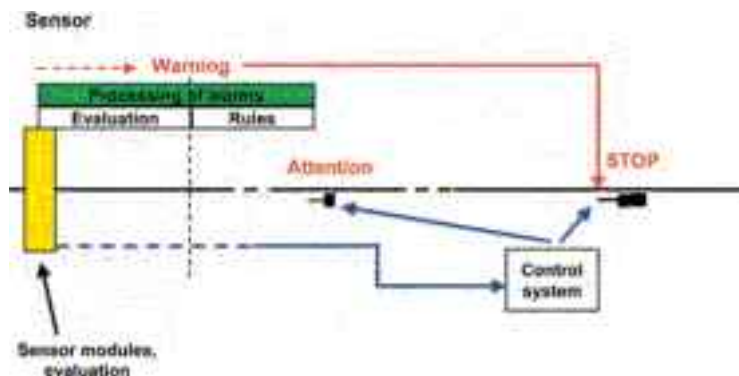

Figure 3 Calculation of position according to a predefined stopping point

The choice of location for wayside train monitoring is depending on the elements of infrastructure which are to be protected from hazard situations. Therefore it is necessary to define risky elements in a railway network. In accordance with the call for tenders only three categories of risky elements had to be identified in the network of Slovenian Railways:

- Gradient: a)  $> 15 \text{ ‰}$ ; b)  $10\text{--}15 \text{ ‰}$
- Tunnel (longer than 1 km)
- Network entry

## 5 Outlook

Finally this article shall give some recommendations for the next steps in the implementation of wayside train monitoring systems in the network of Slovenian Railways. Besides the price for purchase the life cycle costs (LCC) should be considered. Therefore the devices should allow a condition based maintenance. Moreover the availability of the devices should be high to achieve operational acceptance by station inspectors and drivers. Of course, the validation rate of alarms and warning must be close to 100 %. This requires also the development of an operational procedure with predefined responsibilities for the handling of alarms and warnings. For every alarm or warning the result of the inspection by the responsible staff must be documented for statistical reasons. Based upon previous experience a prototype installation of a hot box detection system and a dynamic weighting (inc. flat wheel indication) in the network of Slovenian Railways is suggested. After a successful trial period a tender should be prepared to cover all risky elements in the network by wayside train monitoring systems.

## References

- [1] Schöbel, A.: Wayside Train Monitoring Systems – an actual overview, RTR Special, ISBN 978-3-7771-0426-3, dvv Media Group, 2011.
- [2] Schöbel, A., Svalov, D.: Hazard Alert Systems, in: 'Railway Signalling & Interlocking', G. Theeg, S. Vlasenko (Hrg.); dvv Media Group GmbH | Eurailpress, Hamburg, 2009, ISBN: 978-3-7771-0394-5, S. 393 - 408.
- [3] European Committee for Electrotechnical Standardization. 'Railway Applications - The Specification and Demonstration of Reliability, Availability, Maintainability and Safety (RAMS)'. 1999.
- [4] Schöbel, A., Antov, A., Koller, R., Pisek, M.: Demand Analysis for Wayside Train Monitoring Systems for NRIC, keynote at UACEG 2009: Science & Practice, Sofia; 29.10.2009 - 31.10.2009; in: 'Proceedings', (2009), Paper-Nr. 5T1, 7 p.
- [5] Karner, J., Maly, T., Schöbel, A.: TK 99 - The Austrian Solution for Hot Box Detection, Zelkon o8, Nis; 09.10.2008 - 10.10.2008; in: 'Proceedings', D. Stamenkovic (Hrg.); (2008), ISBN: 978-86-80587-78-3; S. 57 - 60.

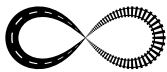

## THERMIC INTERACTION BETWEEN CONTINUOUS WELDED RAIL AND THE BRIDGE

Otto Plasek<sup>1</sup>, Vlastislav Salajka<sup>2</sup>, Michal Mrozek<sup>2</sup>, Milos Bratka<sup>2</sup>

*1 Brno University of Technology, Faculty of Civil Engineering, Institute of Railway Structures and Constructions, Czech Republic*

*2 Brno University of Technology, Faculty of Civil Engineering, Institute of Structural Mechanics, Czech Republic*

### Abstract

The Czech railway infrastructure manager has described design principles and recommendations for installation of continuous welded rail on bridges in a regulation which summarizes experience of bridge – rail interaction since the continuous welded rail was introduced as a common structure. The regulation covers the most common cases of bridge – rail interaction concerning the type of a bridge structure, deck and bearing arrangement as well as the design of rail superstructure components.

The bridge in Usti nad Orlici is situated on the main railway line Berlin – Prague – Brno – Vienna/Bratislava. Construction of the new bridge is a part of the railway station reconstruction project focused on speed increase. The design of bridge supports position had to take into account the situation of the confluence of two rivers and a road which led to designing a of nonstandard arrangement of the bridge bearings. This design required extra attention to an assessment of the particular bridge – rail interaction.

Two approaches to evaluation of the bridge – rail interaction were applied. The analytical solution consisted in solution of the system of differential equations describing the thermic interaction. Although the experience with the analytical solution is very good it doesn't included curvature of rail and the bridge as it was in this case. Therefore the finite element analysis was also performed in purpose to compare either results or estimate corrective factors or a modification of input parameters for the analytical method.

*Keywords: continuous welded rail, bridge rail interaction, bridge thermic expansion, track analysis*

### 1 Introduction

The thermic interaction bridge structure and continuous welded rail is a subject of investigation these days. Infrastructure managers would like to install continuous welded rail whenever track parameters permit it in the aim to significantly reduce the maintenance demands and costs. The only limiting parameter defined in the Czech regulation for the track outside bridges is value of curve radius 200 m when tracks are reconstructed or modernized. Installation of continuous welded rail according to the new draft of the Czech Infrastructure Administration regulation would be acceptable even in smaller radii for particular conditions. Needs to evaluate a number of cases of application of continuous welded rail on bridges in track sections, in which continuous welded rail was not possible to install previously, have arisen.

A clear and unambiguous method how to evaluate the interaction between bridge and rail is necessary for designers and infrastructure administration. It was found out that calculation

according to EN 1991-2 Eurocode 1 'Actions on structures', Part 2 'Traffic load on bridges' doesn't comply with the regulation of Railway Infrastructure Administration in the Czech Republic. It must be pointed out that the provisions of continuous welded rail installation on bridges are based on experience in long term behaviour of the interaction which is permitted to take into account according to the Eurocode.

The theoretical base of thermic interaction between bridge and rail will be described on the necessary level. The application of the theoretical base into calculations of permissible expansion length of bridges regarding effects in rail will be explained. The bridge in Usti nad Orlici which is situated on the main railway line Berlin – Prague – Brno – Vienna/Bratislava is an example of design of non-standard assembly of bridge expansion length and bearings. The differences in the interaction evaluation according these two different approaches are commented in the paper.

## 2 Theoretical description of the interaction between bridge and continuous welded rail

The application of continuous welded rail is based on the presumption that axial forces in a section of continuous welded rail, in which the whole track or rails don't move (more precisely  $(du/dx = 0)$ ), are proportional to thermic load and are independent on track length, which can be expressed, see for details [1]:

$$N_x = E \cdot A \cdot \left( \frac{du}{dx} - \alpha \cdot \Delta T \right) \quad (1)$$

in which  $N_x$  [kN] is axial force in continuous welded rail,  $E$  [Pa] is Young's modulus,  $A$  [m<sup>2</sup>] is area of rail cross section of both rails,  $u$  [m] is longitudinal displacement of track (rails or track length),  $\alpha$  [K<sup>-1</sup>] coefficient of thermic expansion of rail,  $\Delta T$  [K] temperature difference between actual and neutral temperature of rails.

Additional longitudinal load originates from accelerating or breaking forces of rolling stock. It was confirmed by calculations, practical experience and measuring that track is able to transfer and resist this load and as a structure it is safe and reliable.

The thermic expansion of bridge structure is another additional load causing on continuous welded rail. A basic question is how big expansion length is acceptable from point of view of the ability of track on the bridge to resist all longitudinal forces. When describing continuous welded rail on bridge we should assume the longitudinal displacement of track caused by the thermic expansion of bridge structure. An analogical situation of the track on subgrade in a cut or on an embankment is the breathing length of continuous welded rail where longitudinal displacements occur. They are not homogeneous ( $du/dx \neq 0$ ) and forces towards the rail end (rail joint or expansion joint) decrease. Mathematical description expresses the fact that changes of longitudinal forces along the track length is proportional to longitudinal resistance activated in a particular cross section and a load by acceleration or breaking of vehicles, which is expressed by a simple formula:

$$\frac{dN_x}{dx} = r_x - q_x \quad (2)$$

in which  $r_x$  [kN.m<sup>-1</sup>] is longitudinal resistance per meter,  $q_x$  [kN.m<sup>-1</sup>] is longitudinal load per meter caused by acceleration or breaking.

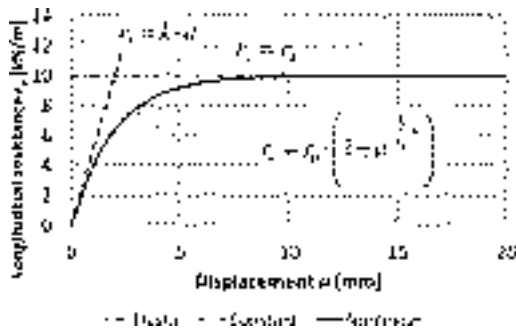

Figure 1 Longitudinal resistance of track as a function of displacement  $u$

The key parameter for the description of behaviour of continuous welded rail is longitudinal resistance of track either against subgrade or bridge structure. Longitudinal resistance is generally nonlinear function of longitudinal displacement of rail  $u$ , see Fig. 1. Calculation of longitudinal displacement  $u$  of continuous welded rail along the track length on subgrade is substantial for determination of axial forces  $N_x$  in continuous welded rail.

The longitudinal resistance of continuous welded rail on subgrade is often simplified as a constant value  $r_0$  which is independent on longitudinal displacement value. This approach can't be applied to track on bridge because the fact that forces transferred from bridge to rail would be constant and wouldn't be dependent on thermic expansion of bridge structure. That is why the conservative approach (on safe side) is usually introduced in which longitudinal resistance  $r_x$  is modelled by a linear function of longitudinal displacement  $u$ , for track on the bridge of relative displacement bridge – track:

a on subgrade 
$$r_x = k \cdot u \quad (3)$$

b on bridge 
$$r_x = k_b \cdot (u - u_b) \quad (4)$$

in which  $k$  [ $\text{kN} \cdot \text{m}^{-2}$ ] is constant expressing linear dependence on longitudinal displacement  $u$ ,  $k_b$  is constant expressing linear dependence on longitudinal relative displacement  $(u - u_b)$  [ $\text{kN} \cdot \text{m}^{-2}$ ].

Thermic expansion of bridge structure is described by  $u_b$  which can be calculated when omitting influence of rail on bridge because of much smaller cross section area of rails:

$$u_b = x_b \cdot \alpha_b \cdot \Delta T_b \quad (5)$$

in which  $u_b$  [m] is longitudinal displacement caused by thermic expansion,  $\alpha_b$  [ $\text{K}^{-1}$ ] is coefficient of thermic expansion of bridge structure,  $\Delta T_b$  [K] is temperature difference between actual temperature of bridge and bridge temperature at continuous welded rail installation,  $x_b$  [m] is distance from longitudinal rigid bridge bearings.

The complete solution was worked out and published by prof. Fryba in [2]. Behaviour of continuous welded rail on bridge can be described by differential equations evaluated as a combination of Eqs. (1) – (4):

a on subgrade 
$$-EA \frac{d^2 u}{dx^2} + k \cdot u = q_x \quad (6)$$

b on bridge 
$$-EA \frac{d^2 u}{dx^2} + k \cdot (u - u_b) = q_x \quad (7)$$

Differential Eqs. (6) and (7) are written for track sections in bridge vicinity and for every expansion structure of the bridge. Solution of these equations is both the longitudinal displacement

of rail on subgrade and on bridge and consequently the axial forces in track, solving of the equations is described in [2] or [3]. Function continuity is ensured by calculation of integration constants in the solution.

Input parameters are essential for the evaluation of the bridge track interaction. Prof. Fryba in [2] provides a comprehensive system of the input parameters, e.g. values of longitudinal track resistance in common conditions and separately in winter season, equivalent coefficient of thermic expansion  $\alpha_b$  for different kinds of bridge structures, calculation of critical forces and stresses in rails.

Equivalent coefficient of thermic expansion  $\alpha_b$  expresses the experience with bridge expansion which is usually less than calculated for  $\alpha_b$  related to a structural material and maximum and minimum temperatures. For example the coefficient  $\alpha_b$  equals  $6 \text{ kN}\cdot\text{m}^{-1}$  according to [2] for steel bridge structure with ballast bed, which is the bridge in Usti nad Orlici.

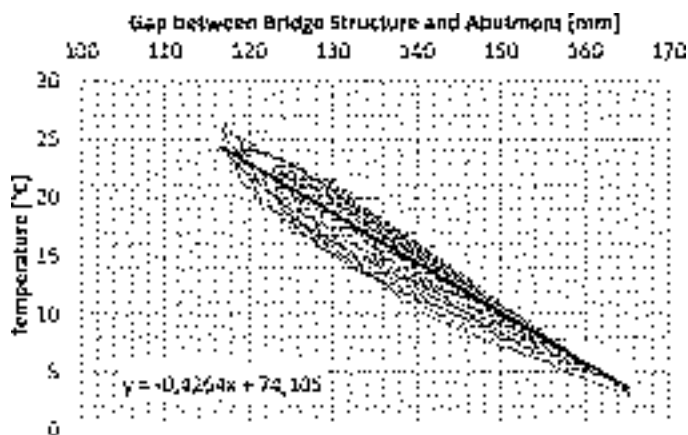

Figure 2 Thermic expansion of the bridge structure of Znojmo viaduct (slope coefficient is reciprocal to  $\alpha_b$ )

The coefficient  $\alpha_b$  was evaluated from recently finished continual monitoring of Znojmo viaduct (but there is not continuous welded rail), which is also a steel bridge with ballast bed. The coefficient  $\alpha_b$  was calculated by regression analysis for values of longitudinal expansion and temperature of the bridge structure stored every second during the two years monitoring. The review of analysis results is in the table 1 from which it is evident that the value of  $\alpha_b$  is bigger than  $6 \text{ kN}\cdot\text{m}^{-1}$ . The regression of values stored in April of 2011 is shown on Fig. 2. The value of coefficient marginally varies in particular months, see Fig 2.

Table 1 Results of regression analysis of thermic expansion of Znojmo viaduct

Length of the bridge [m]	Coefficient $\alpha_b$ [ $10^{-6}\text{K}^{-1}$ ]	Temperature range [K]	Calculated expansion [mm]	Measured expansion [mm]
220,97	9,7	51,4	110	111

### 3 Example of analysis of bridge – rail interaction

The solution of the bridge in Usti nad Orlici which is situated on the main railway line Berlin – Prague – Brno – Vienna/Bratislava is an example of analysis. The design of the position of bridge supports had to take into account the situation of the confluence of two rivers and a road which led to a design of nonstandard arrangement of the bridge bearings. The bridge – rail interaction was analysed both by analytical method and finite element method because of track in curve. The double track on the bridge is situated in the curve of radius 755 m. The ballast bed is designed continuously over the bridge. The viaduct is composed of three bridge structures separately expanded due to thermic loads. The main reason for the individual evaluation of the bridge structures and tracks on them was an untypical assembly of longitudinally movable bridge bearings of two structures opposite each other on the support and also the expansion length of structures over the limits according to the infrastructure administration regulation.

#### 3.1 Analytical solution

The analytical approach simplified the bridge structure as a system of interacting straight beams. The longitudinal resistance was substituted by a system of linear springs. The analytical calculations were based on the solving of the Eqs. (5), (6) and (7). The results of the solution were functions  $u$  and  $u_b$  which are used for calculation of axial forces in track  $N_x$  according to Eq. (1) and subsequently of stresses in rails  $\sigma_x$ . The values of displacements, forces and stresses were evaluated according to the Czech regulation by checking of following criteria:

- the forces in track caused by the maximum temperature must be lower than a half value of the critical force of track buckling;
- the additional stresses in rails originating from the bridge track interaction are included to the evaluation of rail stresses, rail wear is important;
- gap between ends of rail after accidental rail break must be less than 50 mm due to the minimum temperature load during the winter season; a vehicle could safely pass over a gap of this size;
- forces may not cause a damage of track components, especially rail fastening;

The analysis results of displacements of the bridge and rail in Usti nad Orlici are shown on Fig. 3, the results of axial forces are shown on Fig. 4. The comparison of results obtained by the analytical analysis and the analysis by Finite Element Method (FEM) are presented on both figures.

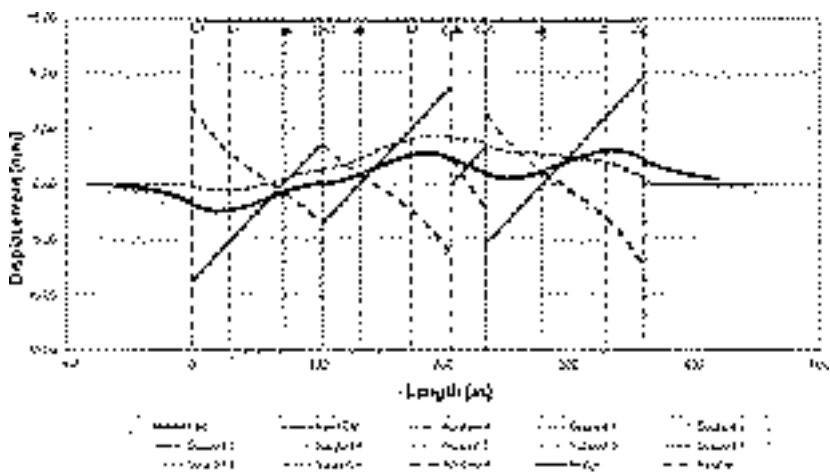

Figure 3 Longitudinal displacements for the maximum temperature



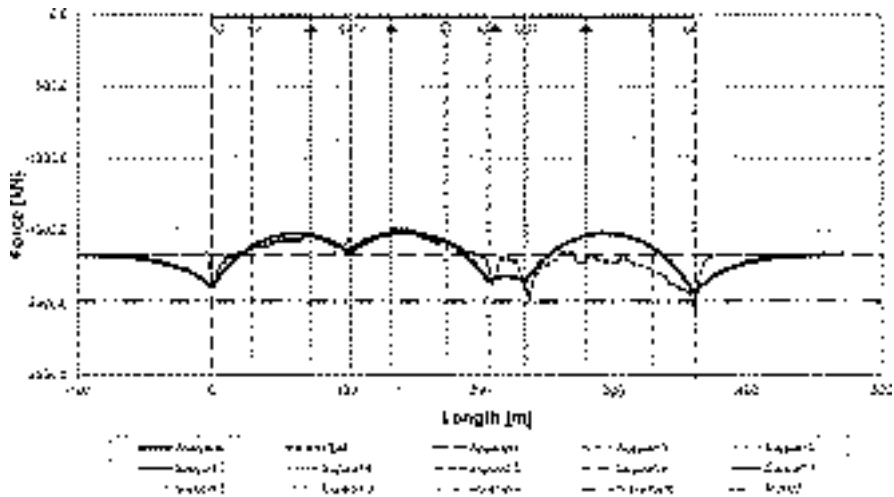

Figure 4 Axial forces for the maximum temperature

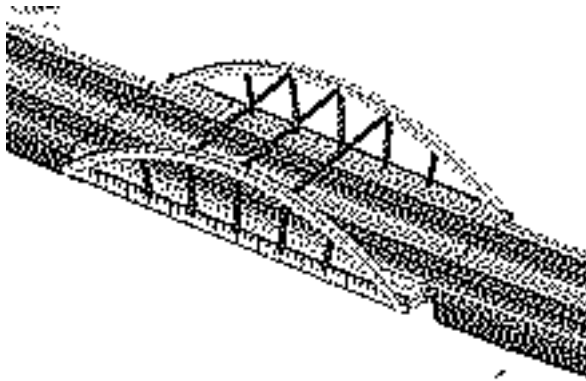

Figure 5 Detail of the middle part of the bridge in the FEM analysis

### 3.2 Finite element method analysis

The analytical methods of investigations of thermic interaction of bridge structure and continuous welded rail do not allow by a simple method taking into account a track in horizontal curve. That is why the FEM analysis, which permits to include this structure geometry, was done in parallel [4].

The horizontal geometry of the bridge structures was modelled, see Fig. 5. The longitudinal resistance was expressed by nonlinear contacts between ballast bed and the steel structure. On the other hand simplified boundary conditions at rigid bridge bearings and at the boundaries of the track model were included in the FEM model. Also model contended simplifications of subgrade and the bridge supports elasticity in longitudinal direction.

When comparing results of the presented analytical method and FEM it can be state a good correspondence between both results. An influence of horizontal curve is marginal concerning lateral parameters of the bridge structures Disturbances in FEM analysis are evident. These are caused by a particular interaction of track and ballast bed with components of the steel structure.

## Conclusion

Every bridge structure continuous welded rail is constructed on should be evaluated according to specifications of EN 1991-2 Eurocode 1 'Actions on structures', Part 2 'Traffic load on bridges'. This standard provides basic values of input parameters necessary for calculations of bridge rail interaction and analyses guidance. If the Eurocode parameters were used the evaluation of bridges would not be in compliance with experience of the Czech Railway Infrastructure Administration expressed in the regulations then. Besides the evaluation criteria are not the same in both standards which is confusing both for designers and administration. The only possibility how to solve these discrepancies between specifications in standards is use of calculation input parameters verified by years' experience and confirmed by monitoring. Currently a few projects focused on monitoring of temperature loads, expansion of bridge structures and consequently behaviour of continuous welded rail are in process in the Czech Republic.

On the other hand it is evident from the comparison of interaction calculations that an analysis method doesn't play an essential role neither in case of the bridge in a curve nor in modelling of longitudinal resistance as linear or nonlinear.

## Acknowledgment

This outcome has been achieved with the financial support of the Ministry of Education, Youth and Sports of the Czech Republic, MS12701918 Progressive reliable and durable structures.

## References

- [1] Plášek, O., Zvěřina, P., Svoboda, R., Mockovčiak, M.: *Železniční stavby. Železniční spodek a svršek (Railway Structures. Railway superstructure and Substructure)*. 1. vyd., Brno: CERM, 2004. 291 str. ISBN 80-214-2621-7.
- [2] Frýba, L.: *Dynamika železničních mostů (Dynamic of Railway Bridges)*. 1.vyd., Academia, Praha 1992. 328 str. ISBN 80-200-0262-6.
- [3] Esveld, C., *Modern Railway Track*. Second Edition. Delft, MRT – Production, 2001, 2nd ed. 654 p. ISBN 90-800324-3-3.
- [4] Mrózek, M.; Bračka, M.; Plášek, O.; Salajka, V., *Analysis of Continuous Welded Rail at Railway Bridge, příspěvek na konferenci Engineering Mechanics 2009, Svatka, Česká republika, 2009, ISBN 978-80-86246-35-2.*



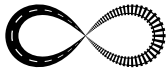

## EXPERIENCES FROM BRIDGE SCOUR INSPECTIONS BY USING TWO ASSESSMENT METHODS ON 100 RAILWAY BRIDGES

Damir Bekić<sup>1</sup>, Eamon McKeogh<sup>2</sup>, Igor Kerin<sup>1</sup>, Stephen Hand<sup>2</sup>, Gillian Bruton<sup>2</sup>

*1 University of Zagreb, Faculty of Civil Engineering, Croatia*

*2 University College Cork, Department of Civil & Environmental Engineering, Ireland*

### Abstract

This paper presents results of bridge scour risk assessment by using two qualitative methods. The first O'Connor Sutton Cronin method is based on a sum of parameters derived from flow charts taken from the Colorado method. The parameters describe general scour vulnerability, left and right abutments and the worst pier conditions, which are all evaluated by relative points. The output of the ocs method is Vulnerability Ranking Score (VRS), based on which a Priority Rank for all bridges on a single railway line is given. The second Bekić–McKeogh method was developed for Irish Rail on the basis of various standards and policies for scour evaluation. The output from the Bekić–McKeogh method is a Priority Rating (PR), accompanied with the recommendations and a period for the next bridge inspection. Comparison of assessment results by using two methods are presented for 100 railway bridges over the rivers and streams in Ireland. The paper in particular shows different assessment results obtained for three bridges, where results of both methods are compared and analysed in detail.

*Keywords: bridge scour, bridge inspection, scour risk assessment*

### 1 Introduction

Bridge scour usually develops during flood flows. If a scour hole becomes relatively deep and close to the footings of a pier or abutment, it threatens the bridge stability. The further development of a scour hole could subsequently cause a partial or complete bridge collapse. Wardhana and Hadipriono [1, 15] analysed the causes of collapse on over 500 bridges in the USA from 1989–2000. Their study implies that scour is the most common cause of bridge collapse in the USA. Eighty three percent of all bridges collapse due to natural causes (earthquake, flooding, fire, ice, hurricane or other catastrophic factors), and bridge scour associated with flooding was the cause at 53% of bridges that collapsed due to natural causes.

This paper presents the results of bridge scour assessment for railway bridges in Ireland by using the two assessment methods. The first method is ocs method which has been developed on the basis of Colorado method [2]. The second Bekić–McKeogh is a new method which is based on various us and uk standards and guidelines. Both methods are qualitative and use a combination of visual field appraisals and desk studies. The bridge scour risk was evaluated by two methods on 100 railway bridges by using the same input data and readily available information including previous desk studies, bridge construction records, historic mapping and flood records. As the standard procedure for scour risk assessment in Ireland was not available, two methods were developed to assist the national rail company, Irish Rail, in directing resources in an efficient way.

## 2 Description of methods

In the USA, three documents on bridge scour risk are available, HEC-18, HEC-20 and HEC-23 [11, 12, 13], as well as the Technical Advisory section [14]. These three HEC documents were developed for the Federal Highway Administration and serve as the base for the Departments of Transportation to develop their own programs for bridge scour analysis. The us Dept of Agriculture, Forest Service developed its own programme for the assessment of bridge scour risk [10].

In the UK, two standards for bridge scour analysis have been used. The first Railtrack method was developed in 1989 for British Rail and was published in 1993 as Handbook No 47 [5]. The second method was developed by the UK Highway Agency and was published in 2006 as Design Manual for Roads and Bridges – BA 74/06 [9].

### 2.1 OSCS method

The main steps in the O'Connor Sutton Cronin (OSCS) method [8] include office screening, bridge inspection, recommendations, bridge ranking and prioritization. With the exception of vulnerability ranking and subsequent prioritisation, the general OSCS approach is in accordance with the CIRIA [3] and HEC-18 [11] documents. The vulnerability ranking approach is in accordance with the procedure given in the USDA Forest Service [10].

Vulnerability of each bridge component (watercourse, abutment, pier, etc) is evaluated by a separate flow chart and is presented by points (see Figure 1). Vulnerability of each bridge component (number of points) is a sum of all parameter on a flow chart, and more points presents higher vulnerability. Each bridge component has different maximum number of points, as follows:

- 1 General vulnerability (maximum 23 pts)
- 2 Left abutment (maximum 14 pts)
- 3 Right abutment (maximum 14 pts)
- 4 The worst pier (maximum 15 pts)

The overall vulnerability of a bridge is then obtained as a sum of points for each bridge component. The overall vulnerability is termed Vulnerability Ranking Score (VRS), and the highest score is 66 points.

After obtaining VRS for all bridges, the scour risk for each bridge is presented through Priority Ranking, such as Low, Medium or High Priority (Error! Reference source not found.). The purpose of the assigned VRS is to provide an indicative comparison between bridges, so the absolute value of VRS has no physical meaning for a single bridge.

**Table 1** OSCS Priority Ranking and Vulnerability Ranking Score (VRS)

Vulnerability Ranking Score (VRS)	Priority Ranking
≤30	Low Priority
31–39	Medium Priority
≥40	High Priority

## 2.2 Bekić–McKeogh method

The partial collapse of the Malahide Viaduct on the 21<sup>st</sup> August 2009 occurred due to weir scour and the undermining of one of the eleven bridge piers [6, 7]. Only three days prior to the collapse a bridge inspection was carried out. The Malahide Viaduct collapse showed that the existing bridge inspection method was inappropriate as it do not consider broader hydrological and hydraulic inputs.

The Bekić–McKeogh method was developed as a standard methodology for bridge scour inspections and subsequent actions for Irish Rail. The method uses a staged approach of scour risk assessment, based on various standards: CIRIA [3], BA 74/06 [9], USDA Forest Service [10], HEC18 [11] and other relevant documents, and involves three stages of risk assessment: Stage 1 Assessment, Stage 2 Analysis and Stage 3 Strategy.

The principal element of Stage 1 is an assessment by the Inspector as to whether the bridge could suffer from scour damage at all, and to identify those bridges where the risks are significant and remedial action needs to be taken. The main deliverables of Stage 1 are Priority Rating of the bridge scour potential and recommendations (see Table 2).

**Table 2** Bekić–McKeogh method – Priority Rating and bridge scour risk

Bridge scour risk	Priority Rating (PR)
Insignificant risk	1
Low risk (maintenance, minor actions)	2
Move to Stage 2	3
Immediate action required (PoA)	4

Priority Rating 1 – Insignificant risk implies that scour risk is minimal and the next bridge inspection is recommended after 6 years. Priority Rating 2 – Low risk follows a special recommendation for the next bridge inspection which is within range from 1 to 5 years. Follow-up steps for the bridges which have been ranked with ratings 3 and 4, respective to table above are Move to Stage 2 or Immediate action required (Plan of Action).

For an estimate of scour vulnerability for each bridge element, the ocsc method uses flow charts from the Colorado method [2]. The overall bridge scour vulnerability (Total Vulnerability Score) is a simple sum of points of all bridge elements (according to USDA Forest Service [10]). The Bekić–McKeogh method uses a qualitative assessment of scour potential. The vulnerability to global and constriction scour are analysed separately, and global and constriction scour potentials are evaluated after an analysis of the extreme fluvial and, if relevant, tidal flows. Total bridge scour risk is assessed on the basis of potential of each type of scour and their estimated impact on bridge stability, and is presented as Priority Rating accompanied with the period for the next bridge inspection. Table 3 shows an overview and outputs of the ocsc and the Bekić–McKeogh methods.

## 3 Statistics of assessment results

From a total of 100 inspected bridge structures there were, 6 culverts, 17 simple bridges and 77 complex bridges. Foundation details were unknown for 79 bridges. Out of 6 culverts, foundations were known for 4 culverts. Also, out of 17 simple bridges, only 1 bridge had known foundations. Out of 77 complex bridges, 16 bridges had known foundations and 61 bridges had unknown foundations.

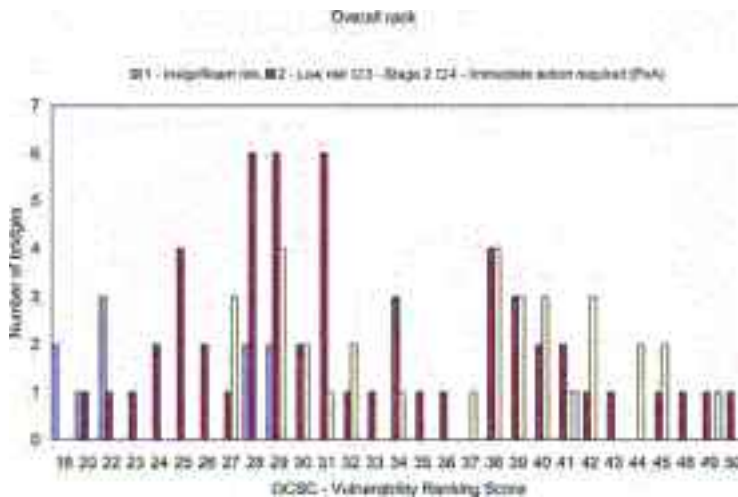

Figure 1 A comparison of scour risk assessment between Bekić-McKeogh and OCSC method

A comparison of assessment results of the two methods for all bridges is presented graphically (Figure 5). Horizontal axis shows the ocsc Vulnerability Ranking Score (vrs). Vertical axis shows number of bridges separately for each Priority rating (PR) from the Bekić-McKeogh method. For an illustration of comparison one reads that out of 4 bridges with Vulnerability Ranking Score of 22, 3 bridges were rated as Insignificant risk and 1 bridge as Low risk. Similar assessment of bridge scour risk by two methods would show that bridges with vrs less than 30 (Low Priority) should be rated as Insignificant risk or Low risk only. Analogous would be for the bridges with vrs over 40 (High Priority) which should be rated only as Move to Stage 2 or Immediate action required if method would be similar. However, a comparison of results for 100 bridges implies that two methods gained different results in a significant number of cases. The assessment of scour risk deviates for 19 bridges, where 10 bridges rated as Low risk by Bekić-McKeogh have High Priority raking by OCSC. But the real issue of concern are 9 bridges rated as Move to Stage 2 by Bekić-McKeogh that have Low Priority raking by OCSC.

## 4 Examples of different scour risk assessments

It is useful and informative to analyse the factors which influence the final score (vrs and PR). Analysis was conducted based on the individual bridge examples. The vrs and PR values for 3 bridges were analysed. Besides the vrs and PR, for every bridge analysed the circumstances which led to the final score were explained. Finally a review of the ocscs and Bekić-McKeogh methods was made based on the type of factors that mostly influenced the final rating (vrs and PR) for each bridge.

### 4.1 UB65 Dublin/Belfast line (Delvin River)

The UB65 bridge (UB65 is the Irish Rail bridge identification number) is a Complex bridge with three open spans. Steel bridge piers are founded deeply in the bed of the river and they are probably founded on rock. The left bridge abutment is set away from the river channel on a higher level. The right abutment is set at the river channel. Extensive coastal erosion processes are evident around the bridge and the coastline has shifted landwards significantly. Further progressive erosion could undermine the right embankment toe from the sea and, combined with the potential inside erosion of the embankment slope, it gives the highest risk to the stability of the railway embankment.



**Figure 2** Aerial view of UB65 bridge, looking upstream

The VRS of 29 implies Low Priority of scour risk by the OCSC method. The general vulnerability counted 9 points (of maximum 23), both abutments counted 16 points (8 points per each abutment) and the worst pier counted 4 points. The Bekić–McKeogh method rated the UB65 bridge as Move to Stage 2, as the bridge is located on tidal part of the river, and due to the evident coastal erosion which threatens the railway embankment and bridge stability. This example shows that the assessment by the OCSC method cannot account the impact of coastal erosion to the scour risk, which in the case of UB65 bridge threatens the stability of railway embankment and the right abutment.

#### 4.2 UB207 Dublin/Wexford line (Avoca River)

UB207 is a single span steel girder bridge on masonry abutments construction in circa 1865. The deck width is 6m and the bridge width is 29.7m. The bridge is classified as a 'complex bridge'. There is no information available regarding any modifications since its original construction and the foundations are unknown. There is evident erosion on the upstream river bank. Scour protection around the both abutments appears to have deteriorated. Further progress of bank erosion towards the bridge would threaten the stability of the left abutment and the bridge.

The VRS of 29 by the OCSC method implies Low Priority of scour risk. General vulnerability counted 12 points (of maximum 23), and both abutments counted 17 points. The Bekić–McKeogh method rated the bridge as Move to Stage 2 as the the bridge is located on an unstable river section. The river channel was rated unstable both upstream and downstream (Rank 4). The constriction scour potential was rated high (Rank 4).



**Figure 3** Upstream river channel at UB207 bridge, looking downstream



The UB207 bridge example implies that the vrs by OCSC method is too low. The method gives too low score for the general and constriction scour potential, which is nearly the same score as for the generally stable channel. This case shows that the OCSC method for assessment of scour risk cannot properly account the risk of bank erosion to the bridge stability.

### 4.3 UB18 Mallow/Tralee line (River Glen)

The bridge UB18 is 3-span masonry arch bridge. It was constructed circa 1889 and is classified as a 'complex bridge'. The foundations are unknown. The width of the river channel at the bridge is approximately 17m. The bridge has two stone masonry piers, 6.15m long and 1.25m wide with sharp edged noses.

The bridge has a history of scour as shown by the presence of scour protection measures on the river bed and banks. Although general lateral movement of the river channel is not evident, there is high potential for vertical channel instability. A significant water level dropdown and at least 1.0m deep scour hole in the river bed are evident under Span 2. A scour hole in the river channel is a threat to the stability of Pier 1 and Pier 2. Heavy sedimentation downstream of Pier 2 and a dropdown of the river bed below the bridge confirms morphological activity.



Figure 4 Aerial view of UB18 bridge, looking upstream.

The vrs of 30 points implies Low Priority of scour risk by the OCSC method. The general scour vulnerability counted 13 points (out of 23 maximum), both abutments counted 7 points and the worst pier counted 10 points. The Bekić–McKeogh method rated the bridge as Move to Stage 2 as there are several local and global scour risk issues. The river channel was rated as unstable both upstream and downstream of the bridge (Rank 4). The UB18 bridge example also shows that the OCSC method underestimates the scour risk and does not account properly the bridge scour potential.

## 5 Conclusions

As a standard procedure for scour risk assessment in Ireland is not currently available, two methods were developed to assist Irish Rail in managing the bridge scour risk in an efficient way. The OCSC method has been developed on the basis of Colorado method [2], and the Bekić–McKeogh method is based on various US and UK standards and guidelines. The bridge scour risk was evaluated on 100 railway bridges over water in Ireland by using the same input data and readily available information including previous desk studies, bridge construction records, historic mapping and flood records. A comparison of results by two methods showed that assessments deviate for 19 bridges. The 10 bridges rated as Low risk by Bekić–McKeogh have High Priority raking by OCSC. The real issue are 9 bridges that have Low Priority raking

by ocsc which are rated as Move to Stage 2 by Bekić–McKeogh. According to the obtained results and presented examples it can be concluded that the methods which use the Colorado flow charts and Vulnerability Ranking Score [2] are unreliable for evaluation of bridge scour risk on complex terrain and should be carefully utilized in rapid assessments of bridge scour.

## References

- [1] A. Melih Yanmaz; Alp Caner; Aysu Berk, Renovation of a Safety-Inspection Methodology for River Bridges, *Journal of Performance of Constructed Facilities*, Vol. 21, No. 5, pp. 382-389, DOI: 10.1061/(ASCE)0887-3828(2007)21:5(382), 2007.
- [2] Colorado Bridge Safety Assurance, Procedure for Colorado Highway Department, Ref. 1514, April 1990.
- [3] Construction Industry Research and Information Association (CIRIA), *Manual on Scour at Bridges and Other Hydraulic Structures*, C551, London, 2002.
- [4] Govindasamy, A., *Dissertation: Simplified Method for Estimating Future Scour Depth at Existing Bridges*, May 2009.
- [5] HR Wallingford, *The Railtrack Procedure*, 1993.
- [6] McKeogh, Dr. E. and Bekic, Dr. D., *Malahide Viaduct Reinstatement, Technical Paper 1, Collapse Mechanism and Initial Emergency Works*, Flood Study Group University College Cork, 2010.
- [7] Railway Accident Investigation Unit, *Malahide Viaduct Collapse on the Dublin to Belfast Line on the 21st August 2009, Investigation Report No. 2010 – Ro04*, 2009.
- [8] O'Connor Sutton Cronin & Associates, *Railway Bridge Scour Management Project, Ref1127, 2009/2010*.
- [9] The Highways Agency, *Assessment Of Scour At Highway Bridges, Design Manual For Roads And Bridges, BA 74/06*, 2006.
- [10] U.S. Department of Agriculture - Forest Service, *Bridge Scour Evaluation: Screening, Analysis & Countermeasures*, r 1998.
- [11] U.S. Department of Transportation - Federal Highway Administration, *Evaluating Scour At Bridges, Fourth Edition, Hydraulic Engineering Circular No. 18*, 2001.
- [12] U.S. Department of Transportation - Federal Highway Administration, *Stream Stability at Highway Structures, Third Edition, Hydraulic Engineering Circular No. 20*, 2001.
- [13] U.S. Department of Transportation - Federal Highway Administration, *Bridge Scour and Stream Instability Countermeasures: Experience, Selection, and Design Guidance-Third Edition, Hydraulic Engineering Circular No. 23*, September 2009.
- [14] U.S. Department of Transportation, Federal Highway Administration, *Scour at Bridges, Technical Advisory T5140.20*, 1988.
- [15] Wardhana, K.; Hadipriono, F. C., Analysis of Recent Bridge Failures in the United States, *Journal of Performance of Constructed Facilities*, Volume 17, Issue 3, DOI: 10.1061/(ASCE)0887-3828(2003)17:3(144), 2002.



## 9 RAIL INFRASTRUCTURE PLANNING



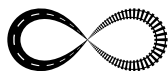

## THE IMPORTANCE OF INDUSTRIAL TRACK IN RAILWAY INFRASTRUCTURE

Waldemar Alduk<sup>1</sup>, Sanja Dimter<sup>2</sup>, Zlata Dolaček–Alduk<sup>2</sup>

<sup>1</sup> HŽ Infrastruktura d.o.o. Zagreb, Croatia

<sup>2</sup> Faculty of Civil Engineering Osijek, Croatia

### Abstract

An important part of the railway infrastructure in the area of freight transport designed to simplify the transportation process and benefit the economy of an area are industrial tracks. Industrial tracks provide different benefits to users and railways. Enable customers to deliver the goods in the factory, avoiding the cost of loading and a lower total cost of transportation, a rail unloading station, reducing the work operations at railway stations, increasing passenger safety and reduce traffic congestion near the station. While in the economically developed countries the number of industrial tracks and their utilization is significant, in less developed countries the number of industrial track is a bit smaller. According to data from 2009 at the Croatian railway network, there were 314 primary industrial tracks, although only 168 of them in greater or lesser extent perform manipulative actions. The remaining 146 of the track has been temporarily closed and inactive. Closure and abandonment of some industrial tracks is caused by the changes in the economy and the real needs of users. Although the existing industrial intersections generates about 70% of total freight transport, are noticeable problems with the technical condition of the track, an organization working on them and the relationship of railroads and industrial users of the track. Retention and renewal of existing and construction of new industrial track, it would be possible to increase the competitiveness of rail compared to other modes of transport.

This paper describes the characteristics of the industrial tracks with special emphasis on the construction of an industrial track for the cement factory Našicecement in Našice. Construction of the track allowed the multiple benefits: shorter transport time and energy saving, rational use of means of transport and labor, reducing transport costs, increase traffic safety and reliability of the transport system and increasing the competitiveness of factories in the market.

*Keywords: industrial tracks, rail freight, users, benefits*

### 1 Introduction

An important part of the railway infrastructure in the area of freight transport is industrial tracks, designed to simplify the transportation process and benefit the economy of an area. The main purpose of these tracks is to connect the nearest railway stations with a large manufacturing and industrial plants, mines, ports and harbors, and thus allow easy delivery of massive goods (mainly iron, coal, wood). In recent times, due to the reduction or termination of mass industrial goods, industrial tracks serving other industries such as commercial companies, storages and transshipment terminals.

Industrial tracks are special railway tracks whose length of main siding track can be from several hundred meters to few kilometers, at the end of which one track can branched into

several. In accordance with the Law Railway Safety [1] industrial track is defined as a railway track that is not a public property and not in public use, connected to the railway line, used for entering and leaving goods on rail vehicles for the owner of that track and used by the industrial railway for transport for their own use. Regulation of conditions for safe railway traffic [2] defines industrial tracks as an industrial railroad track that connects in the railway station or on the open railway section and is used by holder of the rights of use.

Industrial tracks provide different benefits to users and railways: allow users to deliver the goods in the factory, avoiding the cost of loading and a lower total cost of transport. For railway, reducing overloading and working operations of railway stations, increase passenger safety and reduce traffic congestion near the station. By its technical characteristics, industrial tracks are often not at the level of railway traffic intended for the public traffic. At the industrial track valid are business regulations agreed between the rail and users [3].

Although the industrial tracks should be used at the beginning and the end of the transport process, so they should allow continuity of traffic, they often exploit only one of the cargo operations (loading or unloading of goods from the wagons). Such limitation of industrial track usability could be avoided by expanding and modernizing the network of tracks wherever possible.

## 2 The importance of industrial tracks

The importance of industrial tracks is primarily the simplification of the transport process. By joining the factory industrial tracks preclude the need for the participation of motor vehicles operations, provide transportation service 'door to door' thereby increasing the competitiveness of rail transport. Benefits for users are numerous: the direct delivery of goods is less time consuming because of machinery use and less handling (especially important for loose load), less costs or damage of goods since reloading is not needed using only railways, enabled saving on the cost of loading or unloading using their own machinery and ultimately lower overall transportation costs. Benefits for the railway are: direct trains are using industrial tracks because the need to transport large quantities of goods, minimizing congestion at the station manipulative tracks, short time for wagons handling, direct linking of internal and international railway transport and creating a habit of using rail transport links with permanent large users [4].

Developed European countries have well-developed industrial railway infrastructure. Besides the desire for greater security, long-term transportation and safe delivery, the development was accelerated by the fact of a price increase of truck transport in Europe due to increasing fuel prices and tolls as well as the European directive on limited working time for truck drivers. A large number of European companies owns and extensively uses industrial tracks. Some of them, like Germany's BASF chemical producer, even built their own industrial railway station and many tracks with smaller container terminal, all as effort of building a complete delivery network and achieve the best transport efficiency [5].

The situation in the economically less developed countries is quite different: a much smaller number of the industrial tracks most of which are in poor condition due to inadequate maintenance. This was due to many factors, particularly bad development of economic areas and poor planning of transport infrastructure. Unfortunately, existing state of industrial tracks in Croatia cannot be called satisfactory.

## 3 Condition of industrial tracks in Croatia

Analysis of the distribution of industrial tracks in total extent of loading and unloading of goods shows a very large share of industrial tracks, even up to 85%. This is evidence of their importance for rail freight transportation in Croatia.

According to data from 2009 [4], Croatian railway network recorded 314 primary industrial tracks, although only 168 of them in greater or lesser extent perform manipulative actions. The remaining 146 track is temporarily closed and inactive. Closure or abandonment of certain industrial tracks is caused by the changes in the economy and the real needs of users. Industrial tracks are privately owned by various companies, mainly for large customers in the area of sea and river ports, oil companies, cargo terminals and companies involved in manufacturing, where exists a need for mass transportation of goods.

Problems related to the operation of industrial tracks are primarily related to the technical condition, construction and maintenance, then the organization of work on industrial track, the relationship between railroads and the owners of industrial tracks and abandoned industrial tracks.

The technical condition of most industrial tracks is not very well. Most of all tracks in Croatia were built 30 years ago; permissible axle load on them is small and prevents the maximum utilization of wagon loading capacity increasing their required number. Only 15–20 industrial tracks of large customers is in good technical condition: average static loading wagon is 42 tones per wagon which is substantially greater than 31 t load rail station tracks.

Maintenance of industrial tracks is done at low level, in order to maintain minimum operating conditions. Such a restrictive maintenance has effect of lower projected levels of elements, the exploitation of tracks that should be nearly closed and frequent extraordinary events such as slippage of wagons, which creates additional damage. Most industrial tracks require reconstruction, repair and enhanced maintenance. During reconstruction of the superstructure and subsoil, also on existing buildings on the track route, reconstruction costs are substantially increasing.

Often happens that work organization of the industrial tracks and their confrontation to rail station tracks that technological processes are not aligned. On many industrial tracks outdated equipment is used. Further, the relationship between railways and users (or owners of industrial tracks) is not on sufficient level what threatens the possibility of further cooperation. The problem is evident in the absence of a clear strategy for development of industrial tracks. From 15 free zones in Croatia, 10 of them located maximum one kilometer from the railway infrastructure but only three industrial zones have internal tracks. From 112 enterprise zones only 65 are using railway infrastructure as part of its transport links.

Based on the analysis of the actual situation of industrial tracks 'Alliance for the railways' in 2010 started with project about revitalization of industrial tracks [6], primarily in free and entrepreneurial zones. The project objective was to encourage legal changes and to define concrete measures in the construction of railway infrastructure. For this purpose, project proposed five different models of new approaches to construction and renovation of industrial tracks [5] which may act individually or collectively. Common to all models is giving incentives to local and state authorities in the construction and reconstruction of the track. This would increase the share transfer on industrial tracks, also increased the share of rail transport in total transport, which would result in significant savings in the maintenance of transport infrastructure and reducing environmentally harmful effects of exhaust gases and noise.

The remainder of this paper will describe the construction of an industrial track for the purposes of cement factory Našicecement in Našice, town in east part of Croatia.

#### **4 New industrial track for the cement factory Našicecement in Našice**

Cement factory Našicecement (Fig.1.), which operates under the 'Nexe group' is the most modern and the only cement factory in continental Croatia. Production of over one million tons of cement per year required the supply and shipment of large load quantities, which resulted with building of special, industrial track for the factory. According to the factory plans, annual production volume of over one million tons of cement and clinker, need more than 500.000t load (gypsum, slag, fly ash, coal, cement, clinker) transported by railway [7].





**Figure 1** Cement factory Našicecement [7]

According to the Rules of the technical requirements for the rail traffic safety [9] 'special track attached to the open railway section' is a railway track which is a public property in general use, connected to the railway line and used for entering and leaving goods by railway vehicles for transport users. Special track for cement factory was constructed in two sections (Fig.2). The first section is a special track attached to the open railway section; investor is HŽ Infrastruktura d.o.o Zagreb (HŽ Infrastructure Limited Liability Company for Management, Maintenance and Building of Railway Infrastructure). A special track starts at the beginning of the disconnector switch in km 4+999.87 on railway line Našice L206-Nova Kapela/Batrina, and ends in km 3+645.63 on the last switch of transceiver group.

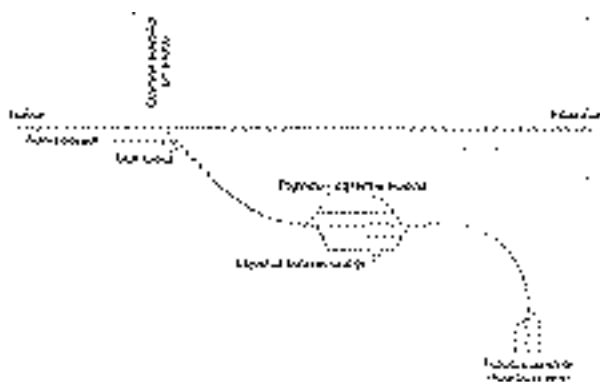

**Figure 2** Schematic review of a section of special track [7]

The second section is an industrial track in which is investor company Našicecement. The section starts from the end of a special track at km 3 +645.63 and ends at km 4 +512.068 where are loading–unloading groups of tracks in the production plant factory Našicecement. Before the start of construction work on a special track, the route along the length of 4.8 km from the rail station Našice to the branch switch is reinforced and bearing capacity is increased on the category C<sub>4</sub> (20 t/a, 8 t/m<sup>2</sup>). That was necessary because of poor condition and reduced bearing capacity in open railway section L206 Našice–Nova Kapela /Batrina. Special track Našicecement is separate with switch in km 4+999.87 from the railway line L206 Našice Nova Kapela/Batrina (km 0 +000 special track), and is designed for speed  $V_{max} = 50$  km/h and maximum permissible load categories D<sub>4</sub> (load 22.5 t/a and 8 t/m<sup>2</sup>).

In km 0+073 of special track, a protective switch was built in with protective track to prevent uncontrolled release of trains from special track on open railway track. From the protective switch track route is made by circular arcs  $R_1=300\text{m}$  i  $R_2=400\text{m}$  which are connected with lines of different lengths. Vertical alignment of track is in continuous longitudinal grade of -7 ‰. The route of the track is laid on the hilly, forested terrain, unfavorable geologic and geotechnical characteristics with very low bearing capacity and high instability.

On the route are many cuts and embankments, some higher than 12 or 15m. Due to the height of cuttings and geotechnical characteristics of the terrain contractors have met with a number of unforeseen works specifically on the stabilization of slopes, which is significantly slowed the dynamic of works.

There are four reinforced concrete bridges along the route, three bridges have a span of 6m for forest roads needs, and one has a span of 8.4 m for a local road. Also, there are 13 pipe culverts with diameters 100 and 200 cm; some are longer than 48 m.

On the plateau transceiver group from km 3+064 to km 3+645.634 five rail stations tracks are built with a usage length of 420 to 480m, accommodation facilities for staff and an access road and parking for cars, vans and heavy goods vehicles.

From the rail station Našice to transceiver group a safety signaling and telecommunications infrastructure was built, what enables remote setup times and run branch of the disconnecter and protective switches from rail station Našice (Fig. 3).

Special track is designed for load category D4 (permissible vehicle load 22.5 t/a, and 8 t/m'), with rail type 49E1 on concrete sleepers of type PB85K-49, on formation level track width 6.5m, sub base thickness 20 cm and crushed curtains (Fig. 4).

Preliminary work on the special track realization began in September 2006. Realization of construction works of special track started in August 2008, and completion of work ended in December 2011. In this moment the activity taking place on procuration of operating licence. Total value of financial resources that are invested by the HŽ Infrastruktura Zagreb, which includes the extension of track formation and repair from the rail station Našice to km 5+000 on railway line L206 Našice–Nova Kapela/Batrina and construction of special track from km 0+000 to km 3+645 is estimated at around 130 million HRK (equal to 17, 3 million EUR).



Figure 3 Disconnector switch on special track



**Figure 4** Special track of cement factory Našicecement

In parallel with the construction of a special track (investor is HŽ Infrastruktura Zagreb), Našicecement is built an industrial track on the second section, where the works are also completed. This section presents for Našicecement first phase of construction, which was aimed to ensure the necessary conditions for transport of the raw materials to the factory and the works included were valued around 26 million HRK (equal to 3,5 million EUR). In the following period, until 2014 Našicecement provides complete Phase II which will allow the removal of cement from the factory building of additional infrastructure to transport systems, cement silos for loading and scales. The value of the second phase of works is estimated at 50 million HRK (equal to 6,6 million EUR) [8].

## 5 Conclusion

The construction of a special track for the cement factory Našicecement enabled multiple benefits: shorter transport time and energy saving, rational utilization of transport and labor, reducing transport costs, increasing traffic safety and reliability of the transport system and increasing the competitiveness of the factory on the market.

The idea of building a special track is common interest of factory Našicecement for cheaper and environmentally acceptable transport and interest of HŽ (Croatian Railways) to transport large amounts of cargo. Such an approach, with clearly defined common interest of users and the HŽ (Croatian Railways) is possible prerequisite for network expansion and modernization of industrial tracks as well as increase the volume of rail freight transportation.

## References

- [1] Zakon o sigurnosti u željezničkom prometu, Narodne novine 40/07, 61/11
- [2] Pravilnik o načinu i uvjetima za obavljanje sigurnog tijeka željezničkog prometa, Narodne novine 14/10
- [3] Dragič, Ž., Ivezić, T.: Industrijski kolosijeci i konkurentnost željeznice u prijevozu robe, Željeznice 21, 3, pp. 24-34, 2008.
- [4] Tuškanec, M.: Trendovi razvoja industrijskih kolosijeka u Republici Hrvatskoj, Željeznice 21, 2, pp. 19-26, 2009.
- [5] Klečina, A., Štefičar, S.: Revitalizacija industrijskih kolosijeka u Hrvatskoj, Željeznice 21, 1, pp. 36-46, 2010.
- [6] <http://www.szz.hr/revitalizacija-industrijskih-kolosijeka>
- [7] Alduk, W., Vrselja, D., Kegalj, A: Izgradnja posebnog kolosijeka za potrebe tvornice 'Našicecement,' Željeznice 21, 4, pp. 28-32, 2010.
- [8] <http://www.nexe.hr>
- [9] Pravilnik o tehničkim uvjetima za sigurnost željezničkog prometa kojima moraju udovoljavati željezničke pruge, Narodne novine 128/08



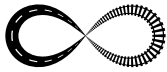

## TOURIST POTENTIAL OF THE INDUSTRIAL RAILWAY NETWORK IN BARANYA

Sanja Lončar–Vicković, Dina Stober, Zlata Dolaček–Alduk  
*Faculty of Civil Engineering Osijek, Croatia*

### Abstract

Baranya is a region in eastern Croatia, bordered by the Drava and Danube rivers, marked by the construction of industrial railway network, consisting of factory and forest tracks, in the early 20th century. The main railway line was oriented north-south, leading to Hungary, and it still exudes a dominant influence in Baranya's space. Historically and politically defined, the east-south route was discontinued around the year 1950 due to unprofitable existing infrastructure and the financial inability of the reconstruction. Disproportionate development of the observed polarization and the space around the existing infrastructure is the starting point of this research. The paper will show the network of industrial railways in Baranya, complete with railway stations, the first stop being in Baranjsko Petrovo Selo and the last, eighth station in Batina. The railway was closed and removed in 1968, and its physical disappearance left a trace, a route which, because of its technical characteristics of the substrate lines, is now used for moving agricultural machinery. This paper describes an integrated, interdisciplinary approach to the complex possibilities of revitalization of the missing line and its existing stations, defined and developed within the work of group of teachers and students of the Faculty of Civil Engineering in Osijek. Our concept incorporated regional and local strategic issues in a vision of a tourist route for sustainable vehicles like bicycles, horses, joggers, pedestrians, skiers etc. Railway station buildings still standing along the corridor should, with its newly developed contents, meet the needs and preferences of its users while simultaneously supporting the development of Baranya as a tourist region.

*Keywords: Baranya, industrial railway, architectural heritage, tourist routes, revitalization concept*

### 1 Introduction

The process of obtaining independence and establishing sovereignty of the Republic of Croatia that took place at the end of the 20<sup>th</sup> century was marked by armed conflicts, hardships and population migrations. The state of emergency led to the depopulation of the border regions and inhabitants' exodus to the outskirts of large and medium towns. These processes resulted in the corridor development of urban structures and an irregular spatial development; during that process underpopulated parts of Croatia remained well preserved but were not used in an optimal way.

Such spatial changes took place in the Baranya region in Eastern Croatia while it simultaneously experienced post-war 'socio-demographic depression'. In order to react to these changes, teachers and students at the Faculty of Civil Engineering in Osijek conducted a series of workshops in the area. One of the workshops, called 'Where is the Railway? ', was oriented towards the tourist potential of industrial railways and its complementing structures in Baranya.

## 2 Baranya – regional contemporary issues

### 2.1 Spatial and demographic facts

Baranya is a mostly rural region in eastern Croatia, a border zone to Hungary and Serbia. The Croatian part of the Baranya area, 1149 km<sup>2</sup> in surface, is defined by natural boundaries: the Danube in the east, the Drava to the south and south west, and administrative northern and north-western border with Hungary. Baranya belongs both to the Danube and the Drava River basins. Consistency of its climate is the result of small differences in elevation within the area where the highest peak is 273 m above the sea level and extends diagonally along Baranya Highlands - Banska Kosa - from southwest to northeast. This terrain introduces a number of elements into the Baranya area to which the space has diversified (binding settlements to the space of lowlands and highlands contact, an area suitable for vineyards, orchards) within a homogeneous plain. Croatian Baranya is a part of a larger historical and geographical unit; the division of the County of Baranya into Croatian and Hungarian Baranya was determined by the Trianon peace in 1920. The major part of Baranya today is positioned within the Republic of Hungary (80% of the territory).

In the past, Baranya was involved in various political integrations which set the guidelines for development in alternate directions: north-south and east-west. The multi-layered development of Baranya's net of settlements could be seen as a positive outcome of these processes. Therefore, the disintegration of Baranya's space into the polarization corridor and "the rest" is not necessarily a negative fact. The polarization belt from Bilje to Kneževo is getting more important at the moment and is expected to get even more importance with the finalization of the north-south Baranya part of the European road corridor 5C connecting Budapest and Ploče. Is it necessary to wait for more people to relocate into the urban corridor so that the rest of Baranya could experience the positive effect of the improved infrastructure [1].

### 2.2 Industrial railway network in Baranya

In mid-19th century, the population of Baranya was oriented towards agriculture. Industrial production occurred in form of rural crafts and agricultural plants and was experiencing rapid growth [2]. At the beginning of the 20th century, the area of Baranya was marked by an economic bloom. In this context it was inevitable that new, planned settlements for industrial workers would emerge across Baranya, presenting vibrant points in space, and positively contributing to its progress.

The infrastructure was rapidly developing, and the historic north-south railway connection was enriched by railway trails in the east-west direction. There were three railway routes in the Baranya triangle in that period – the state line, direction north-south; the industrial line, west-northeast; and the agricultural line, west-east (Fig.1).

Establishing a network of planned settlements was associated with the transport corridor of the agricultural state property Belje industrial railway. That industrial network, built between 1906 and 1915 as an investment of Belje, was a narrow-gauge railway, the distance between the rails being 0,76 meters. It is important to state that, although it was an industrial railway in its origin, it continuously served as means of public transportation as well.

Map copies and originals depicting the railway tracks and bridges, dating from 1925, are available in the State Archives in Osijek, testifying to the simultaneous design and construction of railway tracks with the establishment of planned settlements. Maps show an organized and planned network within Belje with hierarchically marked railway stations. Hierarchy of station categories is visible in the map: the most important being the "emperor's" waiting room station, then stations equipped with a telephone switchboard and the final station - the navigable station Kazuk. We can conclude that these networks significantly influenced the development of intensive and advanced communications within the space of Baranya.

Between 1948 and 1952, 71% of goods in Baranya were transported via industrial rail tracks (then 119 kilometres long). Described railway traffic structure held till the end of the 60s', when the road traffic took over, and the industrial railway became unprofitable. The fact that the replacement system could not follow all the benefits of train transportation facilitated the depopulation of rural areas. The state policy at that moment did not see railway traffic as important and has therefore abolished existing lines. Actual deconstruction of the industrial railway track was carried out in 1968. Today's length of the Baranya railways amounts to just 44% of the old ones and the whole area is marked by the polarization of the population and the economy around the main road and railway corridor, direction north-south [3].



**Figure 1** Review of Baranya county railway infrastructure; existing and dismantled railway tracks with station positions.

### 3 Baranya- tourism development potentials

#### 3.1 Tourism as a factor of growth

The tourism sector is a key driver of economic growth and employment and has a fundamental role in meeting the objectives of the Lisbon strategy: making the EU the most competitive and dynamic economy in the world. Tourism can be seen to impact almost every other sector, from transport to engineering and from architecture to agriculture. It is one of the fastest expanding sectors of the European economy as well as in Baranya in spite of its historical predominantly agricultural image.



While the attractiveness of 21<sup>st</sup> century's tourist destinations is largely reliant on authenticity and uniqueness of landscape scenery, loss of traditional regional characteristics degrades its tourist value. The objectives of the „Where is the Railway“ student workshop followed the principles of ICOMOS Charter on the built vernacular heritage and ICOMOS International cultural tourism charter, both delivered in Mexico, 1999 – importance of research, documentation and use of non aggressive research methods in preserving natural and cultural heritage, public access to research results; maintaining the continuity of traditional ways of construction and training in the field of traditional knowledge and skills [4]. The 2004 recommendations of the UN-World Tourist Organization [5] state three most important characteristics of sustainable tourism: optimal use of resources from the environment, respect for social and cultural aspects of local communities while preserving the existing architectural cultural heritage and ensuring long-term economic viability of all stakeholders. European Commission has also adopted, in October 2007, an Agenda for a sustainable and competitive European tourism.

### 3.2 Tourist routes in the region

We based our proposal for re-use of the Baranya industrial railway route on the research of several existing tourist routes in the vicinity. Croatia has a long tradition of tourist routes and actions that this project proposal is leaning on like the Napoleon route on Pelješac island, Truffle roads in Istria, Wine roads of Ilok, Boat route through Spacva woods, Golden Thread roads in Slavonia and, most important, the Wine route project that connects the Batina World War II memorial with the Dubosevica village, located in this area. This cross border area is also already connected through a network of bicycle roads like the Panonian Peace Trail Bike Tour and parts of the Danube bicycle road. The Panonian Peace Trail (Via Pacis Panonnie) is 80 kilometres long, positioned between Osijek and Sombor and in function since 2006. One important example that was based on a similar concept as the one we envisioned is the Parenzana project. Parenzana is the name of the former narrow-gauge railway line that connected Trieste with Poreč, together with 31 other Istrian cities, located today on the territory of three states. It was operational since 1902 and stopped operating in 1935, because of cheaper road traffic solutions. Long forgotten, it came to life in 2006 within the Parenzana: Trail of health and friendship project, a program of tourist valorisation of the Parenzana that turned its track into a recognizable bicycle marathon. The Parenzana II: Revival of the trail of health and friendship project started in 2009 and is expected to end this year.

### 3.3 Revitalization concept for industrial railway network in Baranya

Kušen notes that there are sixteen basic attractions associated with tourist locations; geological features, climate, water, flora, fauna, protected natural heritage, protected cultural heritage, the culture of life and work, famous persons and historical events, special events and happenings, cultural and religious institutions, natural spas, sport and recreation facilities, tourism paths, trails and roads, attractions for attractions and tourism para-attractions [6]. Tourist routes, as mentioned in the Parenzana example, but especially in the case of Baranya, include several of these characteristics; geological loess structures, a nature park with the abundance of waterways, protected flora and fauna, the culture of life and work - wine tourism, rural tourism, hunting tourism. Forming tourist routes is a concept of merging several locations of similar interest in order to make a holistic tourism product. In this case, the similar interest is preserving the spatial memory of the railway tracks.

In the case of Baranya's industrial railway network, after the dismantling and destruction of the tracks in 1968, all that was left were seven abandoned railway stations along the route - silent witnesses of a disappeared infrastructure. Those stations – Zmajevac, Suza, Kneževi Vinogradi, Karanac, Petlovac, Baranjsko Petrovo Selo and Širine - are left standing in a suburban, rural area, faced with depopulation and stagnation. Profiling this area in terms of susta-

inable rural tourism was a challenge to a group of 20 students and teachers of the Faculty of Civil Engineering Osijek and the main goal was set - recycling the railway track. The process of creation of the route consisted of various activities – research activities, modelling of the route and design of its contents. It started around analysis of collected data, both architectural and structural, as well as on a detailed SWOT analysis of the potentials of railroad route as an entity as well as for specific objects. By developing the SWOT analysis for the whole route students set out a full vision and consequently defined contents for the route from the west to the east and back.

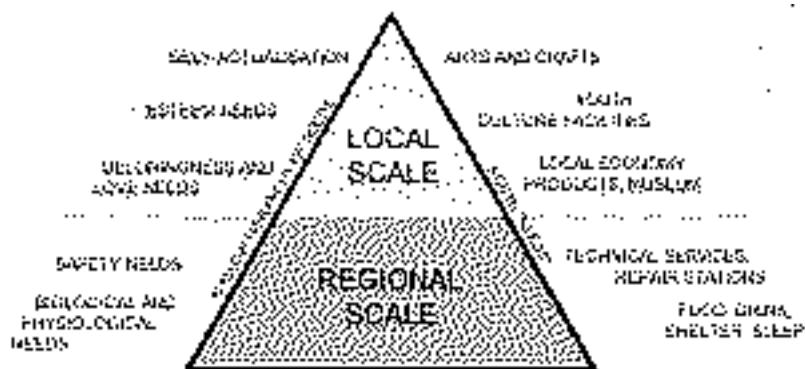

Figure 2 Distribution of tourist contents on regional and local scale according to Maslow hierarchy of needs.

The first step in designing the workshop was to explore and determine the conditions that preceded the polarization of the network of settlements in Baranya. The research revealed that the east-west direction was once supported by standard-gauge railroad which was used for freight and passenger traffic. The railway connected the Republic of Hungary on the western border of Baranya with the first station in Baranjsko Petrovo Selo and continued with a series of stations. The concept set to revive the imprint of the railway as a traffic route for vehicles like bicycles, horse carriages, pedestrians, Nordic skiers etc. The seven stations along the traffic corridor were supposed to fulfil the needs and wishes of the users (with their contents) as well as to contribute to the development of Baranya as a tourist region with its gastronomic offer from the local resources.

The next step was to adjust content to micro location; the object near the village with a strong gastro tradition supported the development of the micro location and became a point on the route which provides consummation. Other contents were distributed on other locations in the same way. The following contents were anticipated: inn with a horse-stable, multipurpose room for gatherings (NGOs, group's et al), museum and souvenir shop, a restaurant, a wine house, a hotel and a cycle repair service.

The last step was to set a concept of rebuilding each station considering the shape of the object. Severally devastated buildings were revitalized by modern technical solutions, while objects in good condition were modified in a way that the current condition stays as close to the original as possible (Fig.2).

The concept of sustainability of the planned route is based on a sequence of locations connected in a continuous circle. It is a chain of small scale rings that could always be 'changed' and 'repaired' according to local development trends so the main chain will not be 'broken'. Every small scale ring represents one location - a station building supported with complementary, already existing, contents like wine, gastronomy, archaeology etc (Fig.3).

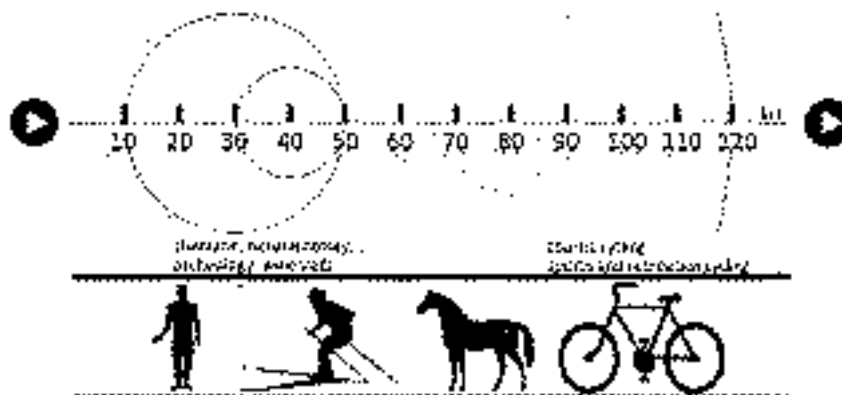

Figure 3 Model of a sustainable tourist route based on distances between stations [7].

## 4 Conclusion

European experiences with reviving railway routes and stations brought together partners from five European countries in the RARE project (within the Interreg IIIB CADSES program), with the aim to regenerate areas of railway stations in the urban fabric. Spaces chosen in the RARE project were abandoned and under-utilized but, at the same time, were located in central areas of cities where land availability achieved great value and where land demand was high. Issues that have shaped the parameters for the assessment of their potential are directly related to the context and the specific area (space characteristics, previous and current location purposes, possible advantages of location). Therefore, identifying and connecting with the location was the first step in the process of revitalization of railway infrastructure.

On a smaller scale, we tried to implement this frame on the example of an industrial railway network in Baranya. The concept of its revival started with a broader survey of regional issues (Baranya), continued based on local requirements (settlement network) and was implemented according to micro location status (station buildings).

Although our work remains currently in the field of ideas and concepts, it started a process of raising awareness towards the issue of forgotten industrial heritage of Baranya.

## References

- [1] Lončar-Vicković, S., Stober D.: A Contribution to Settlement Network Analysis in Baranya – a Projection of Spatial Development, Tehnički vjesnik, 17, pp 83-91, 2010.
- [2] Tri stoljeća Belja, IAZU, Zavod za znanstveni rad Osijek, Osijek 1986.
- [3] Bušelić J.: Supstitucija ukinutih nerentabilnih željezničkih pruga, Ceste i mostovi u Hrvatskoj, Republički fond za ceste i potpisnici Sporazuma o financiranju i korištenju monografije, pp 161-167, Zagreb 1975.
- [4] UNESCO ICOMOS, Venice Charter, International charter for the conservation and restoration of monuments and sites, 1964.
- [5] UN-WTO, Sustainable Development of Tourism, Handout1-2, 2004, <http://www.unep.fr/scp/tourism/sustain/>
- [6] Kušen, E: Turizam i prostor - Klasifikacija turističkih atrakcija, Prostor 4, pp1-14, 2001.
- [7] Fikfak, A., Rozman, M.: Trajnostni razvoj in ekoturizam: razvoj omrežja turističnih poti, *Academica Turistica II* (3-4), pp 14-23, 2009.

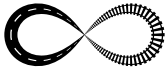

## OVERVIEW OF THE RAILWAY LINE ZAGREB–RIJEKA AS PART OF THE SPATIAL–TRAFFIC STUDY OF THE PRIMORJE–GORSKI KOTAR COUNTY AND THE CITY OF RIJEKA

Stjepan Kralj

*Institut IGH, d.d., Croatia*

### Abstract

The Primorje – Gorski Kotar County is situated between Dalmatia, Central Croatia and Slavonia. The Bay of Kvarner (Port of Rijeka) is well connected with the Pannonian valley with the traffic routes passing through the Kupa River valley. The Primorje – Gorski Kotar County is especially important when considering inland traffic connections between the Pannonian and the Adriatic territories, as well as for the traffic connection of the Mediterranean with the Central European territories. The nodes of the main road and railway traffic routes (Branch of the corridor Vb and the Adriatic – Ionian motorway), road, railway, sea and air traffic terminals are all concentrated in the Rijeka agglomeration. This fact, along with the relief characteristics of the coastal area and its abundant biodiversity characterize the complexity of the problem with regard to the solution of the overall traffic node.

The complexity and management of individual traffic infrastructure segments at different administrative levels along with the spatial development of the area require a certain level of coordination and solution to the conflicts within the overall traffic network of the area.

The already existing, planned elements of individual traffic networks are linked into an agglomeration of defined and composite traffic networks (road, railway, sea, air traffic etc.), and along with all adjoining elements (zones used for traffic etc.) form and integral traffic node – the Rijeka node, which includes public and individual traffic, i.e. passenger and cargo traffic. An integral network of passenger and cargo traffic in the Rijeka node had to be outlined, as an element of development according to the spatial planning principles as well as general goals of overall development of the Primorje–Gorski Kotar County.

The aim of the Study was a long-term and integrated definition of development of the Rijeka traffic node.

*Keywords: traffic, traffic network, railway, railway traffic, motorway, spatial development plans, environmental protection, feasibility, bridge,*

### 1 Introduction

'Integral Physical Planning and Traffic Study for the Primorje and Gorski Kotar County and the City of Rijeka' (the Study) deals with the integral traffic system of the Rijeka Junction with road, marine, railway and combined transport, air traffic and pipeline transport (gas pipelines, oil pipelines and product lines) on the territory of the Primorje and Gorski Kotar County and bordering areas with the neighbouring counties.

The traffic junction Rijeka is dealt with in more detail for the area of Rijeka agglomeration – the City of Rijeka with the surrounding system of towns and municipalities within the Rijeka ring: Opatija, Matulji, Jelenje, Čavle, Kastav, Viškovo, Kostrena, and functionally relevant surrou-

ding area consisting of the following towns and municipalities: Omišalj, Lovran, Kraljevica, Bakar, Klana, Crikvenica, Novi Vinodolski, Vinodolska Municipality and Fužine.

The Zagreb–Rijeka railway line, as a part of the Pan European Vb corridor branching road Budapest–state border Botovo–Zagreb–Rijeka, enters the county territory at Velika Kapela and extends to the east edge of the town (Krasica). In the context of the future Adriatic–Ionian route, the railway line extends further through the complicated urban network towards the west, towards Slovenia and Trieste.

Of all the traffic systems analysed in the Study, this paper will examine in more detail the railway transport system, i.e. the positioning of the new high performance railway line Zagreb–Rijeka–Slovenia (Trieste).

## 1.1 Study Goals

The goal of the Integral Physical Planning and Traffic Study for the Primorje and Gorski Kotar County and the City of Rijeka was to define the long-term and integral development of the traffic junction Rijeka.

The existing, proposed and newly-planned elements of certain traffic networks is connected into a group of specified and composite traffic networks (road, railway, marine, air and other) together with all corresponding elements (zones in the function of traffic etc) and constitutes the integral traffic junction Rijeka, which includes public and individual, i.e. passenger and freight transport. The development of the integral network of passenger and freight transport of the Rijeka junction was supposed to be clarified in terms of space and physical possibilities in keeping with the physical planning principles and general development objectives for the Primorje and Gorski Kotar County.

The main goal of the physical planning segment of the Study was to realise, by interactive superposition of traffic networks, assessment of options and assessment of possible impacts, a long-term solution for the traffic junction Rijeka, from the aspect of a steady physical development, coordinated with the economic and social requirements, requirements of environmental protection and cultural values, and in keeping with physical planning principles and general development objectives for the Primorje and Gorski Kotar County (1995–2015).

## 1.2 The Scope of the Integral Physical Planning and Traffic Study

The study is conceptually conceived through three parts: physical and technical study, traffic study and pre-feasibility study. Physical and technical study analyses the existing condition, the existing study and planning documentation, previous and new solutions for certain modes of transport and economic basis in terms of the County territory.

The physical planning part provides an overview of strategic (planning) documents on the state level, and overview of relevant data from the Primorje and Gorski Kotar County Physical Plan and the basis for a detailed analysis on the local level (town and municipality plans).

The scope of separate studies (technical part) of certain modes of transport (road, railway, marine and air) and of public traffic has been determined in accordance with the scope and significance of a particular traffic junction within the external network.

The traffic study for the area specifies the coverage area and the goals of the study itself, specifies the methodological origins for study development, analyses the existing traffic streams and traffic operation, considers variations of developing traffic supply by systems, their upgrade or reconstruction, considers new variations and their combinations, and provides a proposal for the development of traffic demand for each mode of transport and an overall traffic demand.

The pre-feasibility study analyses the existing traffic streams and traffic operation, considers variations of developing traffic supply and dynamics by systems, their upgrade or reconstruction, considers new variations and their combinations, analyses investment costs,

analyses the feasibility of certain solutions by systems, plans and proposes the progress of work realisation.

Traffic junction Rijeka is formed at the end of the Pan European corridor Vb motorway (Budapest – Zagreb – Rijeka), the Adriatic – Ionic Motorway segment (Trieste – Rijeka – Split – Bar – Drač – Athens), which also functions as a bypass for Rijeka agglomeration, the railway corridor v (Budapest – Zagreb – Rijeka) and the Port of Rijeka. The main airport in the county is located on the island of Krk, as well as the existing and newly-planned port facilities.

The complexity and method of managing individual segments of traffic infrastructure at different administrative levels, as well as managing physical development, creates the need for coordination and for solving conflicts within the overall traffic network in the area.

## 2 Methodology

The approach to the study development is multidisciplinary, and includes consideration and elaboration of all economic and physical planning advantages, as well as environmental and other consequences of (not) upgrading traffic infrastructure on the Primorje and Gorski Kotar County territory.

Physical and technical study consists of a few stages and units with individual goals for each stage of Study development:

- a Analysis of the study and planning documentation, existing and planned condition, with subsequently included newly-planned interventions.
- b analytic set of maps,
- c analysis of the existing and planned condition,
- d formation of the basic traffic network,
- e basis for laying and evaluating route variations from study solutions from the aspect of physical planning,
- f an overview of basic data about the area from the planning documentation,
- g a proposal for categorising the overall traffic network
- h physical and functional organisation of the County territory in terms of an integral traffic network
- i physical organisation of the County, including quantification of the origin/destination of the existing and planned traffic demand
- j an overview of possible solutions and data from separate studies: railway and road traffic network, marine traffic, air traffic and public passenger transportation
- k description and significance of main traffic routes in terms of space and geography
- l detailed analyses – separate technical data for the proposal for amendments to the planning documentation
- m concluding remarks – an overview of the necessary amendments of the planning documentation in relation to the traffic network and other innovations proposed by the study

Input data for physical and traffic planning and network design are taken over from the Primorje and Gorski Kotar County Physical Plan (hereinafter: PGKC PP), PPPPO (physical plans for areas with special features) and documents formed on the basis of data from physical plans for municipalities and towns.

Traffic study set as its goal the interconnection of the entire traffic system which includes public and individual, road and railway, air and marine traffic as well as pipeline transport. The accelerated development strategy of the City of Rijeka and Primorje and Gorski Kotar County traffic systems should be analysed through some of the following aspects:

- Presenting available road/railway routes and port terminals, as well as feasible and proposed required short-term interventions in upgrading and reconstructing the existing traffic system

- Analysing the structure of the road and railway network and terminals on the territory of the City of Rijeka and Primorje and Gorski Kotar County,
- Proposing strategic, long-term road and railway routes and facilities, as well as required short-term interventions in upgrading and reconstructing the existing road and railway network,
- Analysing the types of regular public passenger transport services (road, railway, marine, air, combined) and specifying elements for the realisation of an integral regular public passenger transport services on the territory of the City of Rijeka and Primorje and Gorski Kotar County,
- Analysing the structure of airports and sea ports open to public transport on the territory of Primorje and Gorski Kotar County,
- Analysing the network and structure of pipelines on the territory of the Primorje and Gorski Kotar County.
- Proposing stages, dynamics and functionality of the construction of the entire traffic system for the period of 5, 10 and 20 years,
- Proposing, based on the performed analyses, the necessary amendments to the physical planning documents.
- The traffic study, within an integrated solution, should have also analysed the following issues:
  - The traffic solution should have evaluated the proposal for an intermodal transport centre,
  - The study should have also proposed and justified in terms of traffic the new route of the motorway ring around Rijeka,
  - The study should have proposed an integrated railway infrastructure network on the territory of Primorje and Gorski Kotar County and the Rijeka railway junction,
  - A categorisation of road transportation facilities,
  - A solution proposal should have been provided for parking facilities at contact points of different transportation modes – the Park & Ride concept.
- Analysing the performance of traffic systems and availability of traffic systems.

### 3 Position of the new valley railway line within the county traffic network

The Primorje and Gorski Kotar County is positioned centrally in relation to Dalmatia, Central Croatia and Slavonia. The shortest connection of the Kvarner Bay (the Port of Rijeka) with the Pannonian plains is through the valley of the river Kupa. The Primorje and Gorski Kotar County is of special significance for internally connecting the Pannonian and Adriatic regions in Croatia and for connecting the Mediterranean by traffic with the central European regions. Main routes of road traffic (Corridor Vb and the Adriatic–Ionic motorway), terminals of road, railway, marine and air traffic all connect and are concentrated in the Rijeka agglomeration area.

The transport route along the corridor Vb branch road is of an especially large significance for the economy in Hungary, Slovakia, Ukraine, Poland. and is used to transport export/import freight for the requirements of the economy. Expectations are great for the increase in the number of containers being transported to/from Rijeka and to/from the territory of Hungary. These expectations will be even greater after the upgrade and construction of a new container terminal in Rijeka, because it is the most cost-effective route towards the ports in the Adriatic. This route is the fastest and most cost-effective route for the regular transport of passengers between Hungary, Russia and the Ukraine towards Italy and holiday destinations in the Adriatic. A growing interest in the regular passenger transport towards Italy and the Adriatic is to be expected, since travel time will be significantly reduced along the new railway line. The increased purchasing power of the citizens of Hungary, Slovakia and Poland is an issue, resulting even now in an ever-growing interest in spending vacation time on the Adriatic coast, along with the development of seasonal tourist transport, already yielding excellent results.





- Construction of the remaining sections of the Adriatic–Ionic railway line which pass through Croatia to Rijeka, via Drežnica to Split and Ploče,
- Reconstruction and modernisation of the railway junction Rijeka,
- Realisation of the transport project Danube Basin–Adriatic, which includes modernisation of the existing and construction of new capacities for the port of Rijeka, a new valley railway line Zagreb–Rijeka, upgrade of the river ports in Sisak and Slavonski Brod, ensuring the navigability of the river Sava through the entire year, from Sisak to Vukovar, including the construction of a multipurpose channel Vukovar–Šamac,
- Construction of the Zagreb railway junction, with new bypass lines, which would facilitate an unhindered flow of through traffic over corridor x and a branch of corridor Vb through a wider Zagreb and Zagreb County area,
- Construction of other capacities not mentioned here in the catchment area of the new railway line.

The forecast itself predicts global scenarios for the construction of large infrastructural facilities which are closely linked with the construction of the new valley line Zagreb–Rijeka, such as:

- necessary interventions at the existing capacities within the Rijeka junction and on the existing railway line in order to increase the efficiency of the railway operations,
- construction of new capacities (railway line, container terminals, intermodal centres etc).

As mentioned above, the corridor for the new line enters the County territory after the Drežnica railway station (Velika Kapela), where the corridor towards Dalmatia (Adriatic–Ionic) has been proposed.

A new double track railway Horvati–Karlovac–Drežnica–Krasica has been planned in sector III at the mentioned railway transport route. On the territory of Skradnik, a single track line connection would be constructed onto the existing railway line Zagreb Central Station–Rijeka and the existing railway route Oštarije–Split.



**Figure 2** Proposed option for the construction of the new valley railway at sector III Zagreb – Rijeka (Option 1C)

The new Krasica railway station would be connected onto the existing railway line Zagreb Central Station–Rijeka via the connecting line Krasica–Tijani. After construction in sector III is complete, the new double track line Horvati–Karlovac–Drežnica–Krasica–Tijani would replace the existing railway line Zagreb Central Station–Rijeka on section Horvati–Tijani as a part of

the future railway transport corridor 2 of the Trans-European railway network on the territory of the Republic of Croatia. Section Horvati–Karlovac–Ogulin–Delnice–Škrležovo–Tijani on the existing railway line Zagreb Central Station–Rijeka would no longer hold the status of the main corridor railway line and would become a railway line of significance to regional transport. The properties of the new line will facilitate traffic of far heavier trains than the ones operating along the existing line. The abovementioned information indicates that the railway capacity expressed in gross tons of transported goods will be over 10 times larger than the capacity of the existing line, and that the line will facilitate transport of the predicted number of trains. Taking into consideration high classification and required technical elements, as well as the complexity of the terrain relief and the importance of the region, a series of tunnel structures appear on the railway route.

Subsection Drežnica–Ledenice (20.47 km) from the Drežnica station to the highest point of the railway line at 483.7 m above sea level, which is located inside the Kapela 2 Tunnel, 14,428 m long, at an upward grade of 5 mm/m, and after this point the line is at a downward grade of 7.6 mm/m. The line then passes through tunnels Burnjak (1,530 m), and Vranja (350 m) and reaches the new Ledenice station.

**Table 1** Freight traffic forecast on the new valley railway line by sections

Traffic forecast	2015.	2020.	2025.	2030.	2035.	2040.
Line: Krk–Krasica				8.344.800	12.557.400	16.770.000
Route: Krk–Krasica				4.172.400	6.278.700	8.385.000
Route: Krasica–Krk				4.172.400	6.278.700	8.385.000
Line: Rijeka–Krasica			9.664.745	9.285.120	10.068.684	11.461.846
Route: Rijeka–Krasica			5.798.847	5.700.355	6.165.646	7.142.515
Route: Krasica–Rijeka			3.865.898	3.584.765	3.903.038	4.319.331
Line: Krasica–Drežnica			9.664.745	17.629.920	22.626.084	28.231.846
Route: Drežnica–Krasica			3.865.898	7.757.165	10.181.738	12.704.331
Line: Drežnica–Goljak			11.739.187	20.800.080	26.655.794	35.385.326
Route: Drežnica–Goljak			7.043.512	12.896.050	15.993.477	21.231.196
Route: Goljak–Drežnica			4.695.675	7.904.031	10.662.318	14.154.130
Line: Goljak–Horvati		7.499.081	12.356.668	21.894.165	28.057.889	37.246.594
Route: Goljak–Horvati		4.274.604	7.043.512	12.896.050	15.993.477	21.231.196
Route: Horvati–Goljak		3.224.477	5.313.156	8.998.115	12.064.412	16.015.399
Line: D. Selo–Gradec	4.866.209	5.356.486	7.268.629	10.947.082	13.360.900	16.636.284
Route: Dugo Selo–Gradec	2.919.725	3.213.892	4.361.177	6.787.191	8.016.540	9.981.771
Route: Gradec–Dugo Selo	1.946.483	2.142.595	2.907.451	4.159.891	5.344.360	6.654.514
Line: Gradec–Križevci	4.686.209	5.166.486	7.068.629	10.667.082	13.060.900	16.331.284
Route: Gradec–Križevci	2.829.725	3.118.892	4.261.177	6.647.191	7.866.540	9.829.271
Route: Križevci–Gradec	1.856.483	2.047.595	2.807.451	4.019.891	5.194.360	6.502.014
Line: Križevci–Koprivnica	4.746.209	5.236.486	7.148.629	10.767.082	13.170.900	16.446.284
Route: Križevci–Koprivnica	2.859.725	3.153.892	4.301.177	6.697.191	7.921.540	9.886.771
Route: Koprivnica–Križevci	1.886.483	2.082.595	2.847.451	4.069.891	5.249.360	6.559.514
Line: Koprivnica–Botovo (SB)	4.396.209	4.736.486	6.548.629	9.867.082	12.170.900	15.346.284
Route: Koprivnica–Botovo	2.572.112	2.836.693	3.868.592	6.023.630	7.124.842	8.892.422
Route: Botovo–Koprivnica	1.824.096	1.899.793	2.680.036	3.843.452	5.046.058	6.453.862

**Table 2** Freight traffic forecast on the new valley railway line by sections in mil. passengers/year

Section	2015.	2020.	2025.	2030.	2035.	2040.
Line: Krasica–Drežnica	2,90	3,50	4,20	4,32	4,90	5,06
Route: Krasica–Drežnica	1,45	1,75	2,10	2,16	2,45	2,53
Route: Drežnica–Krasica	1,45	1,75	2,10	2,16	2,45	2,53
Line: Drežnica–Goljak	4,74	5,60	6,40	6,58	8,50	8,76
Route: Drežnica–Goljak	2,37	2,80	3,20	3,29	4,25	4,38
Route: Goljak–Drežnica	2,37	2,80	3,20	3,29	4,25	4,38
Line: Goljak–Horvati	4,30	5,10	5,80	6,20	7,80	8,00
Route: Goljak–Horvati	2,15	2,55	2,90	3,10	3,90	4,00
Route: Horvati–Goljak	2,15	2,55	2,90	3,10	3,90	4,00
Line: D. Selo–Gradec	3,38	4,00	4,50	4,60	5,00	5,10
Route: Dugo Selo–Gradec	1,69	2,00	2,25	2,30	2,50	2,55
Route: Gradec–Dugo Selo	1,69	2,00	2,25	2,30	2,50	2,55
Line: Gradec–Križevci	2,48	3,07	3,54	3,63	3,90	3,95
Route: Gradec–Križevci	1,24	1,535	1,77	1,82	1,95	1,975
Route: Križevci–Gradec	1,24	1,535	1,77	1,82	1,95	1,975
Line: Križevci–Koprivnica	2,68	3,37	3,88	3,99	4,30	4,40
Route: Križevci–Koprivnica	1,34	1,685	1,94	1,995	2,15	2,200
Route: Koprivnica–Križevci	1,34	1,685	1,94	1,995	2,15	2,200
Line: Koprivnica–Botovo (DG)	0,50	0,60	1,20	1,30	1,80	1,86
Route: Koprivnica–Botovo	0,25	0,30	0,60	0,65	0,90	0,93
Route: Botovo–Koprivnica	0,25	0,30	0,60	0,65	0,90	0,93

Subsection Ledenice–Krasica (25.98 km). After the Ledenice technical station the route enters the Vinodol Tunnel (9,300) in order to avoid unfavourable geological zones as well as the impact of the line on protected areas of the Vinodol Valley. The route is at a downward grade along its entire length to the new Krasica station, with the rail axis slope of 8 mm/m in the tunnels and 12.4mm/m outside the tunnels. The following tunnels are located on this subsection: Vinodol (9,270 m), Kozja Draga (1,370 m), Veli Dol (4,730 m), Biljin (2,250 m), and viaducts: Antovo (1,000 m), Vinodol (1,440 m) and Praputnjak (920 m).

The line route from the Skradnik station to the Krasica station is very demanding in terms of construction works and exploitation because there are structures along 76.56%, i.e. 51,292 m of the route. Route under option c meets all geotechnical requirements specified by the geotechnical report on the territory of the Vinodol Valley.

In sector IV a connection of the said railway traffic route is planned onto the existing and future railway and port capacities in the wider Rijeka area, as well as onto the existing and future capacities for the passenger transport in the Rijeka area; a connection is also planned onto the existing railway line towards Slovenia and a new connection onto the railway network in Istria. The most important interventions include the construction of the new connecting line Krasica–Ivani, further on with the connection onto the existing Škrlijevo – Bakar railway line, of the new bypass and connecting Krasica–Tijani–Matulji–Istria railway line and connecting line from Krasica to the planned new port capacities on the island of Krk.

By constructing a tunnel and a railway line for connecting corridor Vb branch onto the Istrian railway network and by possibly continuing the construction of the line through Istria towards Trieste, the connection between the corridor Vb branch and corridor V might be achieved in Trieste as well.

## 4 Options for the railway traffic junction development

The new redefined solution of the Rijeka railway junction has to meet the functional requirements of the port and other economic agents, i.e. the City of Rijeka and its residents, with maximum protection and undisturbed development of other urban functions. This also means that the capacities for freight transport would be dislocated to the highest degree possible from the inner city circle to its peripheral areas (Krasica, Kukuljanovo, Bakar, Ivani, Bršica, Krk etc.), while the passenger transport facilities would be efficiently incorporated into the physical and traffic plan for the city of Rijeka. This applies particularly to the railway being included into the urban and suburban passenger transport, which might significantly improve transport services in the narrow and wide Kvarner region, from Opatija and Rijeka all the way to Crikvenica and Novi Vinodolski.

Modelling the Rijeka railway junction was a complex project, both technically and technologically. This complexity is caused by a number of limitations which hinder a logical and rational approach to finding an optimal traffic solution. One of the greatest limitations is certainly a lack of adequate surface area onto which to arrange railway facilities in a technologically most appropriate succession.

The second largest limitation is certainly the existing level of development of the railway and port infrastructure which should be utilised to the utmost degree and functionally incorporated into the new solution for the Rijeka junction.

And finally the third limitation is the obligation to adhere to the urban and physical development plans for the city of Rijeka, and accordingly the port and the railway should not hinder its development.

Along with the abovementioned limitations, there were also several other limitations in implementing the conceptual solution to the Rijeka railway junction, such as water and environmental protection, etc. All this played a part in redefining the role of the junction and in the arrangement of particular facilities in accordance with the proposed concept.

The mixed traffic line from the Krasica station to the port of Omišalj has been devised as electrified and double-track, and has been considered through a number of options with a new bridge to the island of Krk. All considered options from the land–Krk bridge to the location of Blatna end at the port terminal in Krk next to the future logistics and distribution centre.



**Figure 3** New railway connection at Vitoševo (direct link between Ivani and Rijeka and Brajdica) – (stage III of the junction construction)

The railway route from Krasica to Matulji has been considered through two options 'at elevation 200' and 'at elevation 300' with several variations (in plan view, detailed grade line, shorter–longer tunnels). The problem in making a final decision lies in the inability to run the route through developed areas, and to run through traffic through town, at the same time making sure that the line functions as urban and suburban passenger transport route.

The dilemma between elevation 200 or 300 still remains and requires additional investigation. The 'elevation 300' was considered as an option in order to force penetrating Ćićarija

(14,370 m) and rising to the elevation of the Jurdani station (341 m above sea level). This route achieves a shorter link to Trieste and a direct link to the large business zone after Jurdani (Miklavija). By the option 'elevation 200' and the Učka Tunnel (12,030 m) the railway link to Istria is realised from the Opatija–Matulji station (at the elevation of 211 m). This avoids running the route down the slopes of Učka above Opatija, but transit through central urban zones, the large business zone after Jurdani towards Slovenia, are not directly linked via good railway connections.



Figure 4 Integrated scheme of the Rijeka railway junction

## References

- [1] Conceptual Design for the High Performance Railway Line, State Border (Botovo) – Zagreb – Rijeka, IGH, Zagreb, 2008
- [2] Preliminary Design for the High Performance Railway Line, State Border (Botovo) – Zagreb – Rijeka, Subsection Skradnik-Ledenice, IGH, Zagreb, 2008
- [3] Physical Planning and Traffic Study for Road and Railway Traffic of the Wider Zagreb Area, IGH, Zagreb, 2008
- [4] Traffic Technology and Transport for the High Performance Railway Line Project, State Border (Botovo) – Zagreb – Rijeka, ŽDP, Zagreb, 2008
- [5] The Port of Rijeka Development Study, Maritime Rotterdam Group, 2008
- [6] 'Željeznička pruga velikih brzina Rijeka-Zagreb-Botovo (Budimpešta)', Predstudija, HAZU Zagreb, 1992. (High Speed Railway Line Rijeka – Zagreb – Botovo (Budapest), Prestudy, HAZU, Zagreb, 1992)
- [7] Croatian Parliament: National Programme for Railway Infrastructure for the Period between 2008 and 2012, Zagreb, March 2008
- [8] Croatian Office for Strategic Planning: Croatia in the 21st Century – Transport, Zagreb, September 2001
- [9] Study for Redefining Traffic and Physical Solution for the Rijeka Railway Junction, ŽDP, 2004
- [10] Feasibility Study for the High Performance Railway Line, State Border (Botovo) – Zagreb – Rijeka, IGH, 2011
- [11] Integral Physical and Traffic Study for the Primorje and Gorski Kotar County and the town of Rijeka, IGH, Zagreb, 2011
- [12] Training in High Speed Systems, uIC Paris 2007.
- [13] Urban Transportation Planning, Meyer, M.D., Miller, E.J., New York, 2001
- [14] Physical Plans for the Zagreb, Karlovac and Primorje and Gorski Kotar Counties

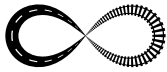

## ONE MODEL FOR RAIL INFRASTRUCTURE PROJECTS SELECTION

Dragana Macura<sup>1</sup>, Rešad Nuhodžić<sup>2</sup>, Nebojša Bojović<sup>1</sup>, Nikola Knežević<sup>1</sup>

<sup>1</sup> Faculty of Transport and Traffic Engineering, University of Belgrade, Serbia

<sup>2</sup> Railway Transport of Montenegro, Montenegro

### Abstract

The transport investment projects are high investments with long-term effects. Rail infrastructure projects are very important for economic and social development of the country. They influence on strengthen the competitiveness of railways in the transport market, as the only sustainable mode of transport. This paper researches the problem of railway infrastructure projects selection, such multicriteria problem. Considered projects are infrastructure projects of doubling rail tracks of Corridor 10 through Serbia. The aim of the model is the project selection and allocation of financial resources, based on their total contribution to company goals. The degree of effectiveness of each project individually is measured, whereby the selection of projects is made by the relative relationship. Beside economic and technological criteria for the transport project selection, developed model takes into consideration the impacts of relevant exterior projects. Their realization is uncertain and it's expressed by the initial probabilities of realization. For the project selection problems authors suggest application of the Analytic Network Process, the approach which enables the development of models with network structures, in which the elements' interdependence present.

*Keywords: Project selection, rail projects, multicriterial decision making method, analytic network process*

### 1 Introduction

Models for selection and ranking railway infrastructure projects are very complex due to various relevant criteria, numerous external factors, and several stakeholders with different preferences, huge financial resources needed for investment and limited budget.

Considering external factors, especially important are relevant exterior projects. These projects can be: national or domestic projects, infrastructure projects, social or ecological projects, etc. It's possible to define different relevance of these projects on the projects for ranking. Choosing the relevant exterior projects should be done by company management or by experts.

For considered rail network in Serbia, one of the relevant exterior projects is the forthcoming privatization and improvement of the Port of Bar. Realization of this project would increase the volume of freight transport from Montenegro, through Serbia, to Hungary.

Railway infrastructure projects are important for economical and social development of a country. They also influence on strengthen the competitiveness of railways in the transport market.

Rail network in Serbia was developed in 1884. More than 55% of the rail lines were constructed in the 19<sup>th</sup> century. Mostly current allowed rail speed has been significantly decreased. Average permissible speed on the Corridor 10 is about 82 km/h, but the average speed of

the fastest trains is some over 60 km/h. There is huge difference between design and current train speed for the more than 90% rail lines in Serbia. On Corridor 10, which should be the best maintained part of the network, designed speed differs from the current speed for 15 and 40%. All these parts of the rail network can be considered as bottlenecks. Analyzing current conditions of the network and defining the priority sections, the importance of the infrastructure projects is obviously. Rail Corridor 10 from the north by north westerly to south by south easterly running TEN corridor x (Salzburg–Ljubljana–Zagreb–)Šid–Belgrade–Niš–Preševo (–Skopje–Veles–Thessaloniki) with branches over Subotica on the Hungarian and Dimitrovgrad on the Bulgarian border, presents the backbone of the Serbian rail network. Together, this represents a length of 872 km.

Project selection can be done before or after project ranking, like in this paper. Project selection is especially important in condition with constrained financial budget. The adequate project selection influences on the efficiency of using available equipment, financial and human resources. Choosing the method for project selection should be in accordance with: company strategy, available information (for instance, after defining the relevant criteria some needed data may be missed, so their values can be assumption), available time period for decision making, and amount of funds which will be dedicated to investment plan.

## 2 Brief literature review

According to literature [1], Cost–benefit analysis, CBA, is the most used approach for evaluation of transport projects in Europe. However, by reviewing the relevant literature from the last decade, which critically compares the CBA, as a single–criteria approach, with multicriteria decision making methods, MCDM, general conclusion is that modern characteristics of the evaluation transport projects require multicriterial approach. For instance, by opening the market, numerous stakeholders become interested for transport infrastructure projects. By applying the MCDM, many costs can be presented in original form; in practice usually it's very difficult to monetize them.

### 2.1 Transport projects' selection

Wey and Wu (2007) suggested an integrated approach for the problem of transport infrastructure projects selection [2]. They used: fuzzy Delphi, ANP and zero–one goal programming methods. In order to overcome some shortcoming of goal programming, the ANP approach is applied in this paper. The ANP takes into consideration the interdependent relations among the system's elements. Transportation projects in Taiwan were considered as the alternatives in the developed model.

Tudela, Akiki and Cisternas (2006) applied 2 approaches for transport project selection [3]. The authors compared the output of CBA and AHP approach. The obtained results were not the same but decision makers choose the suggestion of the AHP approach. Although CBA has been widely used for the transport project selection, there are some constrains of this method. Noise, accidents and air pollution are just some of the project impacts which is very difficult to include into CBA.

Piantanakulchai (2005) applied the ANP with the aim to deal with interdependent relationship within the multi–objective and multi–stakeholders in environment [4]. The goal of developed model was the selection of the highway corridor in Thailand. Considered criteria were: economic, engineering and construction, traffic and transportation, environment, land use and social.

Shang, Tjader and Ding (2004) compared the AHP and ANP approach for the transport project selection [5]. The decision makers chose the ANP for developing the model for transport project selection on one of China's oldest cities. Defined relevant criteria were: benefits, opportunities, costs and risks. In this paper, it's emphasized that ANP approach is better than

conventional evaluation methods as it allows feedback and interdependence among various decision levels and criteria. The authors mentioned a limitation of the proposed approach, i.e. when the model is large, it is time-consuming.

Yedla and Shrestha (2003) developed a model for transport project selection. Considered relevant criteria were: potential energy saving, potential reduction of emissions, cost, and availability of technology, adaptability of options and difficulties of implementation. The model includes environmental experts, energy experts, users and government, car associations, car research centers, and local agencies for implementation [6].

Ferrari (2003) suggested the AHP approach for transport project selection, and emphasized that the projects' attributes are their impacts, which should be considered from the point of view of the stakeholders [7].

## 2.2 Railway projects' selection

Chang, Wey and Tseng (2009) developed the model for the revitalization project selection relating to the Alishan Forest Railway in Taiwan [8]. The relevant criteria were: benefits, opportunities, costs and risks. The considered problem has been solved by fuzzy Delphi, ANP approach and zero-one goal programming.

Longo et al. (2009) developed models using AHP and ANP approaches. The case study was a rail infrastructure, the selection among the potential options regarding a new railway connection [9]. The authors considered following criteria: costs (project costs), transportation efficiency (safety, running efficiency – capacity and reliability), environmental impacts (natural, physical and urban resources) and procedural aspects (modification of the original project and interferences on the existing network). The obtained results were the same. The ANP approach allows taking into account the interdependences of the elements of the upper level – criteria, from the lower level elements – alternatives. The ANP is quite more complex to apply; the analysis of the problem has to be much more detailed compared to the requirements of the AHP approach. This makes the practical application of the ANP approach more problematic. However, AHP framework is often very rigid, and not flexible enough to describe in detail the decision makers' opinions.

Gercek, Karpak and Kilincaslan (2004) analyzed the alternatives for rail transit network in Istanbul [10]. The developed model used the AHP approach. The decision makers made a new option by combining the two similar alternatives for rail transit network. The sensitive analysis has been done, based on different criteria weight, which is very important for decision making process.

## 3 Model for rail projects' selection

This section presents the methodology of project selection using the ANP approach [11]. The projects of PE 'Serbian Railways' are alternatives in developed model. The projects include doubling rail trucks of rail Corridor 10 through Serbia (figure 1). The aim of the model is the project selection (table 1), i.e. allocation of the financial resources, based on the total contribution of the projects to the company goals and objectives. The degree of effectiveness for each project should be calculated.

Model is developed by applying the commercial client-oriented software 'SuperDecisions'. The relevant criteria are named in table 2; their relations are presented in table 3, whereby mark '=' shows the direction of the influence.

Software 'SuperDecisions' calculates the total performance of one project presenting the project contribution to company's objectives and goals. Maximal value is '1', which describes an ideal project according to all relevant criteria. All these values of projects' performances should be transferred to Excel. The first column of this table presents the projects, thereafter the performances calculated by the ANP approach, and in the third column total projects'





**Table 1** Considered alternatives.

No.	Alternative	
1	D <sub>1</sub>	Subotica – Stara Pazova
2	D <sub>2</sub>	Resnik – Mladenovac – Velika Plana
3	D <sub>3</sub>	Stalač – Đunis
4	D <sub>4</sub>	Resnik – Mali Požarevac – Velika Plana
5	D <sub>5</sub>	Niš – Preševo
6	D <sub>6</sub>	Niš – Dimitrovgrad

**Table 2** Relevant criteria.

No.	Criteria	
1	C <sub>1</sub>	Average revenue per train [€]
2	C <sub>2</sub>	Criteria of speed restriction – travel time lost [train hours/km]
3	C <sub>3</sub>	Criteria of traffic volume [train/day]
4	C <sub>4</sub>	Criteria of rail infrastructure capacity utilization – the percent of rail line capacity utilization [%]
5	C <sub>5</sub>	Exterior projects

**Table 3** Criteria cross-impact.

	C <sub>1</sub>	C <sub>2</sub>	C <sub>3</sub>	C <sub>4</sub>	C <sub>5</sub>
C <sub>1</sub>	/				
C <sub>2</sub>	↑	/	↑	↑	↑
C <sub>3</sub>	↑	↑	/	↑	↑
C <sub>4</sub>		↑	↑	/	
C <sub>5</sub>	↑		↑		/

**Table 4** Final results of considered model for rail project selection

	Total (from ANP ratings)	Cost/Project (in '000's)	Effectiveness (Normalized)*100	Decision variable	Cost (in '000's)	Performance (effectiveness)
D <sub>1</sub>	0.593	125	60	1	125	60
D <sub>2</sub>	0.956	519	100	1	519	100
D <sub>3</sub>	0.501	620	52	1	620	52
D <sub>4</sub>	0.306	886	32	0	0	0
D <sub>5</sub>	0.317	670	33	1	670	33
D <sub>6</sub>	0.296	750	31	0	0	0
				Total	1934	248
						Performance score
				Available	2500,000	

## 4 Conclusions

The problem of selection and prioritization transport infrastructure projects is the crucial issue for all transport networks worldwide. The model of rail infrastructure projects is complex due to many various relevant criteria, numerous stakeholders and limited financial budget.

This paper presents the model for rail infrastructure project selection using the ANP approach. Developed model considered the single rail trucks of Corridor 10 through Serbia. Using the multicriterial approach, the ANP, the sections of this network were ranked based on relevant criteria.

## References

- [1] <http://heatco.ier.uni-stuttgart.de/hd1final.pdf>
- [2] Wey, W-M., Wu, K-Y.: Using ANP priorities with goal programming in resource allocation in transportation, *Mathematical and Computer Modeling*, 46, pp. 985-1000, 2007.
- [3] Tudela, A., Akiki, N., Cisternas, R.: Comparing the output of cost benefit and multi-criteria analysis. An application to urban transport investments, *Transportation Research Part A*, 40, pp. 414-423, 2006.
- [4] Piantanakulchai, M.: Analytic network process model for highway corridor planning, *ISAHP*, Honolulu, Hawaii, 2005.
- [5] Shang, J. S., Tjader, Y., Ding, Y.: A unified framework for multicriteria evaluation of transportation projects, *IEEE Transactions on Engineering Management*, Vol. 51, No. 3, pp. 300-313, 2004.
- [6] Yedla, S., Shrestha, R.: Multi-criteria approach for the selection of alternative options for environmentally sustainable transport system in Delhi, *Transportation Research Part A*, 37, pp. 717-729, 2003.
- [7] Ferrari, P.: A method for choosing from among alternative transportation projects, *European Journal of Operational Research*, 150, pp. 194-203, 2003.
- [8] Chang, Y-H., Wey, W-M., Tseng, H-Y.: Using ANP priorities with goal programming for revitalization strategies in historic transport: A case study of the Alishan Forest Railway, *Expert Systems with Applications*, 36 (4), pp. 8682-8690, 2009.
- [9] Longo, G., Padoano, E., Rosato, P., Strami, S.: Considerations on the application of AHP/ANP methodologies to decisions concerning a railway infrastructure, *Proceedings of the International Symposium on the AHP*, 2009.
- [10] Gercek, H., Karpak, B., Kilincaslan, T.: A multiple criteria approach for the evaluation of the rail transit networks in Istanbul, *Transport Journal*, 31, pp.203-228, 2004.
- [11] Saaty, Th. L.: *Decision making with dependence and feedback: The Analytic Network Process*, RWS Publications, Pittsburgh, 1996.

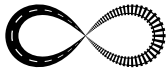

## APPLICATION OF MULTICRITERIA OPTIMIZATION IN THE RAILWAY LINE DESIGNING AT THE GENERAL PROJECT LEVEL

Ljubo Marković<sup>1</sup>, Ljiljana Milić Marković<sup>2</sup>, Goran Ćirović<sup>3</sup>

<sup>1</sup> Faculty of Technical Sciences in Kosovska Mitrovica, Serbia

<sup>2</sup> CIP Traffic Engineering Institute, Serbia

<sup>3</sup> College of Civil Engineering and Geodesy in Belgrade, Serbia

### Abstract

This paper presents the application of multicriteria optimization procedure in choosing the most favourable variant solutions of the route for the requirements of the General project of reconstruction and modernization of Belgrade–Niš railway line, at the Stalać (Ćičevac)–Djunis section – in other words, the method of multicriteria compromise ranking of variant solutions, with the following basic activities: variant solutions have been defined, the evaluation of variant solutions made and the decision reached on the most favourable solution.

*Keywords: variant solutions, ranking, multicriteria optimization, optimum solution, compromise ranking*

### 1 Introduction

Creating railway line design solutions represents conceiving real corridors – routes, and is based on demand balancing (in other words, traffic demands), goals and limitations, on the one hand and supply expressed in the existence of realistic solutions, on the other hand. This balancing is realized through corresponding design solutions on appropriate foundations. The evaluation of railway line design solutions means a procedure of evaluation and decision-making, including the procedures of defining indicators and criteria relevant for evaluation and decision-making in the course of creation of optimum development and use. The evaluation is carried out after, and in the course of each stage of the project – from creating basic ideas all the way through to the main and execution design. Designing railway lines represents an iterative process of solutions optimization according to a series of criteria which, in its final stage, leads to the most favourable solution. In this way, the evaluation is integrated into the process of designing variant solutions, since their essential tasks, goals and meaning are identical.

### 2 Multicriteria compromise ranking of alternative solutions

Multicriteria optimum solution is obtained by multicriteria optimization, which is for discreet systems carried out by means of multicriteria ranking of alternatives and choosing an optimum solution. Multicriteria optimization is carried out in several stages as follows: designing of variant solutions, defining criteria and criteria functions for evaluation of variant solutions, evaluation of all variant solutions according to each criterion respectively, multicriteria ranking of variant solutions and adoption of the most favourable solution.

The condition which should be fulfilled is that all alternatives be evaluated according to all criteria. For multicriteria compromise ranking of alternative solutions, the following is valid:

· alternative  $a_j$  is better than alternative  $a_k$  according to  $i$  criterion if:

$$f_{ij} > f_{ik} \tag{1}$$

· alternative  $a_j$  is better than alternative  $a_k$  according to all criteria if:

$$D(f_1(a_j), \dots, f_n(a_j)) < D(f_1(a_k), \dots, f_n(a_k)) \tag{2}$$

where  $D(f_1, \dots, f_n)$  is a resultant of the function which represents the measure of aberration from the reference point.

### 2.1 VIKOR method

VIKOR method (VIšekriterijumsko Kompromisno Rešenje – Multicriteria compromise solution) complete with programme package (VIKOR) solves optimization tasks with many heterogeneous and conflicting criteria. The solution obtained can be either unique or it can represent a set of close solutions. The compromise solution is that permissible solution which is closest to the ideal one. The ideal solution is determined based on the best values of criteria and is not usually a part of the given set of alternative solutions.

#### 2.1.1 VIKOR method operating algorithm

It is necessary to rank alternative solutions  $a_1, a_2, \dots, a_j$  with the set values of criteria functions  $f_{ij}$ ,  $i=1, n$  and  $j=1, J$ , where  $n$  is the number of criteria and  $J$  is the number of alternatives. The ranking procedure goes as follows:

a The best  $f_i^*$  and the worst  $f_i^-$  values for all  $i=1, 2, \dots, n$  criteria functions are determined;

$$f_i^* = \max_j f_{ij}, f_i^- = \min_j f_{ij}, \text{ if } i\text{-th function represents a gain,} \tag{3}$$

$$f_i^* = \min_j f_{ij}, f_i^- = \max_j f_{ij}, \text{ if } i\text{-th function represents the costs} \tag{4}$$

b Based on  $S_j$  and  $R_j$  measures, the alternative solutions are ranked and the position of  $a_j$  on  $s(a_j)$  and  $r(a_j)$ , ranking lists are determined, whereas  $s(a_j)$  and  $r(a_j)$ ,  $j=1, 2, \dots, J$  values are calculated using the following relations:

$$S_j = \sum_{i=1}^n \omega_i (f_i^* - f_{ij}) / (f_i^* - f_i^-), \text{ (for } p=1) \tag{5}$$

$$R_j = \max_i \omega_i (f_i^* - f_{ij}) / (f_i^* - f_i^-), \text{ (for } p=\infty) \tag{6}$$

where:  $n$  – is the number of criteria,  $\omega_i$  – is the weight of  $i$ -th criterion and expresses the preference of a decision-maker, i.e. relative importance of a criterion,  $S_j$  – is a measure of distance  $R(F, 1)$  from an ideal point for alternative  $j$  and  $R_i$  – measure of distance  $R(F, \infty)$  from ideal point for alternative  $j$ . Ranking, according to  $S_j$  and  $R_j$  measures, results in two ranking lists of alternatives. In order to obtain an integrated ranking list, compromise programming is applied according to which  $S_j$  and  $R_j$  are now criterion functions. The new ranking measure is:

$$Q_j = vQS_j + (1-v)QR_j = v \frac{S_j - S^*}{S^- - S^*} + (1-v) \frac{R_j - R^*}{R^- - R^*} \tag{7}$$

where:

$$S^- = \max_j S_j \quad \text{and} \quad R^- = \max_j R_j \quad (8)$$

$$v = (n + 1) / 2n - \text{difficulty of group benefit decision making strategy} \quad (9)$$

$$(1 - v) - \text{difficulty of individual dissatisfaction} \quad (10)$$

$QS_j$  and  $QR_j$  represent normalized values. From the multicriteria point of view, alternative  $a_j$  is better than alternative  $a_k$ , if  $Q_j < Q_k$  and is ranked higher on the list.

c VIKOR method suggests, as the best alternative from the multicriteria point of view, the one which is at the first place of the compromise ranking list for  $v=0.5$  only if it holds:

- (C1) – 'sufficient advantage' over the alternative from the next positions. The difference between  $Q_j$  measures is used for evaluation of the 'advantage'. Alternative  $a'$  has a sufficient advantage over the next position on the ranking list  $a''$  if:

$$Q(a'') - Q(a') \geq DQ \quad (11)$$

where  $DQ$  is 'the threshold of advantage':  $DQ = \min(0.25; 1/(j-1))$ . The threshold for cases with small number of alternatives is limited by 0.25

- (C2) - 'sufficiently stable' first position with the change of difficulty  $v$  (for  $v=0.25$  and  $v=0.75$ ).  $a'$  alternative must also be ranked by  $QS$  and/or  $QR$ .

If some of the conditions are not fulfilled, a set of compromise solutions is formed which includes the first alternative and the next following it. If the first alternative does not fulfil only the condition (C2), then the set of compromise solutions includes only the second one from the compromise ranking list. If it does not fulfil the condition (C1), then the set of compromise solutions contains alternatives from compromise ranking list up to the one which fulfils the condition that the first alternative does not have sufficient advantage over that particular alternative. The results of the VIKOR method are ranking lists according to measures  $QR$ ,  $Q$  (for  $v = 0.5$ ) and  $QS$  and a compromise alternative or a set of compromise solutions. These results represent a basis for decision-making and adoption of the most favourable (multicriteria optimum) solution.

### 3 Example

For the purpose of the General project of reconstruction and modernization of the railway line at Corridor 10 (Belgrade–Niš railway line, Stalać (Ćićevac)–Djunis section), it is necessary to evaluate the suggested variant solutions using the VIKOR method and to determine the most favourable variant solution.

#### 3.1 Defining variant solutions

Belgrade–Niš railway line (240.8 km) represents an important part of Corridor 10 from both the national and international aspect. The function and technical parameters of the railway line do not meet the requirements of a contemporary railway line. Twin rail tracks are in length of 128.3 km and the single track is 112.5 km long. The project provides for the twin rail track to be constructed along the entire length from Belgrade to Niš. As Stalać–Djunis section is a single-track passing through the Južna Morava river valley, with sharp curves with minimum radius of  $R=300\text{m}$  and transition curves  $L=22\text{ m}$ , which enable the speed of 65 km/h, there are four variant solutions suggested (Figure 1).

### 3.1.1 Variant solution 1 – for the speed up to 100 km/h

The elements of the site plan  $R_{\min}=500\text{m}$  with transition curve  $L=140\text{m}$  are adopted for this solution. Variant solution follows the route of the existing railway line, uses the bridge built for the second track over the Južna Morava river and provides for the construction of two tunnels  $L_1=465\text{m}$  and  $L_2=750\text{m}$  long respectively. The route length according to this variant solution is 18 km, with maximum designed longitudinal inclination of 5.5 ‰.

### 3.1.2 Variant solution 2 – for the speed up to 120 km/h

The adopted elements of the site plan are  $R_{\min}=700\text{m}$  with transition curve  $L=180\text{m}$ . Because of the more comfort elements of this site plan, the variant solution varies more from the existing railway line route. There are three tunnels designed  $L_1=350\text{m}$ ,  $L_2=570\text{m}$  and  $L_3=710\text{m}$  long respectively. This variant too, where the route is 17.5km long, with designed longitudinal inclination of 6.0‰ uses the already existing bridge for the second track over the Južna Morava river.

### 3.1.3 Variant solution 3 – for the speed up to 160 km/h

The design elements of the site plan route are:  $R_{\min}=1500\text{m}$  with transition curve  $L=180\text{m}$ . At the beginning, from the station in Stalać, the variant solution follows the route of the existing railway track up to km 178+000, and the remaining part includes the construction of the new railway track all the way to Djunis. The length of tunnels designed according to this variant solutions is  $L_1=1100\text{m}$ ,  $L_2=570\text{m}$ ,  $L_3=390\text{m}$ ,  $L_4=3020\text{m}$  and  $L_5=540\text{m}$  respectively. It is required to build a new twin rail track bridge  $L=156\text{m}$  over the Južna Morava river and secure the river bed at three places. The highest designed longitudinal inclination according to this variant is 3.8 ‰, and the route is 13.40 km long.

### 3.1.4 Variant solution 4 – for the speed up to 200 km/h

As distinguished from the previous solutions, this variant solution provides for the construction of new railway line route which starts from the station in Čičevac and fits into the existing railway line at km 189+000. The route elements  $R_{\min}=3000\text{m}$  with transition curve  $L=180\text{m}$  provide for the speed up to 200 km/h. Along this 16.4 km long route, there are tunnels designed  $L_1=4\,630\text{m}$ ,  $L_2=1\,355\text{m}$  and  $L_3=805\text{m}$  long respectively as well as a bridge over the Južna Morava which is 156m long. At the part of the route within the bridge zone the regulation of the Južna Morava river bed is required.



Figure 1 Variant solutions of Stalać (Čičevac) – Dunis section

### 3.2 Defining goals and criteria

The following goals have been defined: minimum construction costs (construction and electrical–technical infrastructure, expropriation, and other), minimum maintenance costs (regular and investment maintenance of superstructure and foundation, electrical engineering facilities and units, buildings and other), maximum benefit for railway line users (train–handling capacity of the track section, passenger train journey time in international traffic), minimum effects on location development (fitting into directions of development of network and other traffic systems as well as territorial spreading) and minimum effect on the environment (noise, vibrations, water pollution, soil pollution and degradation, territorial spreading, flora and fauna, micro climate and visual pollution). The pattern of relative goal difficulties resulted from the use of simplified Delphi method at the sample of 30 respondents, who analyzed the importance of each criterion taking into account both general knowledge and specific conditions of the location. The results of the statistic processing – relative goal difficulty ( $\hat{w}$ ), standard deviation ( $s$ ) and variation coefficient ( $v$ ) are shown in Table 1.

The tabular statement of defined goals, criteria, indicators and their relative difficulties for variant solutions is shown in Table 5. Based on the chosen goals, criteria and the relations of their difficulties, the first ranking of variant solutions was made. The results obtained are shown in Table 2.

After the ranking, a set of variant solutions was obtained as a compromise solution for final decision which includes the variant solutions for  $V_r=120\text{km/h}$ ,  $V_r=160\text{ km/h}$  and  $V_r=100\text{km/h}$  as well as the advantages of the given solutions when compared with other options. Variant solution  $V_r=200\text{km/h}$  is not included in the set of compromise solutions and it was rejected as uneconomical. Compromise solution for the final decision makes the set which comprises the solutions within  $WD_1 \leq w \leq WG_1$  difficulty interval, while for the interval  $WD(i) \leq w \leq WG(i)$  these solutions will be a part of compromise set of 'S' variant solutions. 'S' value is read off the right side of Table 4. FAC is the factor of increase (right) or decrease (left FAC) of input value of difficulty in order to obtain a different compromise solution. 888.8 value is marked as  $\infty$ , for  $WG(i)=1.000$ .

The previous ranking gives precedence to economic goals. Taking into account the recommendations of the European Parliament and the EU Directive on environmental liability and elimination of harmful effects of the occurred environmental damage according to 'polluter–pays' principle, the second ranking gives precedence to the goal – Minimum effects on the environment in comparison with other goals and new relations among the difficulty criteria were set (trade–off). The result obtained by this ranking is a set of variant solutions which comprises the variant solution  $V_r=160\text{km/h}$  and the variant solution  $V_r=120\text{km/h}$ , whereas the variant solution  $V_r=160\text{km/h}$  is given preference of 11.5%. The results obtained by second ranking are shown in Table 3.

**Table 1** The results obtained using Delphi method

1	Max. benefit for the railway line users	29.7	7.9	0.266	0.297
2	Min. investment costs	22.1	8.8	0.398	0.221
3	Min. maintenance costs	19.2	4.8	0.250	0.192
4	Min. effects on location development	14.5	5.3	0.366	0.145
5	Min. effects on the environmental development	14.5	7.8	0.538	0.145



**Table 2** The first ranking of variant solutions

Ranking list of variant solutions	Compromise solution for final decision	
1 0.147 Vr=120km/h	Set of alternatives	Advantage
2 0.151 Vr=160km/h	A2. Vr=120km/h	0.4%
3 0.337 Vr=100km/h	A3. Vr=160km/h	18.6%
4 1.000 Vr=200km/h	A4. Vr=200km/h	

**Table 3** Second ranking of variant solutions

Ranking list of variant solutions	Compromise solution for final decision	
1 0.151 Vr=160km/h	Set of alternatives	Advantage
2 0.266 Vr=120km/h	A3. Vr=160km/h	11.5%
3 0.463 Vr=100km/h	A2. Vr=120km/h	
4 1.000 Vr=200km/h		

**Table 4** The pattern of goals, criteria and indicators with their relative difficulties and values of criteria functions

Goal	Criteria	Indicators	Scale	Type	Weight	Relative difficulties				Values of criteria functions			
						1	2	3	4	1	2	3	4
Increase the number of passenger trains	Number of passenger trains	Number of passenger trains	Number of passenger trains	Number of passenger trains	Number of passenger trains	1	2	3	4	1	2	3	4
						1	2	3	4	1	2	3	4
Increase the number of freight trains	Number of freight trains	Number of freight trains	Number of freight trains	Number of freight trains	Number of freight trains	1	2	3	4	1	2	3	4
						1	2	3	4	1	2	3	4
Increase the number of high-speed trains	Number of high-speed trains	Number of high-speed trains	Number of high-speed trains	Number of high-speed trains	Number of high-speed trains	1	2	3	4	1	2	3	4
						1	2	3	4	1	2	3	4
Increase the number of international trains	Number of international trains	Number of international trains	Number of international trains	Number of international trains	Number of international trains	1	2	3	4	1	2	3	4
						1	2	3	4	1	2	3	4
Increase the number of international freight trains	Number of international freight trains	Number of international freight trains	Number of international freight trains	Number of international freight trains	Number of international freight trains	1	2	3	4	1	2	3	4
						1	2	3	4	1	2	3	4
Increase the number of international high-speed trains	Number of international high-speed trains	Number of international high-speed trains	Number of international high-speed trains	Number of international high-speed trains	Number of international high-speed trains	1	2	3	4	1	2	3	4
						1	2	3	4	1	2	3	4

Table 5 Analysis of preference stability – Difficulty intervals for individual criteria

	F <sub>10</sub> S	F <sub>10</sub> S	G <sub>10</sub> S	G <sub>01</sub> S	G <sub>01</sub> S	G <sub>01</sub> S	G <sub>01</sub> S	F <sub>10</sub> S
F 1	3	0.272	0.220	0.276	0.261	0.226	0.272	3.6
F 2	3	0.167	0.159	0.194	0.192	0.171	0.169	2.0
F 3	4	0.026	0.026	0.027	0.049	0.134	0.154	1.0
F 4	2	0.517	0.482	0.532	0.492	0.482	0.443	1.0
F 5	3	0.620	0.628	0.624	0.632	0.635	0.615	1.0
F 6	2	0.066	0.058	0.056	0.073	0.076	0.074	1.0
F 7	3	0.028	0.028	0.051	0.035	0.039	0.037	1.1
F 8	3	0.168	0.141	0.182	0.177	0.165	0.120	1.2
F 9	3	0.580	0.636	0.556	0.522	0.704	0.624	1.3
F 10	3	0.734	0.617	0.657	0.623	0.472	0.482	2.0
F 11	3	0.636	0.621	0.528	0.569	0.619	0.613	1.4
F 12	3	0.431	0.610	0.609	0.514	0.405	0.362	2.0

## 4 Conclusion

Optimization of complex systems such as traffic system represents a process in which both theoretical knowledge and experiences of the experts from several disciplines are united. It is of essence to consider the goals, to set boundaries, to divide entities and to establish interactions, to determine necessary resources and to provide for the optimum functioning and use of the system. This imposes the need for the optimization to be made according to the criteria which will take into account all major components or consequences of the system development. This paper has presented the use of the VIKOR method. It has presented the set list of goals and criteria, as well as the manner of determining their relative difficulties. Compromise ranking has been made based on which a set of alternative solutions has been obtained. The difficulty intervals have been set using trade-off (variation of mutual relations of goals and criteria) in which the variant solution can be stable, as well as a wider interval within which the first ranked variant solution remains within a compromise set of several variant solutions.

## Acknowledgements

The work reported in this paper is a part of the investigation within the research project TR 36017 supported by the Ministry for Science and Technology, Republic of Serbia. This support is gratefully acknowledged.

## References

- [1] Direktiva 2004/35/CE Evropskog Parlamenta i Saveta od aprila 2004 o odgovornosti za ekološku štetu u vezi sa zaštitom i otklanjanjem ekološke štete. OJ, L 143, 30. 4
- [2] Marković, Lj., Milić Marković, Lj.: Definisanje ciljeva i određivanje težina kriterijuma u postupku vrednovanja varijantnih rešenja primenom višekriterijumske optimizacije u procesu projektovanja saobraćajnica, SYM-OP-IS 2010 - xxxvii Simpozijum o operacionim istraživanjima, Tara, 2010.
- [3] Opricović, S., G.H. Tzeng: Extended VIKOR method in comparison with outranking, European Journal of Operational Research 178, No.2, pp. 514-529, 2007.
- [4] Saobraćajni institut CIP - Generalni projekat rekonstrukcije i modernizacije železničke pruge Beograd - Niš, Beograd, 2007.



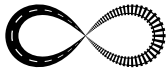

## BENEFITS OF A MANAGED ENVIRONMENT ON A LARGE INFRASTRUCTURE PROJECT

Silvano Paolo Gritti, Andrea Amante, Armando Manes  
*Società di Progetto Brebemi SpA, Italia*

### Abstract

The new Brescia–Bergamo–Milan Motorway Connection, commonly known as Brebemi, is the new toll motorway linking the city of Brescia with Milan. The overall project will provide the completion of the new 3 lane motorway in each direction, approx. 62 km long, along with new local roads and the renovation of existing roads in the length of 35 km or so. The route involves 43 municipalities and 5 provinces and the total cost of the work is 1.6 billion euros. The Company has decided to implement a solution to manage all documentation, at any level, connected with the Project and has chosen Bentley ProjectWise as a solution which meets all the requirements. During its implementation, an appropriate environment has been created for every work area, the file management procedures have been published and the access profiles and approval cycles have been created.

Now all of the documentation of the final and executive plan (consisting of around 60,000 technical drawings in editable and PDF format) which has been drawn up by the various external design units located all over Italy, under the coordination of the General Contractor which will also be responsible for the construction of the motorway, exist on a centralised server at the Brescia office. All procedure and authorisation documents for the project are also filed, as well as all correspondence.

The main benefits of implementing a managed environment solution include time saving in communication, controlled and accessible presentation of design and procedure documents, better standardisation of drawings and texts and the definition and implementation of linear workflows and verification.

*Keywords: managed environment, Bentley ProjectWise, project design*

### 1 Introduction

The construction of a motorway infrastructure necessarily involves the execution of many complex activities (planning, design, construction, inspection, approval and management), in which many stakeholders are involved (Grantor, Concessionaire, General Contractor, Design Teams, Public and Private Institutions, Surveillance Authorities, etc..) disseminated throughout the country, thus creating a large number of interactions and relationships which materialize in the drafting of documents in various forms (project drawings, reports, inquiries, authorizations, ordinary correspondence, etc); the number of documents can be in the range of hundreds of thousands.

Brebemi SpA, which holds the concession for the design, implementation and management of the new motorway to be built between the cities of Brescia and Milan, has addressed this issue by identifying the need to equip itself with adequate software tools enabling the effective management of all the produced documentation: Bentley ProjectWise is the software product the Company has decided to use.

## 2 How Brebemi fits in the infrastructural framework of Lombardy

Infrastructures and mobility management are certainly a priority for Lombardy. In this context, the new Brescia–Bergamo–Milano motorway link, known as Brebemi, is a response to the many needs of the Lombardy population, with the goal of freeing the existing road network and motorway corridor Milan–Bergamo–Brescia from traffic congestions. The new link will allow fast and safe travels on a road system that is fully integrated into the new Lombardy infrastructural system, decongesting the existing road network and the motorway corridor Milan–Bergamo–Brescia.

Brebemi will be able to attract a significant portion of the long-distance traffic that currently uses the A4, most of the short–medium distance traffic, and particularly trucks and commercial vehicles, which now congest ordinary roads all around small towns of the plain stretching between Bergamo and Brescia. Traffic forecasts show that the new motorway will be used, on average along the entire axis, by daily traffic flows of 40,000 vehicles in the first months, and by 60,000 vehicles when the motorway will be fully operational. The increased motorway capacity will free local road networks, avoiding congestions and inefficiencies. The opening to traffic of Brebemi will allow local governments to apply policies in order to control and reduce access to urban centres, especially trucks, with benefits in terms of reduced air pollution and noise, and improved quality of life for residents. The total cost of the Brebemi project is 1.6 billion euros without contributions from the Central Government. The entire budget will be financed exclusively with funds of the licensed company and by resorting to borrowing. Thus this motorway becomes an innovative project, also from a financial standpoint. Brebemi is the first Italian motorway entirely funded through the use of project finance, and it is one of the most important and complex operations currently being developed in Europe.

## 3 Brief description of the Project

The overall project envisages the construction of a new dual carriageway, 3 lanes each, about 62 km long; its path runs through the heart of the Pianura Padana, in the Lombardy Region, encompassing 43 municipalities and 5 provinces; along its axis there are 2 toll barriers and 6 toll stations, the main engineering works are the viaducts on Oglio (690 m), Serio (930 m) and Adda (1260 m) rivers, and the Treviglio artificial tunnel (465m in groundwater). Four service areas, a maintenance centre and an operations centre, all facilities required for management and user services, will be built along its length. The motorway will be built according to high level manufacturing standards, with equipment designed to improve users' safety and to increase the performances of individual components in order to reduce maintenance interventions during operation, with consequent reduction of road works and increased motorway safety.

Besides the construction of the motorway, the project includes 17.5 km of road connections to improve access to the cities of Brescia and Milan, and 17 km of road network to improve the local road network in the vicinity of the motorway. A general overview of the operation is shown in Figure 1.



Figure 1 Brebemi highway within the Lombardy infrastructural system

Stakeholders of the project are:

- GRANTOR AGENCY: Concessioni Autostradali Lombarde SpA - CAL SpA;
- CONCESSIONAIRE: Società di Progetto Brebemi SpA, controlled by AUTOSTRADE LOMBARDE SpA;
- GENERAL CONTRACTOR: Consorzio BVM, composed of Pizzarotti SpA and ccc (Consorzio Cooperative Costruzioni) construction companies;
- WORKS MANAGEMENT: Pegaso Ingegneria.;
- HIGH SURVEILLANCE OF CONCESSIONAIRE: Metro Engineering. (Company owned 100% by Metropolitana Milanese SpA);

Works began on July 22nd 2009 on the site of the Oglio viaduct; on January 31st 2012 the overall progress of works is at 33%, while the most complex works, Oglio, Serio and Adda viaducts are respectively at 95%, 50% and 52% completion.

#### 4 Brebemi & Bentley ProjectWise

From the early stages of the project development, the Company has aimed at the implementation of a system capable of handling all documentation (design documents, reports, permits, construction documents, correspondence, meeting minutes of all companies of the group) in an electronic form, based in its office in Brescia. Through a local network or via Web, the system must be able to uniquely identify the current version of each document, as well as its history, including all the obligations arising under the Convention granted to the Company. All accesses must be fully controlled and tracked.

As of today, environments necessary to support all activities required to create such a large road work were created in ProjectWise; in the design phase the system handles all files related to the final project, its changes during the construction phase, and all the detailed designs (necessary for the development of special and unique elements, such as the individual segments of the 3 viaducts) in addition to the As Built drawings. Records related to expropriation of land property, management and resolution of technological interferences that had to be removed are handled and stored in ProjectWise. And, last but not least, all documents recording sites operations are processed in ProjectWise: these documents include quality management, financial reports, reporting on the progress of construction, materials for the Commission of Inspection. All uploading procedures and approval processes are standar-

dized and shared with all the parties involved at all levels of the project, from technicians working on site to the Public Authorities represented by the Grantor.

Each environment is characterized by a proper and specific data storage facility, by a specific approval cycle associated to documents, by an encoding scheme based on 32 digits which takes on different values and meanings in each environment, and by a specific access rights matrix permitting access to users' files, divided in groups.

## 5 Description of products & services

The system architecture includes a centralized server at the Brescia offices.

The following ProjectWise modules are installed on the server: Integration Server, the heart of the system's organization, management and sharing of data, and the Web Server for Web access.

Users access documents through the ProjectWise Explorer client, which allows access via a local Internet connection and, thanks to the Gateway Services, via the Web, or through Internet Explorer that, at first login, automatically uploads a plug-in for ProjectWise access. External users connecting from their offices or from remote sites, can also access the system through a gateway which handles communications to the DMZ2 network within which the ProjectWise server is protected by firewalls.

Brebemi's internal users access ProjectWise directly, without going through the gateway, but always through the firewall.

External access through the Internet, is supported by a bidirectional balanced communication line at 30Mbit/s (Fiber Channel line with 4 MBit/s SHDSL backup line).

The ProjectWise system is equipped with a synchronization mechanism, named Delta File Transfer, which permits to avoid the transfer of files on the network when the local copies and the centralized copies of the documents are aligned. Thanks to this mechanism, the average demand of communication bandwidth is relatively limited when compared to the number of users and to the size of the managed documents.

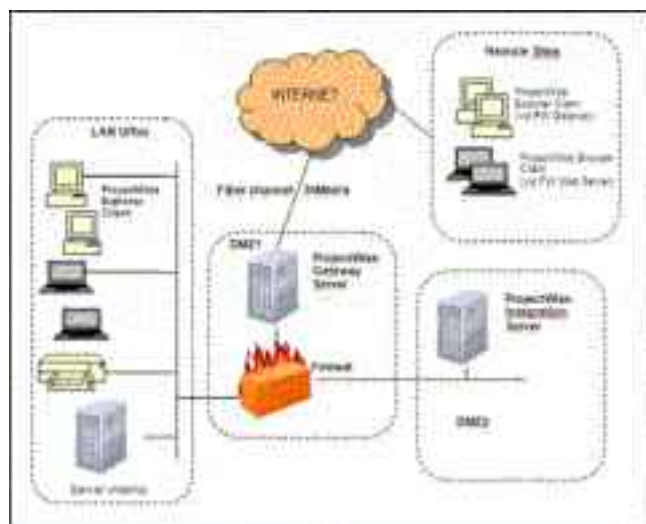

Figure 2 Graphic diagram of hardware configuration

## 6 Management of final design files

The final design of the new motorway link was the responsibility of BVM Consortium under a General Contractor contract of entrustment: numerous engineering companies disseminated throughout the country have contributed to the final design, all under the coordination of the BVM Consortium technical direction. The design, as a whole, includes about 1,000 engineering works, with a total of 25,000 documents: drawings, reports and spreadsheets.

The procedure to control each contractual document is governed by regulations, and it is implemented by the stakeholders of the project through a status change workflow for each document: each project document is generated by the designer in charge, approved by the Concessionaire through the Surveillance Authority, and approved by the Grantor; the final approval of the Construction Site Director validates the documents for construction, which are directly accessible from the local branches of operating sites.

### 6.1 Archive Structure

Drawings related to the final design are created by designers, directly in ProjectWise from their workstations; the entire motorway has been divided into lots and each lot into works. The archive structure replicates the WBS hierarchy.



Figure 3 Final Design environment structure

### 6.2 Coding Scheme for the Final Design

The ProjectWise coding system automatically assigns many of the 32 digit fields of the document code, according to where the document is created in the archive, so that the designer must only define the type of document he is creating by checking the appropriate code from a drop down list, while the remaining fields are automatically assigned. The code of a final design document can have the following values and meanings:



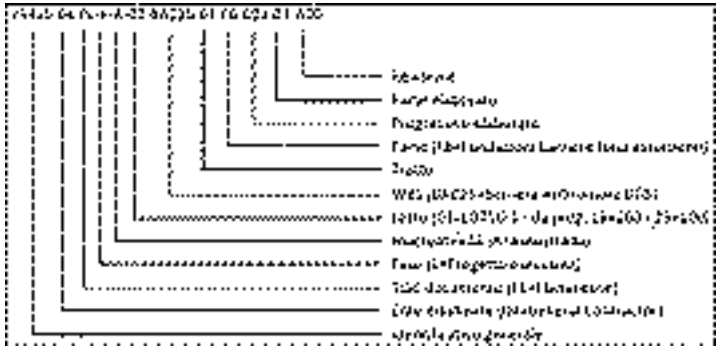

Figure 4 Coding convention for the final design

Besides the fields that make up the code, further attributes that the designer must enter when creating the document have been defined, for example the lines of the descriptive title of the document. These attributes, along with the code, are automatically written into the title block of drawings, thanks to the ProjectWise functionality which allows the linking of the ProjectWise attributes and the CAD title blocks fields.



Figure 5 Entry template for attributes

### 6.3 Workflow and status changes

The approval workflow of documents occurs in two distinct environments which have the same file structure as previously seen. The first, called the editable environment, contains the documents in native editable format on which the first stage of the approval process is executed. The second, called the non editable environment, contains documents in PDF format on which the second stage of the approval process is executed.

In ProjectWise, access rights to documents vary according to the status that the document takes on during its approval process, so you can make sure that people who must approve the documents receive access rights only when such documents have been submitted. Con-

versely, the person who submits a document for approval, at the time of submission loses the rights to modify the document.

Until a document is in the 'in progress' status, only the Project Manager may perform a status change. When the Project Manager moves the document into the 'DA APPROVARE SDP – TO BE APPROVE BY SDP' status, he and the designers have a read-only access to the document, so that designers can no longer modify the document waiting for approval.

In this way, ProjectWise guarantees that status changes are performed only by the proper persons at the proper time.

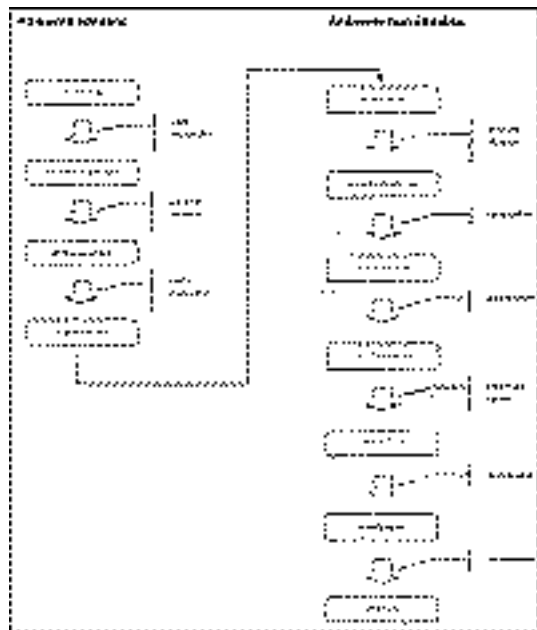

Figure 6 Approval workflow of the final design

The first part of the workflow involves the designers and the Concessionaire in an editable environment, to allow all the required modifications to the project before freezing it up and transferring it to the non editable pdf version in the non editable environment where the Grantor and the Construction Site Director approve and endorse the documents. Then an automatic ProjectWise procedure stamps them.

More specifically, the designer must prepare the documents in the Final Design folders using editable files and by exclusively using the following formats:

- 1 Drawings in DWG format;
- 2 X-REF file associated with drawings;
- 3 DOC format files.

Once a single document is complete, the design coordinator moves the document to the 'DA APPROVARE SDP - TO BE APPROVED BY SDP' status, and ProjectWise makes the document visible and ready to be checked by the High Surveillance of the Concessionaire; this status change involves the loss of designer's rights to modify the contents of the file; following all necessary checks, the Concessionaire places the document in the workflow to the APPROVATO SDP - APPROVED SDP status, and allows the High Surveillance to be in control of the document. At this point the document is frozen and transferred in the pdf format, by the designer, into the not editable environment (status GENERATED PDF); control passes on to the second part of the

approval workflow; the continuous automatic alignment of the two environments allows the transfer of the attributes (necessary for all selection and research operations) of the editable file to a non-editable file. High Surveillance verifies correspondence between the approved editable and the non-editable pdf copy, and, after approval (status DA APPROVARE CAL - TO BE APPROVED BY CAL) submits the document to the Grantor by moving the document to the next status (APPROVATO CAL - APPROVED BY CAL); at this point the document is endorsed by the Director of Works and made visible to the site (status STAMPABILE - PRINTABLE). Each status change requires the affixing of a watermark on the pdf file which records the status of the file; the stamping operation is made by a tool specifically developed by Bentley according to Brebemi's specifications.



Figure 7 Example of an approved document with watermarks

The release of a possible review of a document, as a result of a change to the project, involves the switching of the obsolete files to SUPERATO - OBSOLETE status, with automatic stamping of a well visible graphic warning on the title block of the drawing.

#### 6.4 Use of Flat Set

The flat-Set ProjectWise tool has been conveniently used to notify documents to be approved by the various parties involved. Given the overall size of the project and the operational needs of the sites, documents approval was carried out by subdividing the detailed design documents into lots, and this has resulted in the need for certain traceability of the documents submitted for approval in each lot; this problem has been solved by resorting to flat sets. Flat sets are a sort of virtual folders containing dynamic links to individual documents, regardless of their position in the archive. The documents are directly accessible from the set. The dynamic links allow the user to display the documents of the sets and the related attributes, with the certainty that the user is accessing the current versions of documents and attributes.

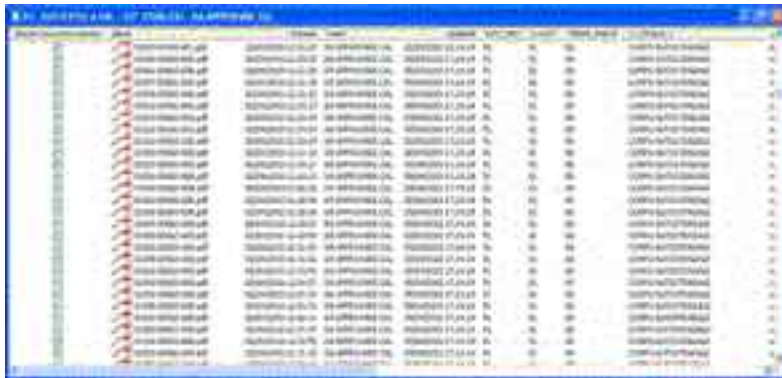

Figure 8 Example of FLAT SET

Flat sets are populated by 'drag and drop' functions and are stored in ProjectWise in a specific area reserved to notifications. Any individual approver can directly access documents in the sets, display their contents, change status, view and modify attributes, add comments, etc., during the approval phases.

## 7 Document management in the Construction Environment

Documents generated during the entire construction process are managed in ProjectWise. The site works documentation is uploaded into the ProjectWise Integration Server from the client workstations located in Brescia. The structure of the archive storing construction documents is organized by document type rather than by work; this is so because in the construction phase, control and approval workflows are divided into operational phases (e.g. quality documents, accounting documents, control and management documents, etc.).



Figure 9 Construction Environmental Folders Structure

### 7.1 Coding Scheme for the Construction Environment

Documents encoding follow the same structure applied to the final design, breakdown of work. In this way it is possible to search construction documents by document type, by WBS, or by a combination of both. In this case, the structure of the 32-digit code follows the creation of logic shown hereunder.



Figure 10 Documents coding scheme in the Construction Environment

## 7.2 Construction Environment Workflow

Documents approval workflow in the construction phase consists of three steps. When a document is uploaded into ProjectWise from site personnel, the status takes on the 'CARICATO – FILED' status. The Site Operations Manager, after checking it, can assign the 'DA APPROVARE AS - TO BE APPROVE BY AS' status. At this point the document is accessible by the Surveillance Authority who conducts due audits, approves the document and takes it to the 'APPROVATO AS – APPROVED AS' status. Finally, the Concessionaire orders the posting of the document by passing it to the 'FINAL' status and by making it visible to the concerned parties.

## 8 Benefits resulting from the adoption of ProjectWise

The decision to use a document management system is proving to be of utmost importance in a geographically dispersed and complex setting such as the one of the Brebemi project. These are some of main benefits which can be gained: time savings in communications among the various participants to the project; project and procedure document sharing and control; better “engineering” of the project itself in terms of graphic and text standardization; definition, implementation and generalized use of linear and shared workflows and testing procedures. Other benefits can be found in the openness of the system, which allows the data to be acquired from different environment; its configuration flexibility allows it to adapt to various data clusters and posting arising in the development of a complex project such as Brebemi. In summary, the use of ProjectWise has allowed to obtain a series of benefits, including:

- Centralize information to allow easy access by authorized users with appropriate security mechanisms;
- Structured and standardized information to simplify the performing of search, access, enquiry and rendition operations;
- Allow access from a single environment to all information in the company through an expandable modular technology;
- Provide the system administrator with flexible, customizable, adaptable tools to manage the specific information of a large and complex project;
- Provide users with a simple interface that allows to perform operations such as uploading, retrieval, consultation, modification, description and reporting of information in a familiar environment similar to Windows;
- Exploit full integration with Adobe PDF and CAD documents;
- Streamline the workflow during the entire project life cycle;
- Improve quality and efficiency in the management of static and dynamic project information;
- Increase data and company value, by implementing the chosen quality procedures;
- Trust the reliability and uniqueness of documents when converted from paper to electronic formats.



## APPLICATION OF MULTICRITERIA ANALYSIS FOR SELECTION OF ALTERNATIVE IN THE ROAD PROJECTS

Aleksandar Glavinov<sup>1</sup>, Zoran Krakutovski<sup>2</sup>,  
Slobodan Ognjenovic<sup>2</sup>, Katerina Mitkovska–Trendova<sup>1</sup>

*1 University Goce Delcev, Military Academy General Mihailo Apostolski,  
Republic of Macedonia*

*2 University Sts. Cyril and Methodius, Faculty of Civil Engineering Skopje,  
Republic of Macedonia*

### Abstract

The importance and public nature of road infrastructure requires involvement of many stakeholders in the process of decision making in the democratic societies. The usage of Multi-Criteria Analysis (MCA) is a pertinent tool in decision making when some of specific objectives are imperative to achieve. Besides, the road infrastructure is very important for the system of civil protection and defence for all countries. This work shows the methodology for definition of criteria and determination of weight for each criterion. The following six main criteria are assessed: traffic flow, impact of spatial plan, civil engineering criteria, economical and financial criteria, environmental criteria, criteria for defence and system of civil protection. More specific sub-criteria are defined in each group of main criteria. The questionnaire with a list of main and specific criteria is sent to several institutions and experts in the country to give their opinion thereon, or to estimate each main criterion (first step of weighting) as well as to assess each sub-criterion (second step of weighting). The results of the survey concerning measurement of the importance of each criterion are used to develop Multi-Criteria Analysis. The assessment of three variants of road infrastructure is calculated through three methods of MCA: Sum Weight Method (SWM), Analytic Hierarchy Process (AHP) and ELECTRE. The comparison and recommendation for usage of MCA and choice of the calculation method is also provided in this work.

*Keywords: multi-criteria analysis, road infrastructure, criterion, weighting.*

### 1 Introduction

The planning and the execution of the road infrastructure are complex projects which are of interest to many subjects. Specially interesting is the theoretical investigation of decision making in road projects, arrangements of the space for the defense needs and the application of multicriteria analyses in the process of decision making for the road infrastructure projects. This paper deals with the methods of multicriteria decision making as assistance to the 'decision maker' to identify the best agreed solution. In addition the improved techniques to typify the priorities and incorporate them in the decision making analysis has been displayed. Analysis of the road infrastructure has been made and a methodology for multicriteria analysis application in decision making process related to the roads has been suggested.

## 2 Criteria for assessing the conditions of the state road network including the defence needs and the civil protection system

Application of multicriteria analysis as a support in decision making when selecting projects related to the road infrastructure requires identification and consideration of the preferences of the concerned subjects in the decision making process. An assessment of the importance of the criteria in the decision making process for the road net related projects and by considering the defence needs has been made by the use of a questionnaire.

A sample involved in the questionnaire has been taken by the ministries and the independent authorities of the government the highest level being the head of a sector, the higher education institutions, professors, distinguished experts and heads of advisory teams and logistics experts.

The questionnaire has been structured in two parts. The first part represents six basic criteria displayed in table 1.

**Table 1** Basic criteria

Number	BASIC CRITERIA	Mark
1.	Traffic criteria	TC
2.	Spatial criteria	SC
3.	Design – building criteria	DBC
4.	Economic and financing criteria	EFC
5.	Environment related criteria	ERC
6.	Defence related criteria	DRC

The second part defines the subcriteria for each of the abovementioned basic criteria in the questions and the possible measures for them. Four subcriteria have been proposed for the traffic, three for the spatial ones, eight for the economic, four for the building one, six for the environment protection and six defence subcriteria.

Such prepared questions were distributed to the relevant subjects to give weighting coefficient to each criterion and subcriterion. Out of the 50 questionnaires sent, 40 respondents were received (80% respondents).

From the obtained responses and the allocated weighting it could be noticed that they are in accordance with the scope of interest and the subjects' competencies that mark the given criteria in the questionnaire. In order to avoid allocation of 100% coefficient for a single criterion, the methodology for questionnaire filling contains a condition that the maximum allocation for a certain criterion shouldn't surpass 60%. With this limitation each interviewed subject (expert of certain area) besides the mark for the criteria should determine and give a preference for the other criteria from the list.

From the received results, it could be concluded that the highest mark i.e. weighting coefficient, the 40 respondents gave to the fourth criteria i.e. 'the economic and financing criteria' and it is 26.10%, while the lowest weighting coefficient is 'building criteria' and it is 6.20%. These results have been applied into the next applicative example which illustrates the use of obtained data.

### 3 Applicative example

The considered example refers to three variants from a road project and it is necessary to determine the most desired variant solution. Needed data (weighting coefficient) of the criteria and the subcriteria will be taken from the marks given in the conducted questionnaire. For analysis the following methods will be used: Method for full aggregation of the final result which is the

- Weight Sum Method (WSM – Weight Sum Methode);
- Method of analytic hierarchy process (AHP – Analytic Hierarchy Process) and
- Method of partial aggregation or method ELECTRE 1.

**Table 2** Multicriteria matrix

VARIANTS	Criteria						
	TC	SC	DBC		EFC	ERC	DRC
	Traffic intensity	Maximum skew/slope of grade level	Investment expenses	Exploitation expenses	Contamination of the atmosphere	Linking the populated places	Linking the defence directions
	T1 (AADT)	S1 (%)	DB1 (103 €)	DB2 (103 €)	EF1 (descriptive)	ER1 (descriptive)	D1 (descriptive)
Variant road 1	6210	3,010%	67,2	601,2	90%	80%	100%
Variant road 2	6910	3,200%	70,3	572,3	80%	100%	90%
Variant road 3	7020	3,400%	68,1	594,7	100%	90%	80%
Weighting coefficient	0,21	0,06	DB1 = 0,17 0,09	DB2 = 0,26	0,13	0,12	0,22

Characteristics of the three variants for which a comparison of seven criteria should be conducted and a mark should be allocated for selection of an investment project are displayed in the table 2.

Total expenses in the exploitation are a sum of exploitation expenses of the vehicles, maintenance expenses, traffic accidents expenses and expenses from the time of traveling, discounted to the first year of exploitation. Weighting coefficients are obtained from the questionnaire conducted as part of this work.

#### 3.1 Weight Sum Method (WSM)

Applied method for comparing the variants is with a sum of weighting values of the separate criteria, i.e. by the method of a global sum. Since the values of each criteria are expressed in the natural measuring units or descriptively and differ regarding the criteria and in order to make the comparisons, the values of each criterion should be brought to a non dimensional size and to establish a non dimensional matrix, i.e. to start the procedures known as normalization of the measures of the criteria. This normalization is carried out with different attributes assigned for each criteria and each variant in a comparable size and at the same time the preference for each criteria is determined as to whether the most desired solution is the highest or lowest measuring value (Table 3).



**Table 3** Non dimensional matrix according to WSM

Variant	Criteria						
	T1 (+)	S1 (-)	DB1 (-)	DB2 (-)	EF1 (+)	ER1 (+)	D1 (+)
1	0.8846	1	1	0.9519	0.900	0.800	1
2	0.9843	0.9406	0.9559	1	0.800	1	0.900
3	1	0.8853	0.9868	0.9623	1	0.900	0.800
Weight	0.21	0.06	0.17	0.09	0.13	0.12	0.22

Determination of the global result for each of the three variants is as follows:

- Variant one:  $\Sigma W = 0.8846 \times 0.21 + 1.00 \times 0.06 + 1.00 \times 0.17 + 0.9519 \times 0.09 + 0.9000 \times 0.13 + 0.8000 \times 0.12 + 1.00 \times 0.22 = 0.937$
- Variant two:  $\Sigma W = 0.9843 \times 0.21 + 0.9406 \times 0.06 + 0.9559 \times 0.17 + 1.00 \times 0.09 + 0.800 \times 0.13 + 1 \times 0.12 + 0.900 \times 0.22 = 0.934$
- Variant three:  $\Sigma W = 1.00 \times 0.21 + 0.8853 \times 0.06 + 0.9868 \times 0.17 + 0.9623 \times 0.09 + 1.00 \times 0.13 + 0.90 \times 0.12 + 0.800 \times 0.22 = 0.931$

According to this calculation, the best valued variant is the variant B1, although the results from the calculations show a small difference in the summed result.

### 3.2 Analytic Hierarchy Process (AHP)

Analytic Hierarchy Process (AHP) is a method of multicriteria analysis which enables modelling of complex problems in the hierarchical structure which represents the relations among the criteria, subcriteria and possible variants.

With this method, the weighting coefficients are measured and allocated as ratio among the criteria and not like assigned ones, i.e. assessed weighting coefficient for each criteria. AHP is based on three basic principles: decomposition, comparative assessment or synthesis of priorities. Decomposition refers to establishing hierarchical branching. The principle of comparative assessment refers to the comparison of pairs of all possible combinations. Principle of synthesis comprises of multiplication of local priorities in a group with global priority.

The application of the AHP method over an example will be represented for selection of one of the three variants of road with criteria out of which the economic criteria have been divided in two subcriteria or there are totally seven criteria according to which the variants are valued. The best valued variant according to the AHP method has been shown in the table 8.

According to this calculation, the best valued variant is also variant B1. Only the difference in the obtained results is more evident than in the previous method SWM.

**Table 4** Grades used in mutual comparison in AHP method

Intensity (significance)	Definition	Explanation
1	Identical significance	Two variants are equally significant in relation to the goal
3	Medium significance	More desired variant
5	Important significance	Strongly desired variant
7	Very important significance	Absolutely confirmed more desired variant
9	Extreme significance	Extreme more desired variant with highest confirmation

Intensity of 2,4,6 and 8 can also be mentioned (Source: T.L. Saaty, The Analytic Hierarchy Process, McGraw-Hill, (1980))

**Table 5** Weighting coefficient at a criteria level according to the AHP method

Criteria comparison	(TC)	(SC)	(DBC)	(EFC)	(ERC)	(DRC)	Suma	medium value
TC	1.00	6.00	0.50	4.00	3.00	2.00	16.50	0.251
SC	0.17	1.00	0.14	0.33	0.50	0.20	2.34	0.036
DBC	2.00	7.00	1.00	5.00	4.00	3.00	22.00	0.334
EFC	0.25	3.00	0.20	1.00	2.00	0.25	6.70	0.102
ERC	0.33	2.00	0.25	0.50	1.00	0.33	4.42	0.067
DRC	0.50	5.00	0.33	4.00	3.00	1.00	13.83	0.210
	4.25	24.00	2.43	14.83	13.50	6.78	65.79	1.00

**Table 6** Normalization of weight coefficient at a criterial level accroding to the AHP method

Criteria comparison	(TC)	(SC)	(DBC)	(EFC)	(ERC)	(DRC)	Suma	Weight coefficient
TC	0.24	0.25	0.21	0.27	0.22	0.29	1.48	0.246
SC	0.04	0.04	0.06	0.02	0.04	0.03	0.23	0.038
DBC	0.47	0.29	0.41	0.34	0.30	0.44	2.25	0.375
EFC	0.06	0.13	0.08	0.07	0.15	0.04	0.52	0.086
ERC	0.08	0.08	0.10	0.03	0.07	0.05	0.42	0.070
DRC	0.12	0.21	0.14	0.27	0.22	0.15	1.10	0.184
	1.00	1.00	1.00	1.00	1.00	1.00	6.00	1.000

**Table 7** Calculation with combined pondering with weight coefficient according to the AHP method

Weight 1	0.246	0.038	0.375	0.375	0.086	0.070	0.184
	(TC)	(SC)	(DBC)		(EFC)	(ERC)	(DRC)
Weight 2	-	-	0.67	0.33	-	-	-
	AADT	Skew/slope grade level	Investment expenses	Exploitation expenses	Atmosphere contamination	Linking populated places	Linking defence directions
B1	0.11	0.54	0.72	0.11	0.30	0.14	0.54
B2	0.26	0.30	0.08	0.63	0.16	0.62	0.30
B3	0.63	0.16	0.19	0.26	0.54	0.24	0.16

Weight 1	0.246	0.038	0.375	0.375	0.086	0.070	0.184
	(TC)	(SC)	(DBC)		(EFC)	(ERC)	(DRC)
Weight 2	-	-	0.67	0.33	-	-	-
	ПДЦ	Skew/slope grade level	Investment expenses	Exploitation expenses	Atmosphere contamination	Linking populated places	Linking defence directions
B1	0.03	0.02	0.18	0.01	0.03	0.01	0.10
B2	0.06	0.01	0.02	0.08	0.01	0.04	0.05
B3	0.16	0.01	0.05	0.03	0.05	0.02	0.03

**Table 8** The best valued variant according to the AHP method

FINAL RESULT	RANKING	
B1	0.38	1
B2	0.29	3
B3	0.34	2
	1.00	

### 3.3 ELECTRE 1 – model for decision making with sequential classification

ELECTRE 1 (Elimination Et Choix Traduisant la Réalité) is a method which enables to lead to subject which makes a decision in its choice of one possible activity (a) in the set A of activities knowing that many criteria of preferences should be considered from non aggregated characteristics of the possible activities. ELECTRE 1 is a method of divide in the presence of many criteria. More precisely, it is a method which enables bipartition in A, between the selected activity (i) and the other activities A-1 which are eliminated. So, this method uses the technique of comparison of each variant. By applying this variant the results is that the variant B1 dominates the other two variants and is the best valued variant.

## 4 Conclusion

Previously pointed methods for road infrastructure projects' assessment are applicable and should be part of a process for variants assesment. It is important to include all the interested subjects from the project in the project monitoring body which by its participation will contribute to the assesment of the most desired project. This research has considered a criterion which assesses the variances from the aspect of the defence needs.

The results show that the obtained global results from the evaluation of the three variances are very close. Therefore, analysis of the results' sensitivity when the input parameter for the variant attributes change should be made. One probability approach to determine the input parameters would be more objectively acceptable concept for multicriteria analysis application.

## References

- [1] Koski, J (1985), 'Defectiveness of weighting method in multicriterion optimization of structures', *Communication in Applied Numerical Methods*, Vol. 1, Issue 6, pp. 333-337
- [2] Saaty, T. L. (2006): 'Fundamentals of Decision Making and Priority Theory with he Analytic Hierarchy Process', Vol VI of the AHP Series, RWS Publications, 2006.
- [3] Roy, B. and Figueira J., (1998): 'Détermination des poids des critères dans les methods de type ELECTRE avec la technique de Simos revise', Université de Paris-Dauphine, Doc. du LAMSADE n°109.
- [4] Kim IY, de Weck OL (2005), Adaptive weighted sum method for bi-objective optimization: Pareto front generation, *Struct MULTidiscipl Optim* 29: 149-158
- [5] Saaty, T. L., (2001): 'Decision Making For Leaders: The Analythic Hierarchy Process for Decisions in a Complex World'. RWS publications, Pittsburgh. 1990, new-edition.
- [6] Roy, B. (1996): 'Les logiques compensatoires et les autres', in: *Proceedings des 44èmes Journées du Groupe de Travail Européen Aide Multicritère à la Décision*, Bruxelles, Belgique.
- [7] Roy, B., (1990): 'The out ranking approach and the found ations of ELECTRE methods'. In C.A. Banae Costa, editor, *Readings in Multiple Criteria Decision Aid*, pages 155-183. Springer-Verlag, Berlin.



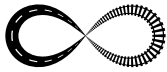

## STRATEGIC TRANSPORT INFRASTRUCTURE IN SOUTH EAST EUROPE: PLANNING EXPERIENCE AND PERSPECTIVES IN THE CONTEXT OF THE EUROPEAN TRANSPORT POLICY

**Marios Miltiadou, Socrates Basbas, George Mintsis, Christos Taxiltaris, Anthi Tsakiropoulou**  
*Aristotle University of Thessaloniki, Faculty of Rural and Surveying Engineering, Dept. of Transportation and Hydraulic Engineering, Greece*

### Abstract

South East Europe (SEE) is a region of high importance for the European Union (EU). Especially concerning Transport, this importance accrues from the fact that this region is a part of the European continent, but at the same time it is a discontinuity zone of the Trans-European Transport Networks (TEN-T).

The European Transport Strategy for the non-EU regions has been expressed in the '90s through the Pan-European Corridors (PECs) and Areas (PETRAs) concept, but moreover, in this particular region it was more intensively expressed after 2001, with the definition of the SEE Strategic Network and of the SEE Core Transport Network, in view of the EU enlargements, which would cause the incorporation of entire PECs or parts of them into the TEN-T. Then, the European Commission (EC) initiated the revision of the PECs' concept, proposing five Priority Axes, and among them the South Eastern Axis that covers the SEE region, the Caucasus, Turkey, Middle East and Egypt.

In this aspect, taking into consideration the development already made on the networks of the acceding countries, a new orientation for extension of the transport networks for a wider Europe has been initiated. Especially for the development of the South Eastern Axis, with the aim to boost the development of transport infrastructures in the SEE region, the PECs' structures, Transport Ministries and the SEE Transport Observatory (SEETO) are engaged in the SEE Transport Axis Cooperation (SEETAC), a project funded by the SEE Trans-National Programme. In this paper, an overview of the general framework and the followed methodologies for priority project definition and promotion is presented, together with intermediate results of the analysis of the existing situation carried out within the SEETAC project. Perspectives for development and priority projects are presented based on these results, other studies and the TEN-T framework, which is currently under revision.

*Keywords: Infrastructure Projects, European Transport Strategy*

### 1 Introduction

This paper presents the implementation of the European Transport Strategy in the SEE and especially in the so called 'Western Balkans'. The Western Balkans (WB), regardless of the different stage of integration of the various countries, is considered as a region of special and high importance for the EU, being a part of the European continent with clear EU orientation. Therefore, the extension of the major trans-European axes to these neighbouring countries is essential.

The first aim of the paper is to present the general transport strategy for infrastructure development for the non-EU regions, with special emphasis on the strategic networks in SEE. More-

over, this paper focuses on the perspectives in the context of the current European Transport Policy, the revised framework for transport infrastructure planning after the EU enlargements of 2004 and 2007 and the most recent proposal for the revision of the TEN-T Guidelines in 2011.

Furthermore, this paper aims to present the followed methodologies for priority project definition and promotion after more than ten years of planning experience in the framework of the European Transport Strategy, together with the results of the analysis of the existing and future situation in the SEE region carried out within the SEETAC project and other relevant studies. The methodology to approach the aim of the paper consists of: a) the presentation of the PECs in the region and the SEE Strategic and Core Networks; b) the presentation of the revised framework for transport infrastructure planning in neighbouring countries/regions after the EU enlargement; c) the presentation of results of the analysis of the existing situation concerning the supply and the demand in the SEE region (carried out within the SEETAC project); and d) the formulation of comments and conclusions, for the strategic transport infrastructure planning and the project priorities definition in the SEE region.

## 2 Corridors in the region – SEE Strategic and Core Networks

In the '90s, especially after the Maastricht Treaty, the EC carried out extensive planning exercises to define and promote the TEN-T for the Member States and the neighbouring countries. Even before the TEN-T guidelines definition in 1996, it was recognized that there is a need for further planning in SEE, in order to involve the non-EU regions. In this aspect, at the Pan-European Transport Conferences of Crete (1994) and Helsinki (1997), the Pan-European Corridors (PECs) and Areas (PETRAS) for the non-EU European territories were defined.

The “grid” of PECs in the SEE region consists of PECs IV (North-Southeast), V (West-East), VII (the Danube Inland Waterway), VIII (West-East), IX (North-East) and X (Northwest-Southeast). Additionally, three out of the four PETRAS are sited in SEE: the Adriatic – Ionian Seas, the Mediterranean Basin and the Black Sea Basin. For the documentation and prioritisation of projects, as well as for the examination of the development potential of the transport sector in general and especially PECs’ infrastructure, various regional planning exercises, strategic studies and inventories were elaborated.

More specifically, one of the extensive planning exercises, in order to define the TEN-T for the Member States and the accession countries, was the Transport Infrastructure Needs Assessment (TINA). Based on the PECs, TINA contributed to the coordination of the infrastructure investment plans of the eleven (then) acceding countries with those of the EU member states, in view of the extension of the TEN-T to the enlarged EU. There was obviously a gap on the European map and rationally it was then recognized, that there was also need for further planning to involve the five (then) countries of the WB participating in the Stabilisation and Association Process.

In these terms, the European Transport Policy was further enhanced, on the basis of the already established PECs, with the SEE Strategic Network definition in 2001 [1]. Two strategic studies, similar to TINA, were elaborated immediately after: the Transport Infrastructure Regional Study (TIRS) [2] and the Regional Balkans Infrastructure Study (REBIS) [3], and the SEE Core Transport Network was defined (nowadays called 'SEE Comprehensive Network', in order to avoid misunderstanding with the term 'Core' used in the current TEN-T revision process), as well as lists of priority projects.

### 3 Enlargement and revised framework for transport infrastructure planning in EU neighbouring countries and regions

In view of the EU enlargements, which would lead to the incorporation of entire PECs or parts of them into the TEN-T, the EC initiated the revision of the PECs' concept. The 14 Priority Projects (PP) defined in 1996 became 30 in 2004, for the enlarged EU. Sections of the PP 6 (Railway axis Lyon - Trieste - Divača/ Koper - Divača - Ljubljana - Budapest - Ukrainian border), PP 7 (Motorway axis Igoumenitsa/ Patras - Athens - Sofia - Budapest), PP 18 (Waterway axis Rhine/ Meuse - Main - Danube) and PP 22 (Railway axis Athens - Sofia - Budapest - Wien - Praha - Nürnberg/ Dresden) coincide with the Railway PEC V, Road PEC IV, Inland Waterway PEC VII and Railway PEC IV respectively.

At Pan-European level, the EC [4] proposed five 'Priority Axes' (Sea Motorways, Northern Axis, Central Axis, South Eastern Axis and South Western Axis), which would contribute to the promotion of international exchanges, trade and traffic between the EU and its neighbours, with additional branches (with lower traffic volumes) for regional cooperation enhancement and integration in the long term. The 'South-Eastern Axis' in the SEE region is actually the network of the existing PECs; although some parts of them are excluded (Branches B of PEC V and D of PEC X, plus PECs IV and IX, which are now parts of the TEN-T). This Axis was actually the inspiration of the SEETAC establishment.

Cooperation in the transport field and the extension of the *Acquis Communautaire* to the new EU member states, the candidate and the potential candidate countries of the SEE region is more advanced than for the other partner countries of the EU that are included in the European Neighbourhood Policy. Therefore, the EC suggests that cooperation in the WB should focus on the SEE Core Network development and encourages the countries to speed up alignment of their national legislation with the *Acquis Communautaire* on transport and relevant thematic areas, in order to fully benefit from the accession framework. The EC and the countries of the region are for years now negotiating a Treaty for the establishment of a Transport Community in SEE, targeting at the establishment of an integrated market for infrastructure and land, inland waterways and maritime transport and of course the adjustment of the relevant legislation in this region. However, due to political reasons the Treaty has not yet been signed.

In the Member States the TEN-T Programme consists of projects (defined as studies or works), whose ultimate purpose is to ensure the cohesion, interconnection and interoperability of the TEN-T as well as the access to it. The Priority Projects and other horizontal priorities, as a whole, are established to concentrate on Pan-European integration and development and aim to establish and develop the key links and interconnections needed to eliminate existing bottlenecks to mobility, fill in missing sections and complete the main routes, especially their cross-border sections, overcome natural barriers and improve interoperability on major routes.

In late 2011, the EC adopted a proposal to transform the existing patchwork of European roads, railways, airports and canals into a unified TEN-T and, among others, to promote projects of mutual interest, including extensions to the neighbouring countries and regions [5]. A dual layer TEN-T is proposed: the 'Comprehensive' and the 'Core'. Especially the second is envisaged to improve connections between different modes of transport and provide adequate connections to neighbouring countries, ensuring geographical coverage.

More specifically, the projects of mutual interest aim to connect the TEN-T with the networks of third countries (covered by the Enlargement Policy, the European Neighbourhood Policy, the European Economic Area and the European Free Trade Association) and seek to connect the Core TEN-T at border crossing points, ensure the connection between the Core TEN-T and the networks of the third countries (like the SEE Core Network), complete the transport infrastructure in third countries which serve as links between parts of the Core TEN-T and implement traffic management systems in those countries. Such projects shall enhance the capacity and utility of networks located in the SEE countries.



## 4 SEETAC interim results for the existing situation

### 4.1 SEETAC content

The SEETAC project main technical activities concern: a) the establishment of a detailed and harmonised database for the existing and future situation of the SEE transport infrastructure and b) the development of a transport model for the simulation and assessment of the existing situation and the examination of development scenarios (demography, economy, trade, new projects implementation) for the future (target year 2030) and their impact on transport operations and the environment.

The reference network (Figure 1) consists of the strategic infrastructure (TEN-T, PECs and SEE Core Network – consisted of PECs and important routes in the WB), as well as some other sections useful for modelling purposes, and concerns roads, railway lines, inland waterways and their interconnection points with the ports and airports in the region.



**Figure 1** SEETAC study Road (left) and Railway (right) Networks [6]

The simulated road network consists of 373 links with total length of 23.920km and the railway network of 301 links with length of 19.085km in total.

For these networks a very detailed survey was performed in order to collect data for the physical (geometrical) and operational characteristics of each one of the networks' links and nodes. This survey allowed the establishment of the SEETAC study network database and the construction of the SEETAC transport model with appropriate geo-reference and assignment of the appropriate attributes to its components.

Through the transport model it is possible to have various functions for the assessment of the network, e.g. the identification of main trips generators and attractors, saturated links and nodes, corridors and nodes of national (but mostly regional/international) importance. Furthermore, the model shall test the impact of the priority projects implementation on the traffic assignment on the network under study, for the target year of the traffic forecast, year 2030.

For the examination of the future situation of the infrastructure (supply), a data collection is under elaboration concerning projects under implementation or underway for implementation (secured financing), as well as on projects included in the national transport plans and which are also part of the TEN-T and SEETO planning.

## 4.2 Results of the inventory on existing situation of Roads and Railways

A very detailed database has been established up today [6], which refers to the existing situation of the transport network (geometrical/ physical and operational characteristics) of the various transport modes, based on the information provided to the EC (DG Mobility and Transport) by the EU Member States and to the SEETO by the WB countries, for TENtec and SEETIS systems, respectively.

The total length of PECs in the region under study is 9.594km of roads and 10.530km of railway lines. From the initial processing of this database and per PEC, it emerges that the infrastructures on the main PECs running through the region are more or less developed: 53,1% of the roads are with 2 or more lanes per direction, 51,4% of the PECs (existing) railway lines are with double tracks and 83,7% of the PECs railway lines are electrified.

Regarding the road network, the length of motorways and expressways (2 or more lanes per direction) on PEC X represents 72,3% of its total length and on PEC V represent 60,8% of its total length (Figure 2).

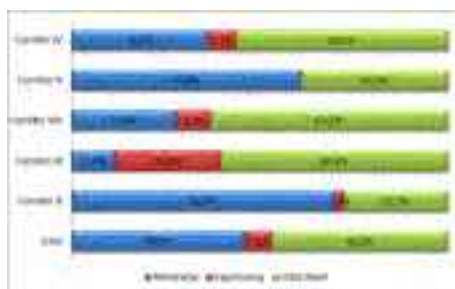

Figure 2 Typology of PECs Roads in SEE (% of the total length).

Regarding the railway network (Figure 3), the length of double tracks on PEC IV represent 64,7% of its total length, on PEC V represent 52,6% of its total length and on PEC VIII 50,7% of its total (constructed) length.

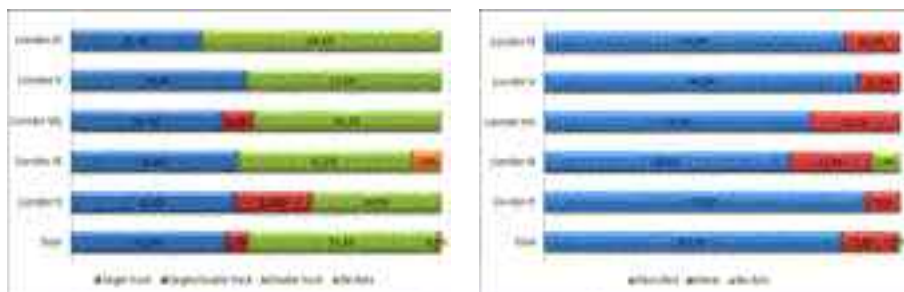

Figure 3 Typology of PECs Railway Lines in SEE (% of the total length)

Furthermore, through the transport model (after trips assignment on the network and the calibration to the observed traffic), traffic and capacity analyses have been performed, through the assessment of the flows over capacity ratios for each road and railway links of the network. The results of these analyses are depicted in Figures 4 and 5, respectively for the road and the railway links.

It can be observed that the biggest share of transport flows is concentrated on the PECs running through the region: On the road network on PECs IV, v and x (and less on PECs VIII and IX), and on the railway network on PECs IV, v and x. Saturation problems appear only at road

sections around important cities of the region (Salzburg – Innsbruck, Milan, Bucharest and Sofia) and on railway lines on the Austrian network, in Slovakia (Bratislava – Gyor), southwest of Ljubljana on PEC V, and on PEC IV, mainly between Plovdiv and Haskovo in Bulgaria.



Figure 4 Volume over Capacity ratio on SEETAC study Road Network [7]



Figure 5 Volume over Capacity ratio on SEETAC study Railway network [7]

### 4.3 Future transport demand in SEE

Concerning the future demand, the scenarios development within SEETAC are under formulation, so there aren't any results for the time being. However, there are other studies with reference to this region, the EUN STAT [8] and the TEN-CONNECT [9].

The first one concerned the freight traffic flows forecast between the EU and the neighbouring countries and regarding the SEE region it concluded that in the future (target year of the forecast 2020) the freight traffic flows will be concentrated on the road corridors between Turkey – Bulgaria – Western Balkans – Germany/ Northern Italy and Bulgaria – Romania – Russia and on the railway corridor between Bulgaria – Romania – Ukraine and Russia.

The second forecast, not only dedicated to freight, concluded that on the SEE road network the PECs with the biggest flows are PEC x (Main Axis from Austria to Belgrade and Nis and Branch c to Sofia) and PEC IV from Sofia to Istanbul. The same applies for rail passenger traffic and to some extent for rail freight traffic, where PEC IV is more loaded on its parts in Romania and its eastern part in Bulgaria near the border with Turkey, and also on PEC IX south of Bucharest.

## 5 Transport project prioritisation in SEE

### 5.1 Prioritisation in previous strategic exercises

Projects are placed among national, regional and international (Pan-European) policies, and therefore in a 'pool' of projects, out of which, usually through Multi-Criteria Analyses (MCA), it results the prioritization of implementation of the most urgent projects.

Therefore, the strategic planning at Pan-European level, dealt with the definition of the most urgent and with international impact projects. According to the TEN-T first guidelines (1996), the processing for the formulation of project proposals for financing focused in three terms: 'projects of common interest', 'bottlenecks' and 'missing links'.

Earlier (1993-1994), for the wider European Network, the Economic Commission for Europe of the United Nations (UNECE) and the European Council of Ministers for Transport (ECMT) worked on the methodology for defining common criteria for the identifying bottlenecks and missing links. On the definition of the term 'bottleneck' worked later the studies TEN-NAxis [10] and TEN-CONNECT assigned by the EC, whilst in the mean time the HCM and the UIC guidelines were respectively the basic tools for road and railway infrastructure capacity assessment.

In the very beginning the priorities had been set for some of the PECs by their structures and for the TEN-T through their initial definition (14 priority projects), and later on for the SEE by the general guidelines of the EC strategic guidelines of 2001.

On the basis of these EC guidelines, each of the strategic exercises elaborated for the transport infrastructure development in SEE included methodologies for prioritising the projects with major importance for the region.

Especially for the wider SEE region (WB, Romania and Bulgaria), the TIRS was based on the ECMT methodology and developed a weighted MCA to assess the potential projects, according to two main groups of criteria, i.e. the socioeconomic return on investment and the functionality and coherency of the network.

On the same direction, the REBIS developed a weighted MCA with six major criteria categories, but for a more limited network (SEE Core Network): economic appraisal, financial viability environmental effects, functionality and coherency of the network, readiness of the authority to implement a project and speed of implementation.

For the same network, SEETO consultants [11] in 2006 defined the criteria for prioritising projects when preparing the Multi-Annual Plans for the realisation of the SEE Core Network (defined through the REBIS). It categorised the criteria to five groups concerning regional interest, economic and development impact, financial sustainability, environmental and social impact and technical standards.

These MCA methodologies are apparently valuable in the process of the SEE transport network development. However, there are criteria which are more or less linked to the political component of a project, i.e. the national priorities but also the overall EU transport strategy (PECs). In other words, between the projects of the TIRS network, it was obvious that the projects on the PECs in the region would be prioritised. Firstly because they belong to PECs, secondly because they are already prioritised by the national governments (as parts of the PECs and thus as easier to secure funds) and finally because the demand in the region is concentrated on these PECs. So it was obvious that they meet the criteria of functionality and coherence of the network, the regional importance and the importance for international transport.

## 5.2 Project prioritisation in SEETAC

During the elaboration of the SEETAC, it was initially planned to prioritise projects following a detailed MCA, similar to those applied in the aforementioned exercises. A detailed methodology was presented to the project partnership and the EC, but it was decided that no other priorities than those already defined by the SEETO and the EC should be defined.

Therefore, the prioritisation that would emerge from this project should be to define priorities between priorities, i.e. to define the most urgent and mature projects for realisation, which should meet the several criteria (planning, financial and technical) adjusted to the recommendations of EC proposal for the new TEN-T Guidelines: a) belong to the EU proposed Core or Comprehensive TEN-T or the SEE Comprehensive Network, b) provide link between these networks, mainly at border crossing points, c) ensure connection between the Core TEN-T and the transport networks of third countries, d) facilitate maritime transport by providing links to main ports, e) serve the majority of international transport flows, f) ensure and promote interoperability and multimodality, g) ensure financial and economic sustainability, h) minimise investment, maintenance and operational costs and environmental impact.

The TEN-T Regulation is under adoption (co-decision procedure), and the countries of the SEETAC partnership should, through their unified exercise, contribute to the finalisation of the new TEN-T Guidelines. The assessment of the network in the present and future situation contributes to the redefinition of the critical routes on the SEE transport network and the investment needs for development. The results of this assessment will be presented in a dedicated Ministerial Meeting of the SEETAC partnership and an Infrastructure Forum in May 2012 in Athens, with the presence of the EU instruments, the International Financial Institutions and various relevant stakeholders from the Europe and the SEE region.

## 6 Conclusions and perspectives for the SEE Transport Network

From the topological consideration of the Pan-European Networks according to Bunge (1962) and according to the networks attributes that Dupuy (1985) and Chesnais (1982) later defined, it emerges that it is a network characterised by anisotropy, but has high density (networks length per surface unit that they serve), multiplicity and high connectivity capacity of nodes in Western Europe, in contrast to their regional development in SEE. Additionally in the Western Europe we can observe homogeneous and exclusive sub-systems (high speed railway networks TGV/LGV, aviation networks, conventional railway networks and closed motorways' networks), which are adequately interconnected, with elements of interoperability and intermodality [12].

On the contrary, on the SEE network, there is high heterogeneity, which, combined with the physical barriers, the political instability and the various institutional or technical barriers at borders, creates a complex area for transport. In this area there should be developed multi-modal and efficient transport systems.

Obviously, the SEE transport infrastructure needs further development for the connectivity and accessibility of the countries in the region, apart from the general aim to serve the needs for economic, social and territorial cohesion.

The transport networks in SEE, defined through the various planning exercises briefly described in this paper, are not arbitrary. They are pre-existing, historical networks, a priori strategic for the countries concerned, which have been adequately developed in the past, but due to economic reasons have been neglected and did not manage to follow the development achieved in the EU countries, so they lag behind the EU standards.

Therefore, despite the scarcity of funds, the development of these infrastructures is one-way road. The discussion in the process of the new TEN-T regulation definition includes firstly the inclusion of the SEE strategic network in the Comprehensive TEN-T (which in extension would mean inclusion of parts of it in the Core TEN-T upon accession of a country in the EU, i.e. Croatia in 2013) and secondly, the provision of the possibility of financing the development of this network through the new financial mechanisms (Connecting Europe Facility and IPA II) for the TEN-T implementation in the framework of EU 2020 Strategy.

Therefore, the challenge for the countries in the region and the cooperation frameworks is to align the priority projects with the projects implemented or underway in the EU neighbouring countries, in order to secure the anticipated transnational impact of the projects, the consecutiveness of the networks and therefore to maximise the added value for the EU.

## References

- [1] European Commission DG for Energy and Transport, DG for External Relations and EuropeAid Cooperation Office: Transport and Energy Infrastructure in South East Europe, 2001.
- [2] LOUIS BERGER S.A.: Transport Infrastructure Regional Study (TIRS) in the Balkans, 2002.
- [3] COWI: Regional Balkans Infrastructure Study (REBIS), 2003.
- [4] European Commission: Extension of the major Trans-European Transport axes to the neighbouring countries – Guidelines for transport in Europe and neighbouring regions, COM (2007) 32 final, 2007.
- [5] European Commission: Proposal for a Regulation of the European Parliament and of the Council on Union guidelines for the development of the trans-European transport network, COM (2011) 650/2, 2011.
- [6] Central European Initiative – Sistemi Operativi: SEETAC WP3 Interim Report, 2012.
- [7] EURAC – CSST: SEETAC Modelling Functions and Results, WP4 presentation in 8th Project Meeting, Belgrade, 2012.
- [8] NEA Transport research and training: Scenarios, traffic forecasts and analysis of traffic flows including countries neighbouring the European Union (EUN STAT), 2005.
- [9] Tetraplan A/S, Traffic flow: Scenario, Traffic Forecast and Analysis of Traffic on the TEN-T, Taking into Consideration the External Dimension of the Union (TEN-CONNECT), 2009.
- [10] WSP Finland Ltd, The Northern Transport Axis Pilot for the analytical support framework to monitor the implementation of the infrastructure and “soft” measures proposed by the High Level Group (TEN-NAxis), 2007.
- [11] GOPA – TRADEMCO: South East Europe Transport Observatory (SEETO), Technical Note 3, Multi-Annual Plan for the Development of the Core Regional Transport Network, 2006.
- [12] Miltiadou M.: Tools for the effective management and the documentation of the priorities for the development of multimodal transport infrastructures. The case of Pan-European Corridor x - PhD Thesis, 2012.



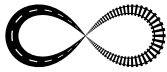

## INFRASTRUCTURAL PRIORITIES OF MODERNIZATION IN RUSSIA

**Stanislav Alexandrovich Stepanov**

*International Independent University of Environmental & Political Sciences  
(Academy IUUEPS), Russia*

### Abstract

In the conditions of globalization, its negative impacts, and also consequences of Russia's entry into the global market, there are infrastructural emergences: politics, transportation and immigration.

Transport, roads and their conditions are the most important element of the infrastructure. They affect the rate of the country's economy. Irregular development of different types of transport doesn't allow our country to use the economic benefits of the middle-country between the East and the West. It brings enormous economical losses. In recent years amount of Asian export to Europe exceeded 3 trillion dollars. In accordance with the forecast, in the next ten years only container traffic growth will be 7-10% per year. The Trans-Siberian Railway was giving income to the USSR up to 15 billion of dollars per year, which is only 1,5 billion today. There is one more road-direction of transcontinental development, that is extremely profitable but not being used by Russia yet. This is the cargo movement of goods along the Northern Sea Rout. It is almost twice shorter, than the other East-West sea routs.

In Russia the car park is growing more rapidly than in the rest of the world: 130 cars per 1 thousand people in 2000; up to 213 cars in 2008. And this is under conditions of increasing deficit of quality roads, which length should be not less than 1.5 million km. Existing length of multi-lane highways is more than 4.3 thousand km, the need for them is 8-10 thousand km. Next to the political, economic, energy and ecological dangers to the economy and citizens of our country, the immigration threat is at its peak. Therefore, modernization of the country, its regions as economical units, should be based on outstripping and complex development of infrastructure, general competitive business and economy, and decent and comfortable lives of citizens.

*Keywords: infrastructure, modernization*

### 1 Introduction

A new course of economy modernization on the way of innovative technologies, such as: nanotechnology, energy-saving technology, etc. that has been announced in Russia, doesn't take much into account the lag factor of the countries infrastructural sectors, which provide successful economic development, as well as enable favourable human habitation and development conditions. In the conditions of globalization, its negative impacts, and also consequences of Russia's entry into the world market, there are infrastructural emergences: politics, transportation and, strange to say, immigration.

Once it was said, that there are no roads in Russia, but only directions. Speaking today about the roads-directions, we must remember, that, taking into account the geographical location of Russia, they are meant to be a bridge between the East and the West. But this role can be



realized for the advantage of the Russians and their neighbours in the East and the West only when the bridge on the Russian territory becomes comfortable and good for living, works effectively and links the cultures.

## 2 Infrastructural priorities

Transport, roads and their conditions are the most important element of the infrastructure. They affect the rate of the economy of the country. Irregular development of different types of transport doesn't allow our country to use the economic benefits of the middle-country between the East and the West. It brings enormous economical losses. Thus, in recent years amount of Asian export to Europe exceeded 3 trillion dollars. In accordance with the forecast of the economists, in the next ten years only container traffic growth will be 7-10% per year. The Transsib (Trans-Siberian Railway) was giving income to the USSR up to 15 billion of dollars per year, which is only 1,5 billion today. That is only 1% of the global container shipping market, and it continues to decline. Interdepartmental red tape (railways, sea ports, long-term overload, high tariffs, and an irrational customs policy) makes Transsib uncompetitive with the maritime transport between Europe and Asia through Africa, despite multiple time shortening of transportation by the Transsib.

There is one more road-direction of transcontinental development, that is extremely profitable but not being used by Russia yet. This is the cargo movement of goods along the Northern Sea Rout (NSR). It is almost twice shorter, than the other East-West sea routes (the way from Hamburg to Yokohama via Suez Canal – 20,5 thousand km.; via NSR – 12 thousand km. of safe transportation, meaning no pirate ship seizure, plus savings of 300 tys. doll. for each vessel). Taking into account, that the Suez Canal is overloaded, and, according to IMF estimations, commodity circulation from Europe to Asia will increase in 1,5 times by 2012, plus future development of the Arctic shelf hydrocarbons and ecologically safe transportation of liquefied natural gas via NSR, the zealous economic management of this sea route can make Russia the world's transport Klondike.

Today's roads are an important component of the country security. In other words, they are the political part of the infrastructural risks. According to some analysts, the lag of Russia in the development of transport infrastructure triggers and strengthens the position of NATO and the US on encirclement, blockade and destabilization of economic and political conditions around our country. In this regard one of the European analysts anxiously stresses: "We may be cut off from Russia in civilization, geopolitical, political and energy ways. Moreover, a new wall in Europe will not take place via Berlin, but through Ukraine, dividing it into pro-Russian East and pro-American west. In accordance with the theory of separation of civilizations by S. Huntington and N. Moiseyev, this line of separation will approximately divide the continent into Catholic and Orthodox Europe correspondingly."

According to international statistics, every year 60 million new cars are being added to the number of 800 million cars in the world. In Russia, the car park is growing more rapidly (130 cars per 1 thousand people in 2000; up to 213 cars in 2008). And this is under conditions of steadily increasing deficit of quality roads, which length, as it is estimated by experts, should be, not less than 1.5 million km. With the length of the existing multi-lane highways in more than 4.3 thousand km., the need for them is 8-10 thousand km. Russia today is in the top 5 countries in the number of road accident victims. This is one of the threats to national security. Together with a lag of road infrastructure in Russia the gasification and electrification of cities and towns goes along, as well as the construction of the necessary social infrastructure – modern hospitals and schools.

Next to the political, economic, energy and ecological dangers to the economy and citizens of our country, the immigration threat is rising. Recently, Chancellor of Germany officially stated that Germany failed to adapt Muslim immigrants from Turkey. Millions of them claim to their

national and religious identity, regardless of the history, traditions and culture of the country, which sheltered them, gave them jobs, education, housing, decent social security.

As the first president of the Academy ИИУЕПС, Academician N.N. Moiseyev wrote, the present migration policy of Russia, condemns the future of Russians, living in the capital cities, and in the regions, especially near the boarders with China, Tajikistan and Kyrgyzstan, in terms of civilisation confrontation.

In this connection we believe, that modernization of Russia should go together with, so called, investment intervention in the above countries to create productions, of necessary for Russia, products and jobs, as well as the creation and reduction of unqualified immigration flow from the Asian CIS countries.

Therefore, modernization of the country, its regions as economically units, should be based on outstripping and complex development of infrastructure, a competitive business and economy, and decent and comfortable lives for citizens.

### 3 Conclusion

Since the global processes in this century will be determined by the imperatives of environmental and physical survival of the mankind, modern infrastructure will also enable Russia to overcome the state of 'catching up' development and take the way of advanced and modernized economy. Thus, the development of the economy of the country in purpose to improve the welfare of the citizens should not be at the expense of decline of living conditions of future generations of Russia (natural resources, the environment, increase of technogenic danger though technological innovations, etc.). In such a way, Russia and its regions should develop on the principals of sustainable development.

### References

- [1] Borodin, P.: Great transport future, Izvestiya, 2009.
- [2] Lvov, D.S., Moiseev, N.N.: Russia is in search of the third way. 2001 landmarks, State of Russia in the surrounding world: 1999, Analitical Series, eds. N.N. Moiseev, S.A. Stepanov, N.N. Marfenin, Moscow, 1999.
- [3] World in figures-2005, Vade mecum, Russian version, Moscow, 2005.
- [4] World in figures-2009, Vade mecum, Russian version, Moscow, 2009.
- [5] Neratov, D.: Second wind of Transsib, Soyuznoe Veche, Moscow, 2009.
- [6] The World Bank report about global competitiveness 2009-2010, Moscow, 2009.
- [7] State of Russia in the surrounding world: 2002, Analitical Series, eds. N.N. Moiseev, S.A. Stepanov, N.N. Marfenin, Moscow, 2002.
- [8] Latsa, A.: European future is Russia, <http://inosmi.ru/text/translation/253324.html>.
- [9] Russia in figures-2005, Moscow, 2005



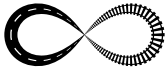

## USING RAILWAY SIMULATION AS A BASIS FOR INFRASTRUCTURE PLANNING – FOCUSING ON STRUCTURAL CHANGES AT TRAIN STATION EXITS

Katalin Jurecka

*Vienna University of Technology, Institute of Transportation, Austria*

### Abstract

Railway simulation is a powerful tool for answering numerous questions in railway network planning and analysing. The aim of this article is to show the importance of railway simulation used for analysing different design solutions. Special focus in this article is given to the gradient design of existing train station exits. The main question is, whether structural changes result in a significant advantage in running time and capacity, compared to the existing track. The results of the simulation shall confirm the expected anticipation that can be applied in future railway route design. Without running a simulation it is not possible to prove the assumptions before investing huge amounts into the infrastructure.

To perform the simulation, a graph model of a typical train station exit was developed based on a real case study in co-operation with Austrian Federal Railways (ÖBB), using the software programme OpenTrack (by OpenTrack Railway Technology Ltd., Switzerland). OpenTrack has three input components: infrastructure, rolling stock and timetable. All these three components varied to various test gradients, freight trains and operation modes in order to identify the most suitable gradient transition form out of different variants. The results show that depending on the operation mode and the position of the signals, opposing variants have to be preferred although there are only minor differences in running time between the structural variants. In conclusion, railway simulation is a suitable method to compare different variants and especially in this case a study to confirm the expected results.

*Keywords: railway simulation, gradient design, running time analysis, minimum headway time, maximum drawbar force*

### 1 Introduction

Gradient design is an important part of the railway route study. The focus of this article is on the gradient design of existing railway tracks, especially of existing train station exits. The results shall be applied in future railway route design. The main question is, whether structural changes can lead to a substantial advantage in running time compared to the existing track. Therefore, a simulation model of a train station exit has been developed, based on a real case study in co-operation with Austrian Federal Railways (ÖBB).

## 2 Simulation model

### 2.1 Infrastructure

The analysed structural changes are shown in Fig. 1. The figure presents the existing track (variant B), as well as two new tracks based on structural changes (variant A and C). The analysed section has a length of 11,1 km. The end of the station area is both: the position of the exit signal and the position of the first gradient change. The length shown in Fig. 1 and the positioning of the signals are based on the formerly mentioned real case study. The influence of the lengths has been examined as part of a sensitivity analysis.

The model of the train station exit has two characteristic gradients. One is the gradient in the station and one is that on the free track. The gradient in the station area is fixed throughout all simulation runs with 3 ‰. For the free track, five different gradients have been chosen. These gradients represent the inclination of different mountain railway lines and vary from 8,5 ‰ to 26 ‰. In Austria, for the construction of new railway lines the gradient is limited at 8 ‰ but can be exceeded according to the infrastructure operator [1]. Existing main railway tracks in Austria have gradients up to 31 ‰ [5]. In sections, the largest gradient used in this simulation is 28 ‰.

In this article, particular attention is given to the gradient of 10 ‰. The four other gradients (8,5 – 12,5 – 18,0 – 26,0 ‰) have been examined [4], but the results are not shown in this article, as there is no significant difference to the results of the chosen gradient. The gradient difference between the variants A, B and C is set as 2 ‰. The influence of the altered gradients has also been examined as part of the sensitivity analysis.

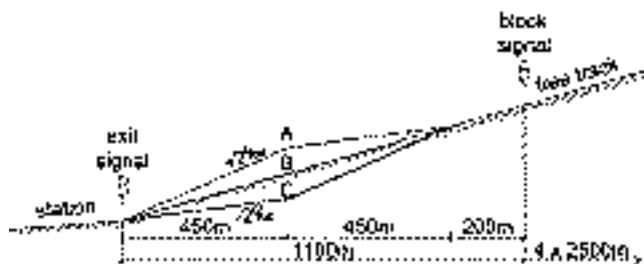

Figure 1 Train station exit in the longitudinal section

### 2.2 Rolling stock

For this simulation, three different freight trains have been selected. All selected freight trains have the same type of locomotive with the technical characteristics listed [4], but are not shown here. The freight trains differ in their trailer load. Therefore, the number of locomotives used depends on the trailer load, the gradient and operational rules from ÖBB. In this model, the freight trains have up to two locomotives. The length of the freight trains depends on the trailer load as well. Table 1 gives the trailer length using an average trailer load of 4 tons per meter.

Fig. 2 shows the tractive effort/speed diagram for the selected locomotive in case of single as well as double traction. For double traction the maximum drawbar force is the limiting factor, with a maximum drawbar force of 450 kN due to restrictions given by the infrastructure manager.

**Table 1** Characteristic values of the chosen freight trains and schedule

freight train name	number of locomotives	trailer load	trailer length	departure time station A [hh:mm]
F.1.1000	1	1000 t	250 m	08:00
F.1.1600	1	1600 t	400 m	08:10
F.2.2000	2	2000t	500 m	08:30

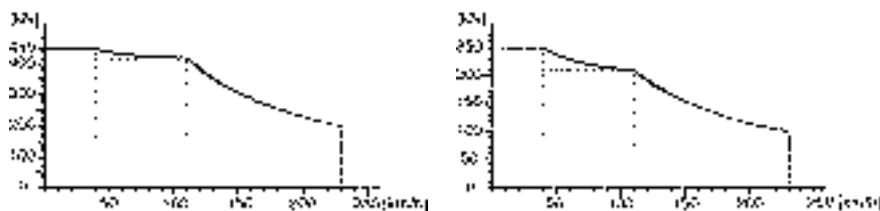

**Figure 2** Tractive effort/speed diagrams: single traction (left), double traction (right)

### 2.3 Timetable

The freight trains operate according to the schedule. They depart at station A one after the other at fixed times. However, the differences in time between the departures are not given by minimum headway times, but are only set to make sure that the trains do not influence each other. The trains have no stop at station B, therefore there is no set arrival time.

### 2.4 Simulation

In order to evaluate the influence of structural changes on the running time, a simulation has been carried out. The simulation has been performed by using the software programme OpenTrack. All data on infrastructure, rolling stock and timetable is defined by the user and is processed in the software programme. The software programme calculates the train movement per second, e.g. acceleration, speed, traction and resistance [3]. At gradient transitions, the software programme calculates the average gradient over the length of the train. Finally, different diagrams can be displayed by the software to evaluate the results of the simulation – e.g. distance/time, speed/distance, and acceleration/distance.

Each freight train is examined in three different operating modes that are as followed:

- 1 The train starts at station A and drives towards station B.
- 2 The train starts at station A and has an unscheduled stop at first block signal and then continues towards station B. This only occurs if a previous train reserves the second block.
- 3 The train passes through station A towards station B.

The influence of the chosen length on the results is examined as part of the sensitivity analysis. For this reason, both the values of length and the gradient difference between the variants A, B and C have been doubled.

### 3 Results

For each operation mode, the following diagrams display the results in the figures below:

- distance/time
- speed/distance
- running time
- minimum headway time

#### 3.1 Operation mode 1: starting

All freight trains start at station A and accelerate unlimitedly until they reach either the maximum track speed or the end of the track (Fig. 3). At the gradient transitions (variants A, B and C), the difference in speed is displayed but at the end of the track there are only minor differences in speed (less than 1 km/h).

The running times of the different freight trains roughly vary from 9 to 13 minutes (Fig. 4). The shortest running times can be achieved in variant c. The difference in running time between variant A, B and c is only in the range of seconds.

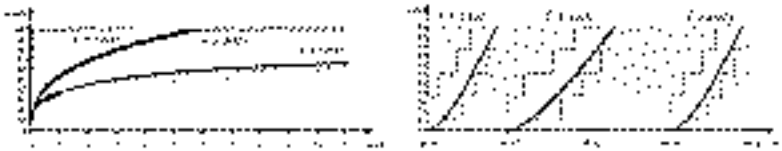

Figure 3 Speed/distance diagram (left) and distance/time diagram (right) for operation mode 1

The minimum headway times depend on the release time of the block signal at km 3,6 – that is the position of the second block signal on the free track. Fig. 3 shows the distance/time diagram with the blocking time stairway that represents the operational usage of the railway track. The blocking time ends after the train has left the section and all signalling appliances have been reset to normal position [2].

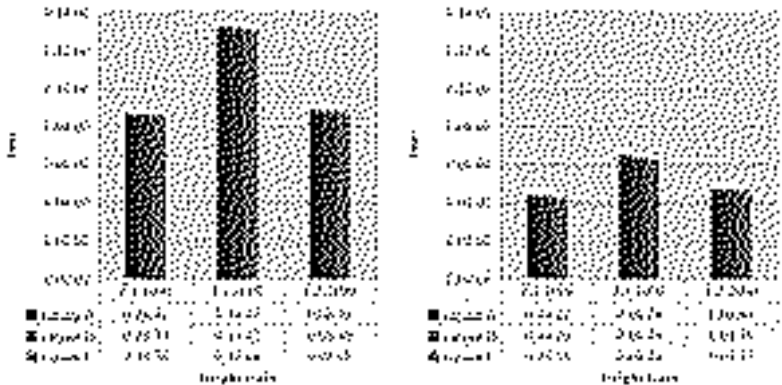

Figure 4 Running times (left) and minimum headway time (right) for operation mode 1

#### 3.2 Operation mode 2: stop at first signal

In this operation mode, all freight trains start at station A and accelerate until they need to stop at the first block signal. After the stop, the trains start at a specified time and accelerate again until they either reach the maximum track speed or the end of the track (Fig. 5). At the

end of the track, there are only minor differences in speed between the variants A, B and C (less than 1 km/h).

The running times of different freight trains roughly vary from 11 to 17 minutes (Fig. 6). The duration of the stop is not relevant and therefore not included in these results. On one hand, the shortest running times before the stop can be achieved in variant c. On the other hand, the shortest running times after the stop can be achieved in variant A. Because the differences between variant A, B and c, in these two sections, are only in the range of seconds the data is not shown in detail. Fig. 6 shows the sum of the running times of both sections. Both together, variant c is the fastest for the freight train F.1.1000 whereas variant A is the fastest for the other two freight trains. The difference in running time between variant A, B and c is only in the range of seconds.

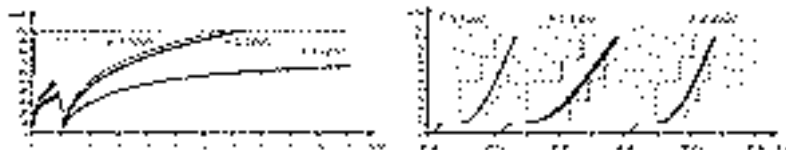

Figure 5 Speed/distance diagram (left) and distance/time diagram (right) for operation mode 2

The minimum headway times depend on the release time of the block signal at km 3,6. A train that has no stop at the signal follows the train that stops at the first block signal. Fig. 6 shows, that the minimum headway times vary from 4 to 6 minutes. The shortest minimum headway times can be achieved in variant c. The differences in minimum headway time between variant A, B and c are only in the range of seconds.

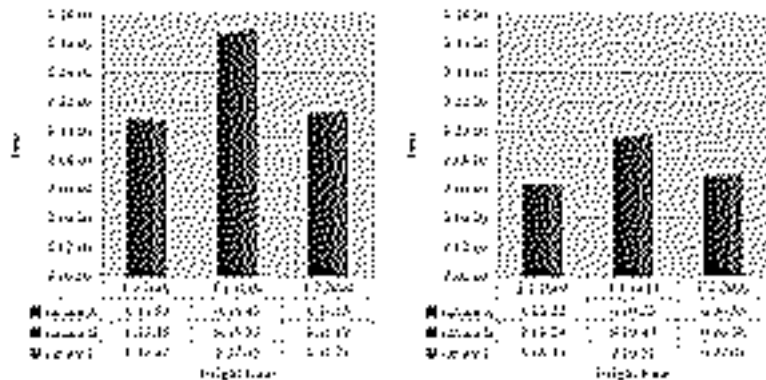

Figure 6 Running times (left) and minimum headway time (right) for operation mode 2

### 3.3 Operation mode 3: pass-through

In this operation mode, all freight trains enter station A on the main track with the maximum track speed of 100 km/h. For the freight trains F.1.1000 and F.2.2000, there is no difference between variant A, B and c because they can hold the maximum track speed. Whereas the freight train F.1.1600 is not able to hold the maximum track speed and continuously slows down (Fig. 7). At the end of the track, for the train F.1.1600 there are only minor differences in speed between the variants A, B and c (less than 1 km/h).

The running times of the different freight trains vary from 06:40 to roughly 07:30 minutes (Fig. 8). The shortest running times can be achieved in variant A. The difference in running time between variant A, B and c is only in the range of seconds.



The minimum headway times depend on the release time of the block signal at km 3,6. The train that passes through station A is followed by a train that starts at the exit signal from the sidetrack. Fig. 8 shows, that the minimum headway times are roughly 2,5 minutes. The differences in minimum headway time between variant A, B and c are only in the range of seconds.

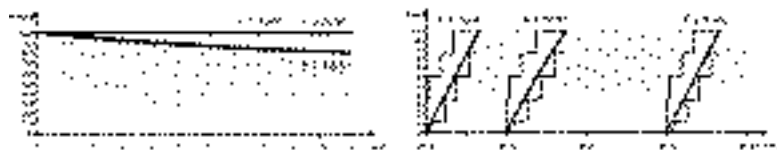

Figure 7 Speed/distance diagram (left) and distance/time diagram (right) for operation mode 3

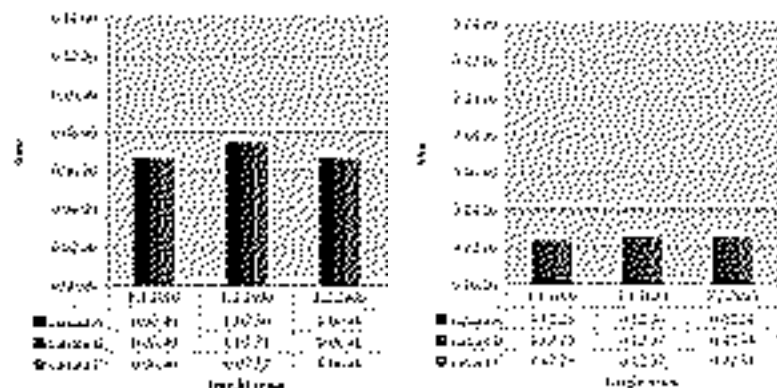

Figure 8 Running times (left) and minimum headway time (right) for operation mode 3

### 3.4 Sensitivity analysis and energy consumption

A sensitivity analysis has been performed to examine the influence of the values of length and of the altered gradient on the result. For this reason, both the values of length and the gradient difference between the variants A, B and c are doubled. The sensitivity analysis is conducted only for operation mode 1.

The freight trains run similarly to the result of operation mode 1. The running times differ from the result of operation mode 1 only in seconds. Therefore, the results are not shown in detail. As with operation mode 1, the shortest running times can be achieved in variant c. Furthermore, the differences in running time between variant A, B and c are still only in the range of seconds. Because there is no significant difference to operation mode 1, the minimum headway times are not shown.

As the results of the simulation show only minor differences in running time and speed, it can be assumed that there are also only minor differences in the energy consumption. The results of the simulation confirm this assumption, based on the calculated energy consumption of each course by the simulation software.

## 4 Discussion

The results show that depending on the operation mode, different structural variants have to be preferred. For example, the results for operation mode 1 are in contrast to the results for operation mode 2. For operation mode 1, variant A provides the shortest running times. Whereas, for operation mode 2, shortest running times are provided by the variant c. For this operation mode, it is important to consider the position of the first block signal. In this example, the length between the last gradient change and the first block signal is shorter than the lengths of the freight trains. That means that the freight trains are standing on the gradient change while they are waiting at the block signal. In this case, the software program calculates the average gradient over the train length. So for operation mode 2, the shortest running times after the stop are provided at variant A because this variant has the lowest gradient in this section. For this operation mode, variant c would only provide the shortest running times if the signal position would be changed according to the train length.

The results of the freight train F.1.1000 are related to the results of the freight train F.2.2000. This is because, for the freight train F.2.2000 both the load and the number of locomotives of the freight train F.1.1000 are doubled. But due to the limit for the maximum drawbar force for double traction at 450 kN, the freight train F.2.2000 cannot use the entire traction power provided by the engines.

## 5 Conclusions

The results can be summarised as follows: There are differences in running time and speed between the three variants, but these are only minor differences. The results clearly show that depending on the operation mode, different structural variants have to be preferred. Also the position of the signals has an essential impact on the results. As a consequence, the interaction between railway line design and operation is important and should be considered in the design process.

Generally, an unscheduled stop on the free track should be avoided – especially a stop in a section with a rather steep gradient. This can be done by application of a train control system that displays not only the maximum track speed but also the recommended track speed for the following block section.

The results show that variant A is the best variant not only for operation mode 1 but also for operation mode 2 if the signal position is changed respectively. To conclude, the existing variant is still a rather good solution if the quality of operation cannot be guaranteed.

## References

- [1] ÖBB, Richtlinien für das Entwerfen von Bahnanlagen (HL-Richtlinien), point 6.8.1, 2002, in German.
- [2] Hansen, I.A. [Ed.], Railway Timetable & Traffic, Eurailpress, Hamburg, p. 19ff, 2008
- [3] Hürlimann, D., Objektorientierte Modellierung von Infrastrukturelementen und Betriebsvorgängen im Eisenbahnwesen, Dissertation, ETH Zürich, Zürich, p. 85, 2001, in German.
- [4] Jurecka, K., Fahr-dynamische Optimierung von Bahnhofs-ausfahrten im Längenschnitt, Master's Thesis, Vienna University of Technology, Vienna, 2010, in German.
- [5] Kopp, E., Möglichkeiten und Grenzen der Linienverbesserung von Gebirgsbahnen, ETR – Eisenbahntechnische Rundschau (53), 2004, Nr. H. 7/8 July/August, p.439-446, in German.



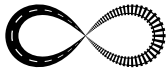

## COMPARATIVE ANALYSIS OF ALTERNATIVE FIXED TRACK TECHNOLOGIES FOR THESSALONIKI AIR–LINK CONNECTION

Panagiotis Papaioannou<sup>1</sup>, Alexandros Deloukas<sup>2</sup>, Ioannis Politis<sup>3</sup>, Manos Vougioukas<sup>4</sup>

<sup>1</sup> Thessaloniki Public Transport Authority, Greece

<sup>2</sup> ATTIKO METRO SA

<sup>3</sup> Aristotle University of Thessaloniki, Greece

<sup>4</sup> Eurotrans Consulting Ltd, Greece

### Abstract

The International Airport of Thessaloniki is the third busiest airport in Greece, serving over 4 million passengers annually. A significant upgrade in terms of capacity is foreseen according to its master plan for year 2030. Expected travellers may reach double figures by then. This increase calls for an improved and more reliable city–airport connection for the future. Three alternatives to the existing bus connection are examined; a further extension of the Metro at–grade which is under construction, a segregated Tramway/LRT, and an elevated Monorail. The new fixed track corridor under consideration will consist of 5 stations and will have a total length of 5.1 kms. The modal operating capacity selected, covers 10 min policy headway, a 25% rail transit share of the total trips and a directed loading of 1,300 passengers per hour per direction (pphd).

A comprehensive multi modal transport model, developed by Thessaloniki Urban Transport Authority, was used as a supplementary tool, in order to perform extended cost/benefit comparative analysis. The investigation of cost (e.g. operating cost, user cost, rolling stock and infrastructure) and benefit (e.g. time variability risk, novelty image, employment creation) elements, indicate that Monorail is likely to be the least costly and most beneficial rail alternative in a total cost (benefit) perspective. The final decision however depends on both availability of funds and future expansion potential of each alternative.

*Keywords: rail technologies, fixed route systems, cost benefit analysis*

### 1 Introduction

The international airport of Thessaloniki 'Macedonia' is the third busiest airport in Greece, serving over 4 million passengers annually. The airport serves local and international flights mainly to European countries and operates on a 24 hour basis. Some 27 scheduled airlines were served in 2011. In addition 21 chartered flights were served during the summer period. 'Macedonia' airport plays a significant role in the network of south–eastern Mediterranean airports and has major future growth prospects, in Eastern Europe, the Balkans and the Black Sea. The airport upgrading works (runway extensions etc.) are in the implementation phase and progress rapidly. In the final phase of operation, the airport will have 2 complete and modern runways and will be able to meet the demand of approximately 8 million passengers per year.

This improvement actually calls for improved and more reliable connections between the airport and the city as well as the surrounding areas. This paper presents the methodology and the results of the comparative examination of three alternatives to the existing bus connec-

tion comprising; a further extension of the Metro at-grade which is under construction, a segregated Tramway/LRT which will start from the Metro terminal station, and an elevated Monorail instead of the Tram/LRT. All alternatives are not only time reliable but also electrified, so their use is air-pollution free and carbon neutral. The rubber-tired technologies investigated are almost free of noise nuisance. The examination took place in the framework of a CIVITAS CATALIST project completed in 2011 [1], [2]

## 2 Airport and City link Transport and Traffic data

### 2.1 Airport Transport Data

Thessaloniki airport serves approximately 4 million passengers (arriving and departing) every year. Passenger demand increases significantly during summer months. However intercontinental flights cannot be served due to the short length of the two runways. The extension of runway 10–28, which is under way, will enable intercontinental flights to land and take off from Macedonia' airport increasing in this way significantly the passenger volumes in the future. Air travellers in August which is the heaviest month correspond to 15.4% of annual passengers. Figure 1 left shows the seasonal variation of airport users for years 2009 and 2010 for both regular and chartered flights.

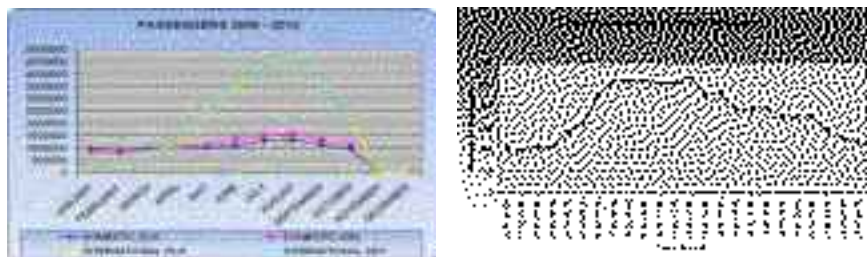

**Figure 1** Left: seasonal variation of the different passenger categories; Right: daily accumulation of airport employees

Along with travellers a large number of escorts and airport employees travel to and from the airport. Escorts, according to recent surveys in Athens International Airport [3], account for 10% of air travellers. By taking also into account that for those escorted 1.5 persons in average escort one traveller, it was made possible to estimate number of escort trips. With respect to employees, their number varies between 1125 in winter and 1800 in summer time. During the year some 2,600 commuter trips/day are made from which 75% by car and 25% by PT bus. Figure 1 right presents the daily accumulation of airport employees in a typical day.

### 2.2 Current Airport Link

Thessaloniki airport is currently linked to Thessaloniki city and the rest of the hinterland only through the existing main highway network. Passengers can access the airport either by private cars and taxis or by public transport (buses). The airport offers three parking facilities able to accommodate up to 1322 vehicles from which 170 for short term parking and the rest for long term parking. Two bus lines serve the airport; the first reaches Thessaloniki city centre and the second a nearby bus-terminal station from where travellers can use other bus lines towards the city centre. The departure frequency is 30 min for each line during winter period and almost doubled during summer periods. A night line also operates all year long. The distance between the airport and Thessaloniki city centre is 14 km and it takes in average 35–45 min by car & taxi and 55–75 min by bus (Figure 2).



**Figure 2** Location of Thessaloniki airport relative to the city

Based on automatic traffic counts, detailed private car and bus passenger counts during a typical week in April 2011 and finally on air traveller arrival and departure observations in the same time period as well as on employee trip characteristics survey, it was made possible to calculate the modal split of all trips from and to the airport for the different categories of trip makers. The above results were expanded to annual basis taking into account overall passenger and employee variations within the last two years (2009–2010). Tables 1 and 2 present the daily modal split figures for all trip makers in absolute and % terms and the % share of all different categories on an annual basis.

**Table 1** Overall modal split of trip makers to and from the airport

Mode	Vehicle Occupancy	Person trips	MS
Taxi	1,5	1850	17%
Bus	20%	1960	18%
Car	1,6	6920	65%
Total		10730	100%

**Table 2** Annual person trips per segment of airport population 2011

Segment	Person trips	% share
Air travellers	4 mil	70%
Escorts	1.15 mil	20%
Employees	0.65 mil	10%
Total	5.8 mil	100%

### 3 Alternative future links to Thessaloniki airport

#### 3.1 Description of alternative fixed track systems and methodology used

Three main alternative connections between Thessaloniki airport and the city future Public Transport network were examined; (a) a further extension of the Metro at-grade which is under construction, and it will terminate at Mikra station located at the eastern part of Thessaloniki conurbation, some 5 km away from the airport; (b) a segregated Tramway/LRT, which will start from Mikra terminal station and will end at the airport; (c) an elevated Monorail connecting the same two terminal points. For passengers travelling from Thessaloniki city area, all but metro alternatives would require a transfer at the terminal metro station, properly designed to reduce the pertaining inconvenience. The new fixed track corridor under consideration will consist of 5 stations and will have a total length of 5.1 km (Figure 3). Estimations of passenger demand at the intermediate stations of the connection were made by means of a land use inventory, subsequent trip generation calculations and the use of a transport planning model built exclusively for this consideration [4]. The modal operating capacity selected, covers 10 min policy headway, a 25% rail transit share and a directed loading of 1,300 pphpd.

A comparative analysis of the above three systems was performed using the two staged approach of the World Bank [5] as refined later in 2001 [6]. According to this methodology in the first stage non cost attributes of the modal options are considered; most adequate systems will come out from this exercise considering also the demand and supply elements in each specific option. In the second stage the choice of the most suitable mass transit technology will be made in terms of the total costs, namely user costs, operator's cost and community (social) costs. All alternative options were compared against an improved future bus connection starting from the Mikra terminal station.

In this specific case, capital costs among the three alternatives differ significantly as it is the case for the operating costs. The Metro alternative bears high capital and expropriation costs as well as operating costs. Buses on the opposite side are linked with high operating costs and low capital costs. On the other hand metro bears high benefits to its users, especially because there will be no need for transfer from one PT mode to another. LRT and monorail lie in between.



Figure 3 Proposed new Rail–Air Link with intermediate stops

### 3.2 System, User and Community Costs

Costs examined within the comparative analysis performed, include three main categories, Operator's costs, User costs and Community costs. Operator's costs can be further broken down into capital costs (Rolling Stock, Land, Infrastructure, Electromechanical, Depots, Overheads) and Operating Cost (Staff, Energy, Materials, Outsourcing, Overheads). User costs consist of Time cost (linked to value of time), In-vehicle journey time cost, Transfer penalty costs and Travel variability risk. Finally a mode specific cost (benefit) expressed as Novelty image was also included in the analysis. Community costs consist of Employment costs, Land acquisition costs, and Climate related costs. Table 3 presents in summary the comparison of the 3 fixed track alternatives and the improved bus connection option.

### 3.3 Stated Choice Experiment

A state choice experiment using a special questionnaire form was conducted in April 2011 at the airport, in order to capture attitudes and preferences of all type of travellers to and from the airport. Specific questions about the three alternative future fixed track systems were included in the questionnaire form. In total 500 valid questionnaires were collected from five discrete segments, namely Greek domestic travellers, Greek international travellers, foreign travellers, escorts and employees. Trip characteristics of travellers were also gathered. A number of different criteria with respect to the most attractive mode to the questioned were set. Table 4 presents the responses of all persons in the sample to those criteria.

**Table 3** Main characteristics of alternative Airport Connection options

Scenario		A	B	C	D
System		Metro (3 cars)	Tram /LRT	Monorail (6 cars)	Bus
Route Length	m	5100	5100	5100	6300
Car Capacity	pax	150	200	34	150
Transit Unit Capacity	pax	450	200	204	150
Max design capacity	pphpd	10800	4000	1300	900
Max speed	km/h	80	70	80	80
Commercial speed	km/h	32	25	40	21–35
In-Vehicle Journey Time	min	10	13	8	15
Scenario		A	B	C	D
Transfer Time (Mikra)	min	0	1	3	3
Walk Time / Egress Time	min	3	3	3	3
Transfer Penalty (Mikra)	min	0	1	3	3
Policy Headway	min	10	10	10	10
Novelty Image	(-) min	1	1	2	0
Minimum Layover Time	min	2,5	2,5	1,5	10
Number of transit units p.h.	no	4	5	2	6
Capital Cost	K€	126,777	78,239	95,567	3,600
Operating Cost	K€	4,200	3,300	4,000	2,200
Land Cost	K€	4,000	2,900	525	0



**Table 4** Mode choice criteria per user group category

Criterion	Air Travellers	Escorts	Employees
Duration of the trip	92.6%	92.0%	98.0%
Cost of the trip	90.0%	91.0%	93.0%
Minimization of transits	89.6%	88.0%	91.0%
Comfort	82.0%	79.0%	87.0%
Reliability	95.6%	93.0%	97.0%

By using the related behavioural characteristics obtained from the state choice experiment per scenario examined, it was made possible to construct 3 transport planning models, one per alternative. In addition two more models were build, one for the existing bus connection (Do\_Min) and one for an improved bus connection, starting from MIKRA terminal station every 10 min (Do\_Min\_B). The outputs of the model runs for horizon 2016 in terms of peak hour maximum passenger load per direction for the heaviest sections are shown in Table 5. From these results it can be seen that the Metro option attracts the highest passenger load, whilst the monorail comes second. The improved future bus connection comes very close to the monorail option.

**Table 5** Projected peak hour max. Passenger load per Scenario (2016)

Scenario	Direction	Max Passenger Load ph	Segment
A	From Airport	976	ZEDA-MIKRA
	To Airport	617	MIKRA-ZEDA
B	From Airport	456	ZEDA-MIKRA
	To Airport	273	MIKRA-ZEDA
C	From Airport	662	ZEDA-MIKRA
	To Airport	380	MIKRA-ZEDA
Do_Min	From Airport	63	KRIKELA-25HS MARTIOY
	To Airport	235	FALIRO-SXOLI TIFLON
Do_Min_B	From Airport	657	IKEA-SASTH-VIAMIL
	To Airport	169	EMPORIKO KENDRO-POLYFOTA

## 4 Comparative Analysis results and Conclusions

The results of the comparative analysis performed among the three fixed track alternatives and the future improved bus connection in terms of total implementation and operating costs are shown in Table 6. It should be stressed that the bus option refers to a link from Mikra terminal station to the airport and vice versa and not to a direct link from/to Thessaloniki city centre.

All costs were annualised in order to allow for a direct comparison. Transit investments assumed to be made by a 30 year loan with an interest rate of 8%. Annual payments cover both principal and interest. Targeted passenger demand is achieved in 2030, whilst in 2016 the lower demand is satisfied at a reduced cost by longer headways. For the metro option, land expropriations are necessary whilst for the tram system the respective needs are smaller. The monorail does not require any expropriations. In addition Tram/LRT and monorail require space for a depot which depends on the 'future' number of transit units. There is no such a need for the metro since a depot will be available from the main metro line. Regarding ope-

rating cost of each system a detailed cost calculation was made. The same figure applies to energy consumption, spare parts needs and other outsourcing costs. Finally, an average farebox revenue of 2€ for rail alternatives, and 1€ for bus, was assumed as a 100% operating cost recovery.

The summary findings presented in Table 6 indicate that the alternatives examined do not differ significantly in terms of total cost. The bus, as expected is the cheapest one, but it does not secure in the future an adequate level of service. Furthermore, it is more vulnerable to congestion conditions as well as to unexpected events. Monorail seems to be the cheapest option among the fixed track ones and most easy to implement. However, it is lacking potential for extension, something that may be proven necessary given the development in the areas beyond the airport. The Tram/LRT is the least preferred option, given that it is the most expensive after the Metro and at the same time it is associated with many other disadvantages such as need for land space, interaction with traffic and need for a new depot. The Metro on the other hand is associated with many advantages but at the same time is the most expensive and time consuming with a very high capacity reserve (low utilization rate). The final dimension needed to be taken into account is the potential for development in the area along the fixed track and the possible gains in land value. Such gains can partially finance implementation and operation of the air–rail link. This is not possible in case of maintaining the bus connection.

**Table 6** Total cost per alternative mode

Mass Transit Technology	Metro	Tram/ LRT	Mono-rail	Do_Min_B (Bus)
<b>User Costs</b>				
In Vehicle Journey Time Costs	8.900	11.360	7.380	10.870
Transfer Penalty Costs ('Mikra' terminal)	0	1.142	3.125	3.125
Cost of Travel Time Variability (Risk) approaching the Airport	0	0	0	3.588
Novelty Image Cost (benefit)	-1.168	-1.168	-2.337	0
Sum User Costs	7.732	11.334	8.168	17.583
<b>Operator's Costs</b>				
Capital Costs (8%, 30y.)	11.261	6.950	8.489	320
Operating Costs	4.200	3.300	4.000	2.200
Sum Operators' Costs	15.461	10.250	12.489	2.520
<b>Community Costs</b>				
Employment Costs (benefits)	-346	-302	-317	-223
Land Acquisition Costs (4%, 30y.)	231	168	30	0
Climate Cost (benefit)	0	0	-70	0
Sum Community Costs	-115	-134	-357	-223
SUM Total Costs (000) (annualized 2011 prices)	23.078	21.450	20.300	19.880

## References

- [1] Thessaloniki Public Transport Authority, Connection of Thessaloniki International 'Macedonia' Airport with future fixed track rapid system network of Thessaloniki, Project co-funded by the EU CIVITAS CATALIST Programme Feasibility Report, Greece, 2011
- [2] Thessaloniki Public Transport Authority, Connection of Thessaloniki International 'Macedonia' Airport with future fixed track rapid system network of Thessaloniki, Project co-funded by the EU CIVITAS CATALIST Programme , Stated Choice Survey Report, Greece, June 2011
- [3] Athens International Airport, AIA 2003 Passenger and Employee Survey, Greece, 2004
- [4] Thessaloniki Public Transport Authority, Greater Thessaloniki Area Transport Planning Model for the Metro extension to Kalamaria, Technical Report, 2011
- [5] Armstrong-Wright Alan, Urban transit systems: Guidelines for examining options World Bank Volume/ Edition 52, Washington D.C.1986.
- [6] Parajuli P., Wirasinghe S., A Line Haul Transit Technology Selection Model, Transportation Planning & Technology, Vol 24, 2001 pp. 271-308

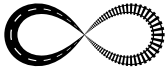

## AIRPORT ACCESS INFRASTRUCTURE CRITICAL ISSUE OF THE INTERMODAL CHAIN

**Antonín Kazda**

*University of Žilina, Air Transport Department, Slovakia*

### Abstract

Attractiveness of an airport depends not only on the number of routes offered but also on the airport access infrastructure and airport terminal capacity. The expected passenger growth in 2030+ time horizon is tremendous and it is not only necessary to fly them, but also to get all passengers, meeters and greeters and staff to and from the airports. Quality of airport access, the trip duration and the reliability of the access mode influence the passenger decisions for particular airport selection but also airport arrivals and dwell times in the terminal which can have a dramatic effect on airport operators, their retail models and ultimately their revenue. With respect to the passenger typology it is important to focus also on the low cost carriers segment which will represent 30% of the whole market in 2026 in Europe. The ambition of most European airports is to increase share of public transport in the airport access modes to reduce large environmental footprint resulting from share of drop off 'kiss and fly' traffic with negative impact on the environment and the access road capacity. However, is it possible to increase attractiveness of intermodal transport in the future? What are the preferences of different categories of passengers? Is it possible that dedicated rail services could be attractive also for the price sensitive segment of low cost passengers? Results from research at Prague, Brno and Bratislava airports but also from other sources give answers to these questions.

### 1 Introduction

The simple, smooth growth curves that are often seen in air traffic forecasts can encourage us to plan simplistically, but demand is not homogenous in all world regions and traffic growth is not uniform. The dips in growth of passenger growth are related to the oil crises in 70's and 80's, the recovery in the following years, the drop after 11 September 2001 and growth restored thereafter [6]. However, air transport development is intrinsically linked to economic growth and the long term average records about 5% increase per year over 20 years [4] despite different crises and other short-term market depressions.

The analysis of future trends in all world regions shows that Asia and North America will be together with Europe dominating the world air transport market after 2025. According to Boeing: Current Market Outlook 2011–2030 the world GDP is expected to grow by 3.1% annually between 2011 and 2028. However, it will not be equally distributed around the whole world. For example, Chinese GDP is now expected to grow by 10.4% and Indian GDP by 8.4% annually by 2028 [1]. This will result in very strong growth of air transport in Asia in the next two decades comparable with that in the West, which will result in the doubling of air traffic every 20 years.

According to [2] after examining the more than 160 traffic flows the projected annual growth expressed in revenue passenger kilometres (RPK) of 4.84% (rounded to 4.8%) from 2010 to 2030 is expected. Similarly according to [4] growth of 5.1% annually for the same period is expected.

Passenger numbers will increase but fortunately, for the runway and airspace capacity, the number of aircraft movements will not rise as fast because of higher load factors, less frequency and new bigger aircraft.

Short haul transport will be increasingly characterised by low cost carriers. Airbus expects low cost carriers to continue to increase their global short-haul traffic market share, from 23% today, up to 29% by 2020 and 34% by 2030. Regionally, some short-haul markets such as the intra Western Europe or domestic ASEAN for instance are expected to have greater low cost market presence, potentially taking a 60% share of the short-haul market on these flows by 2030 [2].

This market will grow on average by more than 6% annually [4] and the market share (in terms of seats) of Low Cost Carriers (LCC) will achieve high values by 2026 [2] see Table 1.

**Table 1** Market share of the Low Cost Carriers in 2026

Region	Market share [%]
Europe	30
North America	23
Latin America	20
Asia	12

## 2 Airport access and airport terminal capacity

Doubling the number of passengers by 2028 does not necessarily mean that duplicating infrastructure will be required to accommodate the demand [19]. With respect to airside and airspace capacity, implementation of new control tools and management measures will contribute considerably to better utilisation of existing infrastructure e.g. CDM, AMAN, DMAN, ACE. Despite the absence of essential investments such as new runways or terminal buildings, the Europe's most congested airports still keep their ability to accommodate the growing demand. Needless to say these airports have been considered as saturated for years [20]. In Europe there are measures proposed to increase and better utilize the air transport capacities.

The expected passenger growth in 2030+ time horizon is tremendous and it is not only necessary to fly them, but also to get all passengers, meeters and greeters and staff to and from the airports. All of above listed methods for air transport capacity enhancement consider air transport as an isolated and independent transportation system and the problems of airport terminals and airport ground access are being underestimated [19].

Many times airport managers object that ground transportation to and from the airport is not necessarily their business. They are right. But the quality of airport access, the trip duration and the reliability of the access mode influence the passenger decisions for particular airport selection but also airport arrivals and dwell times in the terminal which can have a dramatic effect on airport operators, their retail models and ultimately their revenue. The operation of a passenger terminal partly depends on the airport ground access, as the reliability of the access transport and the length of passenger journey affects the amount of time that the departing passenger spends in the terminal. Short dwell times in terminals require only few facilities while airport terminals where longer dwell times are expected must provide a high level of comfort and convenience. Ashford, Stanton and Moore [3] identified length of access time and reliability of access time as two of the most important factors influencing the departing dwell times.

We can approximate the time necessary for a particular access journey to an airport as a random variable that is normally distributed about its mean value. The real arrival earliness pattern of passengers differs from the normal distribution. The distribution for simulation of

departing passenger flows was researched and described by Mr. Maťaš and Dr. Štefánik who are the authors of the AGAP – Airport Ground Access and Egress Passenger Flow model. It is reasonable to assume that the variance of the individual journey time about the mean is in some way proportional to the mean.

The real arrival earliness distribution of passengers differs from the normal distribution and it is unique for each airport and mode of transport (Figure 1)[22].

The long queues at check-in counters and at security checkpoints are not the only issues the airport operators have to deal with. A large percentage of private vehicle access trips at many airports lead to congestion of airport access roads and car parks. Moreover, a high share of individual car access trips has a negative impact on the environment. At many airports the ground trips of private cars associated with the airport operation generate a greater share of air pollution than the aircraft movements [9]. The kiss-and-fly transport generates twice the number of car journeys compared with the passenger who uses an airport car park. In 2005, 27% of air travellers through Gatwick were driven to the airport in cars belonging to friends or family.

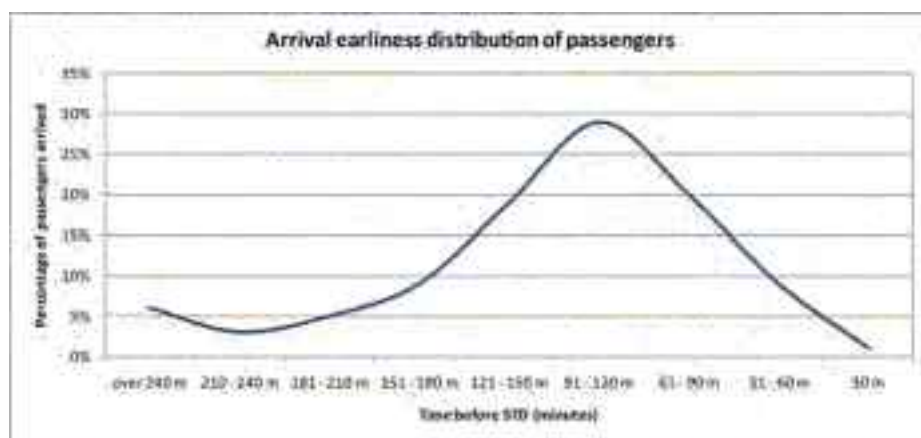

Figure 1 Arrival earliness distribution of passengers at LZIB [19] (Source: Bratislava M.R. Štefánik Airport passenger surveys 2003, 2004 and 2007)

### 3 Ground transportation and revenue issues

Airport access improvement leads to a stronger position of an airport on a market and to an enlargement of the airport catchment area. An increase in an airport's attractiveness also results in airport throughput development. On the other hand, access traffic improvement leads to a reduction of passenger dwell times which may imply limited time for shopping and spending in catering facilities which can affect airport non-aeronautical revenue. An increase of public transportation share may result in a decrease of individual car journeys and a car park income decrease.

## 4 Time and dedicated services

Our most valuable possession is not material wealth, it is our time – how we spend the limited hours of our lives [10]. Time is irrespective of the social status or the amount of cash. It is claimed that: 'People spend somewhat more than one hour per day travelling on average (i.e. travel time budget), despite widely differing transportation infrastructures, geographies, cultures and per capita income levels' [17]. The notion that a travel time budget is stable over time and space and independent of modes of travel is open to debate.

Mankind becomes wealthier. Most people feel that we have less time and it is only a reflection of reality. Life is more dynamic. As a consequence, we are using faster means of transport to increase our range in allowed time limits and travel time values tend to increase. As any transfer in a transportation chain implies time penalties, direct and faster services tend to be more expensive but also more preferable by passengers with higher income and social status. As an example, the transport between the Kuala Lumpur International Airport (KLIA) and the Kuala Lumpur city could be mentioned. When using KLIA Ekspres, the journey takes 28 minutes while the journey with KLIA Transit (commuter service with three quick stops at intermediate stations) takes 35 minutes. The ridership split between Ekspres/Transit is 36:64, while the revenue split is approximately 70:30, indicating the much higher yields of the Ekspres.

This raises the question – who could be the customers of direct – dedicated rail services? Logically most can come from business passengers because of the higher price of a direct service. This is not always true. Simply there are always passengers who will probably never ever use public transport and will keep driving a car (at the start of his/her journey) and/or taking a taxi in his/her destination or at both ends of journey. For a non-resident business traveller arriving for the first time to an unknown airport it is easier and more convenient to take a taxi and avoid a transfer in the city centre station or city terminal. On the way back, if she/he boards a taxi in front of the hotel it is likely that she/he will go directly to the airport or without a return ticket may at least vary the return to the airport. Vienna airport in cooperation with Vienna Tourist Information ventured to ease the city centre transfer problem by offering a single CAT – CAB ticket, with preferential tariff with internet booking. It could be used for special taxi transportation between a hotel and CAT train station and it also includes the train ticket between city centre and the airport.

## 5 Dedicated rail services and Low Cost Passengers preferences

The other question is if direct train services are also being used by the low cost passengers. According to [15] the typical LCC passenger is extremely price sensitive, intelligent and young. Conventional evaluation practices tend to ignore transport qualitative factors, assigning the same time value regardless of travel conditions, and so they undervalue service improvements that increase comfort and convenience.

Discretionary passengers (people who have the option of driving) tend to be particularly sensitive to service quality. Increase of a public transport quality often increase transit ridership and reduce automobile traffic [10]. Numerous studies have quantified and monetized (measured in monetary units) travel time costs by evaluating how travellers respond when faced with a trade-off between time and money, for example, when offered an option to pay extra for a faster trip ([13], [21], [11]). All factors of transport quality and comfort (level of service), waiting conditions, crowding, transfer, reliability, frequency, safety, security, real time travel information, speed and even aesthetics could be evaluated as they affect passenger decision for particular mode of transport.

The LCC passengers are extremely price sensitive, many times it is their first time in a particular location and thus they are unfamiliar with the usually complex local transportation system. On the other hand, LCC passengers would not risk missing a flight by choosing an access transport with a low reliability. The typical LCC point-to-point operation normally offers, with exception

of very dense markets, just one flight a day [23]. When missing a flight, the low cost passenger may need to bear the costs of an extra night accommodation and certainly will pay high price for a new last minute ticket. However, these issues affect outbound passengers only. Some passengers can look for cheaper alternatives after the inbound flights [24].

Onward travel (after arriving at destination) is mostly not demand derived and can be influenced. On arrival passengers usually have more options on how to get downtown. According to Stansted Express experience the choice of which type of onward travel can be controlled and influenced back at the time of flight booking (home/internet/ travel agent) but also at the airport before departure, during flight by onboard sales and finally on arrival. In the case of Stansted Express targeted marketing partially shifted passenger behaviour. This research, customer insight, and marketing communication and promotion with online links from airlines to Rail were major influencers in the incremental mode share improvements for Stansted Express during 2006–2008.

Results of our PhD research conducted on three European airports show that the most important factors for increasing public transport attractiveness for air passengers against car usage are mainly:

- Simple transfer between transport modes with minimum walking distances
- Possibility of single ticket usage
- Connections reliability

Considering all the above mentioned factors, LCC passengers may decide to choose direct train services to the airport if we offer him/her a product with high time values improvements. Fast, uncongested, clean, reliable, safe, secure, easy to plan, easy to use, easy to find, with a station directly at the airport terminal. The second part of the success is the easiness of booking, buying the ticket via Internet but also other selling channels in cooperation with airlines (on board sales) and the airport.

Note: 'This paper is published as one of the scientific outputs of the project: Centre of Excellence for Air Transport ITMS 26220120065'

## References

- [1] ACARE Advisory Council for Aeronautics Research in Europe: Aeronautics and Air Transport: Beyond Vision 2020 (Towards 2050); June 2010
- [2] Esveld, C.: Airbus: Global Market Forecast 2011 - 2030; <http://www.airbus.com/company/market/forecast/>; 11.2.2012.
- [3] Ashford, N., Stanton, H. P. M., Moore, C. A.: Airport Operations, Second Edition; McGraw-Hill; 1997
- [4] Boeing: Current Market Outlook 2011-2030; [http://www.boeing.com/commercial/cmo/pdf/Boeing\\_Current\\_Market\\_Outlook\\_2011\\_to\\_2030.pdf](http://www.boeing.com/commercial/cmo/pdf/Boeing_Current_Market_Outlook_2011_to_2030.pdf) ; 11.2.2012
- [5] Cohan, H., Southworth, F.: On the Measurement and Valuation of Travel Time Variability Due to Incidents on Freeways, Journal of Transportation and Statistics, 1999, [www.gcu.pdx.edu/download/2cohen.pdf](http://www.gcu.pdx.edu/download/2cohen.pdf), Dec. 1999, pp. 123-131, 26.8.2009
- [6] EUROCONTROL Long-Term Forecast: IFR Flight Movements 2010-2030; DAS/DIA/STATFOR Doc302; 11.2.2012; DAS/DIA STATFOR; EUROCONTROL Headquarters, 96 Rue de la Fusée, B-1130 BRUSSELS
- [7] Evered, A.: The Impact of New Security Measures on Airport Retailing in the UK; Airport International website ([www.airport-int.com](http://www.airport-int.com)); 2007, 11.2.2012
- [8] Hollander, Y.: Direct Versus Indirect Models For The Effects Of Unreliability, Transportation Research A, Vol. 40, Is. 9 ([www.elsevier.com/locate/tra](http://www.elsevier.com/locate/tra)), Nov. 2006, pp. 699-711, 26.8.2009
- [9] Kazda, A., Caves, R. E.: Airport Design and Operations, 2nd ed. - Amsterdam; Oxford: Elsevier, 2007. - 522 p. - ISBN 978-0-08-045104-6



- [10] Litman, T.A.: Valuing Transit Service Quality Improvements, Considering Comfort and Convenience in Transport Project Evaluation, Victoria Transport Policy Institute, 2008
- [11] Litman, T: 'Travel Time,' Transportation Cost and Benefit Analysis, Victoria Transport Policy Institute, 2007, ([www.vtpi.org](http://www.vtpi.org)); at [www.vtpi.org/tca/tca0502.pdf](http://www.vtpi.org/tca/tca0502.pdf); 11.2.2012
- [12] Lyons, G., Urry, J.: The use and value of travel time; unpublished paper; 2004
- [13] Mackie, P. et al.: Values of Travel Time Savings in the UK, Institute for Transport Studies, 2003, University of Leeds ([www.its.leeds.ac.uk](http://www.its.leeds.ac.uk)), U.K. Department for Transport, [www.dft.gov.uk/stellent/groups/dft\\_econappr/documents/page/dft\\_econappr\\_610340.hcsp](http://www.dft.gov.uk/stellent/groups/dft_econappr/documents/page/dft_econappr_610340.hcsp); 11.2.2012
- [14] Meehan, D.T.: Airports: Innovative Programs and Partnerships; SH&E International Air Transport Consultancy, May 18, 2005
- [15] Observatório Turismo de Lisboa: Lisbon Low-Cost Passenger Profile, Summer 2008; [http://www.atl-turismolisboa.pt/getdoc/15cf6db3-742e-45c8-93a4-5c94dd5dee3f/Lisbon-Low-Cost-Passenger-Profile\\_Summer-2008.aspx](http://www.atl-turismolisboa.pt/getdoc/15cf6db3-742e-45c8-93a4-5c94dd5dee3f/Lisbon-Low-Cost-Passenger-Profile_Summer-2008.aspx); 11.2.2012
- [16] Pilon N. and Brom L., Challenges in Air Transport 2030, survey of expert views (2007-2008), EUROCONTROL Experimental Centre, EEC Report n° 412, December 2008
- [17] Schafer, A.: The Global Demand for Motorized Mobility. *Transportation Research A*, 32(6), 455-477; 1998
- [18] Small, K.: et al, Valuation of Travel-Time Savings and Predictability in Congested Conditions for Highway User-Cost Estimation, 1999, NCHRP 431, TRB, [www.trb.org](http://www.trb.org) 10.2.2012
- [19] Štefánik, M.: Problems of Airport Capacity Assessment; doctoral thesis, University of Žilina, 2009
- [20] Tether, B. – Metcalfe, S: Horndal at Heathrow? Co-operation, Learning and Innovation: Investigating the Processes of Runway Capacity Creation at Europe's Most Congested Airports; The University of Manchester, UMIST; June 2001
- [21] Wardman, M: Public Transport Values of Time, *Transport Policy*, Vol. 11, No. 4, ([www.elsevier.com/locate/transpol](http://www.elsevier.com/locate/transpol)), Oct. 2004, pp. 363-377, 26.8.2009
- [22] Štefánik, M, Pekárová, S.: Optimizing Airport Terminal Facilities Utilization by Means of Controlling the Arrival Earliness Pattern of Passengers, *Transcom 2009*, 22-24 June 2009; University of Žilina, Žilina, Slovak Republic
- [23] Badánik, B, Štefánik, M.: The Problems of Daily Flight Schedule Extrapolation, *Transcom 2009*, 22-24 June 2009, University of Žilina, Žilina, Slovak Republic
- [24] Stansted Express co-operates closely with BAA Stansted to reduce the drop off/ Private car share known as 'Kiss & Fly' at Stansted which is estimated at 20% of all passengers using the airport and by implication mainly UK outbound passengers.

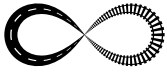

## RAILWAY AS THE SOLUTION FOR ROAD CONGESTIONS

Darja Šemrov<sup>1</sup>, Aleš Pavšek<sup>2</sup>, Franc Zemljič<sup>3</sup>

*1 University of Ljubljana, Faculty of Civil and Geodetic Engineering,  
Traffic Technical Institute, Slovenia*

*2 DRI Investment Management Ltd, Slovenia*

*3 Slovenian Railways, Slovenia*

### Abstract

The goal of this paper is to present rail as a sustainable means of transport and to point out the factors influencing passengers to change the modal split from car to train. The changes in modal split can be achieved by offering attractive timetables, obstacle-free access to railway stations and trains, high train frequency, well-performing information systems, comfortable and secure rolling stock and stations, and public awareness of rail and road passenger transport environmental impacts. Rail transport is a good solution for the reduction of road congestion at peak hours, reduction of external costs, increase of mobility (seniors, students, people with reduced mobility, etc.). In this paper, the economic, financial and social benefits are listed as well as the impact on the environment.

*Keywords: passenger rail transport, congestion, external costs*

### 1 Introduction

Our society and especially today's business life is structured by tight time-schedules. Time is a valuable good; therefore, passengers make destination-, route- or mode-choice decisions by taking into account both the travelling time and its value. Passengers calculate benefits for each alternative and choose the one which shows the highest usefulness. But what is the usefulness of a car stuck in a traffic jam? When choosing transport mode not only normal trip duration, but also the reliability of the arrival time is taken into account. Because time is a valuable good, the reliability of the transportation system is a decisive factor. If there is congestion on the road without additional lane for buses, even buses cannot keep their timetables because they are in congestion, too. In contrast, rail is independent of road traffic and congestion, so the train can keep its timetable and arrives on time. Public transport users consider a fair number of attributes of a trip, not only travelling time, when making their modal decisions: station access time, in-vehicle-time, reliability, number of transfers, time required for the transfers, headway, comfort (type of train set), quality of the station, in-train services, general cleanliness of the system, etc.

The challenge of the EU is to reduce the emissions and the energy consumption due to transport activities, in order to avoid or to reduce the related environmental impacts (mainly the air and noise pollution in urban areas, with the consequent effects on human health and on local and regional environment, and the production of greenhouse gases), without affecting the economic growth.

In the period 1994–2010 Slovenia was building the motorways network; therefore the investments in local roads and railway maintenance were poor. After the highway network had been built, a priority should have been the increasing of rural mobility. There are approximately 120,000 daily commuters in the Ljubljana urban area (OD home to work, and OD home to edu-

cation). The road congestion in peak hours occur daily on the main roads towards Ljubljana. The drivers on most routes have only one alternative, the bus, which cannot compete with personal transport due to long travel times (often there are no bus lines) and high fares. Additional roads could be built or the existing rail infrastructure could be used for the passenger transport. Modest but vital improvements in rail capacity can provide a viable alternative for commuters who face increasing congestion on the existing road network.

## 2 Parameters to increase the attractiveness of rail travel

Rail transport experienced a rapid decline in the second half of the 20th century, mainly due to the developments of roads and a change life style. There are several reasons for this. The EU goal is to achieve sustainable transport system and it is evident that a change is necessary so that travellers will again prefer to use a train instead of a car.. The success of railway public transport depends on three elements: the level and quality of the rail service, the level and quality of the access to the rail service and the characteristics of the area and population served. In a short term, rail operators have little influence on the characteristics of the population served, but they can control the level of service provided and the access to it. Therefore, efforts should be made to improve the level of rail service offered; mainly in terms of improved network coverage, shorter travel times, higher train frequency and higher service reliability. Such efforts focus on the actual train trip. Another option to increase rail use is to make rail services more accessible by wider geographical coverage of access services, shorter travel times to the railway station and better quality of service of travel to and from the station and at the interchange points between the modes of transport used to get to/from the station and the rail.

Efforts to increase rail use usually focus on the rail service itself while the accessibility of the rail network receives less attention, but the results of studies [4] shows that the satisfaction with the level and quality of the access to the station is an important parameter of the rail trip which influences the overall satisfaction. Good quality of access facilities to passengers will likely result in increased rail use. The quality of access facilities was found to be even more important for infrequent rail passengers, indicating that improving the access to the rail network has the potential to increase their use of rail and can attract new passengers.

Public passenger transport service requirements, target, and measure quality of service and guidance for the selection of related measurement methods are specified in European Standard SIST EN 13816:2003 [3]. Its use promotes the translation of customer expectations and perceptions of quality into viable, measurable, and manageable quality parameters and therefore this standard should be used by service providers in the presentation and monitoring of their services.

Standard SIST EN 13816:2003 sets out the comprehensive list of quality criteria and deals with aspects of performance measurement. Quality criteria are structured in three levels, where each successive level is more detailed. Level 1 contains eight criteria:

- 1 availability (criteria related to the geographical coverage of public transport services, public transport frequency, transport mode and distance to public transport),
- 2 accessibility (criteria related to the connection of public transport and other transport modes and physical access to public transport services – obstacle free access for public transport users, safe and appropriate parking area for cars and bicycles at public transport stations, etc.),
- 3 information (criteria related to data provided for trip planning and data provided during trip – information available to the user regarding the availability, accessibility, travel time, directing signs, etc.),
- 4 time (criteria related to time spent on planning and realization of travel – duration of trip, public transport punctuality and reliability, etc.),
- 5 care for customer (criterion related to the elements that makes easier and more enjoyable passenger trip – user orientated service, staff availability and attitude, providing help and

- information in case of unexpected event, providing help to disabled/young/senior passengers, etc.),
- 6 comfort (criteria related to the functionality of the equipment at railway stations and on rolling stock and the appearance of the station surroundings – stations and vehicles equipped with seats and space for passengers, comfort during trip, cleanliness, lighting and additional accessories and services like toilets, baggage space, accessibility to communications (Wi-Fi) at the station and on board, etc.),
  - 7 security (criteria related to the actual level of safety from crime or accident and the consequent sense of safety – lighting, video surveillance, presence of staff/police, emergency rescue, etc.),
  - 8 environmental impact (criteria related to the different effects that the public transport has on the environment – green house and noise emission, vibrations, energy consumption, etc.).

### 3 Benefits of modal split from road to rail

When comparing road and rail transport system, several benefits of rail passenger transport can be identified:

- economic benefits (employment, time and external cost effects, local development impact),
- financial benefits (costs of the trip by train and car)
- social benefits from the increased mobility (increase of access to education and medical care, personal independence),
- impact on the environment.

#### 3.1 Economic benefit

There are several economic impacts of modal split change, namely the impact on the employment, time consumption, external costs and local development.

As employment is a primary means of income and self-sufficiency in society, access to employment is vital to achieving a number of social goals. Therefore, a lack of transportation can be a serious barrier to employment. The use of public transport to increase incomes and reduce dependency on welfare applies especially to persons without a car or persons unable to drive because of disabilities or other reasons. If these 'transportation disadvantaged' persons can be moved from a position of dependence on welfare funding to one of supporting themselves (and paying taxes), the benefits of this change are obviously substantial for the individual and society as a whole. Those transit systems that focused on trips to work generally had very large economic impacts.

There is a great amount of time losses caused by congestion. According to Handbook [2] the value of time is €24 for business passenger hour, €8 for commuting passenger hour and €3 for freight ton hour (average of €30 for HGV hour). Taking into account 1000 vehicles per hour losing 30 minutes in congestion in the morning and afternoon peak hour, such congestion causes the loss of 1,000 hours a day. Multiplied by values from the Handbook only time cost per hour amount to approx. € 12,000 per workday peak hour and to approx. € 3.1 million per year. If peak hours last longer than one hour the time cost is substantially higher.

There have been several studies on external costs on EU-level prepared (CAPRI, 1999; UNITE, 2003; INFRAS/IWW, 2004; CAFÉ, 2005; HEATCO, 2006; GRACE, 2007). In order to uniform conclusions and unit external costs of transport the Handbook was prepared. This Handbook provides unit costs for several external cost drivers in order to internalize external costs and include them in the cost-benefit analysis. In accordance with the Handbook the average unit values of external cost in are approx. 8 times higher on road (petrol cars) than on rail (electric trains) in urban areas and approx. 5 times higher in suburban/interurban areas (4.11€ct/pkm vs. 0.56€ct/pkm in urban area and 2.06€ct/pkm vs. 0.46€ct/pkm in interurban area). In the unit value of external costs noise, accidents, air pollution and climate change costs are included. Congestion costs are excluded. In case of 500 passengers they would cause €20 external

cost per kilometer on road and only €2.5 external cost per kilometre on rail. If there is 40 km trip, the total difference between road and rail users is €700 per trip. In other words, there would be benefit of passengers using rail instead of road in amount of €1,400, taking morning and afternoon peak hour into account. In one year (250 working days) the total difference between road and rail external costs amount to €350,000.

Transport infrastructure also impacts local development. The more developed infrastructure influences accessibility of an area, which becomes more interesting for investors. Good connections usually lead to growth of industrial and residential investments, and consequently to the development of the area. Similarly, congestion play an important role in the attractiveness of certain area.. Regular daily congestion, especially at peak hours, discourages both, potential investors and residents. Therefore, reducing congestion is an important indicator in the investor/resident decision process. With rural public transport system, areas that depend on tourism can experience greater levels of economic activity than they would otherwise. They can offer more attractive, less crowded environment to visitors. These tourist areas can also offer higher levels of personal service in restaurants, hotels or other business establishments. Consequently, such businesses increase employment opportunities for locals.

### 3.2 Financial benefit

Also financial aspect for passengers needs to be considered. The only cost for the passenger using railway is the price of a monthly ticket. The road user has to consider at least the following costs: fuel consumption, parking fee, vehicle amortization, registration fee and insurance. The following table is an example of the ratio between financial costs of rail and road trip, taking into account the prices in Slovenia for 2012.

**Table 1** Financial benefit of rail transport.

length [km]	costs [€]		ratio [%]
	road	rail	
20	8,16	3,90	48
55	14,04	7,68	55
70	14,54	8,77	60

### 3.3 Social benefits

Access to education enables travellers to increase their long-term chances of employment at a decent wage. Even when considering that not all persons will graduate and obtain full-time employment, the benefits of such trips are large.

Access to medical care and other social services enables the travellers to use services that increase their health and quality of life. Health centres are located in urban areas; therefore, rural rail connection is particularly vital for those persons without cars or those persons unable to drive because of disabilities, poverty, or other reasons. Trips to health centres are beneficial to those who are unable to drive home safely due to the consequences of their treatment.

For seniors, living in their own homes is often much more cost-effective than other alternatives, nursing home care being one of the most costly. Rural transit systems assist in enabling the continuation of independent living by providing persons without a car or those persons unable to drive because of disabilities the possibility of continuing live in their own homes rather than having to live in nursing homes. Benefits like these are especially relevant in the areas with large elderly populations. Such areas can obtain substantial benefits from

providing accessibility to medical treatment, shopping, social services, and personal needs, without which seniors would not be able to stay in their own homes.

### 3.4 Impacts on the environment

In EU, almost one third of all energy is used for transport, moreover; the use of energy for transport is increasing while other uses are relatively stable. In accordance with Energy balance sheets 2007–2008 [5] there was an increase in energy consumption in transport sector in Slovenia by 17% between 2007 and 2008. The energy consumption remained the same in rail sector but increased by 17% in road sector. In the same period in EU27 energy consumption in transport sector remained almost the same; in the road sector decreased by 1% while increased by 1% in rail sector. Higher energy consumption in road sector leads to higher environment pollution. As explained in the Chapter 3.1 the external cost (monetized environmental impacts) are higher in the road sector than in the rail sector.

## 4 Conclusions

Although the above mentioned public transport system benefits (economic, financial, social, and environmental) appear to be obvious, they are far from universal. Most rural transportation systems were not established with specific economic objectives. In fact, many of their objectives are social in nature, such as access to work, education and health care services. This does not preclude economic benefits; it simply means that the economic benefits, where they occur, may be hard to find and to separate from social benefits.

To conclude, the effect of railway versus road, its requirements and its impact on several areas have been discussed. The success of rail public transport depends on three elements: the level and quality of the rail service, the level and quality of the access to the rail service, and the characteristics of the area and population served. The benefits of modal split from road to rail were introduced. Comparing the costs of rail trips and road trip, the former is almost half of price of the latter. Finally the effects of time and external costs were presented.

Transport demand is closely related to economic development. Transport is a very valuable and necessary part of modern society but widespread and increased traffic is recognized as a major contributor to an extensive range of undesirable side-effects. Traffic congestion makes cities less friendly and reduces the efficiency of the road transport system by increasing travelling time, fuel consumption and drivers' stress. Therefore, the transport mode is chosen not only according to normal trip duration, but also by the availability, accessibility, comfort and safety aspects. From this point of view, passenger rail transport is a good alternative to passenger road transport. Railway operators should promote activities to increase the attractiveness of rail transport mentioned above.

## References

- [1] A Handbook for Measuring Customer Satisfaction and Service Quality, National Research Council, Transportation Research Board, Washington, D.C. 1999
- [2] Maibach, M. et al.: Handbook on estimation of external costs in the transport sector, Internalisation Measures and Policies for All external Cost of Transport (IMPACT), Version 1.1, Delft, CE, 2008
- [3] SIST EN 13816:2003 (Transportation - Logistics and services - Public passenger transport - Service quality definition, targeting and measurement), European Committee for Standardization, 2003
- [4] Brons, M., Givoni M., Rietveld, P.: Access to railway stations and its potential increasing rail use, Transportation Research Part A 43, 2009, 136–149
- [5] Energy balance sheets 2007 – 2008, EUROSTAT, 2010 edition



## 10 RAIL TRACK STRUCTURE





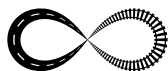

## LIGHT RAIL TRACK STRUCTURE COMPARATIVE ANALYSIS

Mirjana Tomičić–Torlaković<sup>1</sup>, Vladan Branković<sup>2</sup>

*1 Civil Engineering Faculty University of Belgrade, Serbia*

*2 Ministry of Infrastructure and Energy, Serbia*

### Abstract

In the paper the review of the light rail track structure for that kind of public passenger transport from the accessible literature and authors's engineering experience is carried out. For that purpose the light rail track structure are classified into structures on discrete supports, either on sleepers in ballast bed or on slab, and structures continuously supported. For all of them the examples are presented. In that way, the systematization of main existing track structure types of light rail system is performed.

On the basis of those data, the comparative analysis of the light rail track structures, in respect to the technical, economic, operating and ecology requirements with the respect to the several criteria, is carried out. From that analysis the resent conclusions are derived.

*Keywords: light rail system, public transport, track structure, slab track, comparative analysis.*

### 1 Introduction

Light rail system ('Light rail' or 'Light Rail Transit' – LRT) is a particular class of urban public passenger railway that utilizes less massive equipment and infrastructure with modern light vehicles of great capacity. The term was adopted as a conscious break from the obsolescent image of trams and sometimes used largely for political reasons in order to obtain the financial support. It is usually the upgraded tram system or reused old railway netlines [1].

Light rail traffic is an integral part of the public transportation systems in many central city areas. The proximity to the neighboring buildings, the environmental protection from vibration and noise and the necessity to share the route with motor traffic are the main factors for track design and construction.

Depending on the route, light rail line may be built atgrade, on elevated structure or in tunnel. Light rail has an average speed of 25 to 35 km/h in urban areas or even higher at exclusive tracks. Track geometry must has the ability to handle sharp curves and steep gradients, making it possible for the light rail vehicle to be integrated in the existing city infrastructure. The minimum horizontal radius is depending of the construction of the chosen vehicle, which is commonly long and articulated one. For vertical curvature also the vehicle construction is decisive for the minimum curve. The demanding comfort for the passengers throught maximum acceleration, depending of the speed of the vehicle, should be taken into account designing the track. The capacity of light rail is higher as is the maximum speed, for which the more free track, or better more exclusive track, with optimum structure is needed [2], [3].

## 2 Classification of the light rail track structure with the examples

The track superstructure consists of the track grid itself (rails, rail fastenings and sleepers) and the track bed made up of ballast or bonded bearing layers (concrete, bituminous materials or something similar). Underneath these layers are under ballast mats, protective layer, anti-frost layer, which some regulations classify as part of the substructure. The light rail track, besides the primary well known requirements, must fulfil the following [4]:

- Operational safety that demands exact track arrangement during construction and maintenance;
- Ease of access for road vehicle, where applicable;
- Electrical conductivity and insulating properties;
- Avoidance of stray current and corrosion of metallic elements;
- Noise abatement and vibrations attenuating;
- Resistance to the chemical action presented in urban areas.

The types of track structure used on light rail systems vary, depending on urban and routing requirements and the local environment. The track can be open track, covered track and mixed systems (partially covered).

The types of the light rail track structure according to the way of rail supporting are those with: discrete supports, and continuously supported.

Track with discrete rail supporting according the kind of rail base can be on the:

- sleepers in the ballast (ballasted track structures), and
- solid (concrete or asphalt) bed (ballastless, slab track structures), with or without the sleepers.

### 2.1 Light rail track structure with discrete rail supports

#### 2.1.1 Light rail track structure with sleepers in the ballast

Although the traditional ballasted type of railway track structures can be used where the light rail is separated from the road traffic, the main drawback of that classical railway structure is the high cost related to its inspection and maintenance.

The traditional ballasted track is with the lower edge of the sleepers usually rests on a base of 25 to 30 cm of compacted ballast. The improvement can be made by incorporation of elastic elements by building in the under ballast mats and the sleeper pads, in combination with other measures, such as frame sleepers or concrete trough. Under ballast mats reduce the dynamic forces by adding the damping to the system and isolate it from structure-born noise (figure 1. left) [5]. Elastic sleeper pads are suited for vibration mitigation, avoid gauge widening and lower the track stiffness (figure 1. right).



Figure 1 Additional building in the under ballast mats and the sleeper pads

### 2.1.2 Light rail track structure on solid base

Especially, where the light rail share the same space with the road traffic the track design tends towards the track without ballast. The main advantage of the ballastless track is low maintenance effort and high availability.

Characteristic feature of ballastless or so-called slab track structure is the supporting of the rails on treated layers (concrete or asphalt) by specified resilient supports to reach a sufficient and uniform load distribution and the permanent fixation of track geometry. In that way, the required elasticity of the track is guaranteed solely by the support point elasticity and, at the same time, the base course structure (a frost protection layer, a hydraulically bonded layer and a final concrete or asphalt layer) is characterised by a rigidity increases from the bottom up. So, the minimum deformation modulus for these layers are: on the track formation  $E_{V_2} \geq 45(60) \text{ MN/m}^2$ , and on the frost protection layer  $E_{V_2} \geq 100(120) \text{ MN/m}^2$ . Such slab track solutions require very high laying precision in the position and height with level accuracy of  $\pm 2 \text{ mm}$  and the permanent constancy of the structure even. The width of the concrete or asphalt base layer amounts to 3,20 m (180–300 mm thick), while the width of the hydraulically bonded layer amounts to 3,80 m (300 mm thick) [6].

The rail fastening systems are either direct without ribbed plates (f. e. system 300 Vossloh) or indirect with ribbed plates (f. e. system 336 Vossloh). Height correction amounting to 20 mm and lateral correction of only 4 mm are possible [7].

A few typical systems for light rail track construction of slab system will be explained below.

Rheda City consists of bi-block sleepers connected by lattice girders embedded in cast-in-place concrete after fine alignment and height adjustment of the track panel by using spindles (Figures 2.). Special rail seats (type Ortec) can be employed for added vibration protection (variant Berlin NBS). The track covering can be provided in several asphalt layers, concrete, paving blocks, or with humus substrate in the case of so-called green track (variant Rheda City Berlin or NBS-G) [6].

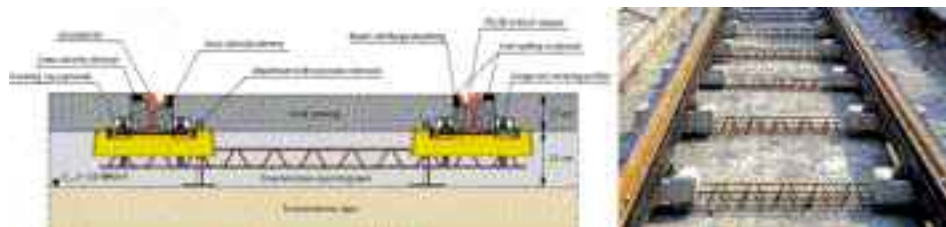

Figure 2 Rheda City

ATD design consists of several asphalt layers with longitudinal plinth in the middle against transverse forces. The bi-block sleepers are laid directly onto the asphalt layers (Figure 3.). Because of asphalt's visco-elastic properties these track have the slight plastic adaptability. The material is moreover reusable and the system allows exchange of sleepers in case of damage by derailments [6].

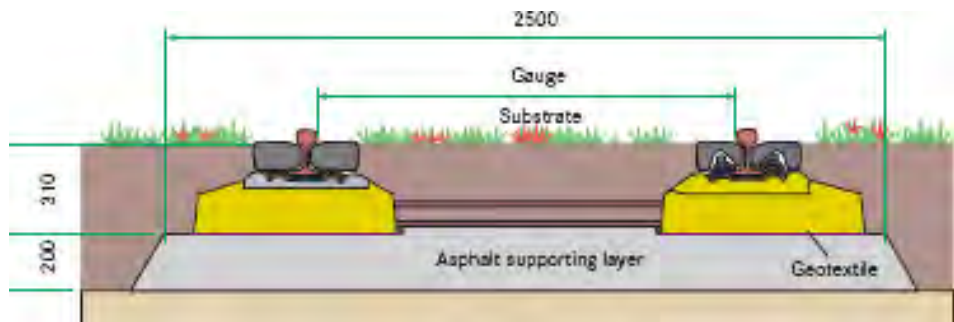

Figure 3 ATD system

BÖGL system consists of prefabricated slabs with pre-assembled rails on the hydraulically bonded base, which are spindled to the required height (Figure 4.). The slabs are coupled with turnbuckles and the joints between them and the base layer are filled with bitumen-cement mortar through openings in the slab [6].

INPLACE track design is characterized by track panel with precast rail chairs set in cast-in-place longitudinal concrete beams or slabs by 'top-down method' (Figure 5.) [6]. Mass-spring systems (or so-called 'floating slabs') are completely separated from the substructure and the sides by using elastic intermediate elements. They are used in applications where the isolation and comfort demands are very high. Decisive parameter for noise and vibration absorption is the natural frequency (eigen-frequency) of the whole selected system (between 15 and 23 Hz for light system and between 7 and 12 Hz for heavy system). Over recent decades, a wide range of mass-spring systems have been developed. There are systems that use continuously reinforced in-situ concrete or prefabricated prestressed concrete components, their combination, with or without a ballast bed. There are three different types of such systems: full surface layer, linear support and discrete bearings (Figure 6.) [8],[9].



Figure 4 INPLACE system



Figure 5 'Mass-spring' systems

## 2.2 Light rail track structure with continuous rail supports

The advantages of the elastic continuous supported rails are the absence of dynamic forces due to secondary bending between discrete rail supports, reduction of noise emission, increase in the life span of the rails and further reduction of the maintenance. Track structures with continuously supported rails are always slab tracks.

INFUNDO/EDILON system (Figure 7.) is made of continuous concrete slab by using slipform paver, prefabricated or semi-prefabricated. It contains the grooves for rails laid on elastic strips and embedded in compound. Semi-prefabricated solution provides a high accuracy of execution and concrete quality in the areas of the rail fixation system [10], [11].

CDM-Cocon track system consists of H-shaped concrete frames in lengths of 18 m (Figure 8.). On the top of longitudinal sleeper the bistrip for rail is applied. The rail web chambers are glued to the rail to avoid the contact with surrounding concrete or asphalt [10].



Figure 6 INFUNDO/EDILON system

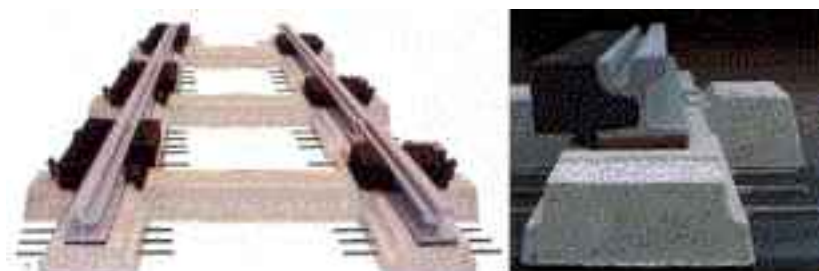

Figure 7 CDM-Cocon track system

## 3 Comparative analysis of the light rail track structures

The evaluation of the various technical solutions available for the light rail track structure is a difficult task, because of far too of them, which have to be justified by different local condition. The comparative analysis for the several criterion and essentially only two track types: ballasted track and ballastless slab track is going to be carried out. For these two alternatives the qualitative list of the criteria under the four target requirements is presented (Table 1.). In the table 1 the solution with outstanding priority is signed as  $\bullet$  and the solution with possible competitiveness but under the additional technical measurements is signed as  $\oplus$  [4], [12], [13]. Unevaluated criteria for some option usually means that the certain option is not concurrent even with the additional technical measurements.

According to the present knowledge, the slab track has a building and installation cost level of from around 1,2 (sleeperless design) [14] to even about 2,6 times ballasted track (500 euros pro 1m of track length) with great disipation [15]. From the technical standpoint the similar and less sensitive the track design, the easier is to manufacture and the more reliably high quality can be achieved. To improve manufacturing tolerances and to shorten construction time (building work in urban environment causes traffic disruptions) the semi–precast unit solutions for slab track design are opted especially when building new sections of track.

**Table 1** List of requirements and criteria for two options

Requirements	'Criteria	Options	
		Ballast track	Slab track
Minimum investment costs	– Superstructure construction costs	●	
	– Superstructure construction time	●	⊗
	– Superstructure weight (bridges)		●
	– Superstructure height (tunnels)		●
	– Site access conditions for mechanisation	⊗	●1)
	– Building materials delivery conditions	⊗	●2)
	– Susceptibility to substructure quality	●	⊗
Minimum operational and maintenance costs	– Engagement of domestic contractors	●	⊗
	– Durability of track geometry		●
	– Need for subsequent track geometry regulation	⊗	●
	– Maintenance and repair costs		●
	– Possibility of rail reuse and recycling	●	⊗3)
	– Track life–cycle time		●
	– Possibility of track cleaning		●
Minimum environmental impacts	– Integration in the streets	⊗	●4)
	– Integration into traffic infrastructure		●
	– Emission of noise and vibration	●	⊗5)
	– Visuel route integration in urban environment		●
	– Space occupancy of inner sity areas		●
Maximum safety	– Preservation of space entities		●
	– Water contamination and soil degradation		●
	– Track stability at high temperatures		●
	– Accesibility for staff and rescue–vehicles	⊗	●

Notes:

- 1) – Advantage of the track with continuously supported rails
- 2) – Advantage of the track with continuously supported rails
- ⊗3) – Advantage of the track with discrete rails supports
- 4) – Advantage of the track with continuously supported rails
- ⊗5) – Advantage of the track with continuously supported rails

Fully precast units deamed advantageous under specific circumstances. The diversity of design variants can be greatly reduced by standardising the precast units. Choices in favour of special designs should be dictated by local requirements, such as the need for greater protection against vibration or strey currents, or crossing by traffic. The space restrictions in innersity track network often prevent construction work from being mechanised and prolonged the construction time.

In longer tunnels (over 500m) slab track has been accepted as the standard superstructure, because the maintenance work on ballasted track would be difficult and unsafe, the less height (by about 30 cm) means the smaller tunnel cross-section and reduction for the excavation, but in case of accidents it must be accessible for rescue vehicle. As the result, the installation costs for the track and tunnel combined are not higher for solid base track than for ballast track [16]. The main requirement in using slab track design is a settlement free foundation. Problem locations discovered during investigation of the ground must be remedied by suitable geotechnical ground improvement measures to meet the requirements.

The higher production investments costs for slab track are compensated by cost savings in maintenance and additional revenue from the higher availability of the route. The slab track systems require hardly any maintenance. The lasting good track quality up to now, does not only guarantee a minimum of maintenance and improved driving comfort for the citizens, but as well as the highly available track. The durable stable position of the slab track and the track quality has been proven [15]. The maintenance work is restricted to replace the rails when the rail heads have suffered a certain amount of wear and tear, changing of the synthetic rail pad and preventive rail grinding (slower corrugation develop, stop the beginning of headchecks and decrease noise production).

In maintenance costs domain slab track is clearly more advantageous than ballasted track (no sleepers tamping, rail realignment, ballast cleaning and packing, vegetation control with herbicides and so on). The costs of operational impediments by maintenance work that include substitute services, reduced speeds, single track operation, depends of the duration of the required work and all design requiring shorter installation times are clearly advantageous (pre-cast or semi-precast units).

For slab track no precise repair costs is available yet since no major repairs have been required so far, but it may well prove that would cost more than repairs to ballast superstructure. Full renovation of slab track may only be needed in exceptional cases and then be restricted to individual sections of track. In general, the more solid the design, the higher the waste costs in the event of renovation compared with a ballasted track alone.

Track life-cycle time for the slab track is much longer (proposed about 60 years). If profitability factors are taken into account when comparing the technical aspects of the track solution, the costs over the entire lifetime (life-cycle costs, LCCs) of the given system need to be examined in each case. Beyond that, factors that cannot be costed can play as decisive role as those which can be evaluated in monetary terms. On the other hand, exist no sufficient long-term experiences with solid base track in the inner-city areas (about twenty years). From a LCC standpoint, the ballast superstructure is economically superior to slab track. The maintenance and availability benefits of slab track are usually not sufficient to make it economically preferable to the ballast superstructure [14]. There is the opposite opinion that ballastless track is more economic than ballast track because its long-term annual costs are lower [15].

Consequently, as a rule, switching from ballast to slab track on an existing light rail line is not an economically attractive proposition. For slab track to be economically superior, it must be a new line, whereby the other advantages of slab track apply at the same time [14].

Noise and vibration insulation of slab track is achieved by the installation of sound-absorbing components and acoustic barriers, which raise the costs and can make maintenance more difficult. In the densely-developed areas, around light rail lines sensitive to vibration quality protection, raises investments costs, especially when mass-spring systems are required [5]. Better integration into the urban environment shows all types of slab track, especially so-called 'green track' designs, which greatly contribute to the acceptance of new line and therefore enhance their feasibility.

A conventional ballast superstructure remains the preferred solution for all tracks on independent formation. On the other hand, when tracks runs along the streets or are finished as green track, the difficult accessibility and the maintenance and repair problems of ballasted track lead to a preference for slab track.



## 4 Conclusions

In each individual case, when comparing the investment and life cycle costs and profitability of different types of light rail track structure over their full lifetime as part of the overall consideration of the design solution, a wide amount of factors and requirements needs to be taken into account. The created qualitative list indicates that evaluation of the many involved contributed factors is the only way to arrive the technically and economically balanced result when selecting the track structure design for a given section of light rail line. The final choice depends on the track's location.

The cheapest solution may not always be the best and most cost-effective when all factors are taken into account. Success of choice depends on the combined, greatest possible fulfilment of all these factors and criteria, which is why there can be no unic solution for track structure used for public light rail passenger transport in city.

## References

- [1] Vuchic, V.: Urban transit systems and technology, John Wiley & sons, USA, 2007.
- [2] National Research Council: Track Design Handbook for LRT, Report 57, National Academy Press, Washington, D.C., 2000.
- [3] RTD Denver, Colorado: LRT Design Criteria Manual, 2005.
- [4] Brankovic V.: Light rail track superstructures (in serbian), master tesis, Civil Engineering faculty University of Belgrade, 2011.
- [5] Tomicic - Torlakovic M.: Railway track structure with a reduction noise emission (in serbian), Proceedings JUZEL 2000, Vrnici spa, pp. 510-513, 2000.
- [6] Darr, E., Fiebig, W.: Feste Fahrbahn, Konstruktion und Bauarten für Eisenbahn und Strassenbahn, Eurail press, 2006.
- [7] Mörscher J.: Schotterloser Oberbau in Netz der Deutsch Bahn AG, ERRI Conf. 'Cost effectiveness and safety aspects of railway', 1998.
- [8] Getzner: Informaktuell, 2/1999.; 2/2000.; 3/2000.; 2/2001.
- [9] Tomicic - Torlakovic M., Puzavac L.: Permanent way structure with mass-spring system (in serbian), Zeleznice, Vol.58, No.11,12, pp.349-360, 2002.
- [10] Esveld, C.: Modern Railway Track, TU Delft, 2001.
- [11] Tomicic - Torlakovic M.: Track construction with embedded rail (in serbian), Proceedings of seminar 'Railway infrastructure', Zlatibor, pp.13-18, 2000.
- [12] Becker, S., Lier, K.H.: Bewertung und Varianten-vergleich von Bauarten der Festen Fahrbahn, Eisenbahningenieur, 2/1999.
- [13] Popovic Z.: Slab track design and system comparison (in serbian), iNDiS 2009, Novi Sad, 2009
- [14] VDV, Düsseldorf, 2007.
- [15] UIC: Feasibility study 'Ballastless track'- report, 2002.
- [16] Girnau, G., Müller-Hellmann, A., Blennemann, F. (editing): Light Rail in Germany, vdv, Düsseldorf, 2000.

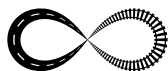

## TECHNICAL PARAMETERS FOR SELECTION OF ELASTIC RAIL FASTENINGS

Tatjana Simić  
COWI doo, Serbia

### Abstract

According to the Agreement for the establishing of a high performance railway network in South East Europe (Official Gazette of RS nr.102/2007), an initiative has been set up in Republic of Serbia to fulfil all measures defined in the Agreement. Driving speed increment in the existing railway track conditions requires an improvement of superstructure elements, especially of the rail fastening, the role of which is to transfer load from rails to the sleepers with retaining pulling force as long as possible. Significant attention, in the process of track construction and future maintenance, should be given to the thorough analysis of modern fastening types and their unification on the „Serbian Railways“ network. It is even more important as nowadays plenty of different types exist.

Position of the UIC is that selection of rail fastenings should be left to the national railway administrations. Selection of the manufacturer/type of rail fastening and its installation and inspection during the exploitation should be the result of a compatibility between technical (permanent) track elements and fastening features, which is the subject of this report. Technical parameters, concerning the track are: axis load, driving speed, track geometry (situation and levelling), superstructure features (rail and sleeper types), modes of installation and level of mechanized maintenance. Elastic rail fastening characteristics which are relevant for manufacturer/type selection are: constructive elements of considered system (mass, tensile strength, material in use and its properties), purchasing price, installation simplicity, changes of its characteristics during exploitation and maintenance costs.

This report will consider elastic rail fastening systems for concrete sleepers manufactured by Pandrol (UK) and Vossloh (Germany), which have been leaders in technical improvement and development of high speed railway tracks on the European railway network for a long time now. Some of these fastening systems were also applied on the „Serbian Railways“ network. Experiences gained through the installation and exploitation are also included in this report.

*Keywords: elastic /resilient rail fastening, installation, exploitation, maintenance*

### 1 Introduction

Pursuant to the European integration processes, planned renewal and development of the railway infrastructure will have great significance in the future. Planned measures should enhance traffic infrastructure across Serbia and South East Europe and lead to faster and higher quality connections between industry and trade centres.

Since none of the existing main railway lines in Serbia comply with contemporary traffic demands concerning capacity, service quality and journey time, the final objective is to make railways more attractive for both passenger and freight traffic by reconstruction/extension of existing railway lines and driving speed increment.

## 2 Track parameters influencing the selection of resilient rail fastening in the superstructure

Data that has affect on the selection of superstructure elements should be defined in the Terms of Reference, such as: railway line category, axis/traffic load and line speed-limit. Additionally, track design as well as radius in curves and gradient, should also be considered.

Based on these data a selection of elastic rail fastening can be made, despite the fact that domestic regulations don't give unique criteria.

Selection of a rail type is in close connection with the traffic load/axle load (speed dependant) and speed-limit. Some researches have showed that with heavier rail type a more stable, low maintenance railway track is achieved. This way the maintenance cycle is prolonged and exploitation costs are decreased.

On new railway lines and on reconstructed main railway lines new standardized 49E1 and 60E1 rails are built, with quality mark 260 (according to the new EN standards), which corresponds to former rails with 880 N/mm<sup>2</sup> tensile strength. In the current rail production this is the lowest quality. 49E1 type rails are built in case of axle load up to 225 kN, total annual traffic load up to 10 millions bruto tons(BT) and speed-limits up to 120 km/h. When any of these criteria is exceeded, 60E1 type rails are built.

These criteria are based on the regulations of 'Serbian Railways'network, many European railway authorities (primarily DB of Germany) and UIC-ORE data.

Criteria are set according to the technical and economical parameters (safety vs. investment and maintenance costs). Selection of heavier 60E1 type rails increases safety and reduces superstructure maintenance costs, but because of construction weight can also increase substructure maintenance cost if it's not built as designed (which is very often the case of the overhaul of the main lines). During the investment planning we should have in mind that the weight difference between the 49E1 and 60E1 type rails is about 21,80 kg/(m' of track), which increases purchasing price of the 60E1 type rails, i.e. price of works for laying and regulation of the rail track.

Selection of the fastening system is conditioned with functional and constructive characteristics, i.e. with the degree of fulfilment of exploitation requirements for contemporary superstructure constructions.

### 2.1 Parameters for fastening system selection

a

- unctional:
- Permanent holding of the designed track geometry with blocking of longitudinal movement and bending of the rail (Figure 1),
- Providing of continuous friction between rail and sleeper (Figure 2),
- Providing of spatial elasticity for rail support on sleepers (Figure 3).

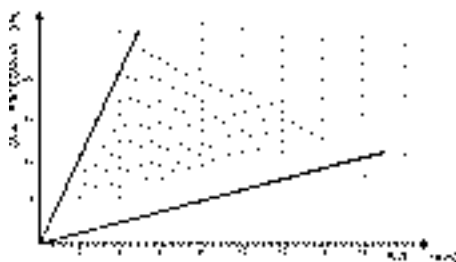

Figure 1 Area of operation 'fastening force vs. longitudinal movement' for elastic connection rail - sleeper

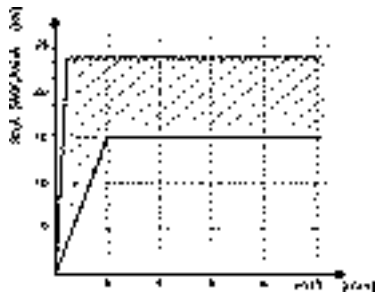

Figure 2 Area of functioning for longitudinal movement for elastic connection rail - sleeper

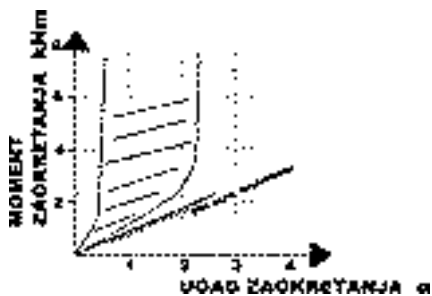

Figure 3 Area of functioning for rail bending resistance for elastic connection rail - sleeper

b

- constructive:
- minimal number of parts, minimal mass
- electrical insulation of track,
- simple and fast installation,
- easy component replacement,
- controlled degree of distortion,
- simplicity of operation during the loosening and reformation of continuous welded rail (CWR),
- possibility of installation in turnouts, diamonds and expansion joints (basic type or modification) and prevention of easy deinstallation from unauthorized persons (vandalism).

c

- production effectiveness, maintenance and environmental protection:
- cost-effective production,
- possible production in Serbia (parts or whole system),
- minimal installation and maintenance costs,
- environmental friendly materials.

In addition to previous parameters, during the fastening selection process, it is also necessary to meet the requirements from standards EN 13146-1/8 and EN 13481-1/7.

### 3 Resilient rail fastening

#### 3.1 General features

As it's been previously stated, factors depending on rail fastening selection are traffic load, axle load, speed-limit, possibility of mechanized maintenance, simple installation and maintenance, frequency in necessity for maintenance, etc. Combined with the rubber pad, elastic fastening gets a double elastic connection. Rubber pad accepts downward impacts and amortizes high-frequency oscillations (1000-3000Hz), reducing the energy that transmit to the sleepers and ballast, and steel elastic element – tension clamp keeps rail foot from the top side and resists to the uplifting, due to the permanent attachment to the rail. In this way a connection between the rail and pad is permanent, there are no rail impacts on the sleeper and loosening of the connection. Such fastening is resilient in both directions - upwards and downwards.

Fastening force in such cases is almost constant. There should be no need for additional tightening during the exploitation. Longitudinal movement resistance is constant (high friction between the rail and rubber pad), which disables rail movements and there is no need for anti-movement tools. Fastening itself is less in weight, with less maintenance and installation and deinstallation is faster and simpler. Superstructure (rails, sleepers and fastening) under certain conditions enables transmission of:

- return traction current between the vehicles and substations,
- current for signalling and CTC purposes

As for the return traction current, specifications for rail steel quality are usually enough to provide this function. But, track should also be compatible with regulations concerning the electrification system. In order to provide an adequate transmission of the current for signalling and CTC purposes, a certain level of insulation between rails must be guaranteed, which is a characteristic function of the resilient fastening and sleepers. Since this request can differ depending on signalling and CTC systems and their functional demands, resilient fastening should be confirmed as an interoperative element.

Comparative technical-economical analysis of fastening systems show that for open line tracks and station main tracks/loops the required criteria are fulfilled by resilient fastening systems VOSSLOH, Pandrol and NABLA. Final selection of the elastic fastening system should be done through elaborate based on the multicriterial optimization principle, consisting of precise quantification of technical, economical and environmental criteria.

#### 3.2 Resilient rail fastening systems – wooden sleepers – ballasted track

In cases of usage of resilient rail fastening for wooden sleepers, following suppliers and products exist: Pandrol "K" CONVERSION SYSTEM (Figure 4 left) and Vossloh FASTENING with 'SKL12' tension clamp (Figure 4 right)



Figure 4 Resilient rail fastening for wooden sleepers

### 3.3 Resilient rail fastening systems - concrete sleepers – ballasted track

In cases of usage of resilient rail fastening for concrete sleepers, the following suppliers and products are available: Pandrol 'e' Clip (Figure 5 left) and FASTCLIP (Figure 5 middle), Vossloh 'SKL14' tension clamp (Figure 5 right).

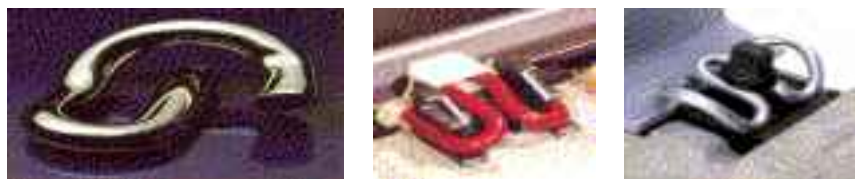

Figure 5 Resilient rail fastening for concrete sleepers

Principal orientation on the 'Serbian Railways' network is the installation of prestressed concrete sleepers with resilient rail fastening on both new and reconstructed tracks whenever it is possible. For mixed traffic railway lines (both passenger and freight traffic), when the 49E1 rail type should be installed, concrete sleepers should be 2,40m long with vertical rail inclination of 1:40. This combination of rail and sleeper fulfils all necessary criteria for the 49E1 rail type, and also has better influence on the substructure due to the weight. With the 60E1 rail type, sleepers should be 2,60m long with vertical rail inclination of 1:40. This criterion has been adopted by almost all European railway administrations.

Considering large quantity of sleepers (1667 pcs per km of rail), despite the small difference in price between the 2,40m and 2,60m long sleepers, total cost difference can be significant. Elastic fastening for concrete sleepers is practically the same for both sleeper types. But, it must be considered that there are places across the line(track) where wooden sleepers will also be installed and in such cases it is recommended that the same type of fastening is used (elastic, not rigid).

The Pandrol FASTCLIP system is a resilient, threadless rail fastening system for application on concrete, steel and wooden sleepers. The unique switch on – switch off of rail clip enables fast track installation and reduced maintenance costs. FASTCLIP has been designed as a system in which all components are delivered to the construction site pre-assembled on the sleepers. Once the sleepers are laid and the rail installed, the clip is simply pushed onto the rail foot either by using hand tools or by mechanized process. FASTCLIP system content cast shoulder insert in sleeper mould before concrete is cast, with same modulus of elasticity as concrete and with same life time as sleeper itself. FASTCLIP system is completely electrically insulated. Change of the track gauge is achievable by using insulators with different thickness. FASTCLIP can be used in curves with minimum radius of 80m.

VOSSLOH w 14 system is resilient for application on concrete sleepers having SKL 14 tension clamp and screw spikes which connect them to the sleeper with plastic dowel inserted in sleeper mould before the concrete is cast. Fastening force of the tension clamp on the rail foot is obtained by tightened of the screw spike with torque of approx. 250 Nm either by using a hand tool or mechanized process. All components can be pre-assembled in the sleeper factory and delivered to the construction site. w 14 system is completely electrically insulated. Gauge adjustment of +-10 mm in steps of 2,5 mm is available. The screw spikes merely have to be loosened but not disassembled. System w 14 can be adjusted in height by using regulating plates.

### 3.4 Resilient rail fastening systems – hard base (slab track)

The application of a track construction on the hard base (so called 'slab track') has its advantages in shallow city tunnels, where it is especially important to prevent transmission of

vibrations to the foundations of neighbouring buildings and appearance of irritating secondary noise. In these cases solutions with track on the concrete slab are applied, as well as in cases of passenger station tracks and on places where limited superstructure height is demanded (e.g. reconstruction due to electrification). There are several systems in usage: Pandrol VANGUARD and Pandrol VIPA and Vossloh System 300 with SKL 15 tension clamp - standard fastening on the DB network for slab tracks, Vossloh system 1403, 336.

#### 4 Overview of the sections of the 'Serbian Railways' network with the resilient rail fastening installed

In accordance with the determination and the wish of 'Serbian Railways' to modernize and revitalize the railway network, resilient rail fastening has found its application. Recognized world manufacturers showed their interest for participation in 'Serbian Railways' network, so these are the following installations:

Railway line – section (from km to km )	Installation Fastening type-manufacturer	Installation year
Line:Beograd-Mladenovac-Niš (from km 15+246 – to km 15+306 st. Resnik – st. Pinosava)	K-Lock Pandrol	2003.
Line:Resnik-Vreoci-Valjevo (Resnik-Stepojevac)	SKL12, SKL14 Vossloh	2004
Section: Niš-Dimitrovgrad Section:Kusadak-Velika Plana	SKL12, SKL14 Vossloh	2003
Line: Beograd – Novi Sad Section: Čortanovci-Petrovaradin	SKL12, SKL14 Vossloh	2005
Line:Beograd-Bar (from km 51+605 to km 51+671 Lazarevac-Lajkovac)	Fast-Clip Pandrol	2004
Line:Beograd-Šid-state border Section: Batajnica-Golubinci	SKL12, SKL14 Vossloh	2009
Section: Beograd Centar	Fast-Clip,VIPA-SP,Vanguard Pandrol	2010

Installations of Pandrol (UK) fastenings were done according to the issued directives from Serbian Railway Directorate: Directive 345 from 1988 for 'e' Clip , Directive 344 from 2002 for Fast-Clip , Directive 343 from 2004 for K-Lock, and from 2010 for VIPA-SP and VANGUARD. Vossloh rail fastening systems (Germany) have been installed according to the technical specifications of the manufacturer, with the prepared Draft of the Directive (from 2009), but it is still without Directive on usage from Serbian Railway Directorate.

During the exploitation period it was noticed by 'Serbian Railways' representatives that resilient rail fastening Vossloh on certain sections got loosen, while with measuring trolley track widening has been found up to 25mm. Having in mind the necessity for installation of resilient rail fastening in the countries with existing small track curve radius (less then 350m), it is recommended by the manufacturer to extend the gauge (see GENERAL CONDITIONS under the Draft of the Directive for delivery, installation and maintenance of resilient rail fastening system 'VOSSLOH').

As for resilient rail fastening system from Pandrol, which has been in service from 2004 in the test section with radius R=500, there were no additional interventions and track gauge irregularities. Since there is no sufficient number of test sections on the 'Serbian Railways' network with the installed Pandrol rail fastening system, we still can't give a complete analysis of the behaviour and quality of these systems.

## 5 Conclusion

Author's intention was to give a short demonstration of parameters influencing the selection of resilient rail fastening systems and experiences gained on the sections on „Serbian Railways“ network, without preferring any advantages and disadvantages of mentioned manufacturers. It can be said that based on the previous measurements and tests during the exploitation period, maintenance is almost minimal. Complete elastic connection is made between rail and sleeper with the elastic spring, i.e. tension clamp. Technical-economical analyses have shown justifiability of application of the resilient rail fastening during the future construction of new high speed railway lines and reconstruction of existing ones, because faster and more comfortable traffic, i.e. increase of railway attractiveness for both passenger and freight traffic, as main goals have been achieved.

## References

- [1] Tomičić-Torlaković, M. & Ranković, S.: Railway superstructure, Belgrade, 1996.
- [2] Milojković, T.: Railway superstructure, Belgrade, 2003.
- [3] Official correspondence of RS departments, RS Commission reports and meetings minutes from 2005 to 2011
- [4] DIRECTIVE 343 for delivery, installation and maintenance of elastic rail fastening "PANDROL" – K – LOCK on the YUR network, Belgrade, 2004.
- [5] DIRECTIVE 344 for delivery, installation and maintenance of elastic rail fastening "PANDROL" – FASTCLIP on the YUR network, Belgrade, 2002.
- [6] DIRECTIVE for production, installation and maintenance of elastic rail fastening PANDROL VIPA-SP on the YUR network, Belgrade, 2010.
- [7] DIRECTIVE 345 for delivery, installation and maintenance of elastic rail fastening "PANDROL" on the YUR network, Belgrade, 1988.
- [8] Draft of the DIRECTIVE for delivery, installation and maintenance of elastic rail fastening system "VOSSLOH" KS and W14 on the RS network, Belgrade, 2009.
- [9] Course: "Contemporary superstructure constructions", Theme: "Rail fastening: types, characteristics, specificities for different pads", Belgrade, 2006.





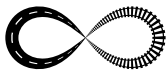

## FWD APPLICATION TO RAILWAY TRACK–BED LAYERS CHARACTERIZATION

Simona Fontul<sup>1</sup>, Govind Kamlesh<sup>2</sup>, Francesca De Chiara<sup>3</sup>, Eduardo Fortunato<sup>1</sup>

<sup>1</sup> National Laboratory for Civil Engineering–LNEC, Portugal

<sup>2</sup> Instituto Superior de Engenharia de Lisboa ISEL, Portugal

<sup>3</sup> 'Sapienza' University of Rome, Italy

### Abstract

The evaluation of the railway track condition represents one of the most significant parts of maintenance planning. Generally, only the track geometry is measured and then, during the maintenance process, the parameters of the track layout are restored, through tamping and levelling processes. Nevertheless, one of the main causes of track geometry deterioration is related to the track–bed condition. An evaluation of track stiffness can contribute to identify foundation problems and to adopt adequate maintenance actions.

In order to identify structural problems, a continuous monitoring of the track through non–destructive load tests can be performed. The Falling Weight Deflectometer (FWD) equipment is commonly used to evaluate pavement's condition and, due to its advantages, has been recently used also for railway platform evaluation. Thus, various FWD tests were performed during the construction of a new railway section, designed for high speed traffic. Three test campaigns were undertaken on different months, aiming to study the climate effect, and also different load levels were applied on each test point, in order to analyse the non–linear response of the track–bed layers to load level.

Based on the FWD tests results, the elastic moduli of the track–bed layers are back–calculated and, consequently, the stiffness variation along the track can be estimated. This enables the identification of possible settlements caused by foundation.

The main results obtained so far are presented in this paper, together with proposals for future developments.

*Keywords: railway platform, non destructive tests, loading tests, Falling Weight Deflectometer, back–calculation*

### 1 Introduction

The railway evaluation consists generally in monitoring the geometry of the track with dedicated equipment that performs the measurement without contact with the track elements. Based on the results obtained, any track settlements or rail geometry problem detected is solved through tapping and levelling. This process consists in adding more ballast to the existing track in order to re–establish the initial geometry. However, this process does not solve the real causes of the track settlements, such as fouled ballast or drainage problems [1, 2]. In these cases, the tapping will only increase the settlement due to increased weight. The Falling Weight Deflectometer (FWD) is usually applied for pavements evaluation. Several tests were performed at subballast level in order to study the applicability of this equipment to railway evaluation. The troubleshooting and the main results obtained so far are presented herein.

## 2 Falling Weight Deflectometer

The Falling Weight Deflectometer (FWD) is presently the device for deflection testing most widely used in Europe, North America and Japan [3, 4] for pavement evaluation. The test load is obtained by dropping a weight from a certain height on a set of buffers. The load is transmitted to the surface through a metal plate and the resulted deflections are measured by transducers resting on the surface, up to about two meters distance from the load centre. This equipment has the advantage that the impact load applied on the surface can be changed by changing the weight, the height and the loading plate diameter. In this way, simulation of various loading levels is enabled. The equipment measures the structure response in 6 to 9 points (see Figure 1), resulting a deflection bowl that reflects the influence of different layers on the structure response.



Figure 1 Falling Weight Deflectometer equipment.

The measurements are performed at equal distances along the infrastructure studied, chosen according to the length of the section to be tested (from 10 to 100 m). The measured deflection bowls, together with the information on layer thickness, are used for the estimation of 'in situ' bearing capacity [3, 4].

## 3 Load tests on a track platform – case study

### 3.1 General description

The case study consist of a structural modeling of an experimental field site of a railway infrastructure [5, 6], based on non-destructive load tests performed with FWD at the top of sub-ballast granular layer. In this way, an analysis of the efficiency of the load tests and their applicability and variability was made.

FWD load tests were performed at the top of sub-ballast, different load levels were applied in order to study the response of the structure and to establish the testing methodology. Different testing campaigns were undertaken, in different months, in order to identify the structural response under different weather conditions, consequently water contents. Several load levels were applied in order to study their influence on the measured deflections.

The FWD 0.30 m diameter plate was used and minimum 3 drops were applied at each test point. The deflections were measured by nine transducers, one central (do) and the remaining eight away from the center of the load plate by 30, 45, 60, 90, 120, 150, 180 and 210 cm. A brief presentation of the tests performed and the main results obtained [5] are referred herein.

### 3.2 Track section studied

The load tests of the case study were performed in a 29 km new railway section constructed in Portugal [5]. The recommendations of uic 719R [7] were followed, for the design of the platform, in order to meet the requirements for the high-speed traffic. In this case study six sections (S1 to S6) of the railway platform were analysed [6].

The track substructure (see Figure 2) consists in a 0.30 m sub-ballast layer, generally composed by 0.15 m of granite aggregate, well-graded crushed unbound granular material (UGM), as top sub-ballast layer, and 0.15 m of limestone UMG, as bottom sub-ballast layer, except for section 1 (S1) in which both layers consist on granite UGM. Generally, on the top of the subgrade a 0.20 m limestone UGM capping layer was placed, under the sub-ballast, except for section 6, in which the capping layer was 0.35 m thick.

The first five sections (S1 to S5) were built on landfill, with an identical structural solution (Figure 2 left), while the sixth section (S6) was built in excavation and has a different structure (Figure 2 right), as already referred.

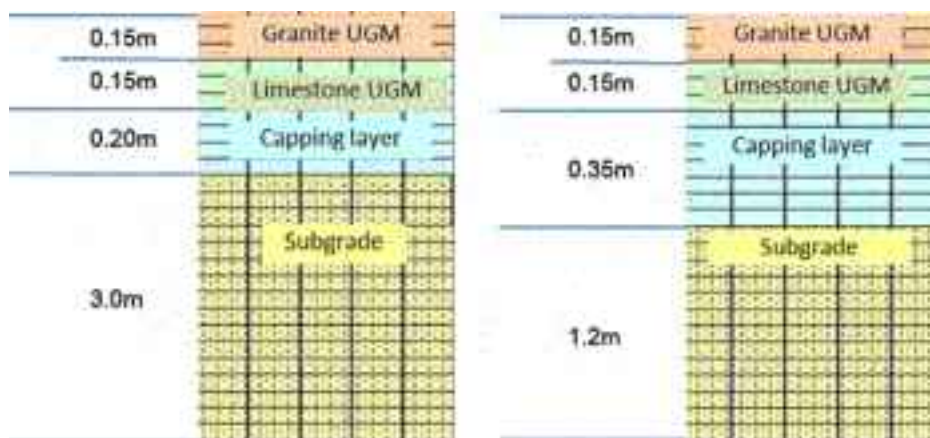

Figure 2 Geometrical characteristics of the track substructures studied

### 3.3 Load tests performed

Tests were carried out in six sections studied (S1 to S6), at the top of the sub-ballast layer, in November and December of 2008 and January of 2009.

Figure 3 presents, as an example, the deflections obtained in Section S6 during the December campaign, for several loading levels carried out, corresponding to 16, 25, 65, 90, 110 and 130 kN.

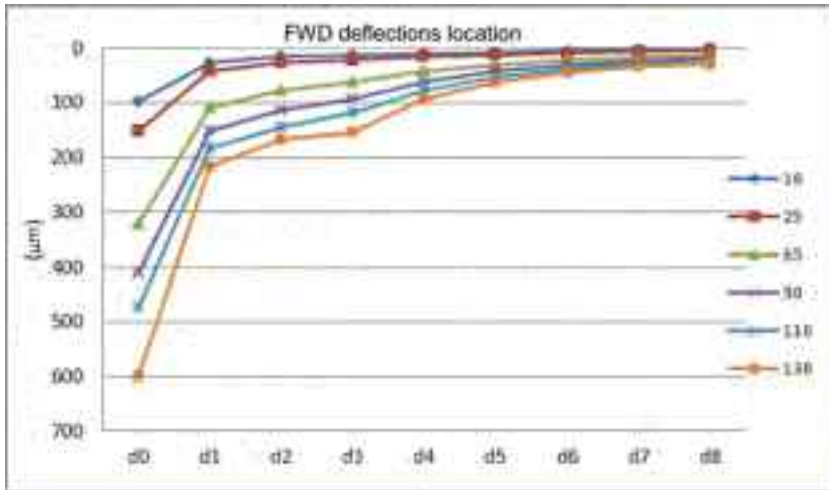

Figure 3 FWD deflection obtained for various load levels at Section S6

### 3.4 Analysis of the results

From the analysis of FWD tests results for different loading levels resulted that, generally, the values of the granular layers modulus ( $E_1$ ) tend to increase with increasing loading level, except for the highest load (130 kN), where there is a decrease in  $E_1$  modulus (see Figure 4) but at the same time an increase in  $E_2$ .

It can be also observed that the subgrade layers modulus ( $E_3$ ) tends to decrease with the increase of load. The rigid layer modulus ( $E_4$ ) was maintained constant during this analysis.

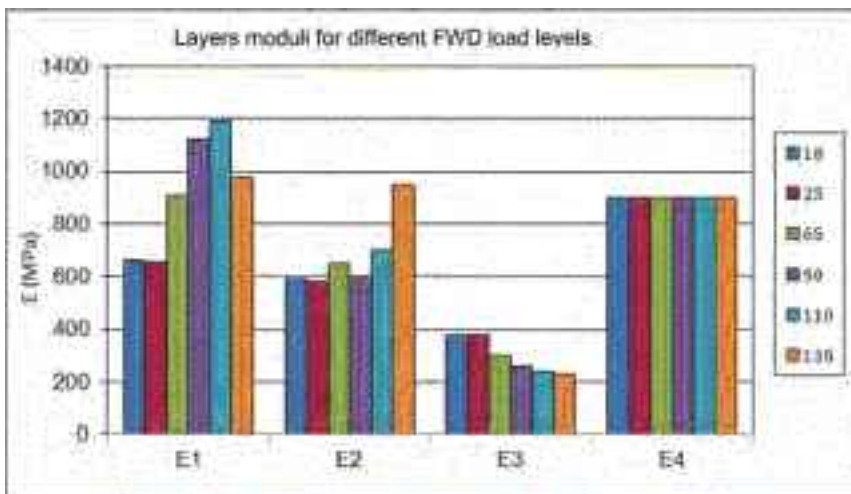

Figure 4 Back-calculated moduli for different load levels – Section S6

The analysis of the results obtained for the three test campaigns undertaken in different months (November and December of 2008 and January of 2009) shows that the moduli obtained for the first five sections (S1–S5) are similar per campaign, with small variations (see Figure 5).

In the temporal analysis (Figure 6), it is found that the modulus E1 in November tends to be equal to the modulus E2, with minor variations. However, in December and January, the E1 moduli are generally lower than E2 moduli, with greater differences observed in January. This fact may be caused by the significant amount of precipitations that occurred in December and January.

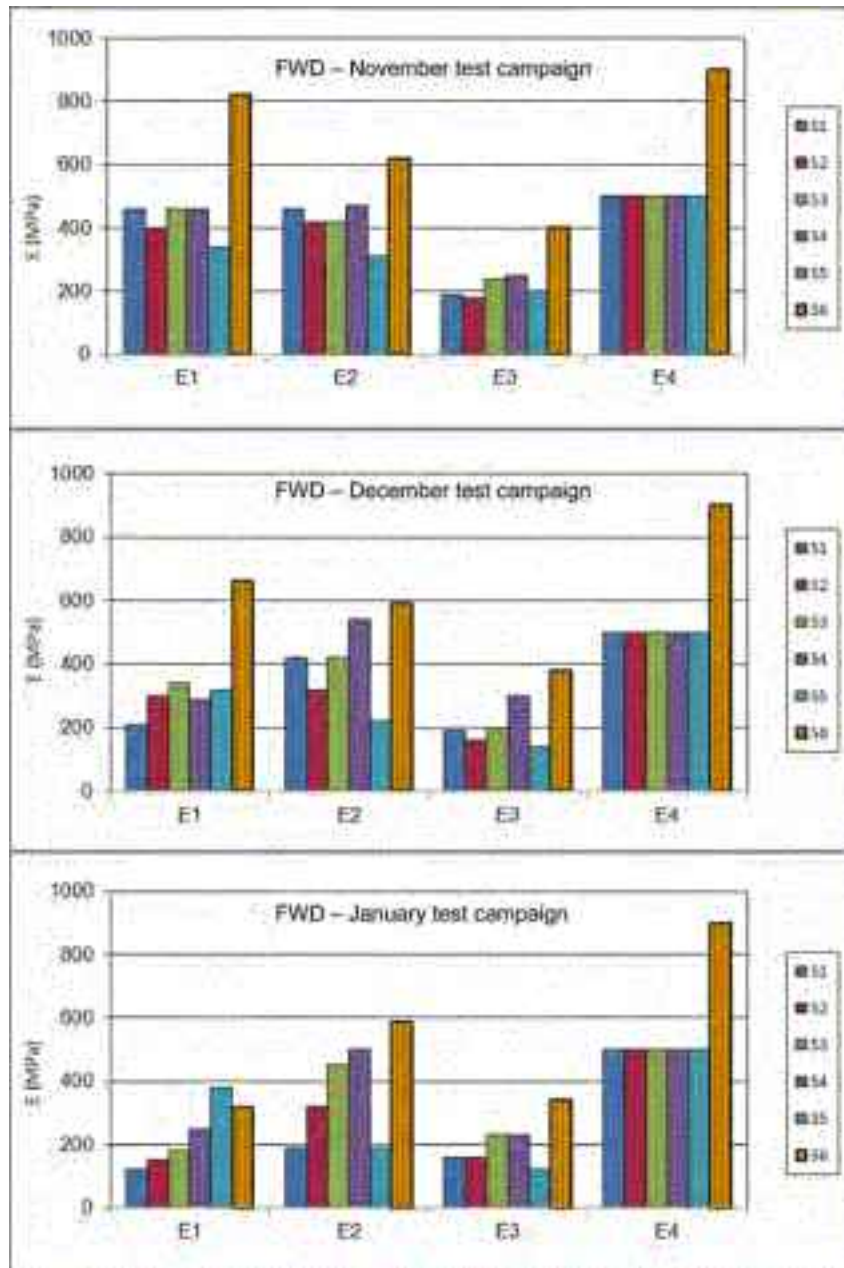

Figure 5 Back-calculated moduli during different test campaigns S1–S6

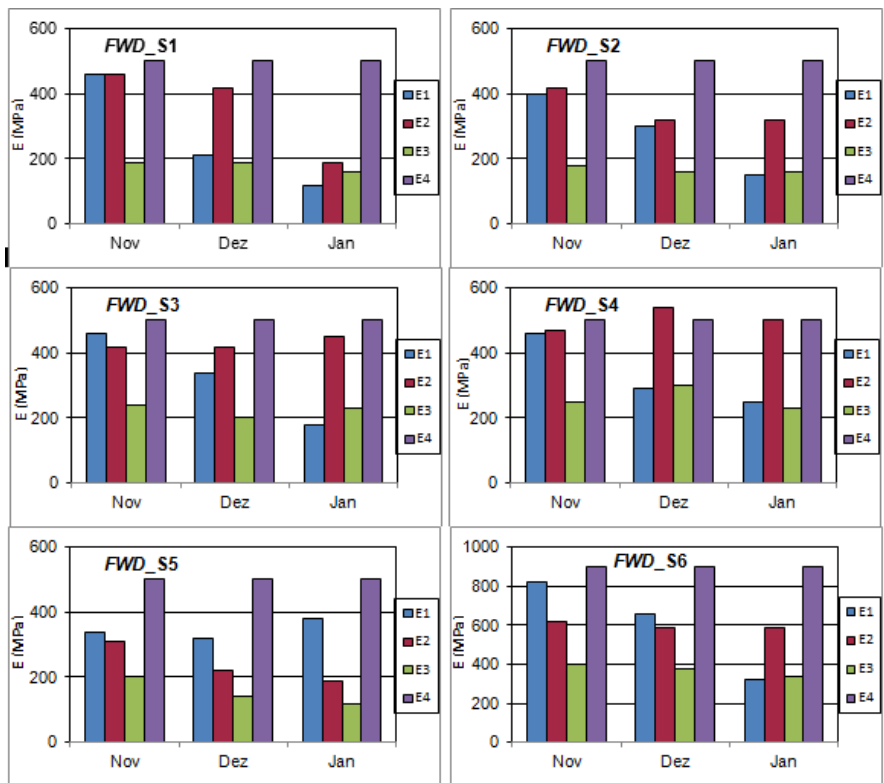

Figure 6 Back-calculated moduli during different test campaigns

## 4 Final considerations

The application of non-destructive load tests has proven to be an efficient way to obtain continuous information of the platform condition. Several tests were performed in different months during the year and with different load testing levels in order to define the better testing approach for the railway platform evaluation.

Some of the results obtained for structural characterisation of a test section are presented in this paper.

It is expected with this approach to contribute to a better characterisation of the platform, by using the FWD results, as they allow determining the elastic moduli of distinct layers of the track platform. In this way, it is possible to identify the causes of stiffness variation along the infrastructure and to correlate the future in service behaviour with the real causes of possible pathologies, such as track settlements.

As future developments, based on the tests performed during this study it will be possible to define testing procedure for FWD measurements, to study the substructure response under different load levels and water contents conditions and to correlate the test with other loading tests performed in situ, such as Portable Falling Weight tests and Plate Load Tests.

The next step is to develop testing procedures at the top of the railway track that enable the correlations of data obtained during construction with the structure response during service. In this way it will be possible to follow the track condition under traffic loading.

## References

- [1] Burrow, M.; Chan, A. & Shein, A.: Deflectometer-based analysis of ballasted railway tracks, Proceedings of the Institution of Civil Engineers: Geotechnical Engineering, 160, 169-177, 2007.
- [2] Fortunato, E: Renovação de plataformas ferroviárias - Estudos relativos à capacidade de carga (in Portuguese), PhD Thesis, Porto, Portugal, 2005.
- [3] Fontul, S.: Structural Evaluation of Flexible Pavements using Non-Destructive Tests, Ph.D Thesis, Lisbon, 2004.
- [4] Fontul, s. & Antunes, M.L.: Optimising the Use of non-destructive tests in pavement evaluation, 9th International Road Conference Budapest, Roads for Sustainable Development, Budapest, Hungary, 2006.
- [5] Fontul, S., Fortunato, E. & De Chiara, F.: 'Non destructive tests for railway infrastructure stiffness evaluation', The Thirteenth International Conference on Civil, Structural and Environmental Engineering Computing and The Second International Conference on Soft Computing Technology in Civil, Structural and Environmental Engineering; Chania, Crete, Greece, 6-9 September 2011.
- [6] Kamlesh, G.: Caracterização estrutural de infra-estruturas de transportes através de métodos de auscultação não destrutivos, (in Portuguese) Master of Science Dissertation, ISEL, Lisbon 2010.
- [7] UIC CODE 719R, Ouvrages en terre et couches d'assise ferroviaires; Paris: Union Internationale des Chemins de Fer (1994).





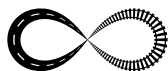

## TRANSITION ZONES ON THE RAILWAY TRACK – OVERVIEW

Marko Vajdić<sup>1</sup>, Irina Stipanović Oslaković<sup>2</sup>, Stjepan Kralj<sup>1</sup>

<sup>1</sup> Institut IGH d.d., Croatia

<sup>2</sup> University of Twente, Construction Management and Engineering, The Netherlands

### Abstract

Transition zones between bridges, tunnels, artificial and earth structures, including transitions between ballast and non-ballast permanent way (slab track), are a part of the railway track structure where the abrupt change in the rigidity of the track structure and track settlement occurs between individual transverse profiles, as a result of the change in the structural elements and the foundation. Variation in the rigidity of the rail structure is the basic parameter influencing the generation of new impulse mechanisms during interaction between the vehicle and the structure. This causes additional dynamic loads, resulting in further degradation of the track structure and indirect decrease in the level of safety and comfort of railway traffic. Due to foregoing, the transition zones are defined as exceptionally problematic parts on the railway track. In order to limit additional and frequent costs of rehabilitation of these track parts, the degradation mechanisms are analyzed within EU funded research project (SMART RAIL), with the aim to find a high-quality, economically and environmentally acceptable solution for existing older railways.

This paper presents the mechanisms influencing the degradation of tracks in the transition zones, as well as structural measures presently known and used for rehabilitation of existing railways.

*Keywords: transition zones, degradation of the railway track, structural measures*

### 1 Introduction

One of the basic objectives of the present railway authorities refers to the reduction of maintenance costs allocated for maintaining the railway infrastructure. Due to the frequent need for conducting additional maintenance and reconstruction, which are disproportional compared to other sections of the railway track, several European railway authorities define the transition zones between the 'normal' open tracks and 'rigid' track systems or substructure such as bridges/ tunnels/ culverts as problematic parts on the track. In the Netherlands, intervention frequency at transitions is up to 2–4 times those on the open track, [1].

Frequent repairing of the places like these has resulted in reduction of the track capacity and traffic continuity, which generates additional costs to the railway authority.

With the aim of reducing both direct and indirect costs of maintenance of such places to an optimal level, taking into account the increase in safety and comfort of rail services, the issue of transitional zones demands more attention, which was recognized within SMART RAIL consortium and set up as one of the main goals.

## 2 Transition zones

Transition zones are defined as parts of the railway track where a change of basic characteristics that define a railway structure in its entirety takes place.

Under the basic characteristics following parameters are considered: substructure and superstructure stiffness, deformation of each substructure layer and each superstructure part, overall value of track deformations, geometric restraints.

The transition zones in general represent the appearance of discontinuity in the track structure, as shown in Fig. 1.

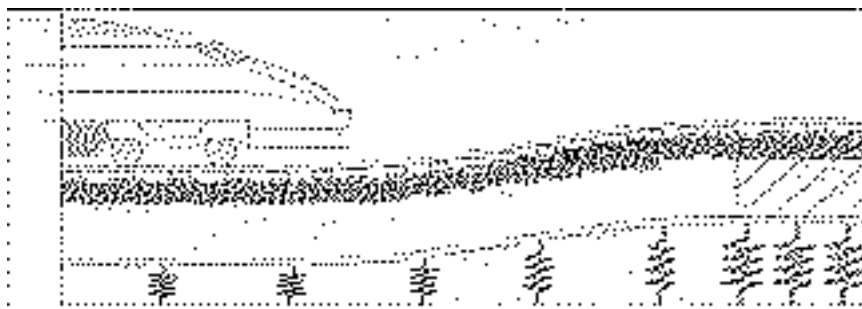

Figure 1 Transition zones – discontinuity in the track structure, [2]

Type of the transition zone depends on where it is located, [3]:

- transition between different types of superstructure (from slab track to ballasted track or reverse)
- transition from one type of substructure to another:
  - transition between embankments and bridges/viaducts
  - transition between embankments and tunnels
  - the track above the shallow built culvert
  - transition between different types of embankments
- direct transition between two different types of rigid substructures:
  - transition from tunnel to bridge/viaduct
  - transition between two different types of bridge structures

## 3 Negative mechanisms that occur in the transition zones

Poor condition of the transition zones is a consequence of numerous complex and interrelated mechanisms. In order to find the best possible solution for solving the problems that happen in the transition zones, all the negative mechanisms which influence the behaviour of the track structure should be taken into account and analysed.

Analysis and identification of the basic causes of degradation of the track structure in the transition zones have been performed in this decade only, as a result of constant efforts to reduce maintenance costs, with transition zones representing a significant potential and opportunity for contributing to this reduction of both direct and indirect cost (e.g. resulting from train delays and loss of capacity) of maintenance. [1]

### 3.1 Discontinuity in the stiffness of the track structure

The basic negative attribute which is characteristic for the transition zones is the discontinuity in the stiffness of the track structure.

The diagram in Fig. 2 shows the deflection profile of measured results which were obtained with the help of the measuring vehicle. The results were obtained after a surfacing mainten-

ce operation, when the unloaded track profiles were impeccable. Nevertheless, as illustrated in Fig. 2, in the transition zones we still have large and variable track deflections under load, indicating an apparent factor contributing to poor vehicle/ track interactions. Deflection results shown in Fig. 2 include not only contribution from the ballast, subballast, and subgrade layers, but also contribution of possible gaps and slacks between sleepers and ballast, which would close under the loaded condition, [4].

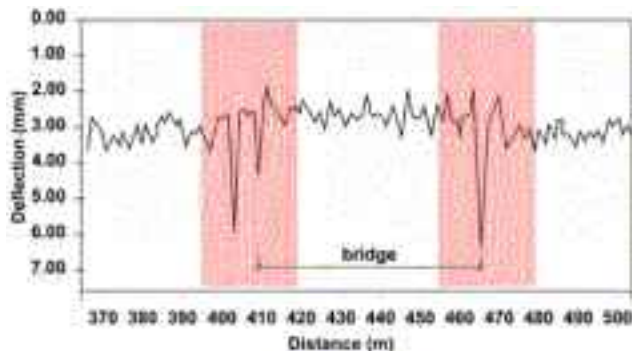

Figure 2 Loaded track deflection profile, [4]

The diagram in Fig. 3 shows the measured results of track modulus which are obtained on the concrete bridge with ballast deck and their transition zones (from both sides). As shown, the track structure on the concrete bridge has high stiffness characteristics compared to other parts of the track. On average, the measured track modulus on the bridge was  $68.95 \text{ N/mm}^2$ , which is too high to accommodate desirable vehicle/track dynamic interaction. In addition, the change of track stiffness between bridge and approach was also too high (almost double on average), [4].

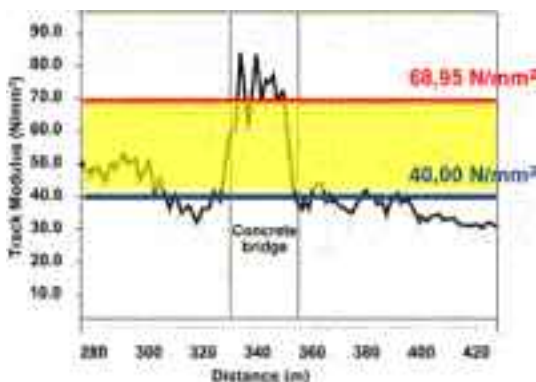

Figure 3 Track modulus test results, [4]

### 3.2 Differential settlements of the rail track structure

Studies have shown that the settlements of the rail track at the transition zones are much larger than those on the open track, or the one on the bridges and in the tunnels, [1]. Track settlement on the open track section can be very variable due to variety of the geotechnical parameters. Geotechnical disadvantages such as poor bearing capacity of the foundation soil, poor initial compaction/consolidation of the embankment and foundation soil, erosion

as a result of poor solutions of the drainage system and inadequate drainage system of the foundation soil further contribute to negative occurrences of differential settlement. Natural factors such as wet/dry and cold/ warm cycles also affect the level of settlement of the substructure.

In addition to geotechnical imperfections, the settlements can occur also because of poor performance, inadequate application of fill material, as well as bad judgment or a sudden increase of traffic load.

For the foregoing reasons, the differential settlement is considered to be the following negative characteristics typical for the transition zones.

Fig. 4 shows comparative test results of average track settlements on four different railway bridges and their approaches. As may be read out from the diagram, the track segment right before and right after the bridge is affected by most intense track geometry deformations in comparison with track structure on the bridge itself or the one on the open part of the route. Track structure settlements on a bridge are about 25% less severe than settlements which appear in transition zones, [4].

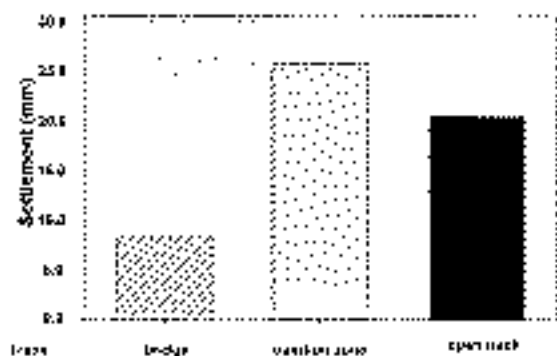

Figure 4 Test results of average track structure settlements on four different railway bridges and their approaches, [4]

### 3.3 Influence of rail services speed

The impact zone of the above mentioned negative mechanisms depends also on the trains operating speed. As the train speed increases, the zone of negative dynamic effects becomes longer. It is recommended that the minimum length of the transition zone is, [5]:

$$L_{\min} (m) = v_{\text{train}} \left( \frac{m}{s} \right) \times 0,5(s) \quad (1)$$

### 3.4 Influence of the direction of the train

A sudden change in the vertical track structure rigidity causes the wheel of the vehicle to go through the same sudden change along its height due to uneven deflection. This change in elevation causes vertical acceleration of the vehicle mass, which generates an increase of the existing load by the value of the newly–formed impact dynamic load, [2].

This is why each track degradation mechanism is different, depending on the direction of the trains.

### 3.5 Mutual interaction of negative mechanisms

The above-mentioned degradation mechanisms, which in fact act each on their own, may also be conditioned by each other. For an example, geotechnical deficiencies may cause differential settlements of the ballast or subgrade, which reduces the structure rigidity and as a consequence generates larger dynamic impact loads, which in turn intensifies ballast degradation and settlement of the track substructure.

Cyclic repetition of these processes accelerates degradation of track geometry, with reduced quality and safety of driving as an immediate consequence.

## 4 Transition zones

A certain structural solution is in fact hidden behind the term 'transition zones'.

The main task of transition zones is to prevent sudden changes in stiffness of the load-bearing structural elements of the track. The aim is to minimize/ or prevent the occurrence of additional negative dynamic loads over a part of a transition zone, which additionally accelerate the track geometry degradation, with reduced quality and safety of driving as an immediate consequence. This can be achieved by linearly changing certain properties of the surrounding structures at a reasonable distance by dividing one differential change into smaller steps, i.e. dynamically irrelevant intervals.

Ideally these inconsistencies occurring in parts of transition zones do not influence the performance of a passing train in terms of safety but rather they more often reflect upon the quality and comfort of rail services and other dynamic occurrences, [6].

Different railway authorities have approached the solution to the transition zones issue differently. The reason for this lies in the fact that there is no single unique solution which would adequately solve every problem. Transition zones are complex constructions which require an individual approach in design engineering in terms of their location and type.

Various approaches to solving this issue have been proposed, with emphasis either on increasing track structure stiffness in a transition zone or on reducing track structure stiffness on a bridge/tunnel/culvert/modern slab track. All the proposed solutions are based on gradual linear adjustment of stiffness of the load-bearing base in the transition zone in order to avoid discontinuity in track structure rigidity, [7].

### 4.1 Design of transition zones

Two characteristics are commonly considered when designing a transition, which are, [6]:

- Differential Settlements – Settlements are slowly but continuously emerging plastic deformations of a structure, usually resulting in small but dynamically relevant changes in a structure's dimensions.
- Differential Stiffness – Stiffness is a value of a structure's deformation under live loads. A train (representing a live load, thus causing a certain deformation) when passing structures of differential stiffness is exposed to a dynamic reaction, usually resulting in a noticeable acceleration of the coach.

Transitions shall be designed by making variations gradually in both the settlements and the stiffness, so that both safety and comfort conditions are achieved. Furthermore, transitions shall not be subject of increased maintenance requirements but should ideally be coordinated with the rest of the tracks.

Design of the transition zone is performed separately for the substructure and for the superstructure of the track, [6].

In recognition that the installation of good quality rails, fastening systems, railway sleepers and ballast will have little effect if the substructure of track does not have adequate bearing capacity and stiffness design, maintenance and reconstruction planning of the sub-structure must be given equal importance as to the superstructure.

## 4.2 Compensation of differential settlements

Structural parts of the track structure on the open part of the route, such as embankments and ballast, are most often prone to settlements.

### 4.2.1 Compensation of differential settlements of the ballast

Stabilization of the ballast may be conducted by applying various structural solutions:

- application of different types of sleepers, [2,4,6,11]
- application of additional rail, [2,3,6,11]
- application of ballast 'glue', [15,16]
- application of the ballast and sub-ballast mats, [20,21]
- application of the concept of lateral reserved ballast – ballast casing, [4]
- 

### 4.2.2 Compensation of differential settlement of the embankment

With structures such as tunnels, bridges and viaducts there are usually no problems with settlements, and it may therefore be assumed during the design phase that indeed no settlements will occur.

In case of earthen structures, such as embankments, the occurrence of differential settlement cannot be completely ruled out and therefore certain predictions shall be made, most often based on rough estimates.

The measures most often taken are as follows:

- stabilization of the embankment (in compliance with the recommendations from UIC CODE 719R), [8],
- separation of the tunnel/bridge/viaduct structures from the embankment, and
- securing of their free ends.
- 

The last two measures are implemented with the aim to prevent transfer of negative impacts from one structure to the other.

Each railway authority approaches the embankment differential settlement compensation issue independently. The Figures in UIC CODE 719R illustrate the exact diversity in structural solutions for transition zones divided into particular railway authorities in Europe, [8].

In case of embankments elevated on foundation soil with low bearing capacity, the issue of the foundation soil bearing capacity should be solved first, using standard geotechnical solutions for improving its mechanical properties, [9]:

- gravel piles – vibratory compaction
- vibrated concrete columns
- soilfrac process
- micropiles, [4]
- jet grouting, [19]
- 

A properly designed and constructed base shall have nominal stiffness's adequate for the proposed traffic loads, and it shall fulfill its task equally well under wet and dry conditions, so it would not be prone to differential settlement.

In case of a transition zone between two different permanent way systems, a standard ballasted one and a modern ballastless one, on a particular embankment with a particular structure, it may be assumed that the traffic load, as well as its distribution through structural load-bearing layers of certain track structure systems, are similar or nearly identical, which leads to the conclusion that embankment settlement is the same in both track structures, and it doesn't need to be compensated for, [6].

### 4.3 Compensation of differential stiffness

A linear change in rigidity between two different track structures may be achieved by performing the following:

- application of fastening systems with different stiffness properties, [22]
- adjusting of the stiffness in the track bearing layers, [3,6,11]

Due to modern fastening systems and a variety of elastic mats intended for track structures on a rigid base, the overall rigidity of the ballast track structure and track structure on a rigid load-bearing base become mutually comparable and similar, meaning that the difference in stiffness doesn't need to be compensated any longer by certain additional construction measures.

## 5 Future efforts – SMART RAIL Project

A first step towards efficient and optimized design and maintenance is the modeling of track settlement and track/ foundation stiffness. In both cases, the models will be integrated with existing and new methods of monitoring current condition.

Simulation of nonlinear behavior of track structure elements in a transition zone is attempted by applying the finite element method.

A train-track interaction model will be developed to consider the response of railway infrastructure to loading. The objective is to find a way towards a structural solution of the transition zone issue by developing 3D models, integrating the time variable and specifying realistic boundary conditions in order to simulate the behavior of a track structure.

Development of a 3D model is preceded by an adequate and comprehensive monitoring of on-site activities. It is necessary to collect proper input parameters in order to calibrate the model as well as possible, and thus adjust it to a particular micro-location.

The results of such analyses will improve the existing models and determine specifications for new structural solutions for transition zones. Within SMART RAIL project researchers are focused on the transition zone problem areas, and based on several typical case studies will try to develop unique recommendations for the design and rehabilitation of the transition zone on the existing railway lines, [12].

## 6 Conclusion

Transition zones represent discontinuity in track structures. Many studies have indicated that sudden changes in track structure stiffness in transitions over culverts or transitions from an open part of the route onto a bridge/ viaduct/ tunnel is the main reason for the degradation of track structure in those sections.

The higher the axle load is, as the traffic load increases and as the train speed is higher, the more urgent is the transition zone issues.

When designing a new route, the transition zone issue is in most cases considered tough problem, where typically following questions are occurring: What is the required length of the transition zone, and which transition zone system to apply? There are many different solutions to this problem available in expert reading materials. However, there are currently no specific recommendations for dimensioning and designing of the transition zones in Croatia where many projects for the rehabilitation and improvement of existing railway are planned or already on going. Based on the experience from the road construction, research results, laboratory and on-site measurements, case studies where new solutions will be implemented, guidelines for the rehabilitations of transition zones on the existing railways will be developed, [12, 18, 23, 24].

In order to reduce costs generated through frequent rehabilitation of such parts of the route, all mechanisms which impact track structure degradation in transition zones should be



analyzed in detail in order to find an adequate solution in terms of special construction measures for solving this issue, and in order to develop the required technical conditions for dimensioning and designing.

Rehabilitation designs for the existing structures as well as designs for the new structures should take transition zones into account and offer a solution for them, namely transition zones should become an integral part of a structure's design documents.

## References

- [1] Coelho, B.; Hölscher, P.; Priest, J.; Powrie, W.; Barends, F., (2011). An assessment of transition zone performance, *Proc. IMechE: Part F: J. Rail and Rapid Transport*, 225:2, 129-139.
- [2] Esveld, C.: *Modern Railway Track*, Second Edition, TU Delft, 2001.
- [3] Rossmann: *RHEDA 2000® Transitions*, Rail One, Brno, 2009.
- [4] Jenks, C.W.: *Reserch Results Digest 79 - design of track transitions*, Washington, 2006.
- [5] *Vertical Elasticity of Ballastless Track*, UIC, Paris, 2008
- [6] Rossmann; Nawrat: *Transition areas: Ballastless - Ballasted Track*, Neumarkt. 2008.
- [7] Sasaoka, C.D.; Davis, D.D.: *Implementing Track Transition Solutions for Heavy Axle Load Service*, 2005.
- [8] *UIC CODE 719R: Earthworks and track bed for railway lines*, UIC, Paris, 2008.
- [9] Mikulić, J.; Stipetić, A.: *Railway track structures*, Zagreb, 1999., (in Croatian)
- [10] Plotkin: *Track Transitions and the Effects of Track Stiffness*, TTCl/AAR, 2006.
- [11] Lichtberger, B.: *Track Compendium*, Eurailpress, Hamburg, 2005.
- [12] Gavin, K., Stipanovic Oslakovic, I., Vajdic, M., Puz, G., Sporic, V.: *Smart Maintenance and Analysis of Transport Infrastructure*, Collaborative project (SMART Rail), will be published in *Proceedings of CETRA 2012*, Dubrovnik, Croatia.
- [13] *Smart Maintenance and Analysis of Transport Infrastructure*, Collaborative project (SMART RAIL), Description of work, FP 7 project number: 285683, Dublin, 2011.
- [14] Dahlberg, T.: *Railway Track Stiffness Variations—Consequences and Countermeasures*, *International Journal of Civil Engineering*. Vol. 8, No. 1, March 2010.
- [15] Lakušić, S.: *The track stabilization with gluing process*, *Dani prometnica: Gospodarenje prometnom infrastrukturom*, Faculty of Civil Engineering, University of Zagreb, 2009., (in Croatian)
- [16] Xitrack, [www.bbrail.com](http://www.bbrail.com).
- [17] Berggren, E.: *Railway Track Stiffness - Dynamic Measurements and Evaluation for Efficient Maintenance*, Stockholm, 2009.
- [18] Radić J.; Mandić A.; Puž G.: *Bridges 2 - Construction of bridges*, Zagreb, 2005. (in Croatian)
- [19] Kvasnička, P.: *Stabilization of track substructure with jet injection*, *Dani Prometnica: Nove tehnologije i materijali*, Faculty of Civil Engineering, University of Zagreb, 2010. (in Croatian)
- [20] Witt, S.: *The Influence of Under Sleeper Pads on Railway Track Dynamics*, Department of Management and Engineering, Division of Solid Mechanics, Linköping University, 2008.
- [21] Gatzwiller, K.B.: *Next-generation Anti-vibration Mats for Modern-day Track Designs: Resiliently Supported Substructures Using RockXolid® and RockBallast®, RockDelta a/s (ROCKWOOL a/s)*, Hedehusene, 2011.
- [22] Vossloh Fastening Systems, [www.vossloh-fastening-systems.com](http://www.vossloh-fastening-systems.com)
- [23] *Identification of the best practices for design, construction, and repair of bridge approaches*, Center for Transportation Research and Education, Iowa State University, Iowa, USA, 2005.
- [24] Lenke, L.R.: *Settlement Issues – Bridge Approach Slabs (Final Report Phase I)*, University of New Mexico, Department of Civil Engineering, New Mexico, 2006.

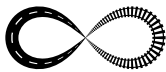

## INFLUENCE OF USPs ON THE QUALITY OF TRACK GEOMETRY IN TURNOUT

**Miroslava Hruzikova, Otto Plasek, Jaroslav Smutny, Richard Svoboda**  
*Brno University of Technology, Faculty of Civil Engineering,  
Institute of Railway Structures and Constructions, Czech Republic*

### Abstract

The under sleeper pads (USPs) bring elasticity into railway superstructure on the underneath surface of sleepers. Decrease of ballast and sub-ballast layers' stress, homogenization of vertical track stiffness, decrease of rail corrugation development in narrow curves and reduction of vibration transmission onto a track bed are expected contributions of this elastic layer. The trial track section with a turnout in which bearers with USP are installed were constructed in the Planá nad Lužnicí railway station (iv. railway corridor: Praha–České Budějovice–Linz) in 2007. The section comprises of the turnout and transition zones with USPs and the appropriate comparative section. The aim is to monitor the influence of USPs to the settlement of bearers in the turnout and to the quality of track geometric parameters.

The trial track section, the methodology of track geometry parameters' monitoring (precise levelling and track measuring car data) and the measurement evaluation are described in this article.

*Keywords: monitoring, track geometry parameters,  
trial track section, turnout, under sleeper pad*

### 1 Introduction

The dynamic effects' increase in railway track structures is connected with the train service speed increase. The dynamic effects occur due to imperfections of a railway track. Vibrations of railway superstructure elements and structure borne noise are caused by the dynamic loads. These vibrations are transferred to the track subsoil and to the track vicinity. The dynamic effects unfavourably influence development of the railway track defects and failures which usually cause changes in track geometry parameters. The ballast bed is the most stressed layer. USPs fixed on the bottom surface of a sleeper decrease the railway track stiffness. The contact area between sleeper and ballast is higher. Static and dynamic loads on sleepers and bearers decrease and vehicle-track dynamic system properties are modified. Also the transfer of vibrations to a ballast bed is interrupted and damping of vibrations is moved to upper parts of the track.

### 2 Description of the trial track section

The trial track section is situated in the Planá nad Lužnicí railway station. It was constructed for the turnout J60–1:12–500-I with USPs in 2007. The assembly of the USPs for the turnout was designed in the mathematical model [2].

The basic bedding modulus of USPs is  $0,250 \text{ N}\cdot\text{mm}^{-3}$ . Softer USPs were used in the crossing panel and in the area of long bearers behind the crossing. The softer USPs are only used on the middle part of the bearers.

The transition zones that allow smooth transition of vertical track stiffness between the track with USPs and the track without USPs were designed. The neighbouring turnout was chosen as a comparative conventional track section. The bedding modulus of USPs in the transition zones is  $0,300 \text{ N}\cdot\text{mm}^{-3}$ . The length of the transition zone is  $32,4 \text{ m}$ , i.e. 54 sleepers. The total length track with USPs is  $205 \text{ m}$ . The pads were glued to the underneath surface of sleepers and bearers. The scheme of the track section is on the Figure 1.

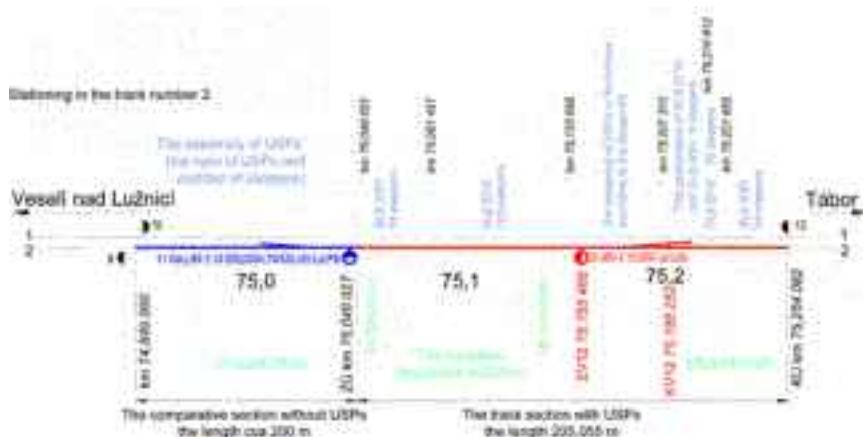

Figure 1 The scheme of the trial track section in the Planá nad Lužnicí railway station

Discrepancies between the assembly design of USPs and its execution (lacking USPs, wrong glued-on USPs) were found out after the turnout had been laid on 9<sup>th</sup> November 2007. Speed restriction was imposed. The discrepancies were repaired on 7<sup>th</sup> April 2008 and the speed restriction was removed after the tamping of the turnout and expiry of consolidation. The tamping was carried out three times in the trial track section April 6<sup>th</sup> 2008 (only the turnout with USP), November 12<sup>th</sup> 2008 (only the turnout with USP) and July 23<sup>rd</sup> 2009.

### 3 Monitored parameters

All the values and events which could be influenced by the use of USPs in the trial track section are being monitored. These are the parameters being observed:

- track geometry parameters quality;
- track settlement;
- vertical deflection under a running axle;
- vibrations of railway superstructure elements;
- transfer to a track vicinity;
- noise propagation to a track vicinity.

This article deals with the track geometry parameters' monitoring by precise levelling and a track recording car. The aim is to verify the stability of the long bearers with USPs. The measured and calculated data from both the precise levelling and track recording car were compared.

### 3.1 Description of the precise levelling measurement

The rail top levels of the track are monitored through a precise levelling. Rail levels, bracket-type datum mark heights and others check points are monitored. Ninety three sections from 74,848 000 km to 75,282 300 km are being monitored in the Planá nad Lužnicí railway station. The sections in the track between the turnouts have the distance of 6 m; the sections in the turnouts have the distance of 3 m. The elevations are in a relative altitude system. Relative deviations from the optimized track position which was found out by regression in the initial observation were calculated. Deviations from designed position, track twists and a progress of track settlement were calculated.

### 3.2 Monitoring of track geometry parameters by track recording car

The track recording car measures and records the following track geometry parameters: track gauge, curvature, alignment, cant, twist and longitudinal level. Measurement deviations of track alignment, longitudinal level and cant were chosen for further processing and evaluation of the trial track section. The track twists were calculated from the cant.

## 4 Evaluation of monitored parameters

### 4.1 Precise levelling [3]

The longitudinal level of the track was measured three times every year after the trial had been put into operation. The trial track section was divided into five interest sections:

- Track without USPs (1): the track without USPs in front of the turnout no. 11 without USPs;
- Turnout no. 11 without USPs;
- Track with USPs (1): the track with USPs between the turnout no. 11 and the turnout no. 12;
- Turnout no. 12 without USPs;
- Track with USPs (2): the track with USPs behind the turnout no. 12;
- Track without USPs (1): track without USPs at the end of the trial track section.

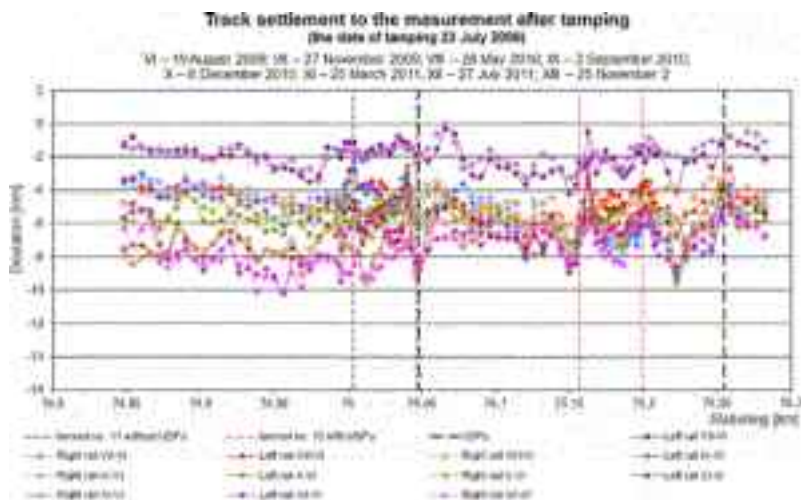

Figure 2 The track settlement after tamping (23 July 2009) to the measurement of 19 August 2009

The relative deviations of all measurements from the optimized track position are in the range of +30 mm to -27 mm. The greatest deviations are in the turnout with USPs. It is not possible

to determine the track settlement over the whole monitoring time. The track has been tamped three times during the first two years. Therefore the measurements after the last tamping were further evaluated.

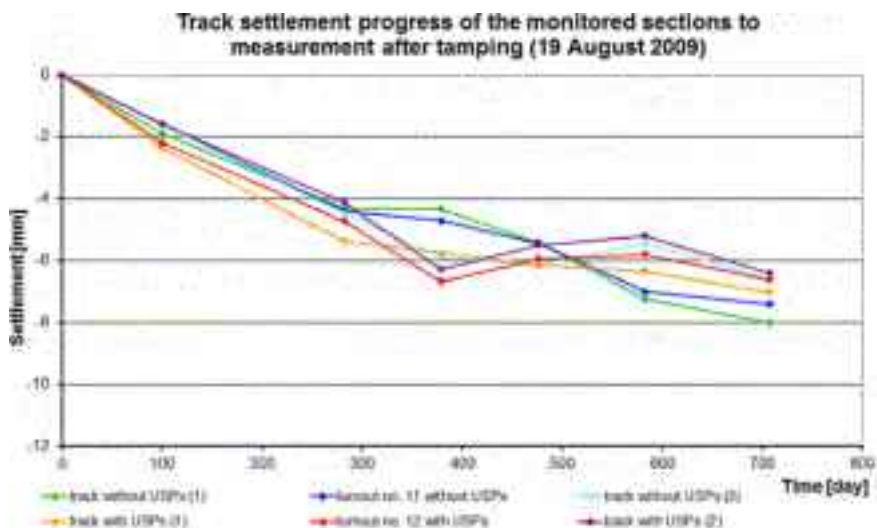

Figure 3 The track settlement progress of the monitored sections to the measurement after last tamping

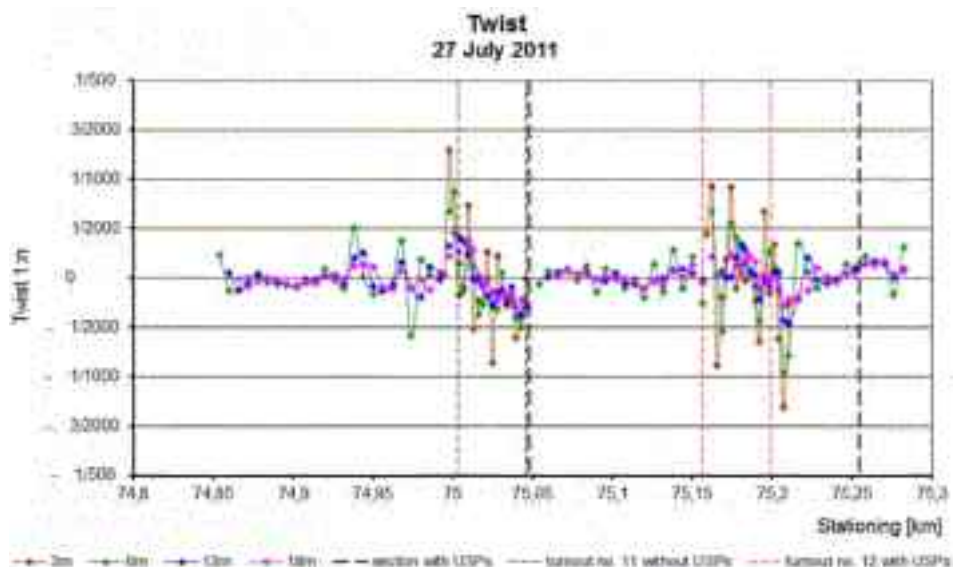

Figure 4 Track twist on the length of 3 m, 6 m, 12 m and 18 m; 27 July 2011

It is obvious that the track without USPs shows greater settlement (see Figure 2). The settlements of the section without USPs are up to 10mm (on the average 7,9 mm for the last measurement), the settlements of the section with USPs up to 9mm (on the average 6,7 mm for the last measurement). The settlement rate of the track with USPs is smaller than the settlement rate of the track without USPs in the last year (see Figure 3).

The track twist was calculated from computed cant. The distance of the measurement points is either 3m (in the turnouts) or 6m for the points out of the turnouts. Therefore, the twist was calculated for the track length of 3 m (only in turnouts), 6m, 12m and 18m. The twist for the last measurement is in Figure 4. The influence of USPs is obvious from the results, mainly for the track between turnouts.

#### 4.2 Track recording car [3]

The track recording car runs three times a year in the section. The following measuring runs were evaluated: 28 May 2008; 12 November 2008; 1 April 2009; 11 November 2009; 24 March 2010; 14 July 2010; 3 November 2010; 2 April 2011 and 4 August 2011.

Deviation of both the track alignment and longitudinal level are unequivocally smaller in the section with USPs between turnouts (see Figure 5 and Figure 6). The deviations in the turnouts are roughly the same.

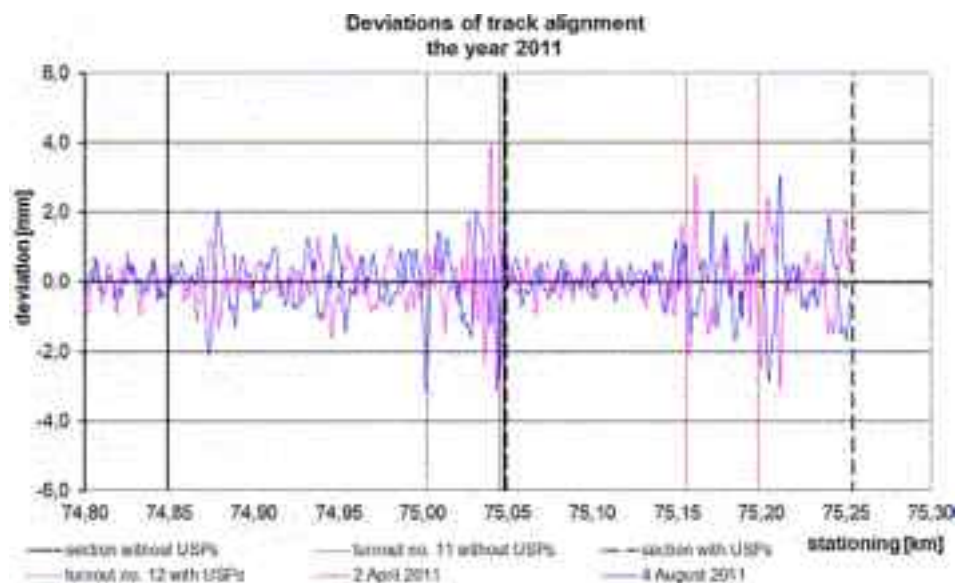

Figure 5 Deviations of track alignment in the year 2011

The track twists calculated for the track length of 3m, 6m, 12m and 18m were calculated from the measured cant. The results are the same as from precise levelling. The twists of the track with USPs are significantly smaller than the twists of the track without USPs in front of the turnout no. 11. The twists of the track in the turnout no. 12 with USPs are a little bit smaller than in the turnout no. 11 without USPs.

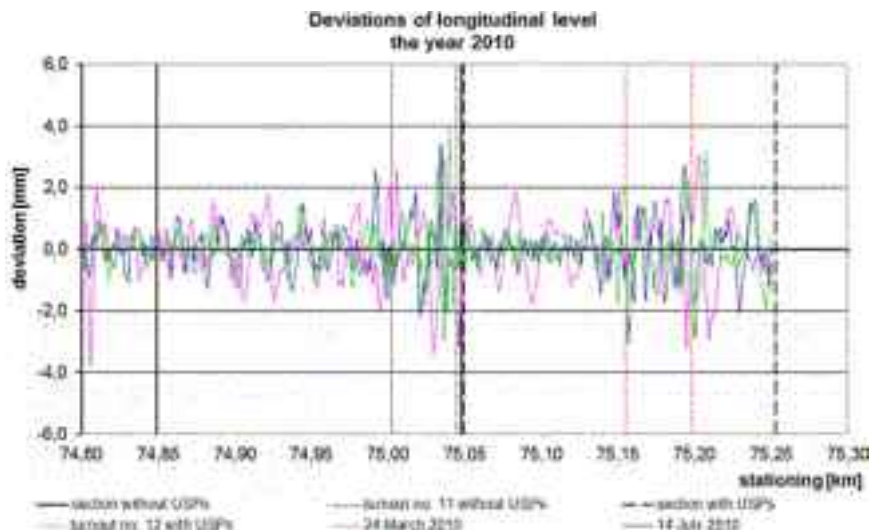

Figure 6 Deviations of longitudinal level in the year 2010

Measured data were also compared with requirements in the czech standard for maintenance limits of track parameters (ČSN 73 6360-2) – Alert Limit (AL), Intervention Limit (IL) and Immediate Action Limit (IAL).

Conclusions of the evaluations are following:

- the deviations of the parameters at the beginning of a monitoring were comparable for both sections with and without USPs, they were slightly higher in the turnout with USPs;
- the deviations in the turnouts are higher than in the other sections in general;
- the deviations of the chosen parameters don't exceed AL;
- calculated twists don't exceed AL; maximum values of twists for the both section with and without USPs are comparable;
- the deviations of track alignment, longitudinal level and twist in the section with USPs between the turnouts are lower than in the other sections from the year 2010.

## 5 Conclusion

The trial track section in the Planá nad Lužnicí railway station is focused on USP's influence on track geometry quality in a turnout evaluation. The stress of ballast bed under a sleeper is decreased by the use of USPs [4], [5]. The lifetime of ballast bed is extended. The track quality with USPs is better, track geometry deterioration is slower compared to the track quality without USPs. The positive influence of USPs is usually evident after longer time considering traffic density of a track. The higher track load the sooner evident of USP's influence and the more the investment in USPs pays off [1].

The Planá nad Lužnicí railway station is situated in the 4th czech railway corridor between Praha and České Budějovice. The traffic load of this track is from 20 000 to 40 000 gross tons per day. The trial section has been monitored since 2008. Track geometry parameters are monitored by precise leveling and track measuring car.

The data from these measuring show that the influence of USPs had started to be evident two years after USPs had been installed. The track settlement and deviations of track geometry parameters are lower in the section with USPs between the turnouts. It is expected that more time is required to evidence the influence of USPs. It is necessary to remind that the turnout with USPs was tamped three times compared to the turnout without USPs that was tamped once. The two more tamps undoubtedly influenced the track settlement.

## Acknowledgement

This outcome has been achieved with the financial support of the Ministry of Education, Youth and Sports of the Czech Republic, MS12701918 Progressive reliable and durable structures and the project of the Technology Agency of the Czech Republic no. TA01031173 Under sleeper pads.

## References

- [1] GETZNER WERKSTOFFE. Sleeper Pads Reduce Life Cycle Costs. 2010. 4 s. Dostupné z WWW: < [www.getzner.com/en/downloads/brochures/](http://www.getzner.com/en/downloads/brochures/) >.
- [2] PLÁŠEK, O.; HRUZÍKOVÁ, M. Design of Under Sleeper Pads for Turnout. In *Archiwum Instytutu Inżynierii Lądowej. Poznań : Archives of Institute of Civil Engineering*, 2007. s. 241-249. ISSN 1897-4007.
- [3] PLÁŠEK, o. a kol. Hodnocení zkušebních úseků pro pražce s pružnou ložnou plochou – 2009. Brno, 2009. s. 8, p. 3. Závěrečná zpráva. VUT v Brně, Fakulta stavební.
- [4] PLÁŠEK, O.; HRUZÍKOVÁ, M.: Použití podpražcových podložek jako ochrana kolejového lože v běžné koleji a ve výhybkách, článek v *Akustika*, ISSN 1801-9064, Studio Akustika, České Budějovice, 2007
- [5] USP – Under Sleeper Pads – Semelles sous traverses – Schwellenbesohlungen. In *Summarising report of uic Project No. 1/05/U/440* [online]. 4th Edition. Vienna, 2009 [cit. 2011-07-11]. s. 40. Dostupné z WWW: <[www.uic.org/IMG/pdf/2009-03-26\\_Summarising\\_Report\\_UIC-USP.pdf](http://www.uic.org/IMG/pdf/2009-03-26_Summarising_Report_UIC-USP.pdf)>.





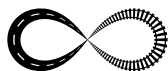

## CONTINUOUSLY WELDED RAIL (CWR) TRACK BUCKLING AND SAFETY CONCEPTS

Sanjin Albinović<sup>1</sup>, Mirna Hebib–Albinović<sup>2</sup>

*1 Faculty of Civil Engineering in Sarajevo, Bosnia and Herzegovina*

*2 JP Željeznice Federacije BiH, Bosnia and Herzegovina*

### Abstract

The continuous welded rail is now in widespread use on most railways. The main reasons for their mass deployment is in the numerous advantages over the jointed track (in technical, environmental and economic terms), as well as being one of the basic preconditions for the introduction of high speed services.

The main disadvantage of continuously welded tracks is reflected in the limited freedom of expansion and contraction of the rails due to temperature changes. As a consequence, large longitudinal forces induced in the rails lead to rail deformation and lateral and longitudinal displacements of the track. This paper will present a methodology for ensuring stability in the CWR track (leaflet UIC 720), and will make its comparison with the calculation method of the CWR track defined in the applicable regulations, on the lines in operation in Bosnia and Herzegovina.

*Keywords: continuous welded rail, track stability, UIC 720*

### 1 Introduction

Because of its many advantages, especially in terms of the working expenses and maintenance costs reduction, continuous welded rails are now widely used on most of the world's railways. However, their use requires certain precautions in the way of laying and track maintenance and dimensioning structures (elements), in order to ensure stability of the track and maintenance of rail deformations in the allowable limits.

Due to limited freedom of expansion and contraction of the rails and temperature changes, the rails can induce large longitudinal forces which can, in the middle of the fixed part, in extreme temperatures be up to 1000kN.

At extremely high summer temperatures large longitudinal pressure forces appear, which may cause lateral displacement or track buckling.

These phenomena are very adverse because they cause traffic suspensions and if not detected in time, can lead to derailment of railway vehicles, tracks and road traffic accidents with disastrous consequences.

A large number of parameters influences the stability of continuous welded rails, such as climatic characteristics of the area (minimum and maximum air temperature), characteristics of the superstructure (rails, fastening systems, thresholds and ballast) and substructure elements (subgrade, ballast bed, bridges), geometric elements with imperfections (misalignment) and vehicle characteristics and movement speed. In addition, proper installation and maintenance elements of the track superstructure and substructure play a large role.

Therefore, the construction knowledge is of great importance, knowledge to the extent to which one can go in service and construction. Not all the same. Also, there is a difference

whether the buckling of continuous welded rails comes at a temperature of 30°C or 40°C, whether continuous welded rails and curves are of smaller radius (sharper than 300 m, etc). According to the Bosnia and Herzegovina regulations on track stability calculations implemented by the method of prof. K.N.Mishchenko (from 1952.g) and German Railways (DB), that are based on theoretical considerations and experimental track testing, the quality of the current track structure noticeably differs. This paper aims to compare these methods and guidelines on the criteria of safety and stability of a CWR track (UIC -720).

## 2 Calculation of the CWR tracks stability

### 2.1 Calculation of CWR tracks stability according to the current regulations in BiH

The concept of safety, security and stability of a CWR track, according to the current regulations in BiH, ensures the application of 'Uputstvo 330 (Guidelines 330)' and 'Uputstvo 347 (Guidelines 347)', which were accepted by the former railway administration 'Zajednica Jugoslovenskih Željeznica (Community of Yugoslav Railways)'. According to the Guidelines 347 certain calculations were required before the installation of the CWR on bridges. Among other, track stability on the bridge and on the sections before and after the bridge needed to be checked, as well as the overall stress in the long rail track.

Also mentioned are the calculating methods for some influential values (in accordance with previously adopted regulations), as are the characteristics of the track structure elements (superstructure) and calculations of their allowed values.

Influential values calculation is based on a model, that should bring a solution for the CWR incorporation on bridges where all the conditions relating to the stability of the of track, the maximum size opening in the rail cracks in winter conditions, stress and rails bridge pillars must be met.

Calculations of the CWR track stability under these instructions are based on the equation of prof. K.N.Mishchenko, where stability control should be implemented for sections in front of and behind the bridge, and on the bridge itself.

The buckling process occurs mainly on a horizontal plane, and the buckling of track grid opposes its stiffness ( $I_{HK}$ ) and the lateral resistance ( $q$ ), as well as the longitudinal resistance of the track  $p$ .

The influence of the rail track longitudinal resistance on the safety factor of the track grid buckling is determined by the relationship:

$$n = 1 + \frac{P_{cr}}{4 \cdot p \cdot L_{cr}} \quad (1)$$

where  $p$  is the longitudinal resistance of the sleeper in the ballast prism of a single rail.

The initial value of critical force  $P_{cr}^{(0)}$  is determined by the formula:

$$P_{cr}^{(0)} = 1.2 \cdot 2 \cdot N \quad (2)$$

where  $N$  is the axial force (axial pressure force) that occurs as a consequence of temperature change in a single rail. The critical force which leads to track buckling is calculated by the formula:

$$P_{cr}^{(n)} = \frac{2.416}{\sqrt[4]{n}} \cdot \sqrt[4]{I_E \cdot 2 \cdot A \cdot E^2 \cdot q^2} \quad (3)$$

where  $2A$  is double the size of a cross-section rail, and  $E$  is the modulus of elasticity of rail steel. The equivalent moment of track grid inertia is calculated by the equation:

$$I_{HK} = \beta \cdot 2 \cdot I_H \quad (4)$$

where  $I_H$  is the moment of inertia of the rail around y- axis, and  $\beta$  coefficient depends on the sleeper type (for wooden  $\beta$  is 2.0, and for concrete sleepers is 2.5).

The process is iterative and is carried out until it obtains the deviation  $\Delta$  values:

$$\Delta = \frac{P_{cr}^{(n)} - P_{cr}^{(n-1)}}{P_{cr}^{(n)}} \leq 2\% \quad (5)$$

in this case the safety factor  $k$  must be:

$$k = \frac{P_{cr}^{(n)}}{2 \cdot N} > 1.2 \quad (6)$$

Characteristics of buckling waves are represented by (given) the wave length of the track buckling ' $L_{cr}$ ' and his arrow, ' $f_{cr}$ ', and are calculated according to equations:

$$L_{cr} = 19.18 \cdot \sqrt{\frac{E \cdot I_{HK}}{P_{cr}}} \quad (7)$$

$$f_{cr} = 2.88 \cdot \sqrt{\frac{n \cdot I_{HK}}{2 \cdot A}} \quad (8)$$

In the case of stability checking of the curved track, it is necessary to determine the minimum value of lateral resistance (minimum distributed load), which prevents the track buckling and provides the track stability.

The minimum required values for track lateral resistance are determined by the equation:

$$q = \frac{P_{cr}^2 \cdot \sqrt{n}}{7.18 \cdot E \cdot \sqrt{I_{HK}} \cdot 2 \cdot A} + \frac{P_{cr}}{R} \quad (9)$$

where  $R$  is the radius of curvature. Wave length of the track buckling ' $L_{cr}$ ' and his arrow, ' $f_{cr}$ ' are calculated according to equations:

$$L_{cr} = 13.92 \cdot \sqrt{\frac{E \cdot I_{HK}}{P_{cr}}} \quad (10)$$

$$f_{cr} = 4.18 \cdot \sqrt{\frac{p \cdot I_{HK}}{2 \cdot A}} \quad (11)$$

In this way with the obtained values of the lateral resistance  $q_{kr}$ , compared with the values of resistance (Table 1 – Guide 347), we can conclude if the track has provided stability and whether it is necessary to install the devices against lateral displacement of tracks.

## 2.2 Calculation of track stability with the German Railways method

This method for calculating track grid stability is applied quite often in practice and is based on formulas of Dr. Meier (1937). It is based on calculation of critical temperature values, i.e. the difference between the neutral (required) temperature and the buckling temperature. Critical temperature track increment is calculated by the equation:

$$\Delta t_{\text{crit}} = \sqrt{\frac{8.7 \cdot I_{\text{HK}} \cdot q}{\alpha^2 \cdot (2 \cdot A)^2 \cdot E \cdot f_x}} \quad (12)$$

For the curved track, the equation is:

$$\Delta t_{\text{crit}} = -\frac{8 \cdot I_{\text{HK}}}{\alpha \cdot 2A \cdot R \cdot f_x} + \sqrt{\left(\frac{8 \cdot I_{\text{HK}}}{\alpha \cdot 2A \cdot R \cdot f_x}\right)^2 + \frac{16 \cdot I_{\text{HK}} \cdot q}{\alpha^2 \cdot (2A)^2 \cdot R \cdot f_x}} \quad (13)$$

The value of force (in both rails) which results in track buckling is calculated by the equation:

$$P_0 = \alpha \cdot \Delta t_{\text{crit}} \cdot E \cdot 2A \quad (14)$$

Length of the rail buckling is calculated by the equation:

$$L = 3 \cdot \pi \cdot \sqrt{\frac{2 \cdot E \cdot I_{\text{HK}}}{P_0}} \quad (15)$$

Critical lateral displacement of rails is calculated with the formula:

$$f = 8.7 \cdot q \cdot \frac{E \cdot I_{\text{HK}}}{P_0^2} \quad (16)$$

The calculus is carried out when we enter basic information about the material (modulus of elasticity  $E$  and coefficient of thermal extension of steel rail  $\alpha$ ) and the selected type of rail (the cross-section rails  $A$ , etc) in the expressions above. The size of the initial deformation of  $f_x$ , depends on railway management rules, and is usually 2.0 or 2.5 cm. Based on an assumed lateral resistance track ( $q$ ), calculation is getting the value of the critical temperature at which the track buckling and the value of the force required for track buckling.

## 2.3 Assessment of track grid stability (safety) according to UIC 720

In March 2005 a UIC 720 leaflet UIC 720, which contains guidelines for use, installation and control of ballasted track with continuous welded rail (CWR), as well as the new safety criteria for their stability, was issued. It replaced the older leaflet on the same subject, and contains the new improved knowledge about the forces in the continuous welded rail, that have been acquired on basis of numerous tests, theoretical research, and many years of practical experience on railway management, as well as the results of work on this subject carried out by the Committee ERRI D 202.

Structure type (CWR/BUCKLE)	Curve radius	Sleeper	Wheel load (kN)	Typical level of buckling	Max. T <sub>max</sub>
High speed CWR	650	Concrete width 250	160 150 140	20, 100	67-68
Conventional CWR	650	Concrete width 125	75 100 120	150, 250	67-68
Freight line CWR	300	Concrete width 250	160 150 140	75, 150	67-68
Freight line BUCKLE	300	Wooden width 125	75 100 120	150, 250	67-68

Figure 1 Different track properties

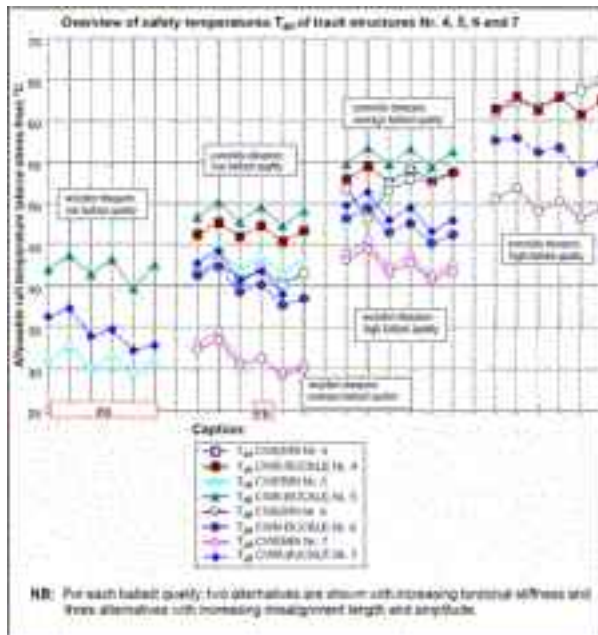

Figure 2 CWERRI and CWR-BUCKLE results for safety temperatures for secondary-line and freight-line tracks.

Safety aspects of the methodology and the introduction of the safety concept based on the buckling, as well as risk assessment represent an improvement to the previous leaflet on the same subject. The safety concept methodology is based on conducted case studies. New safety criterion is formulated based on the minimum and maximum buckling temperature ( $T_{bmax}$  and  $T_{bmin}$ ), i.e. estimating the possibility of occurrence of buckling.

As part of the case studies, numerical models were made (using CWERRI and CWR-BUCKLE programmes) for various examples of line types (high speed, major, minor, freight), concrete and wooden sleepers, and the parameters were chosen to reflect the maximum temperature for 50 % of the buckling energy levels. A variety of different scenarios (parameter values and the construction track – Figure 1) shows the allowable temperature of rails (Figure 2).

### 3 Example of the CWR stability calculations

For example, in calculation methods, for track stability, in accordance to the above mentioned regulations applicable in BiH, the same track structure (rails UIC 60, elastic fastenings, concrete sleepers) will be chosen as the one for the UIC 70 regulations example. Main railway lines in BiH, according to their characteristics (radius of curvature, speed) are in accordance with the UIC 720 class track for freight traffic (Freight line track 6 – table 1), and for speed of  $v \geq 80\text{km/h}$  and  $R_{\min} = 300\text{m}$ .

Resistance values (lateral, longitudinal), track structure or its individual elements, as well as values of maximum, minimum and neutral (required) temperatures will be adopted in accordance with applicable Guidelines 330. Input data and calculation results of stability track according to the Mishchenko and DB methods, for the curved track ( $R=300\text{m}$ ), are shown in Table 1.

**Table 1** Input data and calculation results.

Input data		Mishchenko	DB
$T_{\min} = -30^{\circ}\text{C}$	$E = 2.1 \times 10^7 \text{N/cm}$	$F_{\max}^{\text{sum}} = 789 \text{kN}$	$\Delta T_{\text{crit}} = 78,6^{\circ}\text{C}$
$T_{\max} = 65^{\circ}\text{C}$	$\alpha = 1,15 \times 10^{-6} \text{N/cm}$	$P_{\text{cr}} = 1893 \text{kN}$	$P_{\text{cr}} = 2917 \text{kN}$
$T_r = 22,5^{\circ}\text{C}$	$I_v = 513 \text{cm}^4$	$q = 117 \text{N/cm}$	
$\Delta T_s = 42,5^{\circ}\text{C}$	$I_{\text{HK}} = 2565 \text{cm}^4$	$L_{\text{cr}} = 2348 \text{cm}$	$L_{\text{cr}} = 1207 \text{cm}$

Based on the maximum and minimum temperature values ( $T_{\max}$  and  $T_{\min}$ ), that are characteristic for the BiH territory, the value of the required temperature ( $T_r = T_{\text{average}} + 5^{\circ}\text{C}$ ) is determined. Based on the temperature difference between the required and the maximum summer temperature ( $\Delta T_s$ ), according to the equation of prof. Mishchenko, certain values of maximum force in a single rail ( $F_{\max}$ ), the value of critical buckling force in both rails ( $P_{\text{cr}}$ ), the length of the critical buckling wave ( $L_{\text{cr}}$ ) and the minimum value of the lateral resistance track ( $q$ ) are calculated.

The obtained (by Mishchenko) minimum value of the lateral resistance track ( $q$ ) and the size of the lateral displacement rails ( $f_x = 2.0 \text{cm}$ ), according to the German Railways method (DB), is determined by the critical temperature at which the track buckles ( $\Delta T_{\text{crit}}$ ).

It should be noted that in these calculation methods the load of the vehicle was not taken into account. In practice, using the calculation method DB any additional stress (caused by vehicle acceleration, braking) is taken into account by using the so-called 'safety temperature' (and amounts to  $20^{\circ}\text{C}$ ), value of which reduces the value of the critical temperature. That is, when taking into account the stress, the value of safe temperatures, according to the DB method is about  $59^{\circ}\text{C}$ .

## 4 Conclusion

Based on the results of the calculations it can be concluded that there are some differences in the results obtained by different methods. The differences recommended by the UIC-720 are a little lower (up to 15%) compared to the method according to the applicable regulations in Bosnia (Mishchenko – DB) that are significant and amount to up to 50%. If we compare the results of each calculation, using all methods, we can conclude the following:

- the results of calculation done by DB method ( $T_{all}=59^{\circ}\text{C}$ ) are approximately similar to calculation results derived by the method of CWR-BUCKLE ( $T_{all}=54-58^{\circ}\text{C}$ ),
- in comparison to the calculation results gotten by CWWERi model ( $T_{all}=48-52^{\circ}\text{C}$ ), the Mishchenko method gives somewhat lower values of safe temperature ( $T_{all}=42.5^{\circ}\text{C}$ , and are still a lot lower than the CWR-Buckle model results.

These calculation results, in accordance with the Mischenko method, to ensure the stability of the track against buckling, require large values of lateral resistance track, which can in most cases provide, for the curved tracks ( $R<500\text{m}$ ), only the installation of additional devices against lateral displacement of sleepers. Also, there are considerable differences in the values of certain parameters, such as the values of the lateral resistance of the track buckling amounts that are up to  $20\text{ kN/m'}$  (according to UIC), while according to the 'Guidelines 347' maximum allowed value is  $16\text{ kN/m'}$  for the track with wooden sleepers (with devices on every sleeper). For concrete sleepers, the maximum recommended value is  $8.8$  to  $10.6\text{ kN/m'}$ , while for concrete sleepers with devices there is no recommended value.

Although, obviously, the calculation of track stability by the Mischenko method in combination with the recommended parameter values for safety, questions the justification of installing devices for resistance increment of track movement, as well as dilatation devices. From all the above, it can be concluded that it is necessary to make a detailed analysis of the existing regulations for the calculation of the stability track, or make a calculation model based on the results of a recent research (parametric analysis) carried out by the UIC and current practices for specific conditions present on the BiH railroad network.

## References

- [1] 330- Uputstvo o ugrađivanju i održavanju šina i skretnica u dugačkim trakovima, (ZJŽ 3675/68, od 05.03.1969).
- [2] 347- Uputstvo za proračun i ugrađivanju dugih trakova šina na mostovima IŽ (Sl.gl.ZJŽ 11/90 od 20.11.1990).
- [3] UIC Code 720 R - Laying and Maintenance of CWR Track, 2nd edition- March 2005.





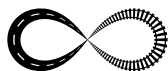

## EFFECTS OF TRAM TRACK DESIGN AND EXPLOITATION PARAMETERS ON GAUGE DIVERGENCE

Stjepan Lakušić, Maja Ahac, Ivo Haladin

*University of Zagreb, Faculty of Civil Engineering, Croatia*

### Abstract

The main objectives of the tram track design process are the rational use of urban traffic areas, while ensuring a safe and comfortable ride and long exploitation life. Generally, the guidelines for the design and maintenance of tram tracks in Zagreb, as a special group of track structures, have been developed based on engineering practices and experiences gained in the design and maintenance of railway systems. According to these guidelines, an important parameter in determining the needs for rehabilitation of tram tracks is the track gauge. The paper describes the examination of the impact of traffic volume, horizontal geometry design and incorporated elements of track superstructure on the increase in gauge divergence as decisive factor for the track reconstruction. The study is based on ten-year follow-up of changes of the tram tracks gauge. By classification and analysis of data collected by gauge measuring at more than 7 km of Zagreb tram tracks the impact of the route design and traffic volume on the process of track degradation is defined.

*Keywords: tram track, gauge measurement, horizontal geometry, superstructure, traffic volume*

### 1 Introduction

Tram network, in total length of 116 346 m, is the backbone of public transport in the Croatian's capital Zagreb – annually trams transport about 204 million passengers [1]. Individual tram lines in the city centre are exposed to traffic of 15 MGT/year, with the tram passing frequency under one minute [2]. Today, an increasing emphasis on reducing tram infrastructure management costs requires optimization of each step of operations, including track maintenance. The main objectives of track maintenance optimization are to decrease maintenance costs and increase track life length while assuring high safety standards. This can only be achieved through the creation and implementation of effective maintenance strategies.

One of the main parameters to assure safe and comfortable tram service is to maintain high quality of track geometry [3]. Track geometry – longitudinal level and horizontal curvature of both rails, track gauge, cross-level (superelevation) and track twist – represents one of the crucial track condition parameters, closely related to many other degradation phenomena, and is often used for triggering the whole range of track maintenance and renewal activities [4]. The first step in optimizing track geometry maintenance is to estimate the track degradation rate in order to properly schedule maintenance activities [5]. This requires a systematic monitoring of track geometry. The analysis of the evolution of the track geometric parameters allows to identify both the poor performance sections and the variation of the conditions of one delimited track section along the time [6].

Many attempts have been made to better understand the track geometry degradation and create empirical models for degradation mostly by the Railway Research Institutes like ERRI – European Rail Research Institute in Netherlands, TTCL in USA, RTRI in Japan, TU Graz in Austria, etc. [5]. Howe-

ver, the knowledge obtained in the field of 'big railways' can not be directly applied to the 'small tracks' in urban areas intended for public transport. Also, because of the significant differences between numerous types of urban tracks in the world, it is difficult to establish universal rules of tram track geometry degradation in service. Table 1 shows the basic differences between the 'big' and 'small' railway systems on the example of the Zagreb tram system [7, 8].

**Table 1** Characteristics of Zagreb's tram tracks

Characteristic	Zagreb's tram tracks
Location	Close proximity to the adjacent buildings, interference with the urban infrastructure.
Geometry	Track gauge = 1000mm (+3mm, -2mm), minimum horizontal curve radius = 17 m, maximum slope = 7%.
Superstructure	Grooved rail Ri-60 embedded in gravel, asphalt or precasted reinforced concrete slabs.
Vehicles	6 types of vehicles (different age, capacity, weight, wheel profile).
Traffic	Diversity of the priority and running speed.

This paper describes an attempt to define a trend of increasing tram tracks gauge, as one of the most important factors of safety and driving comfort, during exploitation. The track gauge will tend to widen through natural wear, primarily in curves. Within a short time after rail installation or re-profiling an initial phase of high abrasion that occurs as the rail head's shape conforms to passing wheel flanges is followed by more moderate wear whose growth rate depends on a number of influential factors. These influential factors of track geometry degradation can be divided to the structure factors (e.g. steel rails driving surface hardness), geometry factors (e.g. horizontal curve radius) and traffic factors (e.g. traffic volume) [6, 9, 10].

Regression analysis of track gauge divergence along the four sections of Zagreb's tram tracks, in total length of about 7 km, preformed by taking into account historical data about previously mentioned degradation factors, gave us an estimation of the track behaviour during exploitation. Preformed statistical analysis enabled the comparison of gauge values measured at different times of operation and establishment of a correlation between speed of track degradation, exploitation conditions, track geometry and incorporated elements of track structure. Described research could in future contribute to defining the general maintenance policy or improvement of decision-making process during maintenance planning on tram tracks in Zagreb.

## 2 Analysis

According to the literature, the most efficient methods to assess the track condition as a function of a number of independent variables, such as preformed maintenance, traffic volume, integrated permanent way elements and designed track geometry, are empirical or mechanistic-empirical degradation studies and macro-analysis carried out using regression techniques [6, 9]. Due to great diversity of these variables along the tram network, the question is how to, in order to better understand the behaviour of tram infrastructure during exploitation, effectively use the information on these variables. The answer to this question lies in the segmentation process, by which the linear infrastructure is divided into segments, and all abovementioned information is aggregated and associated to them [4]. Conducted research sought to determine the accuracy of estimation of track gauge divergence depending on the amount of information associated with the observed sections of the network (i.e. the level of segmentation) and whether prediction accuracy increases with increasing number of variables associated to the section's segment.

If we exclude sections with high deterioration rates, usually track geometry deteriorates linearly with tonnage or time between maintenance operations [3, 10]. However, more recent

studies revealed that the geometry deteriorates exponentially [5]. Due to these discrepancies in previous research results, analysis described in this paper was performed using linear, polynomial and exponential (power) regression over mean gauge divergence from the designed value of 1000 mm.

### 3 Overview and collection of input data

Zagreb, like many other European cities, has till this day retained the traditional, narrow-gauge tram system whose origins date back to before World War I. As a rule, desire to modernize the management process of such systems faces problems with documenting infrastructure as a precondition for its proper maintenance and development planning [11]. To carry out an overall evaluation of the track quality and identify characteristic track behaviour during exploitation it is necessary to possess comprehensive historical database about construction, maintenance and exploitation of the network [6, 12].

Historical data on the geometry and structure elements of the analyzed four sections of Zagreb's tram network were collected on the basis of supervision reports made during reconstruction of tracks 3 and 4 (completed in June 1997) and construction of tracks 1 and 2 (completed in October 2000). Initial track gauge measurements performed immediately after the track re/construction at every 1m' of track (in places of rail bearings) defined the initial, baseline condition of the track gauge before the exploitation. The gauge values needed to perform the analysis, i.e. to which reference values of the initial gauge will be compared to, were measured during spring of 2011 by means of digital track geometry measuring device GRAW DTG TET 1000. Based on the collected and measured values of gauge, the change (increase) of gauge divergence from the designed value was calculated in each measurement point of the tracks.

In regression analysis the speed of gauge degradation can be observed as a function of time and/or intensity of track exploitation [5]. The traffic volume at observed sections that passed between initial and gauge measurements conducted for this research was defined on the basis of tram timetables [7], taking into account the characteristics (weight and capacity) of different types of vehicles that operate on observed tram tracks [13]. Due to the lack of precise historical data necessary for calculating the total amount of tons transported on the observed tracks, the following assumptions concerning the transport capacity were adopted:

- vehicles operate 18 hours per day,
- on weekday amount of passenger load is 130% of the tram capacity during 6 hours and 40% during 12 hours,
- on non-working day amount of passenger load is 40% of the tram capacity during all 18 hours,
- average weight of one passenger is 70 kg.

Also, only the approximate time i.e. the pace of replacement of some older types of trams (GT6, KT4) with more modern low-floor trams (TMC 2200), which began in 2005, could be incorporated into calculation.

**Table 2** Calculated traffic volume on observed tram tracks

Gauge measurements	Tram track	Trams per week	Total number of trams	Traffic volume [mil t]
October 2000.	1	1.607	531.456	37.01
June 2011.	2	1.715	935.936	39.50
June 1997.	3	1.875	1.320.530	42.69
April 2011.	4	1.959	1.379.792	44.66

## 4 Regression analysis

### 4.1 Levels of the regression analysis (track segmentation)

Regression analysis was performed over the mean values of gauge divergence from the designed width for three levels of analysis or three degrees of track segmentation (Figure 1). Minuteness of the segmentation i.e. the number of observed types of track, depending on the number of associated information about the influential factors of gauge degradation, gradually increases from first to third level as follows.

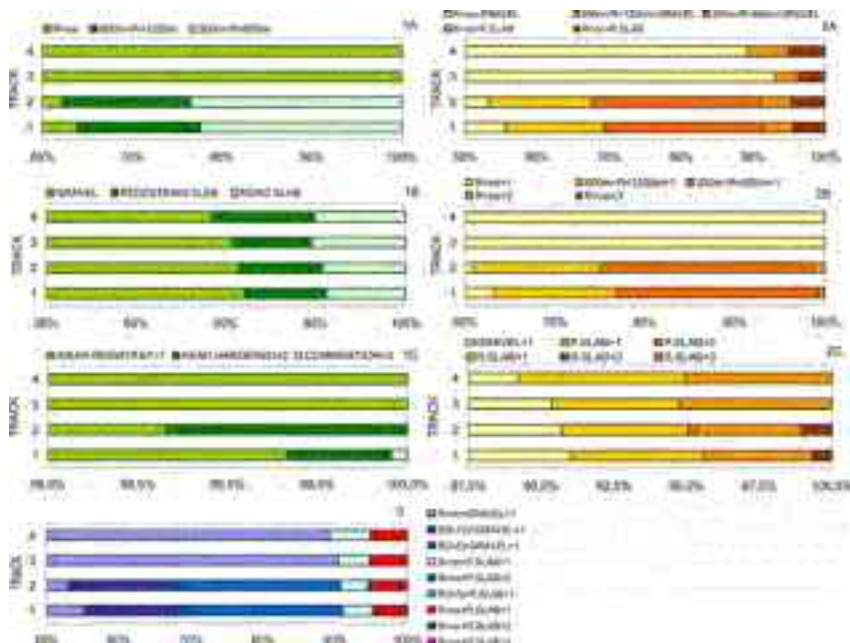

**Figure 1** The prevalence of each type of track at observed sections for different levels of segmentation

In first level of analysis tracks were divided into segments according to:

- horizontal alignment – linear segment and curve segments with radius from 600 to 1200 m, 300 to 600 m and less than 300 m (4 track types);
- rail embedding structure – tracks embedded in gravel, asphalt or precasted reinforced concrete slabs (3 track types);
- rail steel quality – wear-resistant rails, head hardened rails and their combination (3 track types).

In second level of analysis tracks were divided into segments according to possible combinations of:

- horizontal alignment and rail embedding structure (12 track types);
- horizontal alignment and rail steel quality (12 track types);
- rail embedding structure and rail steel quality (9 track types).

In third level of analysis tracks were segmented according to all possible different combinations of observed gauge deterioration influential parameters: horizontal alignment, rail embedding structure and rail steel quality. This resulted in identifying 36 possible track types on which to perform the regression analysis.

## 4.2 Regression analysis

After defining the traffic volume for each track, the track segments for each level of analysis and the mean value of gauge divergence for each track segment, regression analysis was performed. Linear, polynomial and power regression was applied to a total of 15 different segments identified at observed four tram tracks, followed by analysis of the results in the form of comparison of regression coefficients.

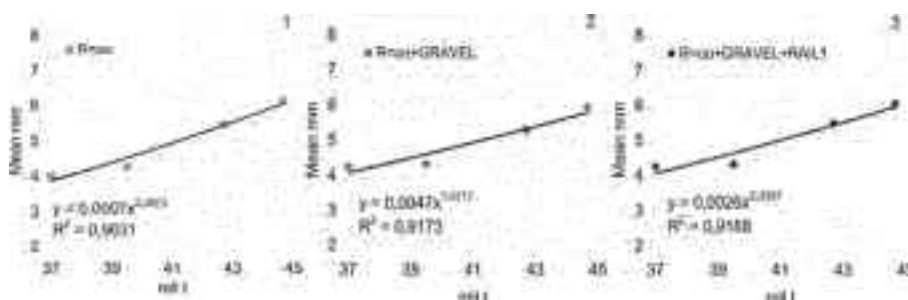

**Figure 2** Power regression charts for each level of analysis (1<sup>st</sup> – linear track segment, 2<sup>nd</sup> – linear track segment with rails embedded in gravel, 3<sup>rd</sup> – linear track segment with wear-resistant rails embedded in gravel)

## 4.3 Results of the analysis

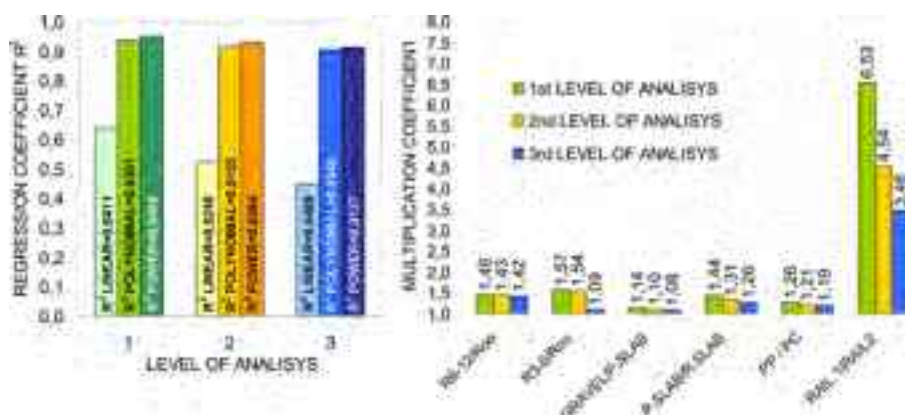

**Figure 3** Calculated average regression coefficients (left); multiplication factors for mean gauge divergence increase (right)

Figure 3 (left) shows the calculated average values of linear, polynomial and power regression coefficients. It is clear that second-degree polynomial and power function describe the change or increase in gauge divergence due to increasing (cumulative) volume of traffic considerably better than simple linear function. It can also be seen that the reliability of gauge divergence estimation slightly decreases with increasing track segmentation i.e. level of analysis.

Figure 3 (right) shows the multiplication factors for mean gauge divergence increase depending on the track type and level of analysis. As it was expected, further analysis of mean gauge divergence on different track segments showed that the increase of gauge divergence, after the same amount of cumulative traffic volume, is greater on tracks in curves, constructed

using rails of lesser quality embedded in gravel. The diagram shows that increase in level of analysis and track segmentation decreases multiplication factor for gauge divergence between different types of tracks. Also, at higher-level analysis, lower mean gauge divergence values are obtained using regression equations. From the above it can be concluded that with increasing level of segmentation we can predict the future state of the track with more precision.

## 5 Conclusions

Many foreign researches are examining the effects of track geometry degradation influential parameters on track maintenance and renewal. Adoption of best foreign practice in maintenance is more preferable than attempting to conduct wholly local studies. Nevertheless, results of most of these researches can't be directly applied because of the differences in Zagreb's tram vehicle and track characteristics which have been identified as key parameters [14]. It is therefore necessary to conduct own research to determine the applicability of foreign results in the local conditions.

The regression analysis described in this paper has shown that we can with approximately 90% confidence claim that gauge width in longitudinal sections of tracks composed of wear-resistant rails embedded in gravel will increase by 1 mm after passage of 19 mil. t of traffic volume. In case of tracks embedded in precasted reinforced concrete slabs, the same increase will occur after passage of 30 mil. t.

Results of described trend analysis must be considered with certain caution. A possible source of error is the use of different gauge measurement instruments during initial and final measurements. Another source of error are the possible positioning deviations of measurement points [15]. The accuracy of the analysis is also reduced by the adopted assumptions about the structure of tram vehicles in operation on observed tracks, and the fact that these tracks form a very small part of Zagreb's tram network (only 6% of the total network length is covered by the research). However, it can be considered that the impact of these inaccuracies is sufficiently reduced by use of mean gauge divergence values calculated for the tracks with similar characteristics

Another question that arises is the applicability of the approach described in this paper compared to the application of finite element modelling and dynamic modelling of track degradation. These models are not limited to static analyses and may be utilized to model discrete track components and determine the interaction between them, as well as the stresses; however, they are computationally expensive, they cannot be changed quickly to represent different track layouts or different loading conditions and can only present results for the specific vehicle and track under consideration.

The choice of approach should therefore be taken in light of what the results of the track geometry deterioration models are to be used for [15]. For use within maintenance decisions on a daily basis, deterministic model described in this paper, although it could hardly take into account every possible situation on the track, might be a good contribution to reducing uncertainty in predicting the track gauge deviation through time.

## References

- [1] City of Zagreb official web site, [www.zagreb.hr](http://www.zagreb.hr), 22.02.2011.
- [2] Lakušić, S. & Ahac, M.: Vibrations on Railway Tracks (Chapter), Transport Infrastructure Management, ed. S. Lakušić, Faculty of Civil Engineering at Zagreb University, Zagreb, pp. 371-416, 2009. (in Croatian language)
- [3] Esveld, C.: Modern Railway Track, Second edition, TU-Delft, 2001.
- [4] Jovanovic, S.: Railway Track Quality Assessment and Related Decision Making, IEEE International Conference on Systems, Man and Cybernetics, The Hague, 2004.
- [5] Iman Arasteh khouy: Optimization of Track Geometry Maintenance - A Study of Track Geometry Degradation to Specify Optimal Inspection Intervals, Licentiate Thesis at Luleå University of Technology, Operation and Maintenance Engineering, Luleå, 2011.
- [6] Fortunato, E., Pinelo, A., Lobo Costa, J., Gonçalves, D. & Pratas, A.: Some Results of Performance Indicators of a Railway Track Obtained During its Renewal Process, 4th International SIV Congress, Palermo, 2007.
- [7] Zagreb Municipal Transit System – ZET Ltd. official web site, [www.zet.hr](http://www.zet.hr), 13.01.2012.
- [8] Regulations for Track and Track Facilities Maintenance, Zagreb Municipal Transit System – ZET Ltd., Zagreb, 1997. (in Croatian language)
- [9] Sadeghi, J. & Askarinejad, H.: Influences of Track Structure, Geometry and Traffic Parameters on Railway Deterioration, IJÉ Transactions B: Applications, Vol.20, No.3, pp. 291-300, 2007.
- [10] Kopf, F., Maras, I., Gasser, F., Norkauer, A., Ritz, O. & Krüger, F.: Proposal for European Standard for Track Inspection and Maintenance, Deliverable 2.4, Subproject 2 of URBAN TRACK, Project funded by the European Community under the sixth framework programme priority 6 Sustainable development, global change & ecosystems, Technical University Wien, 2009.
- [11] Madejski, J.: Light Rail, Tram Track and Turnout Geometry Measurement and Diagnostic Tools, Urban Transport, Vol 77, pp. 185-195, 2005.
- [12] Andersson, M.: Strategic Planning of Track Maintenance - State of the Art, TRITA-INFRA 02-035 Report at Royal Institute of Technology, Department of Infrastructure, Division of Urban Studies, Borlänge, 2002
- [13] Tram Vehicles through Time 1891.-2006., Zagreb, 2007.
- [14] Ferreira, L. & Murray M.: Modelling Rail Track Deterioration and Maintenance: Current Practices and Future Needs'. Transport Reviews, Vol. 17, No. 3, pp. 207-221, 1997.
- [15] Lyngby, N.: Railway Track Degradation: Shape and Influencing Factors, International Journal of Performability Engineering, Vol. 5, No. 2, pp. 177-186, 2009.





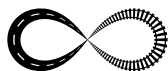

## ARC WELDING OF GROOVED RAILS – MANUAL METAL ARC WELDING VERSUS FLUX CORED ARC WELDING

Stjepan Lakušić<sup>1</sup>, Tamara Džambas<sup>1</sup>, Maja Ahac<sup>1</sup>, Ivo Haladin<sup>1</sup>, Ivan Duvnjak<sup>2</sup>

*1 University of Zagreb, Faculty of Civil Engineering,  
Department for Transportation Engineering, Croatia*

*2 University of Zagreb, Faculty of Civil Engineering,  
Department for Engineering Mechanics, Croatia*

### Abstract

Experience collected by the members of the Chair for Railways during 15 years of the supervision of re/construction of tram tracks in the Croatian capital Zagreb and city of Osijek revealed that the largest percentage of local rail damage occurs at the welded rail joints. Poorly performed and unmaintained rail welds cause increased dynamic impacts on the vehicles and the track itself that result in reduced safety and passenger comfort, faster degradation of the track and more frequent need for maintenance of both tracks and tram vehicles. Generally, production of high quality rail welds primarily depends on the applied method of welding, welder's skill and experience and the quality of welded rails steel.

The paper compares two methods of arc welding technique: classical MMAW (Manual Metal Arc Welding) method traditionally used on the Zagreb Municipal Transit System – ZET Ltd network and more up-to-date FCAW (Flux Cored Arc Welding) method which has not yet found a wider application in Croatia. A description of welding technology as well as measurement and analysis of rail surface hardness in the weld zone and rail welds tensile strength has been given. The results of the tests were supposed to answer the question whether the application of this modern welding technology, in addition to shortening the time of welding procedure, also improves the quality of the rail joints.

Comparison of results led to the conclusion that the FCAW welding method is favourable for welding standard grooved rails. It is to expect that the described testing will contribute to faster adoption of this method for welding grooved rails in ZET Ltd network. Also, conducted measurements and analysis are a good background for further research and provide useful, scientifically based conclusions applicable to the everyday engineering practice.

*Keywords: grooved rail, manual metal arc welding, Innershield weld, hardness, tensile strength*

### 1 Introduction

Constant increase in tram traffic volume and increase in vehicles speed and loads (consequence of the new modern low-floor vehicles introduction to the Zagreb's tram network) have resulted in increased stresses in track structures. Increase in stresses accelerates the track degradation i.e. track quality decrease.

Dominant factor in deciding on the renewal of rail tracks are the defects generated on the running surface of the rails during their exploitation. Various irregularities of the rail running surface in the form of corrugation, rail head wear and running surface discontinuities are the cause of the additional loads on the permanent way. Research conducted at the Dutch

Railways has shown that 75% of such defects appear on the rail joints [1]. The same problem was observed at the tracks in urban areas, especially in the case of tram tracks exposed to high traffic loads.

Years of Zagreb's tram tracks (re)construction supervision confirmed the results of this research: largest proportion of damage on rail running surface, embedding elements and fastenings occurs in track's welded sections. Presence of recesses on the rail running surface in welded sections, generated during track exploitation, causes the increase of dynamic loads for up to 215% when compared to the loads that occur on a smooth and flat running surface [2].

Since the length of the grooved tram rails is fifteen meters, by means of simple calculations it can be concluded that one kilometer of track, i.e. two kilometers of rails, consists of 134 welds or, in other words, 134 critical points whose poor execution would negatively affect the service life of track. By creating a high quality continuously welded rail tracks we could ensure greater utilization of tram lines and traffic safety, and try to minimize the need for local repair of such critical points on tracks. Such repairs require the closure of tram lines for traffic, which is particularly unfavorable in those track sections where the trams and road vehicles share the same driving surface. Also, because of the defective weld repair procedure which involves cutting, removing and replacing the damaged portion of the rail in the weld zone of a certain length, the total number of critical points on the track increases.

The production of high quality welds primarily depends on the applied method of welding, welding skills and experience and the quality of rails. Rails on Zagreb's tram tracks are welded by manual aluminothermic (AT) and metal arc welding method (MMAW). Regardless of the advantages and/or disadvantages of these welding methods, weld defects are still a major factor in the high cost of construction and maintenance of tram tracks in Zagreb. The appearance of defects in the weld areas is becoming ever more common due to increased loads and the average cost of repair or replacement of the short portion of rail at the weld area can amount to a few thousand euros. For this reason, the question of the necessity of modernization processes in the Zagreb's tram tracks construction and reconstruction arises, i.e. of the introduction of more modern rail welding methods. One such procedure is flux cored arc welding method (FCAW), never before used for welding rails in Croatia.

## 2 Flux cored arc rail welding method

FCAW is a form of manual metal arc welding method with flux filled electrode and no additional gas protection. Such welding began to be used in the 1950's – it was a new type of electrode that could be used with the application of old welding equipment for arc welding without the need for replacing the burned electrode at the end of the welding cycle.

The processes of FCAW and MMAW welding are very similar: both use the electrode with constant power supply and similar equipment, both include semi-automatic process and have a high level of production and also require three same main components: electricity, metal addition and air protection. Their main difference is in the way of protecting the electrode from the air: FCAW method uses a hollow electrode filled with flux and MMAW method uses gas for protection. Also, FCAW method is during the same conditions and same free length of the electrode more productive: MMAW method can produce an average of 2.3 to 3.6 kilograms of weld per hour and FCAW up to 25 kilograms more [3].

This paper presents a comparison of the quality and durability i.e. tensile strength and hardness of welded grooved rails R160, with welds created using both, FCAW and MMAW, welding methods.

The results of the tests were supposed to answer the question of whether with the application of modern FCAW welding technology, along with shortening the time of welding, satisfactory improvement of the quality of running surfaces rails in welded joints can be achieved.

### 3 Weld testing

For the purpose of testing four new grooved rails Ri 60 were selected by means of random sampling, two of normal steel quality (grade 700) and two made of wear resistant steel (grade 900A). By welding of rails of the same steel quality, two test samples were created:

- sample 1 – rails (steel grade 900A) welded by FCAW method;
- sample 2 – rails (steel grade 700) welded by MMAW method.

**Table 1** Mechanical properties of steel grade 700 and 900A [4, 5]

Sample	Type of rail steel		Tensile strength	Min. elongation	Approximate running surface hardness		
	Steel quality	Steel label		$R_m$ [N/mm <sup>2</sup> ]	$A_5$ [%]	[HB]	
		UIC 860V	EN 13674-1			UIC 860V	EN 13674-1
1	Wear resistant	R 900A	R 260	880–1030	10	262–304	260–300
2	Normal	R 700	R 200	680–830	14	200–245	200–240

#### 3.1 Hardness testing

Brinell hardness testing was carried out on polished rail surfaces. Polishing was carefully performed, taking into account that it does not remove the layer of steel thicker than 1 mm. Hardness measurements were then carried out, using digital measuring device Equotip 3, on the running surface of the rails in length of 100 mm to the left and right of the weld axis and on cross section of the rails.

Figure 1 shows the rail running surface hardness distribution diagram for both samples.

It can be seen from the diagram that in case of sample 1 (FCAW method) weld zone is relatively narrow – approximately 20 mm. At a distance of approximately 10 to 15 mm from the weld axis there are peaks in the hardness distribution line in the range of 208–320 HB. Hardness values on the running surface outside weld zone vary around 253 HB.

In the case of sample 2 (MMAW method) weld zone is wider – approximately 37 mm. At a distance of approximately 20 to 25 mm from the weld axis there are moderate peaks in the hardness distribution line. Hardness values on the running surface outside weld zone vary around 210 HB and are within the allowable limits shown in Table 1.

Through the analysis of the results of hardness measurements in the cross section of the rail head, web and base, average hardness values of each sample were determined (Table 2). The average deviation of the measured hardness values are within the recommended limits, except in the case of the maximum deviation of sample 1 cross section hardness, which is slightly higher than recommended.

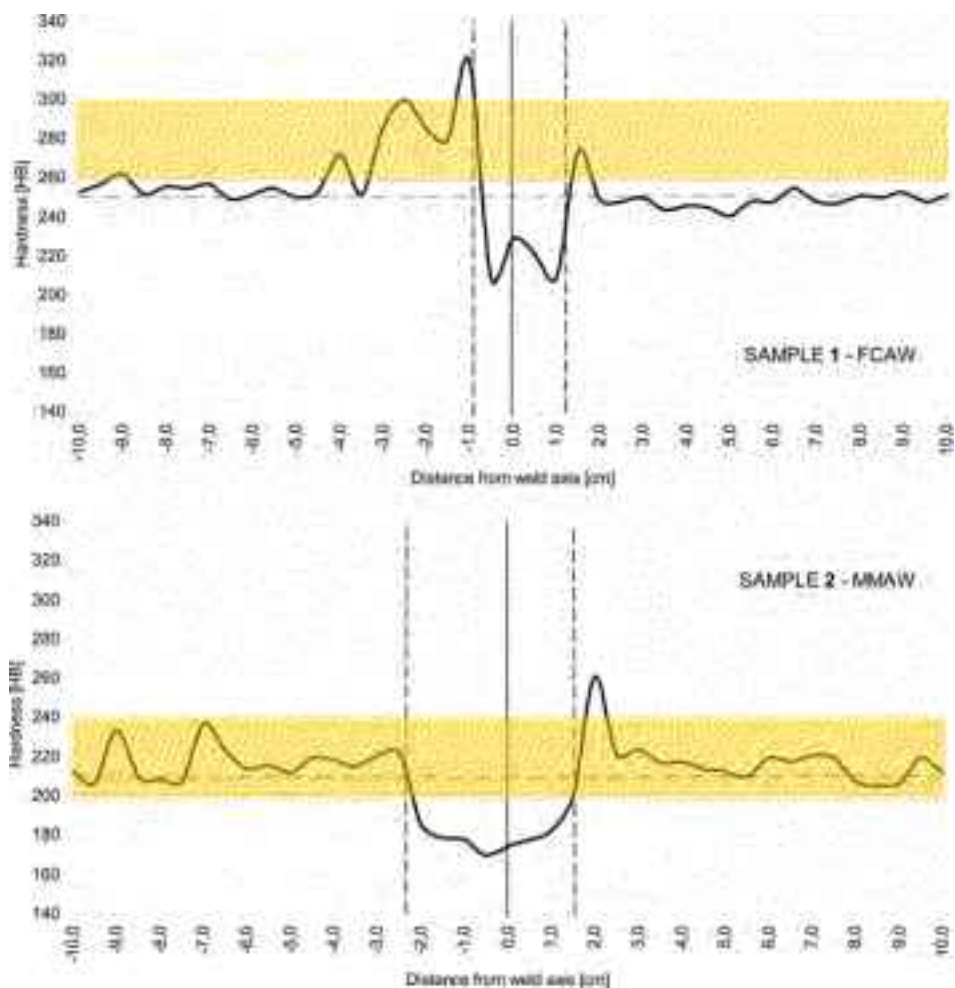

Figure 1 Rail running surface hardness distribution diagrams for both samples

Table 2 Prescribed and average measured rail cross section Brinell hardness values [HB]

Sample	A	B	C	D	E	F
1 (900A)	280	-20 / +30 (-50 / +50)	275	253	208 / 319	-45 / +66
2 (700)	220	-20 / +30 (-50 / +50)	216	210	169 / 260	-41 / +50
A	Base material hardness					
B	Permitted deviation from base material hardness					
C	Average measured rail cross section hardness					
D	Average measured rail running surface hardness					
E	Min/max measured rail running surface hardness					
F	Min/max deviation from base material hardness					

### 3.2 Tensile strength testing

Hardness testing is the easiest way to assess the quality of rail weld in the first approximation, but as a method of defining weld quality can not be used independently. Hardness testing is therefore usually a method complementary to other methods of determining weld quality, such as tensile strength testing. The tensile strength of the welded rails is tested on short proportional tubes removed by turning from the rails in four positions in their cross-section (Figure 2) [6]. Dimensions of tubes used in this investigation were designed according to HRN EN 10002-1 [7]. While cutting and turning tubes, weld defects were observed at a certain number of positions predetermined for testing. Because of that these positions were excluded from the testing. It should be noted that, as a result of more precise procedure of applying welding material, the observed defects in FCAW method tubes were considerably smaller than those in MMAW method tubes. As applicable for examination and comparison of the tensile strength of different welds, two tubes were selected from the position 3 of the sample 1 and two from the position 2 of the sample 2: tubes 13, 13\*, 22 and 22\* (the tubes in weld area are marked with asterisk). Static tensile strength testing was conducted by means of hydraulic press Zwick Roell Z600 that automatically registers applied load and tube's change in length, therefore determining the relationship of stress and strain in it. During tests it was taken into account that the increment of force in time is such that the increment of stresses produced in the tube is  $\leq 10$  N/mm<sup>2</sup> per second. As presumed, after the maximum force applied all the tubes cracked in sections of the heat affected zone of the weld, and not in the weld zone. Figure 3 shows summarized stress – strain diagram for all four specimens.

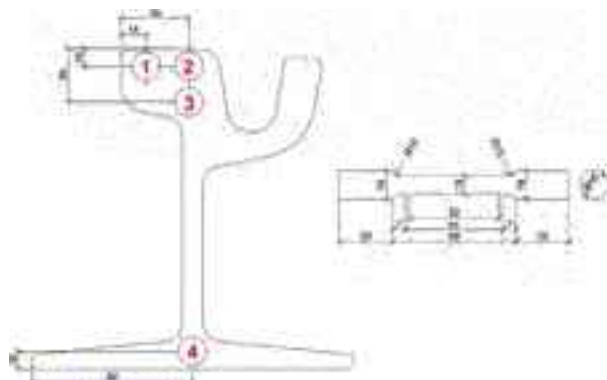

Figure 2 Dimensions of short proportional tube and tube turning points in rail cross-section

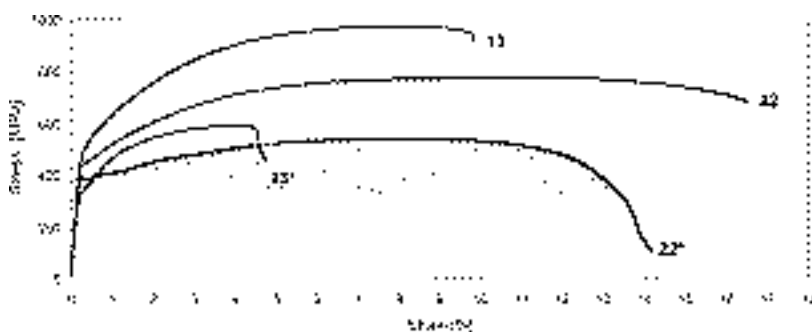

Figure 3 Summarized stress – strain diagram

**Table 3** Tensile strength test results

Tube	Max. force tensile strength	Max. force elongation	Fracture force	Fracture elongation
	$R_m$ [MPa]	$A_{gt}$ [%]		
13	973.7	8.1	921	9.8
13*	593.2	4.2	642	4.7
22	777.0	10.3	684	16.5
22*	543.2	8.2	108	14.2

Due to differences in the quality of rail steel, we couldn't directly compare tensile strength values of samples 1 and 2. Their comparison was made by subsequent calculations of the relationship between tensile strength of the tubes, with and without weld, turned out of the same sample.

In both samples the tensile strength of the tubes turned from base material of the sample is greater than the prescribed nominal tensile strength of rail steel.

Test tube 13\* on which the tensile strength of the FCAW weld was examined, has a measured tensile strength of 593.2 N/mm<sup>2</sup>. As expected, its tensile strength is lower than the tensile strength of the rail base material. The analysis of the measured values presented in table 3 revealed that the tensile strength decreased by approximately 37% due to weld.

Test tube 22\* on which the tensile strength of the MMAW weld was examined, has a measured tensile strength of 543.2 N/mm<sup>2</sup>. The tensile strength is also lower than the tensile strength of test tube made of base material. The analysis of the measured values presented in table 3 revealed that the tensile strength decreased by approximately 30% due to weld.

## 4 Discussion

In terms of hardness of the weld defined on the basis of the Brinell test is concluded that the FCAW weld more favorable due to the lower width of heat affected zone i.e. the area in which welding affects the chemical properties of rail steel thus lowering the hardness. However, it is important to note that at MMAW sample lower hardness oscillations in the weld area were observed than at FCAW sample.

Decrease in tensile strength at the weld location makes welds critical points on the track with respect to dynamic wheel impacts on rails. From this aspect MMAW method is more favorable because it has a 7% less decrease in strength than the FCAW method.

Tensile strength testing is the primary method of determining the quality of rail welds, and results obtained from tests described in this paper are relevant. Nevertheless, these results should be taken with caution because the analysis was performed on only two tubes per sample due to weld defects observed during and after test tube turning. For better comparison of the base material and weld material tensile strength, i.e. more harmonized results based on which final decision could be made, more tests should be conducted.

## 5 Conclusions

According to the literature, main advantages of FCAW over MMAW method are higher weld quality, excellent penetration and good surface appearance of the weld, greater welding speed, lower total cost per weld and increased welding productivity, high stability of the arc and shorter pre-welding preparation process.

Although the tests described in this paper showed that the FCAW method produces welds of slightly lower tensile strength, in general it could be said – with sufficient certainty – that the FCAW method is more favorable for welding of grooved rails than standard MMAW method.

It produces welds with less pronounced decrease in hardness of rail running surface and it has smaller influence on the rail steel chemical properties. This is very important from the viewpoint of increasing weld durability which is a prerequisite for increasing tram traffic safety and comfort and also reducing the cost of tram tracks maintenance.

## References

- [1] Lakušić, S.; Tkalčević, V.; Mance, G.: Welding of groove rails by Innershield welding procedure, *Welding in the world – Special Issue, Number 51, 2007*, pp. 519-526, 2007
- [2] Lakušić, S.: The dynamic effects of vehicles on the tram track, Doctoral Thesis, Faculty of Civil Engineering, Zagreb, 2003. (in Croatian)
- [3] FCAW Welding: Welding and information of different types of welding, [www.gowelding.org](http://www.gowelding.org), 28.3.2011.
- [4] UIC CODE 860/1986, Technical specification for the supply of rails
- [5] European Standard EN 13674-1:2004
- [6] Oberbau-Richtlinien und Oberbau Zusatzrichtlinien (OR, OR-Z) des vdv für Bahnen nach der BOStrab, 1997.
- [7] HRN EN 10002-1:1990; Metal materials - Tensile test - 1 Part: Test method (at room temperature), (in Croatian)





## 11 INNOVATION AND NEW TECHNOLOGY





## INNOVATIVE MATERIALS FOR SUSTAINABLE RAILWAY TRACKS – ECOTRACK

Stjepan Lakušić<sup>1</sup>, Dubravka Bjegović<sup>2</sup>, Ana Baričević<sup>3</sup>, Ivo Haladin<sup>1</sup>

*1 University of Zagreb Faculty of Civil Engineering, Dpt. of Transportation, Croatia*

*2 University of Zagreb Faculty of Civil Engineering, Dpt. of Materials, Croatia; Institut IGH, Croatia*

*3 University of Zagreb Faculty of Civil Engineering, Dpt. of Materials, Croatia*

### Abstract

In the past decade, railway infrastructure experienced significant expansion. In order to assure 'green' transportation, all across the world investments in railway infrastructure are present. Significant industrialization, and accordingly development of the transportation infrastructure caused serious atmospheric pollution and irretrievable degradation of living conditions. In order to stop this constantly raising pollution, most of current investments are focused on development of high speed railways as a way of sustainable transportation. Construction of such engineering structures requires special care during selection of applied materials due to presence of heavy dynamic loads and aggressive exposure conditions.

At the moment the market provides track systems specially designed for high speed railways, but application of inadequate materials caused insufficient durability of these structures. In order to improve existing solutions, scientists from University of Zagreb developed innovative concrete ballastless track prototype called ECOTRACK. In its nutshell, ECOTRACK is a concrete based solution that incorporates waste materials obtained during mechanical recycling of waste tyres. Incorporation of named materials assures ECOTRACK-s alignment with all relevant EU Directives in the field of waste management on one side, and on the other improvement of toughness and post-cracking behaviour desirable for the described ballastless track systems.

### 1 Introduction

The aspiration of the modern European society is to create acceptable and sustainable living conditions for the wellbeing of the whole ecosystem. The impact of the transport infrastructure on the ecosystem is considerable and in most cases negative. The development of railway infrastructure has enabled that the European land traffic be resolved favourably from the aspect of decrement of pollution caused by the burning of fossil fuels, energy disposal decrement, cheaper and faster transfer of goods and passengers as well as the economic growth. Railway traffic along with cabotage represents the main link in combined transportation in Europe. In Croatia, up until now the main focus was on just one segment of the transportation infrastructure – highways, while other means of transport were given little or no attention. It is clear, in the light of Croatia turning towards EU and sustainable development, that the segment of "green" transportation most grow stronger.

Although most of today's railways still use the classic track systems, demands for modern railways (increasing traffic capacity and the speed of modern trains, ect.) open up space for development and increasing implementation of new construction solutions such as ballastless railway tracks. In case of a ballastless railway track, the sleepers and ballast bed as the constructive elements have been replaced with other more stabile materials such as concrete or

asphalt slabs; hence in this segment of railway infrastructure an opportunity for usage of new innovative materials appeared. In the framework of the 'Concrete track systems – ECOTRACK' project, funded by the BICRO agency (Business innovation centre of Croatia), University of Zagreb Faculty of Civil Engineering developed an innovative technological solution which can significantly contribute to the strengthening of domestic manufacture of competitive and recognizable products. ECOTRACK is an eco-innovative product of a modern high speed railway structure (Figure 1) [1]. Solution is made of two-part concrete sleepers built in the concrete slab, together making a ballastless concrete track system. Although, similar solutions are already present on the market ECOTRACK incorporates by-products from mechanical recycling of waste tyres as a replacement for usual natural raw materials.



Figure 1 A conceptual prototype of the ECOTRACK railway track [1]

## 2 Methodology of the project implementation

The development of an innovative, ecologically acceptable material demands a series of tests of all the properties crucial for the material usage in a certain exposure conditions. Relevant standards for concrete railway tracks define criteria for the concrete used for the construction. The set criteria includes: compressive strength (minimum  $c\ 45/55$ ), resistance to freezing (exposure class XF3 - decrease of dynamic modulus less than 15%), capillary absorption (good quality concrete;  $< 0.6\ \text{kg/m}^2\text{v/h}$ ) and resistance to wear (exposure class XM3 – loss of material  $< 18\ \text{cm}^3/50\ \text{cm}^2$ ).

To prove the suitability of the developed material, investigation of material properties was conducted in four phases which contain the following: the selection of adequate rubber pre-treatment, selection of industrial /recycled steel fibre ratio, determination of the influence of recycled rubber on the properties of hybrid fibre reinforced concrete, choosing the optimal mix, production and testing of the prototype.

Twenty concrete mixtures with the following ratio (%) of industrial and recycled steel fibres: 100:0, 50:50 and 0:100 with or without the addition of recycled rubber (5% by total volume of the aggregate), were prepared and tested [1][2] (Mixture composition<sub>1</sub>). Used components incorporate: CEM II/BM sv 42.5 N ( $420\ \text{kg/m}^3$ ), combination of crushed and alluvial aggregate, silica fume ( $21\ \text{kg/m}^3$ ), superplasticizer (polycarboxylic ether hyperplasticiser, 0.55%<sub>m</sub>) and air entraining admixture (0.06%<sub>m</sub>) with w/c ratio equal 0.39. Industrial fibres were 35mm long with diameter of 0.55 mm and bent ends, while Croatian factory for mechanical recycling of waste tyres supplied needed amounts of recycled steel fibres (irregular shape and dimension) and rubber granulates (diameter 0.5 – 2mm).

**Table 1** Mixture composition

Mixture	Chemical admixture (kg)	Recycled rubber (kg)	Steel fibers (kg)	
			Industrial	Recycled
100I0RA	+	-	30	0
50I50RA	+	-	15	15
0I100RA	+	-	0	30
100I0RAG	+	+	30	0
50I50RAG	+	+	15	15
0I100RAG	+	+	0	30
100I0RG	-	+	30	0
50I50RG	-	+	15	15
0I100RG	-	+	0	30

For named project, more than 1000 samples were prepared in the precast concrete plant TBP Pojatno, Viadukt d.d (Figure 2). At the age of one day, specimens were transported to the laboratory of Department of Materials on Faculty of Civil Engineering University of Zagreb. The initial research of the innovative rubberized hybrid fibre reinforced concrete included a testing of 16 different properties in its fresh and hardened state. Within this paper, only a part of the results from conducted research is presented, while other results and their analysis can be found in a previous paper [2].

**Figure 2** Preparing the samples in the precast concrete plant TBP Pojatno, Viadukt d.d. [2]

### 3 The development of a conceptual prototype

During the first phase of the 'Concrete track system – ECOTRACK' project, tests on the effect of three different rubber pre-treatments on the properties of a hardened composite were done: without previous treatment, treatment with a saturated solution of sodium hydroxide and treatment with the calcium hydroxide saturated solution. Due to the presence of the zinc stearate on rubber surface, good quality bond between the rubber and cement paste is disabled [3]. By removing zinc stearate from rubber surface, the number of hydroxide groups is increased and in that way appropriate level of hydration in the interface zone is achieved [4]. Testing showed that with small rubber content ( $\leq 5\%$  of the total aggregate volume) previous rubber treatment doesn't present a crucial parameter for achieving the expected concrete properties [2]. This makes the preparation procedure of these concretes easier in industrial conditions. Ecological and economical feasibility of the recycled steel fibre implementation in concrete industry is one of the research triggers (Figure 3). By replacing a part or the whole amount of industrial steel fibres, with the recycled ones, a considerable savings of natural resources and energy can be ensured, as well as better waste management along with savings in economy.



Figure 3 a) Industrial steel fibres (Dramix RC 65/35 BN); b) Recycled steel fibres (Gumiimpex GRP)

During the second phase of the project the positive synergy between industrial and recycled steel fibre was demonstrated through increased energy absorption capacity, as well as post-cracking behaviour and resistance to impact compared to the fibre reinforced concrete with only recycled steel fibres. The fibres ability of energy absorption at different crack widths – recycled steel fibres during the development of micro cracks; industrial fibres with damage increment, macro cracks – provides the load transfer from damaged to undamaged cross section in this way ensuring improved concrete ductility [2].

Diminished ability of energy absorption of recycled fibres in comparison with industrial fibres can additionally be improved with the implementation of a small rubber content (<5% of total aggregate volume). Previous research [5–7] shows a positive synergy of the industrial steel fibres and rubber, as the rubber serves as the absorber of the produced energy without decreasing the fibre's ability to ensure the load transfer from the damaged to the undamaged cross-section. During the third phase positive synergy of hybrid fibre reinforced concrete and recycled fibres was demonstrated.

By incorporating rubber in the concrete a certain decrease of named property can be observed. However, this decrease is not substantial and still enables preparation of high strength concretes. All of the shown mixtures can be categorised in the compressive strength class C45/55 (Figure 4). Decrement of compressive strength is a consequence of a lower rubber elastic modulus. Lower elastic module values indicate a higher composite flexibility under loading, which in cases of constructions exposed to the cyclical loadings such as railway tracks, is considered as a positive material property. [2] The change of industrial and recycled steel fibre ratio has no effect on the described values.

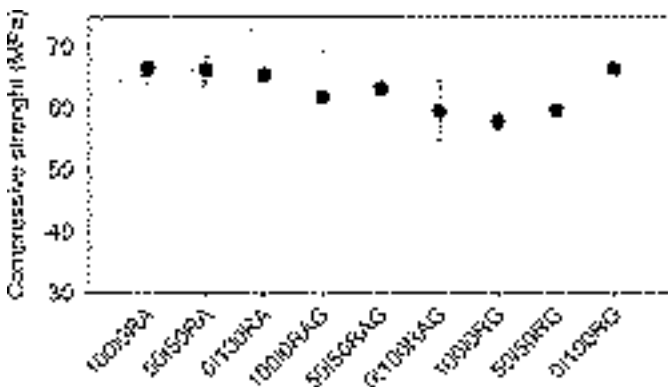

Figure 4 The effect of a chemical admixture and recycled rubber on the compressive strength of the concrete

Durability properties are of essence for reaching the proposed service life, especially in the aggressive environments in which the first Croatian high speed railway will operate. Although, different durability properties were tested within this research [2], only values prescribed with legal directives will be shown here.

By adding recycled rubber to the composite a minute improvement of concrete's resistance to wear was created, although all the prepared composites can be put in the same wear resistance class XM3. In the same way, in accordance with the values of capillary absorption, independent on the fibre ratio and presence of recycled rubber, all the prepared mixtures present the average quality concrete (Figure 5).

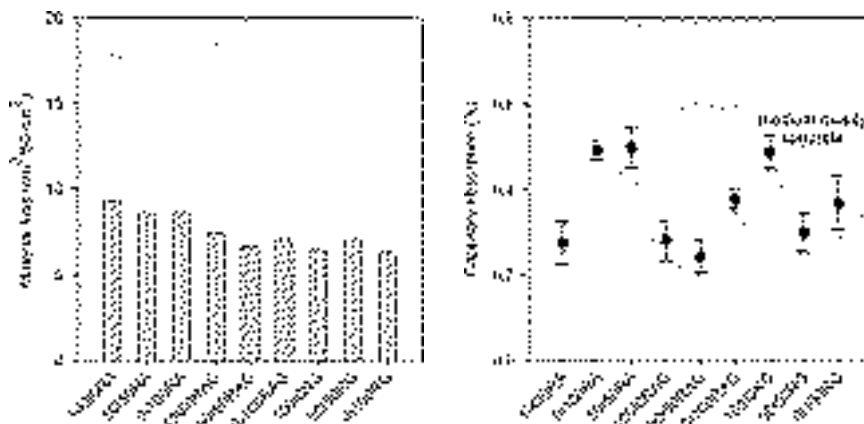

Figure 5 The effect of chemical admixture, fibre ratio change and recycled rubber on: a) resistance to wear, b) capillary absorption coefficient

According to the standards, railway track system as horizontal surface exposed to the freezing without salt is set in the exposure class XF3. In this type of environment, concrete is presumed to be resistant when the decrement of dynamic elasticity module is not higher than 15% in relation to the starting values after 56 freeze-thaw cycles (Figure 6).

The research results imply that the resistance of mixtures that contain a chemical admixture is satisfying, while the other mixtures do not satisfy the acknowledged criteria. Mixtures containing exclusively recycled rubber without chemical admixture kept the required level of resistance only by the 28<sup>th</sup> cycle, after which a more serious degradation of material occurred.

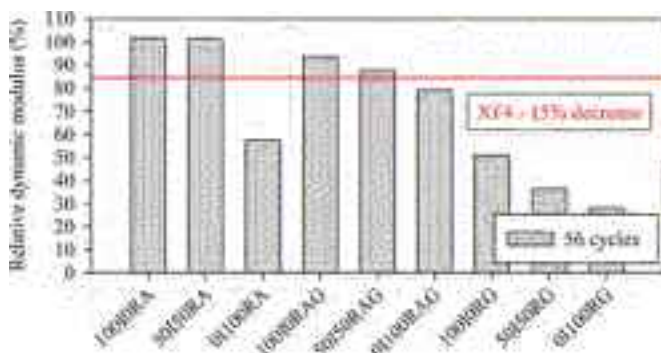

Figure 6 Resistance of concrete to freeze-thaw cycles without salt

Taking into account the prescribed criteria which concrete for construction of railway systems must fulfil, the stipulated properties were the basic parameter during the fourth phase of the project while an optimal mixture for the prototype construction was selected. The basic goal of the research is to use the maximum quantity of waste materials in order to decrease the use of non renewable resources and obtain higher sustainability of the concrete industry. However, except for the ecological parameters, the economical parameter is for sure one of the triggers



for this research. And by using recycled steel fibres instead of the industrial ones decrease of 13 to 33 % of the concrete price per  $m^3$  can be obtained. By choosing the mixture containing both industrial and recycled steel fibres, chemical admixture and recycled rubber and taking into account the length of the Zagreb-Rijeka railroad (121km), the total savings with implementation of this material could reach 1,2 million kunas only for construction of sleepers [2]. Despite series of research on the behaviour of prepared composites, final evaluation is impossible without detailed static and dynamic prototype testing. Since the prototype research demands certain resources, up until now only a research on one prototype sample has been conducted with the goal of defining basic characteristics of a referent material under the mentioned conditions [2]. A scheme of samples for the mentioned testing is shown in Figure 7.



Figure 7 A track prototype on a concrete surface – ECOTRACK [2]

## 4 Conclusion

The usage of rubberized hybrid fibre reinforced concrete elements assures an adequate resistance ability of the structure under various strain conditions. Furthermore, the appearance of first cracks on concrete surface is prolonged and thus a higher durability of such construction elements is achieved. Preliminary testing of ECOTRACK prototype, whose sleepers were prepared with RHFR, showed promising results. For the acknowledgment of the results gathered by preliminary testing, further research on a bigger number of samples is needed.

Taking into account all the advantages (Croatian production, innovation, ecological acceptability, lower price) of the ECOTRACK compared to the competitive solutions on the market, it is obvious that this product will in the future achieve a strong market up take. The results of the initial testing satisfy, and it is considered that with additional optimization of the systems components it is possible to expect, in a very brief period of time, the commercialization of the ECOTRACK. The time needed for the placement of the product on the market will depend on the disposable resources needed for the research update.

In accordance with the starting expectations, the initial testing of the ECOTRACK confirmed the possibility of the application of ecologically acceptable resources (recycling products) for the production of high performance concrete for special application. Comparing the achieved results with the criteria set up in relevant standards for concrete railway tracks, it has been confirmed that concrete with specific ratio of recycled products satisfies the mentioned conditions.

The project showed that with strong support of all included parties (science community and industry) it is possible to develop a new and innovative product, which can be produced in whole in domestic factories, providing future competitiveness of domestic companies in the field of railroad infrastructure.

## Acknowledgements

This research was performed in the scope of the projects entitled “Development of New Materials and Concrete Structure Protection Systems”, o82-o822161-2159, and “Noise and Vibration of Tram and Railway Tracks”, o82-0000000-218, funded by Croatian Ministry of Science, Education and Sports. The authors would like to extend their thanks to Viadukt dd, GUMIIMPEX-GRP dd, and Business Innovation Centre of Croatia, for their support during experimental work.

## References

- [1] I. Lakušić, S.; Bjegović, D.; Baričević, A.; Haladin, “Betoni visokih uporabnih svojstava kod kolosijeka za velike brzine,” in Međunarodni simpozijum o istraživanjima i primeni savremenih dostignuća u građevinarstvu u oblasti materijala i konstrukcija, 2011, pp. 81-88.
- [2] S. Lakušić, A. Baričević, D. Damjanović, I. Duvnjak, and I. Haladin, “Kolosijek na betonskoj podlozi - ECOTRACK,” in Građenje prometne infrastrukture, S. Lakušić, Ed. Zagreb: Građevinski fakultet Sveučilišta u Zagrebu, Zavod za prometnice, 2012, pp. 7-49.
- [3] N. Segre, P. J. M. Monteiro, and G. Sposito, “Surface characterization of recycled tire rubber to be used in cement paste matrix.,” *Journal of colloid and interface science*, vol. 248, no. 2, pp. 521-3, Apr. 2002.
- [4] L.-H. Chou, J.-R. Chang, and M.-T. Lee, “Use of waste rubber as concrete additive,” *Waste Management Resources*, vol. 25, pp. 68-76, 2007.
- [5] C. G. Papakonstantinou and M. J. Tobolski, “Use of waste tire steel beads in Portland cement concrete,” *Cement and Concrete Research*, vol. 36, no. 9, pp. 1686-1691, Sep. 2006.
- [6] A. Turatsinze, S. Bonnet, and J. Granju, “Mechanical characterisation of cement-based mortar incorporating rubber aggregates from recycled worn tyres,” *Building and Environment*, vol. 40, no. 2, pp. 221-226, Feb. 2005.
- [7] A. Turatsinze, J. Granju, and S. Bonnet, “Positive synergy between steel-fibres and rubber aggregates: Effect on the resistance of cement-based mortars to shrinkage cracking,” *Cement and Concrete Research*, vol. 36, no. 9, pp. 1692-1697, Sep. 2006.



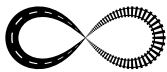

## GREEN TRACK – ENVIRONMENTAL PERFORMANCE EVALUATION FOR 'GREEN' TRAMWAY SUPERSTRUCTURE

Paul Steckler<sup>1</sup>, Brigitte Klug<sup>2</sup>, Florian Gasser<sup>3</sup>, Werner Wehr<sup>4</sup>

*1 Institute for Transportation, Vienna University of Technology, Austria*

*2 Department of Integrative Biology and Biodiversity Research,  
University of Natural Resources and Life Sciences Vienna, Austria*

*3 Fritsch, Chiari & Partner, Austria*

*4 Wiener Linien GmbH & Co KG, Austria*

### Abstract

In view of the construction of new tram lines in Vienna and due to unsatisfactory experiences with existing green track sections, Wiener Linien launched a project, funded by the Austrian Research Promotion Agency (FFG), to develop a new Viennese green track design. During conception particular attention has been paid to the ecological aspects of tram tracks in general and green tracks in particular. Therefore an environmental performance evaluation for different tram track concepts has been performed.

The special features of the new green track are slow growth, self-sufficiency and adapted turf. Draught and salt resistant flowering plants of local origin are added to commercial mixtures for dry meadows. Three different seed mixtures have been selected and are currently tested on a small section of existing green track. The development of the plants is observed for about a year before the seed mixtures are deployed on the green track sections of the new tram lines. Favouring grasses and forbs that are indigenous in Austria is one key-aspect to meet the expectations of developing an eco-friendly new green track with low maintenance demands and economic life cycle costs.

*Keywords: tram, green track, environmental benefits,  
adapted local seeds, environmental performance*

### 1 Introduction

The public is very fond of green tracks; they are believed to be optical highlights [5] and to cause little noise [1]. Some other important reasons are: reduction of sealed areas, improvement of urban climate by regulating the rain water regime, and reducing dust [7], [8]. The public often asks for more green tracks and politics (sometimes) accept this [1].

The aim of the Green Track project is to map the requirements of a modern, site specific green track and to analyse how to meet the challenges of sustainable maintenance. It follows a new approach to develop an alternative to already existing types of green track by introducing a blend of domestic plant species, which are perfectly adapted to the local environmental conditions.

## 2 Reasons for the 'Green Track' Project

### 2.1 New Tram Lines for Vienna

For the first time since May 1996 and after a number of line closures, Vienna's tram network will be expanded in 2012 and 2013. As a result tram line 26 will partly follow a new route, whilst the old route will be operated by the relaunched line 25.

The new tram line 26 will connect Strebersdorf and Hausfeldstraße via a 4.5 km extension. The new line will leave the existing line at Kagraner Platz, then cross the Ostbahn railway line and Gewerbepark Stadlau on elevated track and follow Oberfeldgasse eastwards towards the terminal stop at Hausfeldstraße. About 3.5 km will be dedicated tram track, 1 km of which will be built as green track. Operation is expected to start in October 2013.

Almost one year earlier tram line 25 will start operation between Floridsdorf and Aspern. Line 25 will leave the existing track at Josef-Baumann-Gasse, then pass Tokiostraße and Prandau-gasse before re-joining the existing line at Kagraner Platz and following it all the way to the terminal stop. A short section of track connecting Kagraner Platz and Kagran will be abandoned once this new branch connection and the extension of line 26 to Hausfeldstraße is in service.



Figure 1 Route of lines 25 and 26 in Donaustadt, Vienna

Construction of the extensions started in January 2012. In total there will be about 2 km of new green track, for which a new green track superstructure had to be developed [10].

### 2.2 Conditions on Existing Green Track Sections in Vienna

Wiener Linien, Vienna's public transport operator, has run only two green track sections for more than 20 years [4]. One of them, situated in the rather quiet and green surroundings of Lainz, is still in a good shape, the other one, alongside Vienna's most frequented road, shows very low plant cover. The unsatisfactory condition of the latter sparked the desire to develop a new green track layout with optimised vegetation.



**Figure 2** Existing green track in good (left) and unsatisfactory shape (right)

The green track at Lainz is dominated by (mostly seeded) grass species, whereas the 'ugly' green track is dominated by immigrated herbs and forbs. Above ground there are 346 grams of oven-dry plant mass per m<sup>2</sup> for 'good' green (lawn) track and 67 grams for 'ugly' green track with very sparse plant layer.

**Table 1** Relative portions of plant groups on a 'good' green track and a highly strained ('ugly') green track with respect to their origin (immigrated – possibly seeded) in Vienna

green track appearance	relative portion (%)						
	grasses		herbs/forbs		seedlings	moss	plant litter
	seeded	immigrated	seeded	immigrated			
'good'	40.4	0.3	10.5	6.8	< 0.1	1.2	40.8
'ugly'	6.2	11.0	27.7	32.0	0.0	0.1	23.0

### 2.3 Ecological Aspects of Tram Track

Ecological aspects are of rising importance in railway construction. Public tenders, however, have frequently been reluctant to implement them due to missing criteria for environmental evaluation. Therefore some environmental performance indicators for tram tracks in general and green tracks in particular will be defined in the process of developing the new 'Viennese green track layout'.

## 3 Green Track in Europe

In the past few years, green track has become a common sight in tram networks. About one in three tram networks in Europe includes green track sections, albeit to a very different extent. Rather new tram networks that were built in the past two decades tend to consist of green track to a much greater extent than tram networks that have evolved over time.

For example Barcelona's tram network, inaugurated in 2004, totals 18.7 km of green track, equalling 64.5% of the network. In France most of the tram networks recently launched feature about 20% of green track or more. In Freiburg, the "German capital of green track", the percentage of green track is more than 45%, and still rising. Of course the larger and the more urban tram networks are the higher is the demand for covered track, especially where space is restricted. Still up to 10% of green track are quite usual in some major German cities. However, in Vienna currently just about 1.5 km are green track, that is about one percent of the network [1].

Green track exists in various designs. The most common distinctive features are the kind of plants used – different species of grass, herbs and forbs or Sedum – and the vertical spacing between top of rail and vegetation, the latter usually specifying whether to use Vignol rails or grooved rails. High vegetation is characterized by a vertical spacing of just two or three centime-

tres (or less), low vegetation by a vertical spacing of about 10 centimetres or more. In between, the vegetation layer is more or less in an intermediate position.



**Figure 3** Schematic diagram of the limited space between the tram underbody and the vegetation layer, depending on the vertical spacing between top of rail and vegetation (From left to right: low vegetation, high vegetation and intermediate vegetation)



**Figure 4** Illustration of the extremely limited space between the vegetation and the underbody of Strasbourg's Eurotram (left). In Bremen the more distinctive vertical spacing between top of rail and vegetation is clearly visible and resembles low vegetation (right)

The vertical spacing between top of rail and vegetation is of special importance because it determines the maximum plant height considering that the underbody of low-floor trams is only few centimetres above the top of rail. Another distinctive feature is whether long sleepers or rail chamber filling profiles are clearly visible along the track, significantly influencing the visual beauty of the green track.

Each green track design has both advantages and disadvantages. Maintenance activities such as trimming have to be performed more often with high vegetation, but trimming with large maintenance equipment might be easier. The need for artificial irrigation depends on the climatic conditions and the plants used, the former also determining if winter service has to be considered. With high vegetation (and substrate) a shear-off by snowploughs is more likely than with other green track concepts. Emergency vehicles are allowed to run on some green tracks, though this most likely causes damages. The concept to create a green track that can – in case of emergency – also be used as a route for ambulances or other cars, is based on the idea to construct a compacted gravel bed and seed this with slow-growing gravel turf [2]; however the weight of the vehicles and the frequency of their trespassing is an automatic 'plant killer' [6]. Overall it seems that intermediate vegetation is a good compromise between the appearance of green track and cost-effective maintainability, but depending on regional and political preferences every public transport operator has to specify its own 'ideal' green track. Sometimes even safety considerations are decisive; overtopping rails could trip up inattentive pedestrians.

In Europe the majority of public transport operators favour green track with high vegetation. This is probably due to its visual advantages, as the beneficial influence of green track on shaping the cityscape is among the most frequently mentioned reasons for building green tracks.



**Figure 5** Perfect green track (left) in Mulhouse and the damaged green track at a terminal stop (right) caused by (too) long idle time and multiple mechanical impacts by trespassing passengers

Green track maintenance costs are often believed to be higher than those of conventional covered tram tracks. In fact they are very dependent on the track design and consequently also on the necessary maintenance activities. Green lawn tracks in summer-dry areas for instance – as in the Mediterranean basin or in Pannonian south-eastern Europe – need high amounts of water. Therefore these traditional green tracks can be very costly in maintenance. Consequently maintenance costs of the different green track concepts range from significantly less to double the amount of costs for covered track. In this context also the number of trams running on green track per day – usually between 100 and 200 trams, but a lot more on heavily frequented sections – and their impact on maintenance activities should not be disregarded. In the area of terminal stops green track is unsuitable wherever trams spend a lot of idle time, as plants will not grow properly without sufficient daylight.

## 4 New Viennese Green Track

### 4.1 Scope and Objectives

The aim was to create a green track that meets all the urban challenges, combining a minimum of efforts in maintenance with the best ecological performance.

Thus the objective was the adaption of the hitherto prevailing state of the art (in Vienna) – an English lawn, causing costs for frequent mowing and watering – and creating a new type of slowly growing, self-sufficient and adapted turf. More draught and salt resistant flowering plants of local origin should be added to commercial mixtures for dry meadows. Subsequently their success for the use on green tracks should be monitored.

### 4.2 Background and First Lessons Learned

#### 4.2.1 What challenges do plants meet on a track?

Physical and chemical soil characteristics (grain size, water holding capacity, compaction by trampling or vehicles, immission of heavy metals and/or salt from adjacent streets) can differ widely from site to site, but especially from natural soils. The open, mostly unshaded habitat is characterized by strong irradiation and heat; the frequently passing trams cause steady wind. This enhances the danger of draught, and it hampers the development of high flowering stems of the plants. The vehicles may also influence the pollinating insects that are necessary to guarantee on-site seed production of the flowering (dicotyledonous) plants in use. Due to the world-wide production and trade of the typical turf grasses in use, very often those species cannot cope with the local climatic conditions under stress.

So it is of crucial importance to choose indigenous seed material of regional species equipped with the following traits: slowly growing, short height of flowering stems, low water and nutrient demand as well as a reasonable shoot-root ratio. Resistance against salt and/or heavy



metals and a certain trampling resistance (for instance necessary near tram stops or at street crossings) is also advantageous.

#### 4.2.2 Winter problems

Apart from a considerable immission of salt from the streets, serious problems arise during periods with permanent snow cover. When the vegetation layer is at one level with the track, winter services can cause enormous damages in the vegetation layer; this results from the steady accumulation of dead plant material on the soil surface within some years; thus the soil surface is elevated above the track, and the snowploughs eliminate not only the snow, but also plants and some centimetres of soil from the tracks, causing permanent costs for re-seeding every spring and spoiling the visual impression of the green track.



**Figure 6** Damages by winter service: Grass sods peeled from the track and dumped alongside the track (left). View of the test field at Lainz before re-cultivation (right)

### 4.3 The Test Field at Lainz

Before the application of the new Viennese green track for the first time in Prandaugasse, the concept had to be tested. Therefore a test field was set up at the southern end of the existing green track at Lainz.

#### 4.3.1 Preparations

Previous to the installation of the test field at Lainz, phyto-sociological relevés, accompanied by micro-meteorological and pedological measurements were made at the test site. On the same tram line, but a few 100 metres outside the test site, wind speed (raised by trams passing by) and above ground plant mass were assessed. The meteorological data comprise air and soil temperature, soil moisture and radiation between 11 a.m. and 2 p.m. on a hot day in July. Soil samples from the uppermost 10 centimetres of soil were taken in autumn and spring and analyzed with regard to N, P, K,  $C_{org}$ ,  $C_{tot}$ , Ca, Mg, Na, Cl,  $SO_4$ , electrical conductivity and pH.

#### 4.3.2 Vegetation

Currently three seed mixtures are tested, one consisting of moderately draught resistant and/or salt tolerating grasses and forbs; one for very dry, sunny sections without salt immission, and one for partly shaded sections; the latter is enriched by forbs growing at forest glades and slightly shaded meadows. Almost all forb seeds for the three mixtures were hand collected, and some of the grasses as well. Except for *Cynodon dactylon*, the Bermuda grass, all grasses and forbs are indigenous in Austria.

### 4.3.3 Development on the test field

In August 2011 soil material was excavated and refilled roughly up to five centimetres under the top of rail in an area of about 100 m<sup>2</sup>. Seeding was performed by AREC Gumpenstein on 1<sup>st</sup> September 2011. Additionally to the seeding, some pre-cultivated plants of *Cynodon dactylon*, *Potentilla* spp., *Centaurea jacea*, *Prunella vulgaris*, and *Malva sylvestris* were planted one day after the seeding, their development is also monitored.

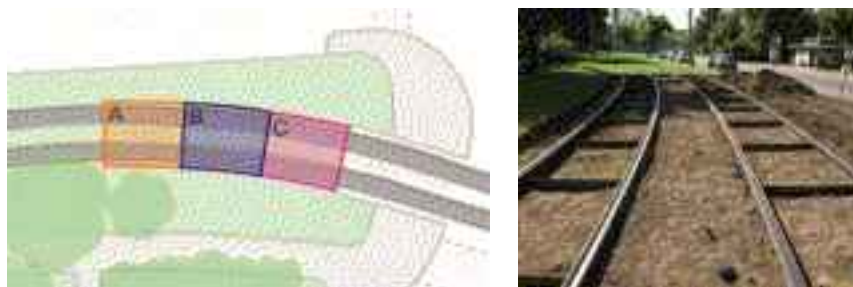

**Figure 7** View of the test field during excavation (right) and schematic diagram of the test field (left). The seed mixture for partly shaded sites is tested in sector A, the dry meadow mixture in sector B and the salt tolerant mixture in sector C



**Figure 8** The test field a few days after seeding and planting in September...



**Figure 9** ...and in late December 2011.

Due to an extremely long dry and hot period after seeding in September, regular watering was necessary for the germination phase despite the generally low water demand of the seeded plants. The development of the herbs and forbs was nevertheless satisfactory; the grass species in the dry meadow section showed an unusually long germination delay, but in November the grasses there started to germinate, too. One reason for this delay is certainly the uneven concentration of the adhesive (Soil Star 100P) that had to be used because otherwise the wind

of the passing trams would have blown away the seeds. The “glue”, a relatively new product, was very difficult to dilute and formed a hard crust in the first centimetre of topsoil. Apart from the germination delay the development on the test field is satisfactory.

#### 4.4 Future Green Track Layout

Although the green track on the test field was built with intermediate vegetation (because it would not have been possible to completely rebuild the track at the test site), the green track for lines 25 and 26 will be built with low vegetation, as requested by Wiener Linien. In particular technical criteria for both economical and fast construction at a high level of quality as well as proper and safe tram operation at low maintenance demands are decisive factors. These are for instance accessibility and replaceability of components, avoidance of leakage currents (and corrosion) and the possibility to straightforward re-establishment of the position and level of track.

### 5 Environmental Performance Evaluation

One fundamental objective of the project is the elaboration of an assessment model to evaluate the environmental impacts of tram construction projects by defining 'environmental performance indicators'. Such indicators are for example 'use of resources' or 'emissions', comprising also the technical evaluation of noise emission, and the cost comparison (life cycle costs) with other track systems. For the evaluation of the noise emission, measurements on the existing track with high vegetation and on the new track with low vegetation will be performed.

Within the project four different tram track concepts are compared: Ballasted track, conventional covered track and two green track designs (low and high vegetation) with optimized plant species composition.

**Table 2** Comparison of material requirements (illustrated as aggregated material categories) to build one kilometre of track (in absolute and relative figures). Concrete includes aggregates, mineral material summarises all kinds of ballast, gravel, sand and rock. Green track (a) is with low vegetation, green track (b) is with high vegetation.

track concept	concrete		min. material		steel		plastics		substrate		total (tons)
	t	%	t	%	t	%	t	%	t	%	
ballasted track	793	7	10805	91	288	2	9	<1	---	---	11895
covered track	7481	93	190	2	286	4	47	1	---	---	8004
green track (a)	3578	36	3466	35	370	4	14	<1	2403	25	9831
green track (b)	2071	26	2364	30	337	4	13	<1	3105	40	7890

For each of the four mentioned tram track concepts material requirements have been analysed and evaluated with regard to cumulated energy demand, green house gas emissions and recyclability.

Further evaluation analyses the life cycle costs of the different types of tram tracks. The monetary assessment of economic investments is a common practice in the private and public sector. Some decisions can lead to a short-term success, whilst long term effects are not taken into account. This harbours substantial financial risks in the future. Life Cycle Analysis offers the possibility of performing all-inclusive cost considerations for investments, revealing the costs for a life-long service of the product. Especially when comparing very different track concepts, such a life-time approach is very important, as some cost drivers are likely to appear at different ages of the tracks [9].

In the end the life cycle analysis allows to trade off the environmental benefits (illustrated by the environmental performance indicators) of green track (and the disadvantages of other track concepts) against possibly higher or lower life cycle costs, thus enabling (future) decision-makers to choose from a number of track options after estimating more than costs only.

## References

- [1] Bogel, A.: Das Grüne Gleis in Freiburg – ökologisch, leise, wirtschaftlich; Freiburger Bauweise, Oral presentation at the IASP-Symposium on Green Tracks, Berlin, 20. September 2010.
- [2] Haslgrübler, P.: Vegetationsverhalten auf Schotterrasenparkplatzflächen aus Baustoffrecyclingmaterialien, Diploma thesis, University of Natural Resources and Applied Life Sciences, Vienna, 2008.
- [3] Henze, H. J.: Einführung in den Komplex der Vegetationssysteme, Oral presentation at the IASP-Symposium on Green Tracks, Berlin, 20. September 2010.
- [4] Hochörtler, A.: Straßenbahn-Gleisbettbegrünungen in Wien und Berlin, Diploma thesis, University of Vienna, 2005.
- [5] Jahn, H. A.: Die Zukunft der Städte, Phoibos Verlag, Vienna, 2010.
- [6] Neidhart, S.: Grüne Gleise für Graz, Diploma thesis, University of Natural Resources and Applied Life Sciences, Vienna, 2010.
- [7] Schreiter, H.: Ökologische Effekte der Gleisbettnaturierung, Oral presentation at the IASP-Symposium on Green Tracks, Berlin, 20. September 2010.
- [8] Siegl, A.: Wasserverfügbarkeit und Nachhaltigkeit der Rasengleise der Dresdner Verkehrsbetriebe AG, Oral presentation at the IASP-Symposium on Green Tracks, Berlin, 20. September 2010.
- [9] Kappis, C.: Wirtschaftliche Aspekte Grüner Gleise, Oral presentation at the IASP-Symposium on Green Tracks, Berlin, 20. September 2010.
- [10] Oberhauser, A., Saghy, J., Schöft, G., Größl, M., Pichler, D., Zaussinger, J.: Neue Trassierungs- und Oberbauformen für die Wiener Straßenbahn im Praxistest, Eisenbahntechnische Rundschau (ETR) 12/2011, pp. 63-71, 2011.





## ENERGY CONSUMPTION INDUCED BY OPERATION PHASE OF RAILWAYS AND ROAD INFRASTRUCTURES

Alex Coiret<sup>1</sup>, Pierre–Olivier Vandanjon<sup>1</sup>, Romain Bosquet<sup>2</sup>, Agnès Jullien<sup>1</sup>

<sup>1</sup> LUNAM University, Ifsttar,, France.

<sup>2</sup> RFF (National Rail Network), France.

### Abstract

Up to now, transport systems have mainly been designed by considering time–efficiency, mobility and safety criteria. Today hard constraints on resources savings and environment preservation have to be taken into account at the different phases of design, maintenance and operation of these networks. This study, focused on the operation phase, aimed to provide a common framework for rail and roads energy consumption assessment. For that, the influence of infrastructure characteristics on energy consumption of vehicles was assessed, in a optimization perspective. A method for energy consumptions evaluation by exploiting contact forces models was proposed. Two models were developed, for a road and for a railway, and validated with experimental data of a vehicle on a test track and full–scale measurement of a high speed train on a given line. At last, numerical simulations are worked out with the validated models to exhibit the influence of successions of uphill and downhill on energy consumptions. These simple mechanical models pointed out the differences of the two transportation systems, in terms of developed contact forces and consumed energy.

*Keywords: energy consumption, roads, railways, vehicle model, full scale tests.*

## 1 Introduction

### 1.1 Background and objectives

Transport systems are usually designed by considering criteria of time–efficiency, mobility and safety. Up to now, many researches based on these criteria have been conducted [1, 2, 3]. Nowadays, current hard constraints on resources savings and environment preservation have to be taken into account, for design, maintenance or operation of these networks. In this study, only road and rail transport systems were considered as other transportation means handle very small fractions of traffic (air, sea, inland waters) [4]. Furthermore, attention is focused on the operation phase since rising energy costs are increasing its importance relatively to less energy–dependant costs of construction and maintenance. The overall aim was to provide a common framework for rail and roads energy consumption assessment and to determine the influence of infrastructure characteristics on vehicles energy consumption, for optimization. A method relying on contact forces models was proposed, in order to focus on the infrastructure parameters.

**1.2 International context**

Physical limits of energy resources as oil, gas and coal, added to an increasing demand for these resources lead to the development of the Peak Oil Theory that describes the unbalance between oil demand and production [5, 6]. As pointed out by Friedrich [7], it is more a question of oil production amount than oil reserves and numerous forecasts indicate peak oil occurrence at 2011 [8]. In the International Energy Agency New Policies Scenario [9], it is expected that world oil production reaches 96 million barrel/day in 2035 on the back of rising output of natural gas liquids & unconventional oil, as crude oil production plateaus. Almost half of the net growth of demand comes from China alone, mainly driven by rising use of transport fuels [10], since rapid growth of vehicles in China is accounted to raise energy demand at 734 million tons of oil equivalent by 2050 in the business as usual case, more than 5.6 times of 2007 levels. These projections reinforce the need to model the energy consumption of transport operation phase in the perspective of energy savings.

**1.3 Energy efficiency design methodology**

Technical constraints guide the conception of infrastructures as follows:

- Curvature radius, transverse slopes and speed limitations are dependant under comfort and safety relations. For example the minimum curvature radius of a high speed railway is below 5200m for a speed of 90m/s. For a car traveling at 25m/s on a road, radius of 400m and 475m are consistent with the comfort rules for respectively cross-slopes of 2.5% and 0% [3];
- Longitudinal profiles are generally limited for high speed railways at a level of 3.5‰, both by considering engine power and contact forces limitations. Road longitudinal profiles are limited at 8 to 10‰ for coping with low grip cases (ice);
- High speed railways electric supply is dependant of substations locations and – to a limited extent – of power plant locations...

Thus, railways are much less adaptable to the traveled territories, compared to roads, partly due to the weakness of contact forces, which are the counterpart of low rolling resistance. Moreover, vehicles efficiency and differences in energy sources lead to choose a common comparison criterion: the contact forces. Indeed, avoiding considering internal efficiency of vehicles, by opting for nearly arbitrary efficiency coefficient, is a mean to point out the infrastructure parameters influencing consumptions. Thus, running resistance can be expressed as the integration of power developed at the *m* contacts points of a vehicle along an itinerary, providing a simplified expression of the energy consumption *C<sub>itj</sub>* developed from the applied contact forces ( $\mu = F_x / F_z$ ;  $\tau = F_y / F_z$ ), considering the efficiency coefficient *E<sub>eff</sub>*:

$$C_{itj} = \frac{\int_{itj} F_z (\vec{\mu} + \vec{\tau})_{(M)} \cdot \vec{V}_{(M)} ds}{E_{eff}} \tag{1}$$

**2 Application to roads**

**2.1 Vehicles and road dynamical model**

The road model needed for contact forces evaluation is derived from a previous study on road safety [11], in which the influence of road properties on controllability limits of a vehicle has been experimentally approached on a test track (Fig. 1) and analyzed by a numerical model [12, 13].

Typical numerical models for safety diagnostic on itineraries (as presented in Fig 2a) are based on the application of the Newton/s second law, which, for a bicycle model, leads to equations involving forces and momentums, in the form of:

$$F_{xf} + F_{xr} = (P2m\vec{a} - P1P2\vec{P})\vec{x} \quad (2)$$

$$\begin{cases} -F_{zf} * l_f + F_{zf} * l_r + (F_{xf} + F_{xr})H = I_{yy}\ddot{\phi} \\ F_{vf} * l_f - F_{vr} * l_r = I_{zz}\ddot{\psi} \end{cases} \quad (3)$$

Where  $l_f$  and  $l_r$  are the distances between front and rear wheel to the centre of gravity,  $F_{xf}$ ,  $F_{xr}$  the front and rear components of forces on x,  $a$  the vehicle acceleration,  $m$  its mass,  $H$  its centre of gravity height,  $P1$  and  $P2$  transformation matrix,  $P$ , the weight vector,  $\ddot{\phi}$  the pitch acceleration,  $\ddot{\psi}$  the yaw acceleration and  $I_{yy}$  and  $I_{zz}$  the vehicle inertia terms.



**Figure 1** Experimental test track for models validation

A four wheel model is presented and validated (Fig. 2a and Fig. 2b) by using experimental data ( $\mu_{cons}$ ) and other models: simple point model ' $\mu_{point}$ ', two point model ' $\mu_{trans}$ ', and a commercial four wheel model ' $\mu_{Callas}$ '.

The test vehicle is a passenger car traveling at 24m/s; running a constant radius curve of 110 meters and two clothoids which are connecting the curve to the straight section (see Fig. 1). Rather good correlation is achieved by the tested models with the experimental data (Fig. 2b), especially for the constant curve part (Time period in the interval 6 to 11 seconds) and the four wheel model.

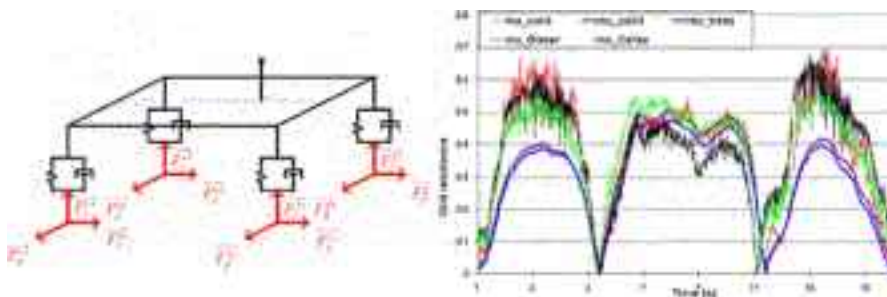
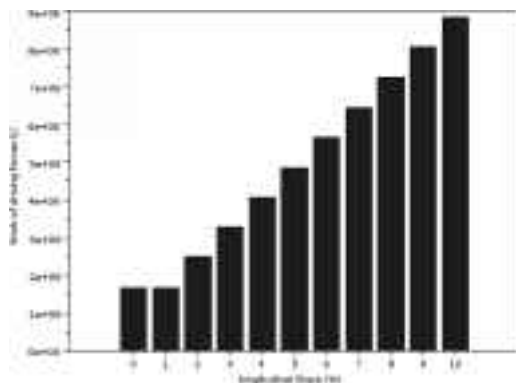

**Figure 2** four wheel model of road/vehicle interactions (left); modeled and experimented grip resistance ( $\mu_{cons}$ ) on the curved test track (right)



## 2.2 Road infrastructure parameters influence on mobilized forces

This subsection illustrates the use of a classical model dedicated to safety analysis for eco-design. It is considered that a vehicle is traveling from A to B (points); going up a slope on the first half of the travel and going down to B which is at the same height as A. Simulations are done for every percent of slope from 0% to 10%. The speed of the vehicle is maintained at 90km/h. The driving forces are computed thanks to the four wheel model. According to Eq. (1), these forces are integrated along the path to get the work, energy variations with the percentage of the slope are plotted on Fig 3.



**Figure 3** Modeling of the influence of longitudinal slopes (combined uphill & downhill sections of increasing levels from 0 to 10 %)

As illustrated in Fig. 3 the consumed energy increases with the longitudinal slope, apart for weak slope values (below 2%) when there is no need for the driver to brake on the downhill phase (rolling and aero resistances are sufficient to keep the actual speed below the desired one). Energy increasing predictions are much higher than estimated ones [3], where longitudinal slope are prone to raise energy consumption of 12% of initial level for each additional percent of slope over the 2.5% level. This relies on the fact that low internal efficiency of vehicles is shadowing the much less impacting slope influence on rolling resistance.

## 3 Application to rail infrastructures

### 3.1 Dynamical contact model

The train of  $M$  mass is considered as a point. Newton's second law gives the developed contact forces (Eq. (6)). Then the electric consumption is deduced by using a constant ratio which illustrates the efficiency of the traction system.

$$M \cdot \gamma = F - R - M \cdot g \cdot \sin(\alpha) \quad (6)$$

$\gamma$  is the longitudinal acceleration,  $F$  the total force to the drive wheels provided by the electric motor,  $\alpha$  the slope,  $R$  the resistance force which is composed of the rolling resistance (wheel to rail contact), of the frictional resistance, (viscous friction  $F_v(q)$  and dry friction  $F_s(q)$ ) and aerodynamic resistance. With  $A, B, C$  quite empirical coefficients,  $R$  is a function of the  $v$  speed [14]:

$$R = A + B \cdot V + C \cdot V^2 \quad (7)$$

### 3.2 Full scale experimental tests

In France, the Rhine–Rhône high–speed railway line forms an essential rail link between North and South of Europe. The test section is 140 km long, from Villers–les–Pots (to the East of Dijon) to Petit–Croix (to the South–East of Belfort) (Fig. 4). Collected data on this section for trial runs are used for mechanical model testing. The application of Eq. (7) to the geometry of the test section is illustrated by Fig. 4 giving the consumed power along the line (versus the kilometric point). Fig. 5 illustrates the model validity along a part of the tested track. Calculated power variations are in good agreement with measured energy on the train.



Figure 4 Map and track profile of the test section

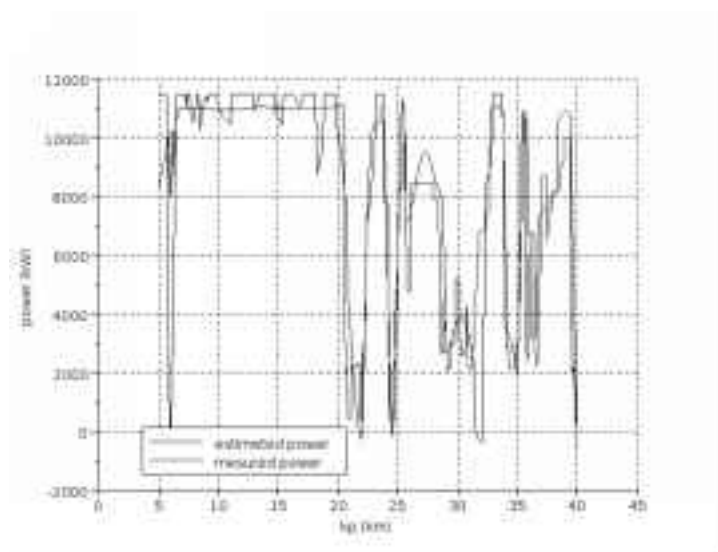

Figure 5 Modeled power versus measurements on a part of the test section

### 3.3 Energy evaluation methodology

A numerical application of the mechanical model is worked out on similar test cases that have been conducted for road evaluations. A high speed train is traveling at 320km/h between points c and d points while climbing a slope of 10 increments from 0 to 4.5 ‰ on the first half of the itinerary and down coasting to d which is at the same height as c. The speed of the train is always maintained.

As shown in Fig. 6, the energy consumption to go from c to d increases with slope. In the first case (slope 0 ‰), the consumed energy is identical between first and second section of course. Then, total consumed energy is almost constant up to a 15‰ gradient. Indeed, the train does not need to brake during the descent. This is due to the aerodynamic drag. Above this threshold, the train have to brake during the descent, that is why consumed energy increases.

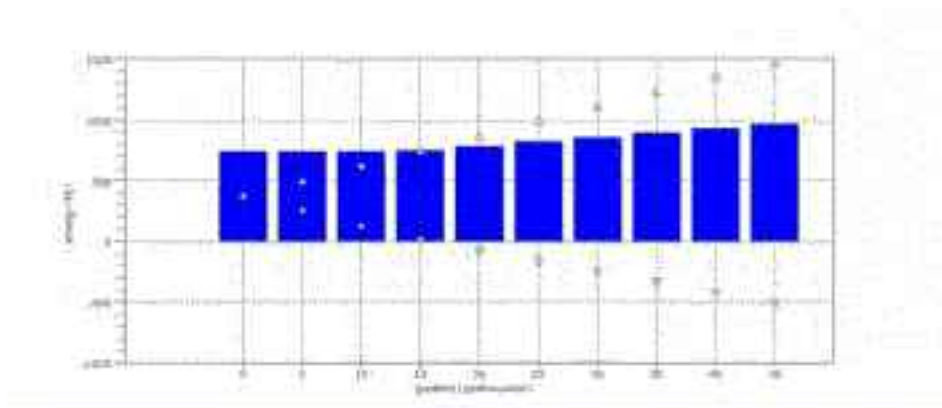

Figure 6 Modeling of the influence of longitudinal slopes (positives ( $\Delta$ ) and negatives ( $\nabla$ ) slopes) of increasing levels from 0 to 4.5 ‰)

## Conclusions

Short-term expectations on peak oil and climate change are justifying new investments of transport systems in order to improve their energetic efficiency.

This study, focused on the operation phase of road and rail infrastructures, aims to provide a common framework for energy consumption assessment. A method for energy consumptions evaluation by exploiting contact forces models has been proposed, prior to the development of two models, for road infrastructures and railways, and their validation with the help of dedicated experimental data. Numerical simulations have shown the influence of one type of elementary infrastructure characteristics on energy consumptions, via contact forces integration along itineraries. Differences between the two transportation systems are pointed out by the application of simple mechanical models for representing each one, in terms of developed contact forces and consumed energy.

These models open opportunities to investigate the influence of chosen geometry paths to the energy consumption, to evaluate energy recovery system, to optimize localizations of electric substation, and to calculate the influence of the speed references to the energy consumption. The simple models presented were limited to the fundamental equation of dynamics. The energy need for the operation phase was characterized and can be useful for network managers, aside information on infrastructure building and maintenance. The motors efficiency and energy lost by transformations before usage (inline lost for railways, transportation for oil, etc.) are still to be addressed in future work.

## References

- [1] Esposito, T., Mauro, R., Russo, F., Dell'Acqua, G.: Speed prediction models for sustainable road safety management, *Procedia Social and Behavioral Sciences* 20, 568–576, 2011.
- [2] Tingvall, C., Stigson, H., Eriksson, L., Johansson, R., Krafft, M., Lie, A.: The properties of Safety Performance Indicators in target setting, projections and safety design of the road transport system, *Accident Analysis and Prevention* 42, 372–376, 2010.
- [3] ICTAAL: Instruction sur les conditions techniques d'aménagement des autoroutes de liaison, Editions du SETRA, ISBN 2-11-091797-0, 58p, 2000.
- [4] Reddy, A.K.N., Anand, Y.P., D'Sa, A.: Energy for a sustainable road/rail transport system in India, *Energy for Sustainable Development*, Volume IV No. 1, p.29-44, 2000.
- [5] Hubbert, M.K.: Nuclear energy and the fossil fuels. Presented at the spring meeting of the American petroleum institute, San Antonio, Texas, 1956.
- [6] Gallagher, B.: Peak oil analyzed with a logistic function and idealized Hubbert curve. *Energy Policy*, 39, 790–802, 2011.
- [7] Friedrich, J., Global energy crunch: How different parts of the world would react to a peak oil scenario. *Energy Policy*, 38, 4562 – 4569, 2010.
- [8] GAO: Crude oil: Uncertainty about future oil supply makes it important to develop a strategy for addressing a peak and decline in oil production. U.S. Government Accountability Office, 2007.
- [9] IEA (International Energy Agency): World Energy Outlook 2010, <http://www.iea.org/weo/2010.asp>, 2010.
- [10] Ou, X., Zhang, X., Chang, S.: Scenario analysis on alternative fuel/vehicle for China's future road transport: Life-cycle energy demand and GHG emissions. *Energy Policy*, 38, 3943 – 3956, 2010.
- [11] Coiret, A.: Opération de recherche ' Adhérence et contrôlabilité ', Rapport final. Publications du LCPC, Route de Bouaye – CS4, 44344 Bouguenais, France, 58p., 2010
- [12] Coiret, A., Orfila, O., Kane, M.: Concept of controllability: From pavement skid resistance to safety diagnostics on roads, *RGRA* 891, 36-40, 2011.
- [13] Orfila, o. , Coiret, A., Do, M.T., Mammars S.: Modeling of dynamic vehicle–road interactions for safety-related road evaluation, *Accident Analysis and Prevention*, 42, 1736–1743, 2010.
- [14] Rochard, B.P, Schmid, F: A review of methods to measure and calculate train resistances. Proceedings of the Institution of Mechanical Engineers, Part F: Journal of Rail and Rapid Transit, 214(4) :185–199, 2000.



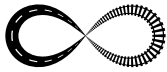

## RUCONBAR – GREENING THE MARKET OF NOISE PROTECTION SOLUTIONS

Stjepan Lakušić<sup>1</sup>, Dubravka Bjegović<sup>2</sup>, Ivo Haladin<sup>1</sup>, Ana Baričević<sup>3</sup>, Marijana Serdar<sup>3</sup>

*1 University of Zagreb Faculty of Civil Engineering, Dpt. of Transportation, Croatia*

*2 University of Zagreb Faculty of Civil Engineering, Dpt. of Materials, Croatia; Institut IGH, Croatia*

*3 University of Zagreb Faculty of Civil Engineering, Dpt. of Materials, Croatia*

### Abstract

Following the significant development of transportation infrastructure in recent years, Croatia has the need for adequate noise protection of the surrounding urban area. Construction of noise barriers is possible out of various materials such as wood, steel or concrete, but due to strict market conditions and demands for durability and static stability concrete noise barriers are most frequently used across Europe. Following this footsteps, Croatia has also increased the use of concrete noise barriers in recent years. Up to 50% of all noise protection barriers in Croatia are concrete based. Having reinforced concrete as a support structure, concrete noise barriers differ in the structure of the absorbing layer usually made out of expanded clay or wood fibres. RUCONBAR represents a new, eco-innovative concrete noise barrier solution. Innovative structure and method of obtaining the absorbing layer made out of recycled waste tyres has been developed and patented at the Faculty of Civil Engineering in Zagreb, while the whole production is feasible in Croatian production lines. RUCONBAR – rubberised concrete noise barrier is produced according to EU Directives on noise protection and waste management and incorporates the idea of using waste tyres as a raw material for further production of a new product that brings benefits in three areas: (1) noise protection, (2) environment protection through prevention of disposing recyclable materials on dump sites and (3) reduced use of natural resources.

Paper describes a development process of a new product from initial idea over test samples to real scale samples and first application. It also contains thorough analysis of environmental impact and acoustic properties compared to similar solutions as well as potential market analysis.

### 1 Introduction

Given the increased public demand for reduced traffic noise levels, there is a growing demand for better noise protection solutions out of which, highway and railway noise barriers are the most common and cost effective choice. As such, noise barriers concepts continue to strive for innovative and visually acceptable solutions, especially for urban areas. Nowadays, noise barriers are usually made out of concrete, wood or steel. Concrete barriers are usually combined with expanded clay panels within noise absorbing layer. In June 2002, EU delivered Directive 2002/49/EC [1] relating to the assessment and management of environmental noise that provide directions for noise protection. According to the EU Transportation Strategy White paper – 'European transport policy for 2010: time to decide' [2], large investments in roads construction are planned in these areas. Noise has been assessed as the one of the main environmental problems in Europe and traffic is one of the main sources of noise. The Republic of Croatia, neighbouring countries and new EU member states harmonized their regulations with the EU

Directive 2002/49/EC [1] relating to the assessment and management of environmental noise and recommendations regarding noise protection. In other words, all roads and railways that are planned for construction or rehabilitation have to include noise protection solutions. On other hand, starting from year 2006 EU Directive 1999/31/EC [3] clearly prohibits any kind of disposal of waste tyres in environment. Predictably, quantity of waste tyres available for recycling significantly increased.

The proposed solution is to develop a concept of utilisation recycled tyres as new material for reduction of urban noise pollution, called RUCONBAR. The concept provides benefits in three directions which are: (1) noise protection of urban areas by utilisation of recycled materials, (2) preventing landscape degradation from clay excavation by introducing new material and (3) environmental protection by preventing disposal of recyclable materials on landfills. In its nutshell, it is a concrete based solution composed of absorbing and bearing layer (Figure 1). By incorporating 40 % rubber granules recycled from waste tyres recovered from end-of-life vehicles, absorbing layer is innovative solution in production of noise barriers. The outcome of this concept is a product that reduces utilisation of clay with recycled rubber made out of waste tyres for noise absorbing layer. For orientation, 1 kilometre of noise protection barriers of 3 m height (3 000 m<sup>2</sup> of noise protection) uses 46.4 t of recycled rubber granules which are obtained by recycling 7 800 waste car tyres.

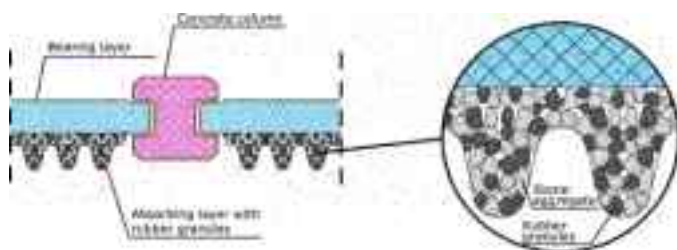

Figure 1 RUCONBAR cross section

Namely, concrete can incorporate rubber granules from recycled tyres to form a noise-absorptive layer of Rubberised Concrete Noise barriers (RUCONBAR) which has been tested, proven and patented by the Faculty of Civil Engineering, University of Zagreb by 2010.

## 2 Development of the idea

For the production of high absorptive lightweight concrete with optimised mechanical and durability properties rubber granulates were used in concrete mixture as substitution of part of the aggregate. During development phase was observed that presence of larger amount of rubber granulates (40% of aggregate volume was replaced with rubber granulates) in concrete mixture has major influence on properties of fresh and hardened concrete. In order to enhance the concrete workability and ease the placement during production, chemical admixture (superplasticizer) was added. Presence of superplasticizer helps concrete mixture to obtain needed workability during casting period. Investigated mixtures with main differences in mixture design are shown in Table 1.

Addition of rubber particles in to the concrete mixture usually causes decrease of mechanical and increase of penetrability properties compared to normal concrete. On the other hand, it was proven that addition of rubber granulates enhances concrete resistance to freezing and thawing, mechanical impact, chloride diffusion and fire, which are all important properties for materials utilised as part of the infrastructural system [5][6][7]. The rubber granulates will influence mechanical and penetrability properties depending on two major parameters: a) adhesion between the rubber and cement matrix and b) quality of the rubber granulates/cement paste interface, which is highly influenced on the presence of zinc stearate in tyre formulation [8].

**Table 1** Table 1. Investigated concrete mixtures with addition of rubber particles

Mixture	W	C	F	S	SP	RP	RP <sub>1</sub>	RP <sub>2</sub>	RP <sub>3</sub>	RP <sub>4</sub>	RP <sub>5</sub>	RP <sub>6</sub>	RP <sub>7</sub>	RP <sub>8</sub>	RP <sub>9</sub>	RP <sub>10</sub>	RP <sub>11</sub>	RP <sub>12</sub>	RP <sub>13</sub>	RP <sub>14</sub>	RP <sub>15</sub>	RP <sub>16</sub>	RP <sub>17</sub>	RP <sub>18</sub>	
Control	100	100	0	0	0	0	0	0	0	0	0	0	0	0	0	0	0	0	0	0	0	0	0	0	0
RP1	100	100	0	0	0	10	0	0	0	0	0	0	0	0	0	0	0	0	0	0	0	0	0	0	0
RP2	100	100	0	0	0	20	0	0	0	0	0	0	0	0	0	0	0	0	0	0	0	0	0	0	0
RP3	100	100	0	0	0	30	0	0	0	0	0	0	0	0	0	0	0	0	0	0	0	0	0	0	0
RP4	100	100	0	0	0	40	0	0	0	0	0	0	0	0	0	0	0	0	0	0	0	0	0	0	0
RP5	100	100	0	0	0	50	0	0	0	0	0	0	0	0	0	0	0	0	0	0	0	0	0	0	0
RP6	100	100	0	0	0	60	0	0	0	0	0	0	0	0	0	0	0	0	0	0	0	0	0	0	0
RP7	100	100	0	0	0	70	0	0	0	0	0	0	0	0	0	0	0	0	0	0	0	0	0	0	0
RP8	100	100	0	0	0	80	0	0	0	0	0	0	0	0	0	0	0	0	0	0	0	0	0	0	0
RP9	100	100	0	0	0	90	0	0	0	0	0	0	0	0	0	0	0	0	0	0	0	0	0	0	0
RP10	100	100	0	0	0	100	0	0	0	0	0	0	0	0	0	0	0	0	0	0	0	0	0	0	0
RP11	100	100	0	0	0	10	10	0	0	0	0	0	0	0	0	0	0	0	0	0	0	0	0	0	0
RP12	100	100	0	0	0	20	20	0	0	0	0	0	0	0	0	0	0	0	0	0	0	0	0	0	0
RP13	100	100	0	0	0	30	30	0	0	0	0	0	0	0	0	0	0	0	0	0	0	0	0	0	0
RP14	100	100	0	0	0	40	40	0	0	0	0	0	0	0	0	0	0	0	0	0	0	0	0	0	0
RP15	100	100	0	0	0	50	50	0	0	0	0	0	0	0	0	0	0	0	0	0	0	0	0	0	0
RP16	100	100	0	0	0	60	60	0	0	0	0	0	0	0	0	0	0	0	0	0	0	0	0	0	0
RP17	100	100	0	0	0	70	70	0	0	0	0	0	0	0	0	0	0	0	0	0	0	0	0	0	0
RP18	100	100	0	0	0	80	80	0	0	0	0	0	0	0	0	0	0	0	0	0	0	0	0	0	0

The most important property of the described noise protection barriers is the ability of noise absorption. Acoustical absorption is the property of any material that changes the acoustic energy of sound waves into another form (often heat). Due to the fact that RUCONBAR contains untested material in its absorbing layer the testing of absorbing properties has been necessary in order to determine its sound absorbing behaviour. The testing has been conducted through all the phases of material development (18 mixtures) on small laboratory samples (Figure 2) in Kundt's tube.

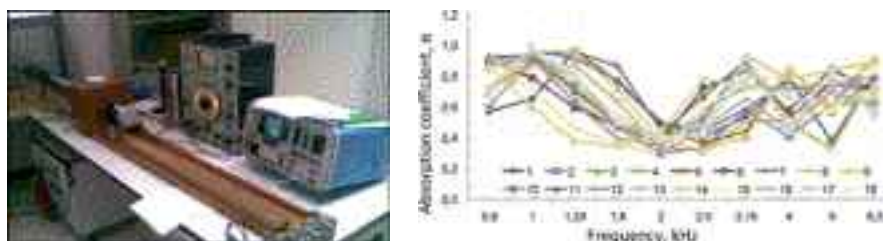
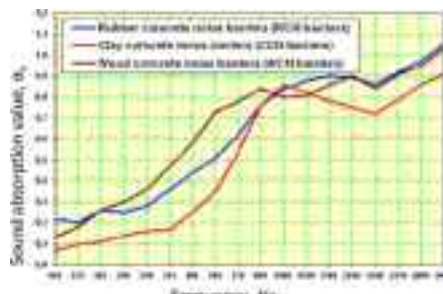

**Figure 2** Sound absorption properties of small samples

After conducting described testing on small samples, an optimal mixture has been selected to create real scale sample (10m<sup>2</sup> panels) which has been tested in a reverberation room in accordance with HRN EN ISO 354:2004 i HRN EN 1793-1:1999 standards (Figure 3).



**Figure 3** Real scale test samples in the reverberation room



**Figure 4** Comparison of sound absorption coefficient

The results of the sound absorption coefficient ( $\alpha_s$ ) testing on real scale samples are described as a function of frequency. Following symbols have been used for result description:

- $f$  – mean frequency of third of octave
- $\alpha_s$  – sound absorption coefficient
- $DL_{\alpha}$  – sound absorption value expressed as a difference of A-valued sound pressure levels.



Description of results has been given along with the results of sound absorption coefficients ( $\alpha_s$ ) of noise protection barriers with absorbing layer made of expanded clay and wood-concrete (Figure 4). According to the measurement results in accordance with the current standards, RUCONBAR noise protection barrier has been listed under A2 class of sound absorption based on the sound absorption value  $DL_{\alpha} = 6\text{dB}$ . Some of the competitive products can achieve higher classes of sound absorption, which greatly depends on the cross section of the absorption surface. The comparison of sound absorbing properties has been conducted on samples with similar absorbing surface cross sections. Conducted testing indicate satisfying absorption properties and the possibility of their improvement through further development with the goal of reaching class A3 of sound absorption.

Further research includes production of panels with different cross-section of absorption surface and its testing in reverberation room with the goal of achieving higher class of sound absorption properties. Implementation and on-site testing of RUCONBAR panels on a test section of highway is also a part of the further product development (Figure 5).

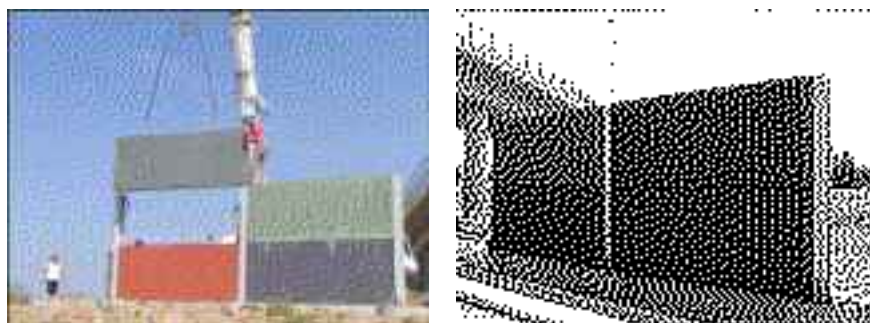

Figure 5 Installation of test section of RUCONBAR panels

### 3 Comparison of RUCONBAR with substitute solutions

Comparing the recent experiences in material usage for noise barriers (Figure 6), it can be easily concluded that concrete noise barriers have favourable market characteristics in terms of price and performance. The common absorbing layer at concrete noise barriers is expanded clay.

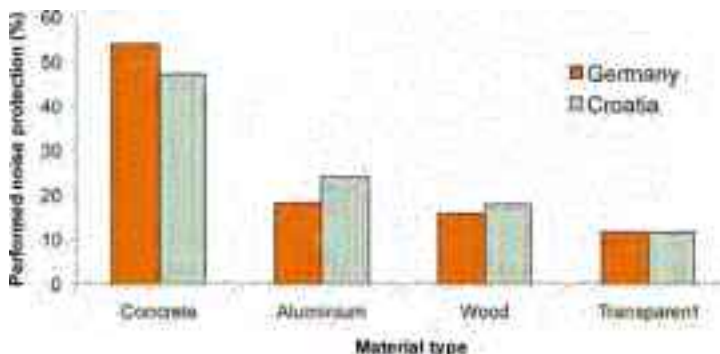

Figure 6 Materials in noise barriers products

Comparison of noise barriers can be conducted only if comparison is done within the same materials; following RUCONBAR should be compared with concrete barriers. Similar in appearance, almost equal from functionality aspect, they differ only by environmental sustainability. In accordance with South-eastern European climate, concrete barriers are often the only possible solution for reduction of noise pollution. Robustness and weight of concrete noise barriers ensures them a satisfactory static stability especially in areas with strong winds like those present in Croatia.

If RUCONBAR is compared with much light-weighted noise barriers, such as those made of wood, aluminium or Plexiglas then emphases should be made on fact that those barriers can hardly be compared with concrete barriers in terms of functionality. Use of those materials for production of barriers requires regular maintenance, which ultimately significantly raises costs and brings in question the justification of their application. Such noise barriers have commonly been used in the smaller urban centres where they fit far better in the present architecture. However, development of new concrete solutions and possibility for design show that nowadays concrete can compete on an equal basis with those solutions.

Although worldwide similar solutions incorporating recycled rubber in concrete for noise protection can be found, in Europe are present only noise barriers made from recycled rubber bounded by polyurethane and glued on concrete bearing layer. Even though it can seem that implementation of those barriers is environmentally justified, because of the large share of waste materials in absorption layer, it was demonstrated that presence of only rubber in absorption layer can be environmentally hazardous. It is widely known that tyres are extremely flammable material which can cause long-lasting fires with significant emission of greenhouse gases. So the use of those solutions can result in safety and legal issues in case of inflammation of vegetation, accidents or vandalism, due to rapid spread of flame together with dense smoke. In order to reduce rubber flammability, flame and smoke retardants are introduced into those mixtures during manufacturing process which afterwards significantly reduces recyclability of those materials. RUCONBAR is made out of 40% recycled rubber by total volume; incorporation of rubber granulates in concrete significantly reduced RUCONBAR flammability due to presence of aggregate and cement paste. Reduced flammability and better appearance present RUCONBAR as environmentally more acceptable solution.

#### **4 Market potential for new barriers**

Potential market size for uptake of RUCONBAR has been assessed upon the future investments in roads and railways in Croatia, new EU member states and neighbouring countries until 2014 and related needs for noise protection barriers. Those markets are recognised as potential beneficiaries of RUCONBAR project results, due to the amount of unmanaged waste tyres, underdeveloped transportation infrastructure or/and little efforts taken in noise prevention from traffic compared to EU15. Nevertheless, all potential market countries are in line either fully or partially with Waste Management Directive [3].

The overview of the potential market for RUCONBAR is based on the planned construction, upgrading or reconstruction of roads and railways (Table 2). The analysis is relying on publicly available data published by international and national road and railroad associations, organizations, national governments and the European Union.

**Table 2** Table 2. Planned construction/upgrading/reconstruction of roads and railways (length in km)

Country	Roads [km]	Railways [km]
Albania	124	107
Bosnia & Herzegovina	75	0
Bulgaria	546	217
Croatia	750	404
FYR Macedonia	74	313
Kosovo	89	148
Montenegro	102	192
Romania	573	488
Serbia	68	156
Slovenia	299	188
<b>TOTAL</b>	<b>2699</b>	<b>2213</b>

The reference value is 300m<sup>2</sup> of noise prevention barrier per each kilometre of highway. The potential market size of approximately 0.81 million m<sup>2</sup> for the noise barriers at highways was calculated for the region, assuming similar landscape configuration in those countries. The major projects in railways are in progress and quantities of the necessary noise protection (m<sup>2</sup>) are known. Railway traffic produces 10 dB higher noise levels than highway traffic; consequently average area of installed noise protection barriers is higher on modern railways than on highways. For every kilometre of railway approximately 900 m<sup>2</sup> of noise barriers are needed. Given the data in Table 3, the future needs of noise barriers on railways in Croatia and neighbouring countries is approximately 1.9 million m<sup>2</sup> (Figure 7).

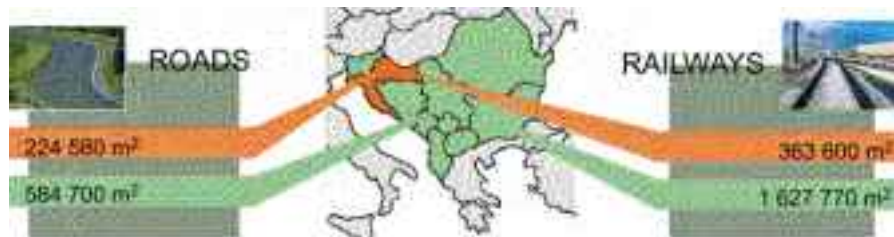

**Figure 7** Future demands for noise protection on Croatian and replication market until 2014

## 5 Ecological impact of RUCONBAR

RUCONBAR is eco innovative product with clearly defined environmental benefits and resource efficiency in a life-cycle approach: environmental performance (through significant decrease of carbon footprint and material recycling), better use of natural resources and easy visible economic sustainability. RUCONBAR reaches two major environmental problems, noise pollution and waste tyres management through ecologically and economically more efficient way – using waste to develop new product while the product itself is used for noise pollution protection. Improved environmental performance was evaluated considering entire Life Cycle of RUCONBAR comparing it with expanded clay noise barriers. Expanded clay noise barriers are most frequently applied barriers in Croatian market. Life-cycle analysis of CO<sub>2</sub>-eq savings (resources - production - placement & use - disposal/recycling) is based on available data for life cycle of RUCONBAR and of noise barriers from expanded clay (Figure 8Fi). Results indicate that RUCONBAR achieves 31 % of total CO<sub>2</sub>-eq avoidance in the respect to the expanded clay.



Figure 8 Comparison of noise barriers production process: expanded clay vs. recycled rubber

Comparing the recent experiences in waste tyre recycling of EU members with Croatian and South-eastern European countries it is obvious that these markets obtain large amounts of abandoned waste tyres. On the other hand, production of concrete noise barriers with expanded clay is limited by the amount of available clay, because required quality clay needed for production of expanded clay is available only on few excavation sites in Europe. In addition, the excavation leaves behind devastated environments whilst production of expanded clay by burning of natural clay in rotary kilns causes significant gas emissions into the atmosphere. In respect of resource efficiency, RUCONBAR project is reducing exploitation of raw material and contributing to the optimal use of natural resources. Replacing 50% volume of natural aggregate in concrete mixture by recycled waste tyres generates direct savings of 77 kg of aggregate per m<sup>2</sup> of noise barrier. Each m<sup>2</sup> of noise barrier using RUCONBAR saves 33 kg of expanded clay or 6.6 kg of natural clay. If we consider that RUCONBAR could fully replace noise barriers with expanded clay in Croatia, in three years savings in natural clay could reach 0.3 million kg only in Croatia. Additional value of RUCONBAR is that it is further reusable upon deconstruction. Innovative and environmentally friendly concept of RUCONBAR is applicable in all EU and beyond but it is most applicable in those countries that have need for waste tyres management and demand for noise protection barriers due to underdeveloped traffic infrastructure. Every year about 3.4 million tonnes of waste tyres are generated in Europe. In the EU15, only 5 % of waste tyres are uncontrollably disposed in landfills. In the 12 new EU member states and Western Balkan, averagely 29 % of waste tyres are disposed in landfills, annually. With the introduction of EU Directive in those countries, which bans landfilling of whole (July 2003) and shredded (July 2006) tyres, it is clear that there is need to increase recycling capacities and develop markets for utilising recycled tyres. RUCONBAR project provides an opportunity to accelerate transit and adoption period of these countries and reduce the gap between them and EU15 countries in the field of noise pollution and waste tyres management (Figure 9).



Figure 9 Tyre reuse percentage in EU15 and target region before and after the project

## 6 Conclusion

Innovative and environmentally friendly concept of RUCONBAR is applicable in all EU and beyond but it is most applicable in those countries that have need for waste tyres management and demand for noise protection barriers due to underdeveloped traffic infrastructure. Every year about 3.4 million tonnes [9] of waste tyres are generated in Europe. In the EU15, only 5 % of waste tyres are uncontrollably disposed in landfills. In the 12 new EU member states and Western Balkan, averagely 29 % of waste tyres are disposed in landfills, annually. With the introduction of EU Directive in those countries, which bans landfilling of whole (July 2003) and shredded (July 2006) tyres, it is clear that there is need to increase recycling capacities and develop markets for utilising recycled tyres. RUCONBAR provides an opportunity to accelerate transit and adoption period of these countries and reduce the gap between them and EU15 countries in the field of noise pollution and waste tyres management. RUCONBAR production in each country of these contributes jointly to the implementation of the Waste Management which yields significant ecological benefits in reduction of noise pollution and waste tyres disposal. Furthermore, it also contributes to economic growth and environmental performance, all conformed to Lisbon strategy.

## Acknowledgment

This research was performed in the scope of the project entitled RUCONBAR- Rubberized concrete noise barriers, under the umbrella of the Eco-Innovation initiative and Executive Agency for Competitiveness and Innovation (CIP) framework and projects funded by Croatian Ministry of Science, Education and Sports "Development of New Materials and Concrete Structure Protection Systems", o82-0822161-2159, and "Noise and Vibration of Tram and Railway Tracks", o82-0000000-218.

## Literature

- [1] "DIRECTIVE 2002/49/EC OF THE EUROPEAN PARLIAMENT AND OF THE COUNCIL of 25 June 2002 relating to the assessment and management of environmental noise," Official Journal of the European Communities, vol. L 189/12, 2002.
- [2] "European Commission's 2001 Transport White paper [COM(2006)314]."
- [3] European Commission, "Council Directive 1999/31/EC of 26 April 1996 on the landfill of waste," Official Journal of the European Communities, 1991.
- [4] Government of The Republic of Croatia, "The Regulation on management of waste tyres," Official Gazette, vol. 40/06, 2006.
- [5] D. Bjegović, A. Baričević, and M. Serdar, "Durability properties of concrete with recycled waste tyres," in 12th International Conference on Durability of Building Materials and Components, 2011, pp. 1659-1667.
- [6] D. Bjegovic, S. Lakusic, M. Serdar, and K. Opačak, "Properties of concrete made with recycled waste tires," in iNDiS 2009, 2009.
- [7] D. Bjegovic, S. Lakusic, M. Serdar, and A. Baričević, "Properties of concrete with components from waste tyre recycling," in Concrete Structures for Challenging Times, 2010, pp. 134-140.
- [8] N. Segre, P. J. M. Monteiro, and G. Sposito, "Surface Characterization of Recycled Tire Rubber to Be Used in Cement Paste Matrix," Journal of Colloid and Interface Science, vol. 248, no. 2, pp. 521-523, 2002.
- [9] ETRMA - European tyre and rubber manufacturers association, End of life tyres - A valuable resource with growing potential. 2010.

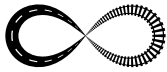

## FEM DRIVEN DESIGN PROCESS OF INNOVATIVE INTERMODAL TRUCK–RAIL SOLUTION

**Wieslaw Krason, Tadeusz Niezgodą, Krzysztof Damaziak**

*Department of Mechanics and Applied Computer Science,*

*Faculty of Mechanical Engineering, Military University of Technology, Poland*

### Abstract

A few years ago, the constructors from the Department of Mechanics and Applied Computer Science of the Military University of Technology in Warsaw began to work on the concept of an innovative wagon for truck transportation. The main design goal was to develop a solution which would allow easy load/unload procedure without extensive railway infrastructure changes. The concept of the solution took a form of a special wagon with the moving (rotating) central part. In short, the rotating part acts as a kind of a bridge allowing a truck to move through it during load/unload. During railway operation, this rotating 'bridge' is to become an integrated part of the wagon. Since the design team aimed at very challenging demands of DB1 envelope and usage of standard bogies, the layout of the wagon had to be carefully examined in terms of its overall stiffness. A unique concept of the wagon structure forced a design approach which was rather unusual for the rail industry. Instead of analyzing the almost finally developed, validated in terms of technology, structure (usual approach), numerical simulations had to be included as an immanent part of the design process. Every major design change had to be simulated in order to accurately predict its influence on the whole wagon structure. It should be stressed out that such an approach (mainly multibody [1, 2] and FE analysis [3]), although time consuming, was the only way to access information how design changes would affect wagon's mechanics. Without this knowledge design of the new wagon would not have been possible.

*Keywords: innovative railway wagon for truck transportation, structure modifications, FE analysis in design process*

### 1 Introduction

A special wagon, presented in the paper, can be used for railway transport of semitrailers and TIR type vehicles. It enables transport of vehicles of 36 tons mass and height of 4m on the GB1 clearance height. Such a wagon is equipped with a frame–support with marginal parts mounted on standard biaxial bogies and the central part lowered in respect to the marginal parts along declining walls, a rotating loading platform mounted vertically over the central part of the frame–support. Such a structure can be used for transporting various types of vehicles, for example, tractors, trucks, trailers, semitrailers, cargo containers. The railway wagon allows quick and convenient loading and unloading of vehicles and containers (no cranes needed), self loading and unloading; no platform infrastructure is required, instead of hardened, flat, surface; no need for hubs, terminals or special logistics; each wagon can be operated separately.

The model of a railway wagon for truck transport on the scale 1:14 was developed in the Laboratory of Materials Strength of the Department of Mechanics and Applied Computer Science,

Military University of Technology [4]. The model mapped essential components of the wagon and infrastructure of the loading–unloading railway platform. There was applied pneumatic supply, steering and actuators in the mechanism of rotation of the moving platform of the wagon body as well as for stiffening the construction with the use of additional supports of the wagon bottom and locking the pin joint type locks between the over–bogie part of the wagon and the tailboards of the body platform. Figure 1 demonstrates the photos illustrating constructing and basic functions of the model of the railway wagon for transport of trucks on the scale 1:14.

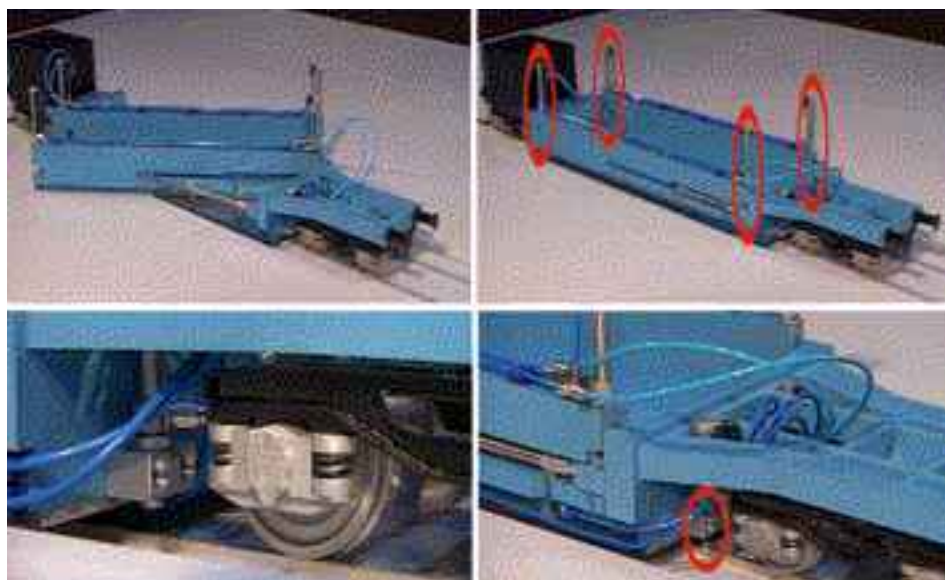

**Figure 1** Model of the special wagon for railway transport of semitrailers developed in Military University of Technology – model with the main wagon assemblies on the scale 1:14 [4].

The discussed model enables demonstration of the principle of operations and visualization of basic functions of the railway wagon for transport of trucks – Figure 2. The model served also to prepare kinematic simulations of the real cooperation of wagon subsystems with the rotatable platform of the body.

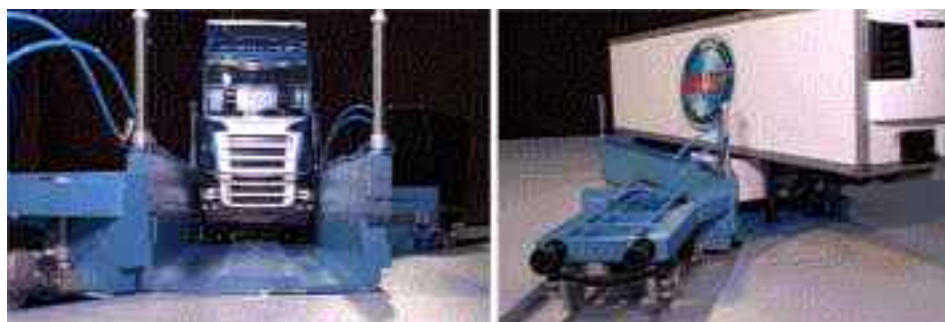

**Figure 2** Model of the special wagon for intermodal transport – selected views of the semitrailer loading from a railway ramp.

These analyses enabled to estimate the fluency of motions of the cooperating wagon mechanisms, made possible detecting of potential cuts and initial identification of critical states concerning the run of loading/unloading operations and a proper transport phase from constructional–operating point of view.

## 2 Numerical models of the special railway wagon for intermodal transport

### 2.1 Structure modifications and geometrical model of innovative wagon

An initial solution of the special railway wagon presented above is burdened with certain constructional problems. Firstly, mounting of the actuators in the side wall of the rotatable platform, connected with the still part of the wagon, reduce the loading capabilities of the wagon (a wagon can rotate only in one direction). Moreover, such position of the actuators as well as mounting vertical actuators driving pivotal locks (Figure 1) extorts conveying the wires powering the hydraulic elements through the central rotating junction of the platform. It increases significantly their length and also increases the risk of their wearing.

In connection with above, it was decided to modify the construction of the wagon so as to eliminate the mentioned problems concerning this solution.

The following constructional modifications were introduced in the next version of the wagon for intermodal transport:

- a changing of the mechanism of the platform body rotation,
- b modifications of the buckles connecting the body with the over–bogie part of the wagon frame,
- c changing of the body rotating platform (height and an open work construction of the tailboards, construction of the central bearing and rotation junction),
- d modifications of the structure of the over–bogies part of the wagon frame with a raceway of the rotatable platform.

All the main constructional modifications mentioned above were visualized and interpreted by descriptions in figures 3–6.

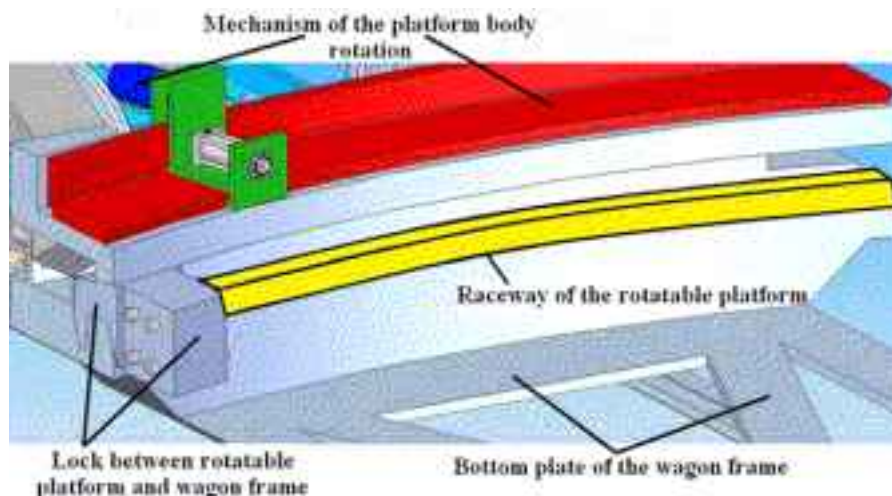
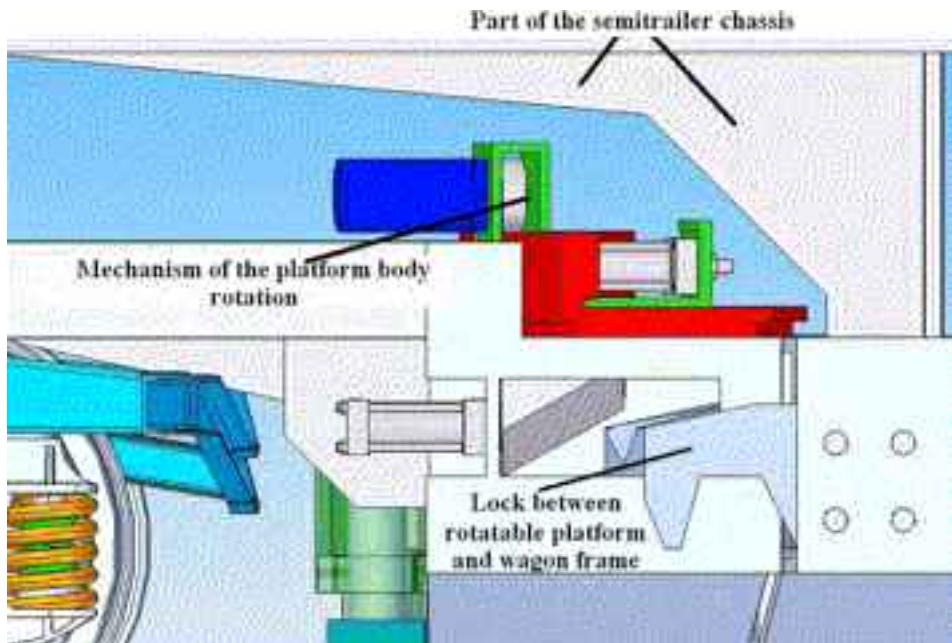
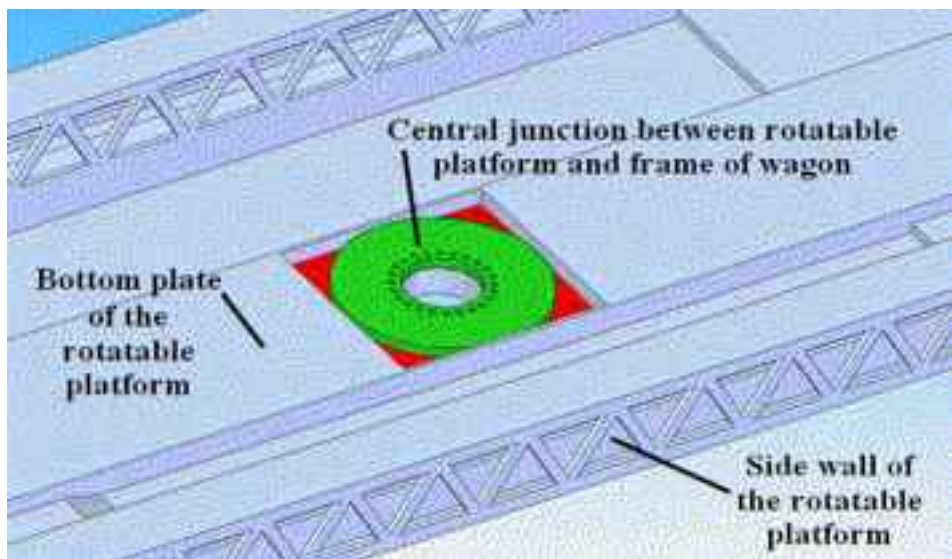

Figure 3 Geometrical model of the special wagon for intermodal transport – modifications of the mechanism of the platform body rotation.

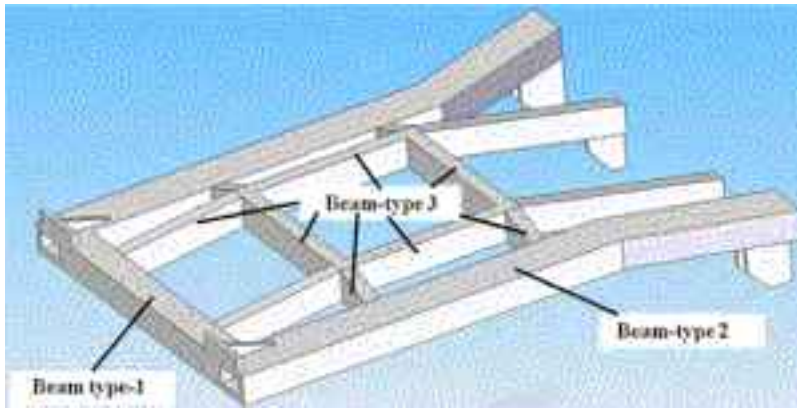



**Figure 4** Geometrical model of the special wagon for intermodal transport – modifications of the locks connecting the body with the over-bogie part of the wagon frame.



**Figure 5** Geometrical model of the special wagon for intermodal transport – modifications of the body rotatable platform.



**Figure 6** Geometrical model of the special wagon for intermodal transport – modifications of the structure of the over-bogie part of the wagon frame.

## 2.2 FE model of the special wagon with structure modifications

Selected problems of numerical analysis of the constructional solution of a wagon with a rotatable platform, with constructional changes taken into consideration, will be the object of considerations presented in the paper. The introduced constructional changes caused that wagon – unlike the prior version [4] discussed in the previous part of the study – became a symmetric construction. It was decided to use this fact and to conduct the calculations of a new version on the basis of  $\frac{1}{4}$  of the model. It should be underlined, that the range of constructional changes extorted preparation of a completely new mesh of finite elements [3]. The new numerical model, presented in Figure 7, consisted of 203650 nodes and approximately 200000 elements.



**Figure 7** FE model of the part of the wagon after constructional modifications – top and bottom views.

### 3 FE numerical analysis

#### 3.1 Some aspects of boundary conditions modelling

Based on the prior works, it was decided that the limiting variant for the wagon is the case of loading described in PN-EN 12663 standard [6] as 'the maximal service loading', depicted with a formula  $1,95 \times g \times (m_1 + m_2)$  where:  $m_1$  – mass of a vehicle body in the state ready to work,  $m_2$  – load allowed mass,  $g$  –  $g$  gravitational acceleration. In the numerical FE model, the standard [6] loading was implemented by applying inertia forces resulting from the value of the standard acceleration to the whole structure and by defining the load, of the value corresponding to the allowed mass of the vehicle semitrailer enlarged by a coefficient 1.95, acting on the central rotating junction (Figure 5). Due to taking into consideration the symmetry, the latter quantity was fourfold reduced. Deviation from the real areas of applying the loading (wheels of a semitrailer) was caused by the wish of maintaining the symmetry of the task. On the other hand, the considered case is more unfavourable in relation to the real one.

Just as in the case of previous analyses [4], boundary conditions in the king-pin are different than standard ones since besides displacements in the wagon plane, the possibility of the rotation around the longitudinal axis is taken away. This deviation results in the fact that deflection calculated during analyses presents significantly lower values, however, on the other hand, the strains in the structure (especially in an over-bogie part of the wagon frame) should be extorted.

The applied manner of the support can be treated as an attempt of taking into consideration other cases described in the standard [6] (for example, the case of lifting the wagon) and it is justified to the extend that the described analyses are purposed at supplying the information required for conducting constructional works but are not strictly verifying calculations.

#### 3.2 Numerical results

The selected results of analysis [3] of the structure of the wagon with a plate floor corresponding to the described in 3.1 section variant of boundary conditions are presented in Figure 8–9.

From the presented numerical tests, it results that it is still necessary to introduce some constructional improvements such as, for example, additional elements supporting work of the locks between the part of the rotatable platform walls and the over-bogie part of the wagon frame.

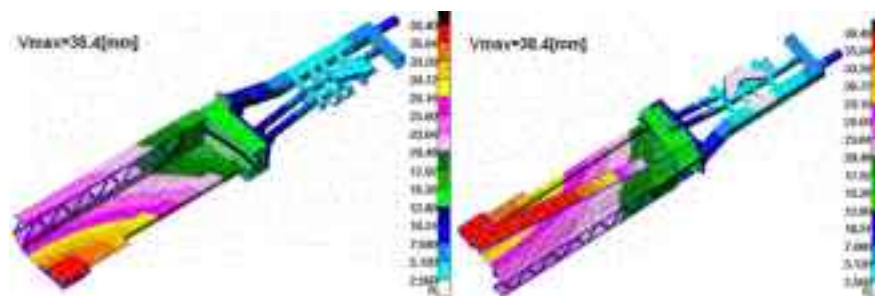

Figure 8 Maps of displacements – top and bottom views.

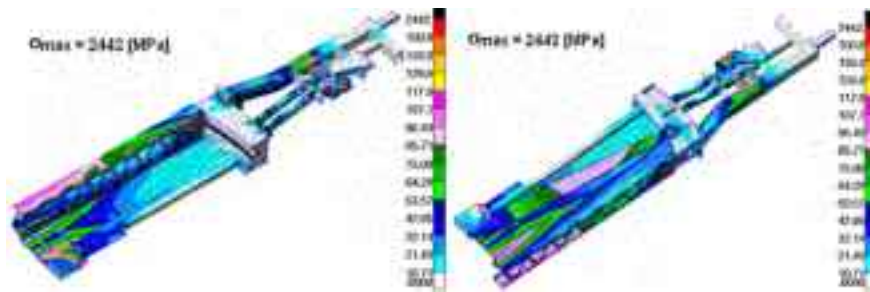

Figure 9 Maps of reduced HMM stresses – top and bottom views.

## 4 Summary

The methodology of numerical investigation, FEM models applied in the tests, verifying analyses and in simulating investigations of a wagon with a rotating platform and the obtained results are possible to be used in research – development works in the range of the design and modernization of such constructions in the scope of extending their service lives.

The developed methodology of examination of such a construction enables its implementation both at the stage of the design and during tests on already exploited or renovated constructions. Based on conducted analyses it can be verified that the proposed conception can meet the standard criteria included in PN-EN 12663 [6], however, some of its fragments require further analysis and tests. These elements are:

- optimization and strengthening of the construction of the over–bogie part of the wagon frame, especially modifications in the areas of mounting the tailboards joints of the rotatable platform, in which stresses concentrations occur locally,
- stiffening of the floor part of the rotating platform and optimization of the floor shape in order to limit deflection at loading with double masses – own and load,
- optimization of tailboards dimensions which, in the present form, are not strained, what allows to consider that in the optimization process it will be possible to significantly reduce their mass.

The work is financed by National Center of Research and Development – PBR R10 0023 06/2009 Presented constructional solution is protected by European patent application – EP 10461528

## References

- [1] Zhenfgang Lu, Hecht M.: Dynamic analysis of a new double deck passenger vehicle with bogie PW200, Technische Universität Berlin.
- [2] Matej J., Piotrowski J., Wojtyra M., Frączek J.: Modelling and safety examination of the long bimo dal train on curved track Rusing ADAMS/Rail, Institute of Vehicles, Warsaw University of Technology.
- [3] Zienkiewicz o. c, Taylor R.L.: The finite element method. V-edition, McGraw-Hill, London, 2000.
- [4] Niezgodą T., Krasoń W., Barnat W., Sławiński G.: Badania numeryczne rozwiązań prototypowych mechanizmu obrotu platformy wagonu kolejowego do przewozu naczep typu T1R, Problemy Kolejnictwa, Instytut Kolejnictwa, Zeszyt 153, str. 137-146, Warszawa, 2011, (in polish).
- [5] MSC.Patran/Marc, Manual, MSC, 2005.
- [6] PN-EN 12663: Railway applications - Structural requirements of railway vehicle bodies, Warsaw, 2002.



## 12 ENVIRONMENTAL PROTECTION



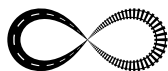

## DYNAMIC EFFECT OF MOVING LOAD ON ASPHALT PAVEMENT

Jozef Melcer, Gabriela Lajčaková

University of Zilina, Faculty of Civil Engineering, Slovak Republic

### Abstract

The roads represent the transport structures subjected to intensive dynamic effect of moving vehicles. The knowledge of the development of the strain and stress states in time is needed during the solution of various engineering tasks. One possibility how to obtain such information is to utilize the possibilities of numerical simulation methods of real processes. This advance demands the creation of vehicle computing models and pavement computing models. In this contribution the pavement computing model created on the theory of endless beam on elastic foundation is introduced. The goal of the calculation is to obtain the vertical deflection in one point of the pavement at the passing the vehicle and the time courses of vertical tire forces. The equations of motion are derived in the form of differential equations. The assumption about the shape of deflection curve on the generalization of experimental tests is adopted. It is assumed the validity of Maxwell theorem about mutuality of deflections. The equations of motion are solved numerically in the environment of program system MATLAB. The results following the influence of various parameters (speed of vehicle motion, stiffness of subgrade, modulus of elasticity, road profile) on the pavement vertical deflections and the vertical tire forces are introduced. The outputs from numerical solution in time domain can be transformed into frequency domain and subsequently employ for the solution of another tasks.

*Keywords: dynamic, computing models, asphalt pavement, vibration, tire forces*

### 1 Truck computing model

For the purpose of this contribution the plane computing model of the truck TATRA 815 is adopted, Figure 1. The computing model of the truck has 8 degrees of freedom – 5 mass and 3 massless. The massless degrees of freedom correspond to the vertical movements of the contact points of the model with the surface of the roadway. The vibration of the mass objects of the model is described by the 5 functions of time  $r_i(t)$ , ( $i = 1, 2, 3, 4, 5$ ). The massless degrees of freedom are coupled by the tire forces  $F_i(t)$ , ( $i = 6, 7, 8$ ), acting at the contact points. The equations of motions and the expressions for tire forcercs have the following form:

$$\begin{aligned}
 \ddot{r}_1(t) &= -\left\{k_1 \cdot d_1(t) + b_1 \cdot \dot{d}_1(t) + k_2 \cdot d_2(t) + b_2 \cdot \dot{d}_2(t) + f_2 \cdot \dot{d}_2(t) / d_{cv}\right\} / m_1 \\
 \ddot{r}_2(t) &= -\left\{-a \cdot k_1 \cdot d_1(t) - a \cdot b_1 \cdot \dot{d}_1(t) + b \cdot k_2 \cdot d_2(t) + b \cdot b_2 \cdot \dot{d}_2(t) + f_2 \cdot \dot{d}_2(t) / d_{cv}\right\} / l_{y_1} \\
 \ddot{r}_3(t) &= -\left\{-k_1 \cdot d_1(t) + b_1 \cdot \dot{d}_1(t) + k_2 \cdot d_2(t) + k_3 \cdot d_3(t) + b_3 \cdot \dot{d}_3(t)\right\} / m_2 \\
 \ddot{r}_4(t) &= -\left\{-k_2 \cdot d_2(t) - b_2 \cdot \dot{d}_2(t) - f_2 \cdot \dot{d}_2(t) / d_{cv} + k_4 \cdot d_4(t) + b_4 \cdot \dot{d}_4(t) + k_5 \cdot d_5(t) + b_5 \cdot \dot{d}_5(t)\right\} / m_3 \\
 \ddot{r}_5(t) &= -\left\{-c \cdot k_4 \cdot d_4(t) - c \cdot b_4 \cdot \dot{d}_4(t) + c \cdot k_5 \cdot d_5(t) + c \cdot b_5 \cdot \dot{d}_5(t)\right\} / l_{y_3}
 \end{aligned} \tag{1}$$



$$\begin{aligned}
 F_6(t) &= -G_6 + k_3 \cdot d_3(t) + b_3 \cdot \dot{d}_3(t) \\
 F_7(t) &= -G_7 + k_4 \cdot d_4(t) + b_4 \cdot \dot{d}_4(t) \\
 F_8(t) &= -G_8 + k_5 \cdot d_5(t) + b_5 \cdot \dot{d}_5(t)
 \end{aligned}
 \tag{2}$$

The meaning of the used symbols is as follows:  $k_i, b_i, f_i$  are the stiffness, damping and friction characteristics of the model,  $m_i, I_{yi}$  are the mass and inertia characteristics,  $a, b, c, s$  are the length characteristic of the model,  $g = 9,81 \text{ m}\cdot\text{s}^{-2}$ ,  $G_i$  are the gravity forces acting at the contact points. The deformations of the spring elements are  $d_i(t)$  and the derivation with respect to time is denoted by the dot over the symbol.

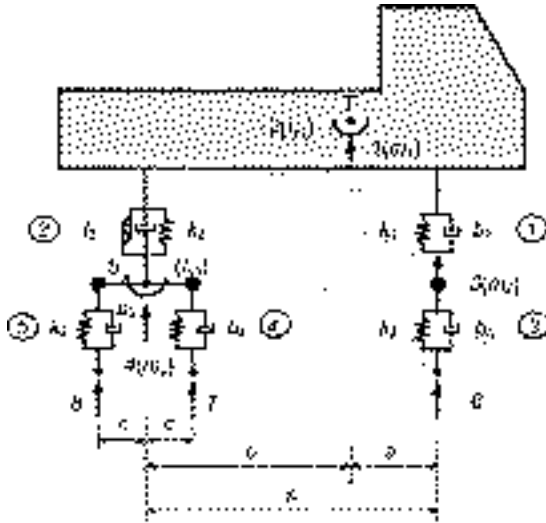

Figure 1 Truck computing model

## 2 Pavement computing model

The plane computing model of an asphalt pavement is based on theory of endless beam resting on Winkler elastic foundation [1]

$$El \frac{\partial^4 v(x,t)}{\partial x^4} + \mu \frac{\partial^2 v(x,t)}{\partial t^2} + 2\mu\omega_b \frac{\partial v(x,t)}{\partial t} + k \cdot v(x,t) = p(x,t)
 \tag{3}$$

The wanted function  $v(x,t)$  describing the beam vertical deflections will be expressed as the product of two functions

$$v(x,t) = v_0(x) \cdot q(t)
 \tag{4}$$

The function  $v_0(x)$  figures as known function and it is dependent on the coordinate  $x$  only and the function  $q(t)$  figures as unknown function and it is dependent on the time  $t$ . The function  $q(t)$  has the meaning of generalized Lagrange coordinate. With respect to the goal of the solution and with respect to the results of experimental tests the assumption about the shape of the function  $v_0(x)$  was adopted as

$$v_0(x) = \frac{1}{2} \left( 1 - \cos \frac{2\pi x}{l} \right) \quad (5)$$

The meaning of the other symbols is as follows:  $E$  modulus of elasticity [N.m<sup>-2</sup>],  $I$  cross section moment of inertia [m<sup>4</sup>],  $\mu$  mass intensity [kg.m<sup>-3</sup>],  $\omega b$  damping circular frequency [rad.s<sup>-1</sup>],  $k$  modulus of foundation [N.m<sup>-2</sup>],  $p(x,t)$  represents the continuous load in [N.m<sup>-1</sup>],  $l$  the length of the beam on which the deformation due to truck load occurs. With respect to the assumption (5) for plane computing model of the truck and for  $x=l/2$  the equation (3) can be rewritten to the form

$$\ddot{q}(t) \cdot \mu + \dot{q}(t) \cdot 2\mu\omega b + q(t) \left[ k + \frac{1}{2} E I \left( \frac{2\pi}{l} \right)^4 \right] = \sum_{j=6,7,8} F_j(t) \frac{1}{l} \left( 1 - \cos \frac{2\pi x_j}{l} \right) \quad (6)$$

### 3 Numerical analysis

#### 3.1 Parameters of the computing model

For the purpose of numerical analysis the following pavement construction was considered, Figure 2. The upper 3 layers of the pavement construction are considered as the beam with the height  $h = h_1 + h_2 + h_3 = 40 + 50 + 50 = 140$  mm = 0,14 m and the width  $b = 1,0$  m. For these 3 layers the equivalent modulus of elasticity and moment of inertia of the cross section were calculated

$$E = \frac{E_1 \cdot h_1 + E_2 \cdot h_2 + E_3 \cdot h_3}{h_1 + h_2 + h_3} = \frac{5500 \cdot 40 + 6000 \cdot 50 + 3050 \cdot 50}{40 + 50 + 50} \cong 4800 \text{ MPa},$$

$$I = \frac{1}{12} b \cdot h^3 = \frac{1}{12} 1,0 \cdot 0,14^3 = 2,2866667 \cdot 10^{-4} \text{ m}^4.$$

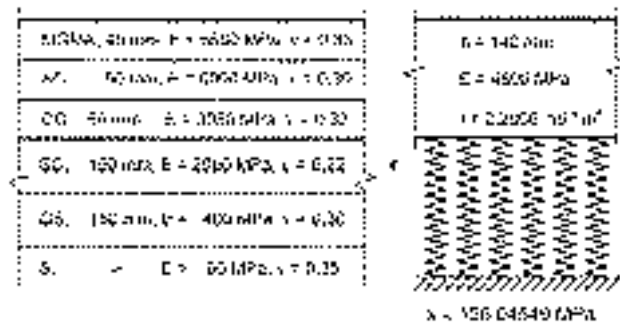

Figure 2 Pavement computing model, MGMA – medium grained mastic asphalt, AC – asphalt concrete, CG – coated gravel, SC – soil cement, GS – gravel sand, S – subgrade

The layers, No. 4 – 6, are taken into calculation as Winkler elastic foundation. The modulus of compressibility  $K=156,04549$  MN.m<sup>-3</sup> was calculated by the use of the program LAYMED [2]. The modulus of compressibility used at the beam computing model respects the beam width  $b$ ,  $k=K \cdot b=156,04549$  MN.m<sup>-3</sup> .  $1,0$  m =  $156,04549$  MPa. The mass intensity of the beam  $\mu=p \cdot b \cdot h=2200$  .  $1,0 \cdot 0,14 \cong 310,0$  kg.m<sup>-1</sup>. The damping circular frequency is taken as  $\omega b=0,1$  rad.s<sup>-1</sup>. These numerical data are considered as the base data.

#### 3.2 Influence of the speed of truck motion

For the numerical solution of the mathematical apparatus the computer program in the programming language MATLAB was created. The program enables the calculation of the time courses of all kinematical values of the truck (deflection, speed, acceleration), kinematical values at 1 point of the pavement and tire forces under the individual axles. The illustrations of the form of the obtained results are in Figures 3, 4.

The results of solution are influenced by various parameters of the considered system (speed of truck motion, stiffness of subgrade, modulus of elasticity of the beam, road profile, ...). The influence of the speed of vehicle motion was analyzed in the interval of speeds  $V = 0 - 120$  km/h with the step of 5 km/h. The maximums of vertical deflections at the monitored point of the pavement versus speed of the truck motion are plotted in the Figure 5. The results are obtained for the smooth road surface.

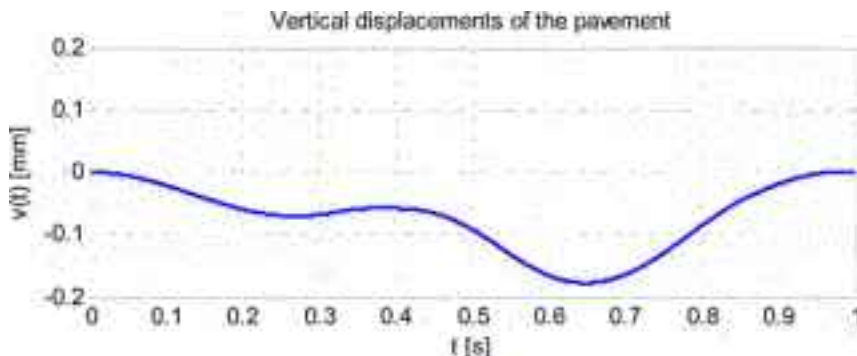

Figure 3 Vertical displacement of the pavement  $v(t)$ , speed  $V = 40$  km.h<sup>-1</sup>

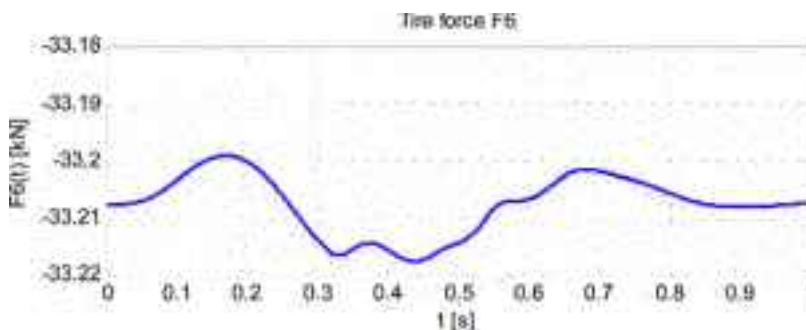

Figure 4 Tire force  $F_6(t)$  under front axle, speed  $V = 40$  km.h<sup>-1</sup>

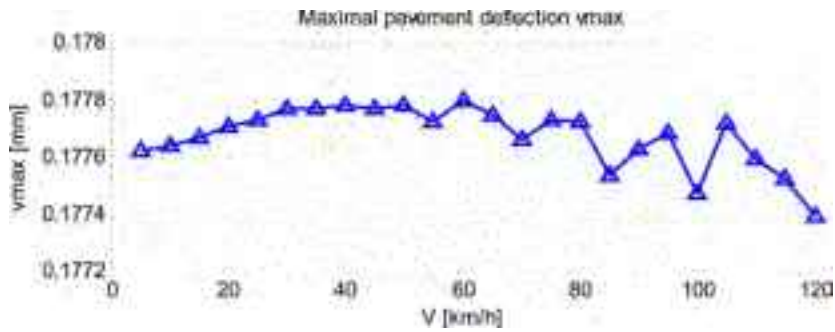

Figure 5 Maximal pavement deflection versus truck speed

### 3.3 Influence of the subgrade stiffness

The influence of the modulus of foundation  $k$  was analyzed in the interval 50–200 MPa with the step of 25 MPa and in the interval 200–500 MPa with the step of 50 MPa. The speed of vehicle motion was  $V = 60 \text{ km}\cdot\text{h}^{-1}$ . The maximums of vertical deflections at the monitored point of the pavement versus modulus of foundation are plotted in the Figure 6. Similarly the extremes (maximum, minimum) of tire force under rear axle versus modulus of foundation are plotted in the Figure 7.

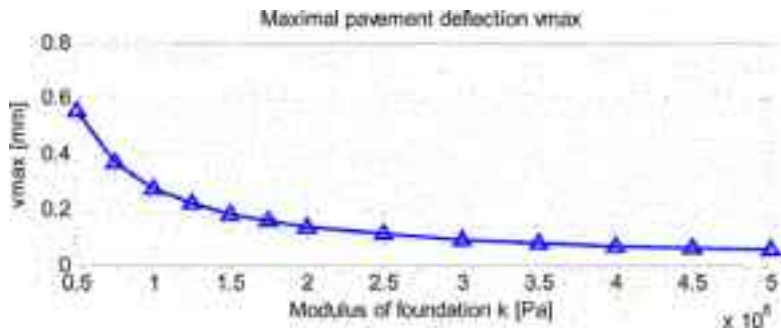

Figure 6 Maximal pavement deflection versus modulus of foundation  $k$

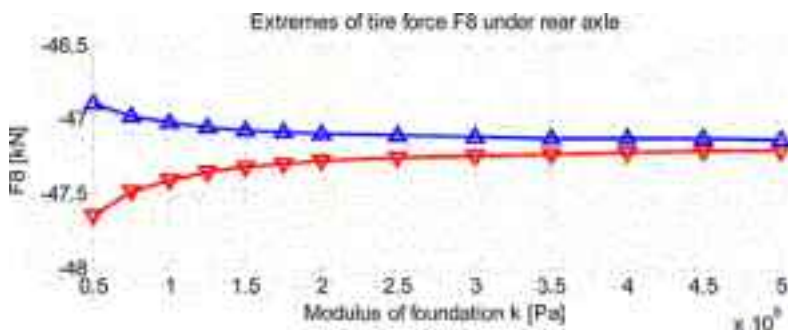

Figure 7 Extremes of tire force  $F_8(t)$  versus modulus of foundation  $k$

### 3.4 Influence of the beam modulus of elasticity

The influence of the beam modulus of elasticity  $E$  was analyzed in the interval 2000–7000 MPa with the step of 500 MPa. The speed of truck motion was  $V = 60 \text{ km.h}^{-1}$ . The maximums of vertical deflections at the monitored point of the pavement versus modulus of foundation are plotted in the Figure 8. Similarly the extremes (maximum, minimum) of tire force under rear axle versus modulus of foundation are plotted in the Figure 9.

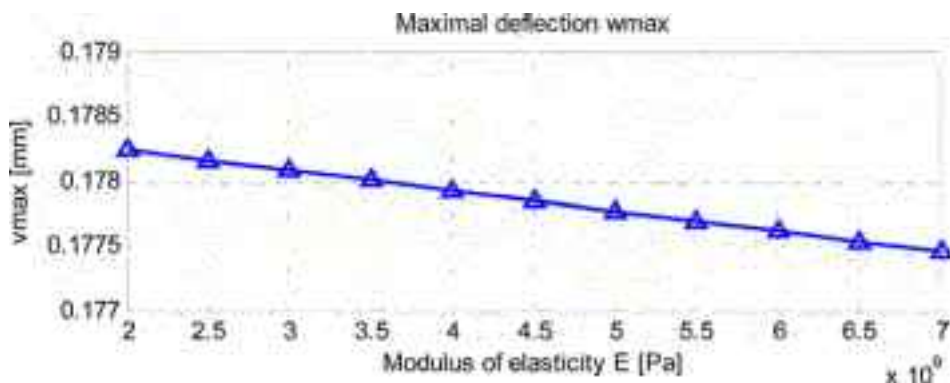

Figure 8 Maximal pavement deflection versus beam modulus of elasticity  $E$

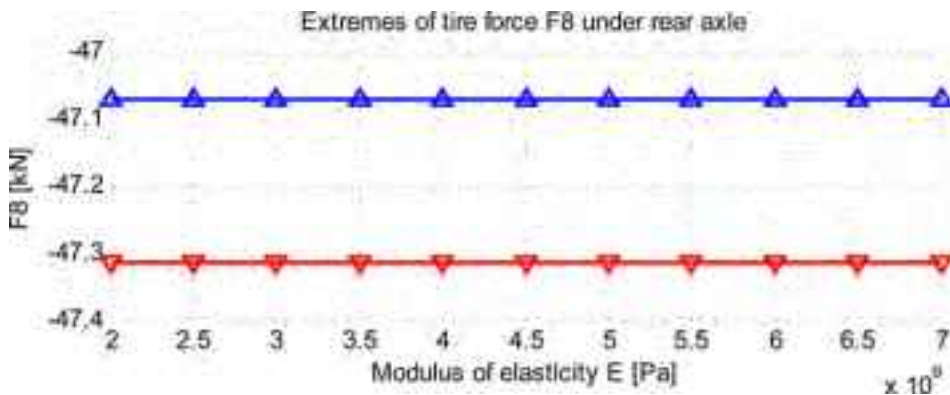

Figure 9 Extremes of tire force  $F_8(t)$  versus beam modulus of elasticity  $E$

### 3.5 Influence of the road profile

The above-mentioned results were obtained for the smooth road profile. The real road profile has stochastic character and it represents the dominant source of kinematical excitation of vehicle. Also the vehicle response has stochastic character. The results of solution can be presented in time or in frequency domain. The influence of quality of the road profile on the tire forces is followed in this paper. As an example the tire forces under front axle  $F_6(t)$  and their power spectral densities evaluated for very good profile ( $\Phi_0 = 4 \cdot 10^{-6} \text{ m}^2/(\text{rad}/\text{m})$  [3]) and average profile ( $\Phi_0 = 64 \cdot 10^{-6} \text{ m}^2/(\text{rad}/\text{m})$  [3]) are presented in the Figure 10, 11.

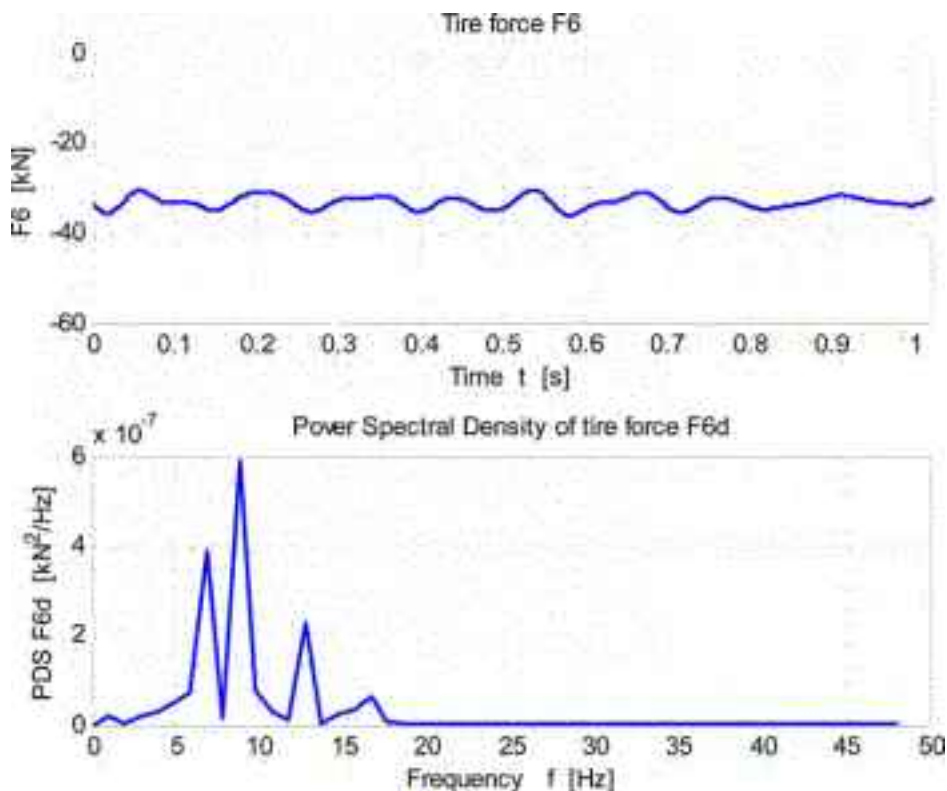

Figure 10 Tire force  $F_6(t)$  and its PSD,  $\Phi_0 = 4 \cdot 10^{-6} \text{ m}^2/(\text{rad}/\text{m})$

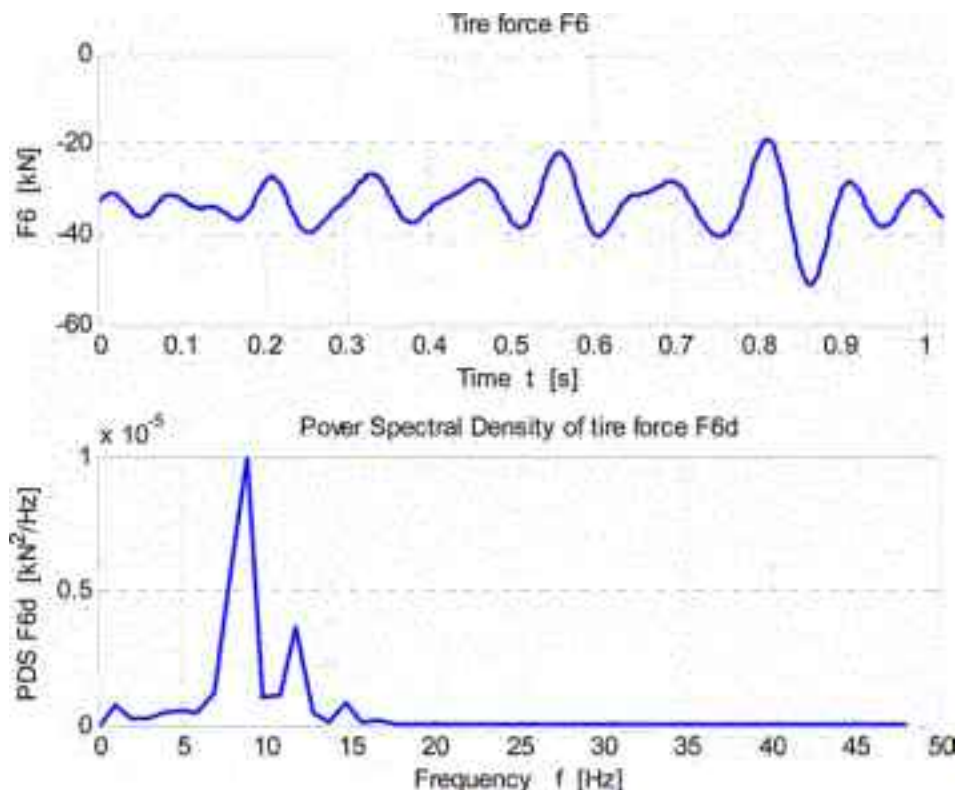

Figure 11 Tire force  $F_6(t)$  and its PSD,  $\Phi_0 = 64 \cdot 10^{-6} \text{ m}^2/(\text{rad/m})$

## 4 Conclusion

Computing model of the road based on the theory of beam on elastic foundation with adopting the assumption about the shape of bending elastic line provides the effective tool for the solution of many dynamic problems in time domain. Numerical solution can be realised in the environment of the program system MATLAB. The outputs from numerical solution in time domain can be transformed into frequency domain and subsequently employed for the solution of another tasks.

This paper was supported by the Grant National Agency VEGA, project 1/0259/12.

## References

- [1] Frýba, L.: Vibration of Solids and Structures under Moving Loads, ACADEMIA Praha, Noordhoff International Publishing, Groningen, 1972.
- [2] Novotny, B., Hanuska, A.: Theory of layered half-space (in Slovak), VEDA, SAV, Bratislava, 1983.
- [3] ISO 8608, Mechanical vibration – road surface profiles – reporting of measured data, International Standard (iso), 1995.

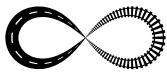

## THE FEASIBILITY OF PIEZOELECTRIC ENERGY HARVESTING FOR CIVIL APPLICATIONS

Simon C. Bos

*Tauw bv, The Netherlands*

### Background of piezoelectricity

Piezo means pressure in Greek. Piezoelectricity is the generation of an electric field when pressure is applied to a certain material. The piezoelectric effect was first discovered by the Curie brothers in 1880. But this technology wasn't implemented to a product until 1921. Like many inventions there is time between the discovery and practical use. This is mainly because of the advantages of already optimized competing technology. In addition, new technology has to show great benefits before it will be accepted. In 1924 piezo was used for the first time in radio transmitters and at the end of 1930 all transmitters were equipped with piezoelectric crystals. The major introduction of piezoelectric material was by the discovery that the mixed oxide compound barium titanate ( $\text{BaTiO}_3$ ) can be made piezoelectric. With an electric poling process the material gains its piezoelectric properties which are much stronger than the natural quartz crystal. In 1947 the first  $\text{BaTiO}_3$  piezoelectric based phonograph pickups appeared on the commercial market. The strong piezoelectric effect of lead zirconate titanate (PZT) was discovered in 1954 and is until today a leading material for piezoelectric applications. The piezoelectric effect in polymers was first discovered in 1969 on poly vinylidene fluoride (PVDF) [1].

### 1 Working principle of piezoelectricity

The direct piezoelectric effect is a changing of the shape that gives an electric potential. The converse piezoelectric effect is an electric field that changes the physical shape of the material (see figure 1).

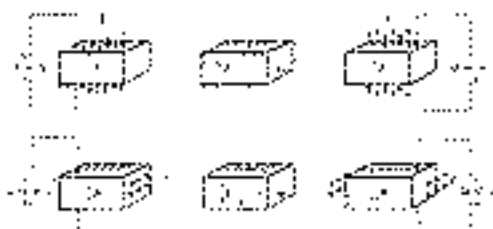

Figure 1 Basic working principle of piezoelectricity

In our opinion the direct piezoelectric effect is most interesting. There are several ways to use the direct piezoelectric effect as you can see in figure 1. In this figure the poling direction is displayed together with the direction of the force. The upper three pictures represent a force applied in the poling direction alongside with the equations for the calculation of the corresponding charge or voltage. The applied force creates direct extension or compression and is best converted with a piezoelectric ceramic (left picture in figure 2). This piezoelectric stack contains multiple layers of piezoelectric material, stacked on to each other to generate a higher energy output.

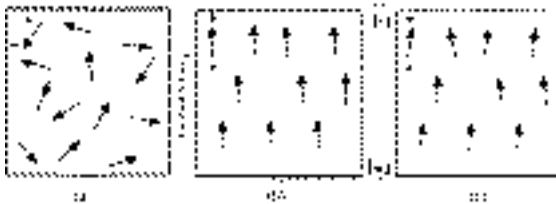



**Figure 2** Examples of piezoelectric material

The lower three pictures of figure 1 show a force applied in the transverse direction. In general this is achieved by attaching the piezoelectric material to another material. When this material is bent, the piezoelectric material will indirectly be compressed or elongated. The flexible polymer material is a suitable material because it can resist high strain (see the middle and the right in figure 2).

There is a relation between electric charge and pressure. This phenomenon is caused by the piezoelectric dipole moment found in some materials [2]. An electric dipole is present in a material when the centers of the positive and negative charges are not matching. When the atomic structure of the material is non-centrosymmetric a dipole can be formed. Without a centre of symmetry the dipoles will not exclude each other and can develop a polarization. Before subjecting a material to external stress, the centers of gravity of each positive and negative charge fit together. The contribution of both positive and negative charge exclude, which results in an electrically neutral material. When subjecting the material to stress, a separation of the gravity centers of the positive and negative molecules is created. This separation creates little dipoles and generates a polarization direction [3]. Some materials that naturally have piezoelectric properties are quartz, rochelle salt and cane sugar. There are also man-made materials with piezoelectric properties like PZT (lead zirconate titanate), barium titanate and the polymer PVDF (polyvinylidene fluoride). A strong electric field is applied to the ferroelectric ceramics when heated for the poling process. After this process groups of dipoles are formed with all more or less the same poling direction. In this way a strong piezoelectric effect is produced (figure 3) [4].



**Figure 3** Polling of piezoelectric material [4]

## 2 Applications of piezoelectricity

Piezoelectric material can be used as a sensor, actuator or as a transducer, which acts both as sensor and actuator. Piezoelectricity is used in many products both using the direct and converse piezoelectric effect. Products using the direct effect act as a sensor, for instance as a strain, pressure or acceleration sensor. Good everyday examples are the electronic drum pad, guitar pick-up or electric lighters. When using the converse piezoelectric effect, the material is functioning as an actuator. Everyday examples of actuators are found in buzzers used in smoke detectors and ejecting ink with inkjet printers. Piezoelectric actuators are also useful in accurate positioning systems. Because of the small changes in dimension when using a strong electric field, these actuators are for example suitable for the focusing of lenses of cameras. Figure 4 gives an overview of applications of piezoelectricity in different areas.

Communications and control	Industrial	Health and consumer	Newer applications
<ul style="list-style-type: none"> <li>• Cellular radio</li> <li>• Television</li> <li>• Automotive radar</li> </ul>	<ul style="list-style-type: none"> <li>• Transducers</li> <li>• Sensors</li> <li>• Actuators</li> <li>• Pumps</li> <li>• Motors</li> </ul>	<ul style="list-style-type: none"> <li>• Transducers</li> <li>• Sensors</li> <li>• Actuators</li> <li>• Pumps</li> <li>• Motors</li> </ul>	<ul style="list-style-type: none"> <li>• Smart Structures</li> <li>• High Displacement</li> <li>• Transducers</li> <li>• Mixed-effect Devices</li> </ul>
<ul style="list-style-type: none"> <li>• Signal processing</li> <li>• Oscillators</li> <li>• Frequency control and timing</li> <li>• Correlators</li> <li>• Convolvers</li> <li>• Filters</li> <li>• Delay lines</li> </ul>	<ul style="list-style-type: none"> <li>• Ultrasonic cleaning</li> <li>• Vibration damping</li> <li>• Sonar</li> <li>• Liquid level sensors</li> <li>• Non-destructive evaluation (NDE)</li> <li>• Material properties determination</li> <li>• High temperature sensors</li> <li>• Chemical/biological sensors</li> </ul>	<ul style="list-style-type: none"> <li>• Non-invasive medical diagnosis</li> <li>• Hypertension</li> <li>• Lithotripsy</li> <li>• Wrist-watches</li> <li>• Subcutaneous medications</li> <li>• Camera focusing/steering/ranging</li> <li>• Computer timing/printing/modems</li> <li>• Ignition of gases ("spark pump")</li> </ul>	<ul style="list-style-type: none"> <li>• Microelectromechanical (MEMS) devices</li> <li>• Microoptomechanical (MOMs) devices</li> <li>• Biomimetic devices</li> <li>• Random devices</li> <li>• Acousto-phononic-electronic devices</li> <li>• Composite and functionally graded devices</li> </ul>

Figure 4 Applications of piezoelectric materials in different areas

Three basic principles can be recognized in which the energy harvesting concepts can be categorized as shown in figure 5. Those basis concepts help to generate concepts and help to understand the working principle of the energy conversion. Several concepts can be created from each category of vibration sources. Minor variations in the three models can be applied to adjust the principle to create the best suitable solution for the specific vibration. The goal is to look for opportunities for piezoelectric energy harvesting in the civil world. The input for harvesting energy is a vibration which can be found everywhere as seen in figure 6.

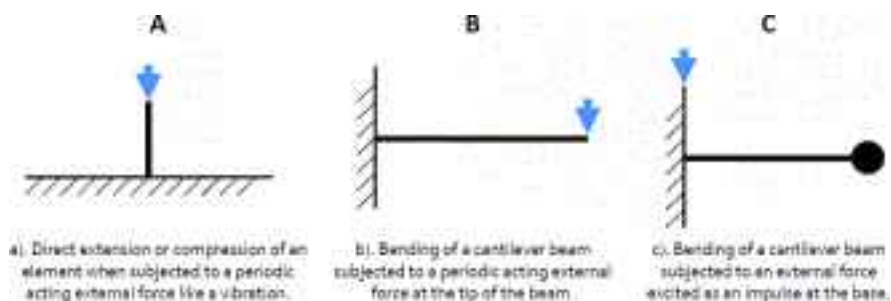

Figure 5 Basic principles of energy harvesting concepts



Figure 6 Examples of vibrations in a city

### 3 Pilot project on the N34, the Netherlands

#### 3.1 The goal of 'Mooi Nederland'

One of the policy goals of the Dutch government stimulated with subsidy, is 'Mooi Nederland' (Beautiful Holland). The achievement for this initiative is in the scope of sustainability and alternative energy. For this master project, this is an interesting initiative to exhibit the use of piezoelectricity. The goal of 'Mooi Nederland' is that people from The Netherlands should appreciate the landscape more. The Dutch Ministry has started a subsidy arrangement for innovative projects to invest in spatial quality. In 2010 one of the three themes is Identity of energy landscapes. The Ministry is especially searching for actual projects on a local and regional scale where renewable energy is combined in a nice way with other functions.

#### 3.2 Project implementation

The initiative of 'Mooi Nederland' was very interesting, so we decided to send in one of the concept directions in an attempt to obtain subsidy. Together with the University of Twente and the province of Overijssel a project will be set up. The main objective of the project is to harvest useful energy, by means of undesirable vibrations in the civilian world. This will be done by using piezoelectric materials. This method of renewable energy production has not yet been applied in the civilian world. Tauw and the University of Twente are investigating the possibility to reuse the energy lost in vibration on roadways. With the help of a pilot project the feasibility will be tested. The project started as a graduation project to examine the feasibility of piezoelectric energy harvesting into the civil world. Piezoelectric material can convert strain into an electric charge. With high alternating strain a significant amount of energy can be generated to power small electric circuits. In other words, the energy of a vibration is partly needed to produce electric energy. Traffic loses a part of its energy in friction of the tires and the road. This lost energy is dissipated as heat into the ground. A fraction of this lost energy can be used to generate electricity for a better use. In a pilot project piezoelectric ceramics will be positioned below the road surface. A vibration will be produced when traffic past the installation and as a result generating energy. The goal of the pilot project is to acquire information about the energy output and the performance of the product subjected to environmental factors. The key is to produce energy at locations where unwanted vibrations already exist. An example of this could be at places with seams in the road or with bridges. Since piezoelectric material is behaving as a damper, the supports of bridges can be equipped with piezoelectric

material to generate electric energy. The energy can be used to power sensors, road signs or lighting. In the pilot project the energy will be monitored and used to power a sign to inform people about the project or the energy production. After a few months the gained knowledge will be used and the project viability will be assessed.

### 3.3 The first results

This project has been rewarded with a subsidy in the past of 2010 to run a pilot. The pilot was tested at the N34 in 2011. The province of Overijssel wants to change this road and wants to improve the safety. Sustainability is an important part of the reconstruction. And piezoelectric energy harvesting may contribute to realise this goal.

For the pilot, it's important that we are looking for the connection between energy and traffic. Therefore, we also collected data from the traffic on this road as 1) how many cars passed, 2) what types of cars passed, 3) what is the speed of the cars passing the pilot, etcetera. In future, the speed of the cars on the 'new' N34 may be 100 km per hour. Therefore it was decided to do the pilot on a section, where the maximum speed of cars on this moment is 100 km per hour.

The chosen location on the N34 (the east of the Netherlands) is nearby a measurement for traffic information. Figure 7 gives an overview of the location.



**Figure 7** Location of the pilot

The construction consists of a beam, which is build in the road, as you can see in the photo of figure 7. When a car drives over the beam, it presses a threshold of 3 mm with its wheels. The height of 3 mm is related to the thickness of the stripes on the Dutch roads. They are about 3 mm high as well. The car driver doesn't feel the threshold as an extra hurdle. If a car drives over the beam, the beam will be declined and the piezoelements will be vibrated. When the beam comes back of the pressure, the piezoelements will be vibrated again and they generate energy.

The first interpretation gives good results [5]. There is a good connection between the traffic and the generated energy. Figure 8 shows the results of two beams on Friday, 4 November 2011. The most energy is harvested between 5 an 20 o'clock, with elevated peaks around 6 to 9 o'clock and around 15 to 18 o'clock. Those times are the peak hours on the roads.

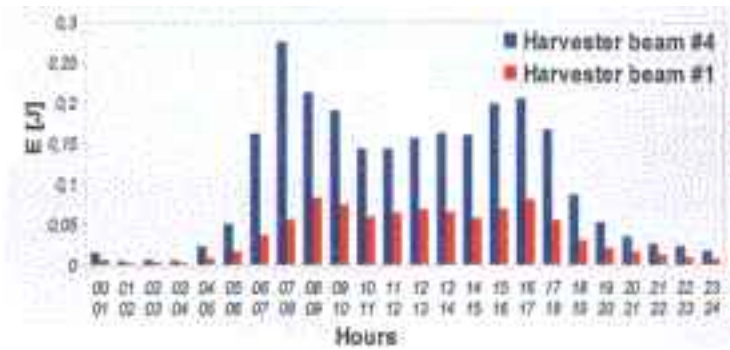
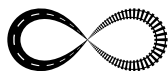

Figure 8 Power distribution for Friday, 4 November 2011

## References

- [1] Heywang, W., Lubitz, K., Wersing, w. (2009). Piezoelectricity: Evolution and Future of a Technology, Springer.
- [2] Preumont, A. (2006). Mechatronics: Dynamics of Electromechanical and Piezoelectric Systems. Brussels, Springer.
- [3] Arnou, A. (2008). Piezoelectric transducers and applications, Springer.
- [4] Moheimani, S. O. R., Fleming, A. J. (2006). Piezoelectric Transducers for Vibration Control and Damping, Springer.
- [5] Heunink, R. (2012). Energy harvesting in traffic with piezoelectric material.



## RAIL ROUGHNESS MEASUREMENT AND ANALYSIS IN FRAME OF RAIL VEHICLE PASS-BY NOISE MEASUREMENTS

Stjepan Lakušić<sup>1</sup>, Ivo Haladin<sup>1</sup>, Ante Jukić<sup>2</sup>, Nikola Andrašić<sup>1</sup>, Petar Piplica<sup>3</sup>

*1 University of Zagreb Faculty of Civil Engineering, Dpt. of Transportation, Croatia*

*2 Ruđer Bošković Institute, Division of Laser and Atomic R&D, Croatia*

*3 Inspekt d.o.o., Laboratory for Acoustical Measurements, Croatia*

### Abstract

Railway rolling noise emerges from combination of wheel and rail surfaces roughness. Previous researches evaluated roughness of running surface as the main cause of railway vehicles noise from 60 km/h up to 250 km/h running speed. As an example, rail welds or local irregularities on rail running surface may cause an increase of noise up to 4 dB(A) for the same running speed. Railhead roughness therefore became important parameter in order to conduct typical vehicle passing-by noise measurements. Within European Union's strategy for harmonization of internationally running train services where developed new standards, as EN ISO 3095 or TSI-Noise, to set limits on the noise emitted by individual rail vehicles. Their requirement is "roughness level test" performed on a 'reference track' to confirm its influence on external passing-by vehicle noise.

This paper describes standard rail roughness measurement procedure on 'test sections' selected in order to determine passing-by noise of a new low floor EMV train constructed by Končar – Electric Vehicle for Bosnia and Herzegovina Federal Railways. It is mainly concentrated on measured data analysis according to European standards. Rail roughness with a broad spectrum of wavelengths is always present on the running surfaces of the rails and it has been shown that there is a high dependence between the amplitude and the wavelength of the roughness. Therefore, according to the standards above, measurements have been performed with device that measures wavelengths from 0.1 up to 0.63 m. The track quality had to satisfy a rail roughness limit set by EN ISO 3095 based on one-third octave bands. Collected data needed to be filtered and grouped for further evaluation. The result of that spectral analysis is presented as a spectrogram which determined tested section as valid for further typical pass-by noise measurements.

*Keywords: rail roughness, measurement, spectral analysis, rail vehicles*

### 1 Introduction

In 1996 an estimated 20 % of population of Western Europe lived in the area with ambient noise levels over 65 dB, and over 60 % in the area with noise levels over 55 dB. These facts led to several reactions, by public as well as experts throughout Europe, which resulted in joined effort of member countries in forming unified policy on noise in the environment.

Environmental Noise Directive (END – directive 2002/49/EC) [1] issued in July 2002. Directive has a clear approach to environmental noise issue and requests prevention, avoidance and mitigation of harmful environmental noise effects. Basic requirements of the directive are synchronizing the procedure of noise mapping and noise maps themselves, determining total number of residents exposed to excessive noise levels and informing the public and European

Commission on the current state and financing of noise management measures. For railway authorities and infrastructure management systems, noise mapping and action plans imply having to evaluate the means of reducing the railway traffic noise to acceptable levels. Since unified method has not yet been established, European commission has adopted interim guidelines [2] for railway noise map generation based on Dutch RMR, until a unique method is developed under projects Harmonoise and Imagine.

Regardless of the method for determining the exposure of surrounding population to elevated noise levels, efficient and quality solutions for noise mitigation have to be based on detailed analysis of all the elements that produce the noise. Railway borne noise can be decomposed to several main sources such as engine noise, wheel rail interaction, and aerodynamics. Therefore it is possible to influence two critical emission elements: vehicles and infrastructure. Special problem arises when trying to determine the share of each noise emission element while conducting pass-by noise measurements. This is particularly obvious when testing newly constructed rail vehicles, which according to action plans on noise mitigation have to comply with the eligible standards. In the effort to precisely determine noise emission levels, when testing railway vehicles it is essential to determine the contribution of each noise emission source to the overall noise levels. This procedure, beside standard pass-by noise measurements, requires additional measurements such as rail surface roughness measurements which are covered by this paper.

## 2 Rolling noise

Rolling noise is noise originated at the wheel-rail interface. From the definition itself, it is clearly visible that the mentioned noise is caused by irregularities that appear both on a wheel and rail running surface. It is therefore almost impossible to examine this issue from the aspect of just one component, but with today's knowledge it is possible to determine the contribution of each component in the overall rolling noise with high accuracy. Regardless of the component that contains irregularities, they significantly increase vibrations of the moving vehicle, and can often cause elevated noise levels in the environment. Previous researches evaluated roughness of running surface as the main cause of railway vehicles noise from 60 km/h up to 250 km/h running speed, [3]. Rail roughness with a broad spectrum of wavelengths is always present on the running surfaces of the rails and it has been shown that there is a high dependence between the amplitude and the wavelength of the roughness, [4]. Researches indicate that the variance in rail roughness can influence the railway vehicle pass-by noise level up to 20 dB(A). Railhead roughness therefore became important parameter in order to conduct typical vehicle passing-by noise measurements according to EU standards and directives. [4, 5]

## 3 Rail roughness measurements

Generally, methods for measuring rail running surface roughness can be divided into direct and indirect. Indirect methods are based on measuring vibrations induced by wheel-rail interaction. Shortcoming of this method lays in the fact that it is quite difficult to distinguish vibrations induced by wheel irregularities and rail running surface roughness. Additional shortcoming of indirect roughness measurements is the need of installing expensive equipment on the existing measuring vehicle or acquiring a new measuring vehicle. This measuring method, usually performed using accelerometers fitted to vehicle axle, can acquire data on irregularities of higher wavelength opposed to direct measurement method which gather data on irregularities of shorter wavelengths. Therefore they are suitable for measurements on high-speed railway tracks. Data gathered by indirect roughness measurements can vary up to 3 dB(A) in spectral analysis, as a consequence of rough differentiation between vibration caused by wheel or rail imperfections.

In common engineering practice there are four possible reasons for conducting rail roughness measurements:

- test track measurements with the purpose of conducting pass-by noise tests,
- determining the need for rail grinding,
- determining the state of rail surface as an input for noise map calculation,
- roughness growth monitoring.

Direct roughness measuring method is conducted using mobile transducer based measuring instruments. Due to slow pace of the measuring procedure (measurements are usually taken repeatedly on ~1 m long stretch of track) it is not suitable for evaluation of large railway network segments, but for shorter test sections. Due to greater accuracy (estimated maximal error of 1 dB(A)) direct method is appropriate determining the influence of rail roughness on overall noise levels when conducting pass-by noise measurements. This method will further be elaborated in the scope of this paper. Namely, within the European Union's strategy for harmonization of internationally running train services new standards and specifications such as EN ISO 3095 and TSI-Noise [4, 5] have been developed, in order to set limits on the noise emitted by individual rail vehicles. They elaborate test section measurement procedures, requirements for measuring instruments and data processing.

### 3.1 Measurement procedure

Type noise measurements of railway vehicles have to be conducted on a referent test track in order to eliminate the influence of different irregularities that could affect noise measurement outcome. However, if such test track is not available, it is possible to perform the measurements on a railway track in exploitation if it meets the required condition of geometrical configuration, surrounding environment, rail roughness etc. described in [5].

A 100 m long test section has been identified along the Vrpolje – Ivankovo railway line. This section has been chosen by its geometry features that would enable typical pass-by noise measurements of a new EMV ŽFBH 4412 made by Končar Electric Vehicles [7] at speeds of up to 160km/h. Standard track geometry measurements according to [8] have been conducted on the test section resulting with valid track geometry (average track gauge of 1433.11 mm and cant of 1.09 mm).

According to [5] the test section complies with the described conditions: measurements shall be made with ballast bed and wooden or reinforced concrete sleepers, the track shall be dry and not frozen, the tests shall be done on a rail section and sleeper design in common use on the particular railway network, the level gradient at the track shall be 3:1 000 at the most and the radius of curvature  $r$  shall be  $> 5000m$  ( $v > 120$  km/h), Figure 1.



Figure 1 Test section on Vrpolje – Ivankovo railway line with tested EMV



The track at the measuring section also had to be laid without rail joints (welded rail) and free of visible surface defects such as rail burns or pits and spikes caused by the compression of external material between wheel and rail: no audible impact noise due to welds or loose sleepers should be present. It had to be clear of any reflecting surfaces such as buildings or fences in the near vicinity. Direct roughness has been measured along the whole section of 100 m to gather as much data for further analysis and comparison. Instrument used for measurements was RAILPROF 1000 (Figure 2). The instrument logs the data on 1 m long sections so it took total of 400 measurements to cover the 100 m long section of a double-track railway line.

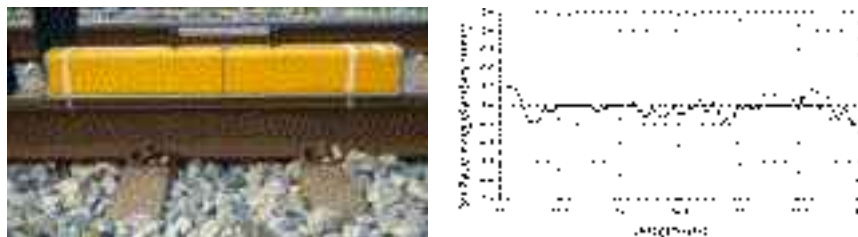

Figure 2 Measuring instrument RAILPROF 1000 and raw data output

Further data analysis has been performed on data extracted at these measuring locations suggested by [5] in respect to the position of pass-by noise measuring instrument. In total 24 measurements (12 per track) have been extracted for further analysis.

#### 4 Rail roughness data analysis

Data acquired by direct roughness measurements represents the running surface of the railway track measured at the distance of 0.5 cm from each other (200 measuring points per 1 m). Since measurements of rail roughness have been conducted with 1 m long measuring device, wavelengths up to 0,1 m have been taken into account according to [5]. In order to determine roughness levels the data processing has been accomplished using MATLAB programming environment. The analysis process itself is composed out of two steps: (1) removing the peaks from the raw measured data and (2) spectral analysis of the data.

High peaks which do not influence the actual wheel-rail interaction had to be removed prior to spectral analysis because they can influence the spectrum and lead to conclusion on inappropriate running surface. Several techniques have been suggested for non linear filtering which basically differ in the shortest spectrum wavelength, [9], [10]. Used technique consisted of local smoothing with weighted linear least squares and first degree polynomial. It is important to note that peak removal techniques are still not standardized and represent the area of intensive research.

The goal of the spectrum analysis is representing measured data in a form similar to noise measurement results. General idea is to decompose the signal to frequency bands interesting for the analysis. Commonly used method for data representation is one-third octave power density spectrum. The spectrum analysis can be performed by applying Fourier transform or band filtering representing the data in one-third octave ranges according to standard [11]. Butterworth filters, continued according to the standard, have been used with central frequencies determined according to [12], Figure 3.

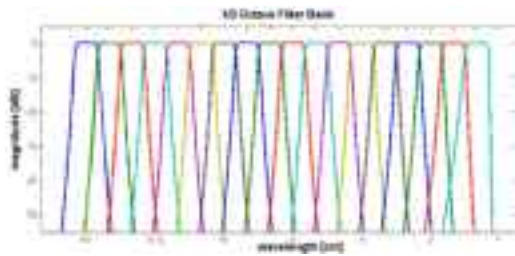

**Figure 3** Spectral characteristics of the filter bank

Designed filter bank has been used for decomposition of original roughness signal to frequency ranges of certain width. Equivalent mean values of the output signal of each filter represent the absolute level of roughness for each one-third octave with central wavelength of  $l$ , expressed as:

$$r(\lambda) = \sqrt{\frac{1}{n} \sum_{k=1}^n r_k(\lambda)},$$

where  $n$  is the number of samples and  $r_k(l)$  the sample at the filter output that corresponds to wavelength  $l$ . To compare the data to limits set by [5], logarithmic values have been calculated for each wavelength  $L_r(l)$  in dB according to expression:

$$L_r(\lambda) = 10 \log \left( \frac{r(\lambda)}{r_0} \right)^2,$$

where  $r_0 = 1 \mu\text{m}$  of reference roughness.

Final results of spectral analysis are shown in the following figure for each railway track. In respect to the standard limits the southern railway track can be evaluated as valid for further typical pass-by noise measurements, Figure 4.

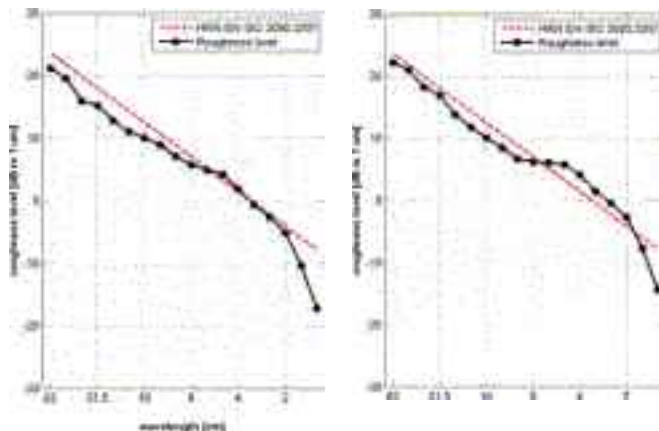

**Figure 4** Results of spectral analysis of both railway tracks at the test section (southern on the left and northern on the right)

## 5 Conclusion

Dominant component of railway born noise is the noise produced by wheel-rail interaction at the operation speed of 50 to 250 km/h, [3]. Track maintenance is a crucial component of safe and reliable railway network operation. By measuring and evaluating rail surface roughness it is possible to perform on time rail grinding achieving cost saving and smooth operation of the railway network.

For the purpose of typical noise measurements of EMV ŽFBH the reference track on Vrpolje – Ivankovo railway line has been analysed. From the aspect of track geometry, both northern and southern tracks have been evaluated as suitable for typical pass-by noise measurements. However, from the aspect of rail roughness, only the southern railway track has been declared suitable for the mentioned noise measurements.

This kind of roughness measurements and analysis procedures are required for all the railway sections selected for typical noise measurements, whether they are being used for testing new or existing railway vehicles and equipment.

## References

- [1] Directive 2002/49/EC of the European Parliament and of the Council relating to the assessment and management of environmental noise, Official Journal of the European Communities, 2002.
- [2] E. Verheijen, Using source separation techniques in measuring railway noise emission, InterNoise 2004, 2004.
- [3] P. A. Meehan, "Railway Noise and Control," Mech3250 presentation.
- [4] D. Thompson, Railway Noise and Vibrations. Elsevier Ltd, 2009, p. 519.
- [5] HRN EN ISO 3095:2007 Railway applications – Acoustics – Measurements of noise emitted by railbound vehicles
- [6] Directive 2006/66/EC Commission Decision of 23 December 2005 concerning the technical specification for interoperability relating to the subsystem 'rolling stock – noise' of the trans-European conventional rail system, Official Journal of the European Union, 2006.
- [7] D. Bogut, M., Đureš, A., Graho, Ž., Paljan, Tipsko ispitivanje buke niskopodnog elektromotornog vlaka, Automatizacija u prometu '11, 2011.
- [8] Rulebook 314 on maintenance of track and railway facilities, Croatian Railways
- [9] A. A. van Lier, The Measurement, analysis, and presentation of wheel and rail roughness, AEAT report NSTO/97/9571011/005, 1997.
- [10] P. Cordier, J.-F. Fodiman, Experimental characterisation of wheel and rail roughness, Proceedings of the Workshop Roughness Measurements in Utrecht, SNCF, 1999.
- [11] ANSI S1.11-1986 specification for third-octave band filtering
- [12] Harmonised Accurate and Reliable Methods for the EU Directive on the Assessment and Management of Environmental Noise (HARMONOISE). Definition of track influence: roughness in rolling noise., 2003.

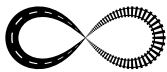

## LOW NOISE PAVEMENTS: AVAILABLE SOLUTIONS

Jean Paul Michaut  
Colas, France

### Abstract

For a long time, people complain about rolling noise. Since this time, the road pavement designers try to take into account the traffic noise level and mainly try to find solutions to decrease it. Knowing the complexity of noise is the first step that people have to know for finding the right solutions. Since the beginning of 80', Colas has worked on this field to find sustainable solutions. This presentation deals with some reminders about the rolling noise in order to understand the issue complexity then the different tools used for measuring this property. For this latter, it is reminded that noise measurement is not easy and we have to pay attention to the different used methods which can introduce some discrepancies when you compare the results and hence some difficulties. The history of the different low noise pavement is then illustrated by the beginning from the porous asphalt to the latest generation of asphalt concrete wearing course. One of the problems we have to solve is not only to decrease the noise but we also have to maintain high level of skid resistance. Some solutions are presented allowing gaining from 3 to 9 dB (A) in specific conditions in comparison with traditional wearing courses by keeping high level of skid resistance. Finally, it is concluded that from the point of view of road contractors, it is not possible to decrease more the rolling noise and that new solutions have to be found by the car or tyre manufacturers.

*Keywords: rolling noise, noise, pavement*

### 1 Introduction

For a long time, people complain about rolling noise. Since this time, the road pavement designers try to take into account the traffic noise level and mainly try to find solutions to decrease it. Knowing the complexity of noise is the first step that people have to know for finding the right solutions and that's why some reminders are presented below.

### 2 Noise reminders

Noise is a quick variation of atmospheric pressure in time. It's characterized by frequency and intensity and measured by acoustic pressure. The range level goes from 10 dB (A) which is absolute silence to 120 dB (A) for plane engine. When you are exposed to this level, you become deaf. Then you have to remember that acoustic pressure is the difference between atmospheric and sudden pressure and the noise level is a log function of acoustic pressure.

You may not forget that reflecting soil increases noise propagation, absorbing soil decreases noise propagation and that the noise addition is different. Just for illustrating it, here is an example:

$$60 \text{ dB (A)} + 60 \text{ dB (A)} = 63 \text{ dB (A)}$$

There are other properties for noise measurement such as mask effect, noise multiplication, wind and temperature which can affect the measured value. Sometime for assessing the noise in town, Equivalent Energizing Level is used.

### 3 Noise measurements

For rolling noise, numerous researches have been lead, firstly from the car manufacturer and then the tyre manufacturer and at last the road manufacturer. We now know that the rolling noise becomes dominant when the speed is greater than 50km/h and more. We don't come back on the different phenomenon causing the rolling noise, numerous documents have been issued concerning the physical and mechanical causes that generate noise from motors, the movement of mechanical parts and tire/pavement interaction.

For measuring it, there are different standards; some of them are European and other not. Among these methods there are statistical by pass method according to the ISO 11819-1 (Figure 1), close proximity method with different equipment (trailer or tyre car measurement) or laboratory measurement (Figure 2).



Figure 1 Statistical Bypass method



Figure 2 Close proximity method

Before speaking about rolling noise and its values, we have to keep in mind that noise depends on numerous factors such as: speed, temperature, wind, humidity, environment conditions (trees, safety barrier, etc.) and the measurement method. That's why we have to take care when we compare the values obtained to be sure to have the same test conditions.

## 4 How to decrease the rolling noise?

First of all, we can get some lesson out of the first observations from porous asphalt. This particular wearing course was developed to reduce the water spray and aquaplaning phenomenon due to rain and hence to improve the driver safety. At this time we observed rolling noise reduction. This improvement was mainly due to the high porosity (void content) in this layer.

The first lessons from Porous asphalt were:

- noise reduction round 3 dB(A) when compared to traditional asphalt concrete by statistical bypass method,
- clogging problem,
- small aggregates.

With these previous data, for the noise-reducing formulation, the mix design phase is extremely important, especially in terms of optimizing air void content in situ and verifying water content. Adsorption characteristics then come into play, and their evaluation is not part of current mix design practice and that's why some specific equipment for measuring noise in laboratory is necessary (Kundt tube for example).

Following the porous asphalt development and in order to improve the main properties double layer porous asphalt was developed. The main conclusions from this surface were:

- Double-layer porous asphalt reduces noise significantly as both engine and tyre/road noise is reduced by up to 6,5 dB in the year 0.
- The best and most durable solution was PA 8 as the top layer and DA16 or DA22 as the bottom layer. Here the noise-reduction effect was kept for 7 years (from 4,6 dB in the year 0 to 2,0 dB in the year 7)
- Cleaning with high-pressure water jetting once a year is needed
- The surface structure is sensitive to sideways forces from tyres on turning vehicles in crossings etc.
- It is relatively expensive compared to other wearing courses and requires a lot of planning and maintenance.

### 4.1 First generation

For having good rolling noise wearing course, one have to choose:

- small grading size,
- high void content,
- layer thickness, etc.

but by keeping for the surface characteristics a high level of skid resistance, a good durability, good mechanical performances such as rutting and shearing resistances.

According to this, specific wearing courses were developed for satisfying these points and we now find thin and ultra thin asphalt concrete, open grade asphalt concrete, stone mastic asphalt, etc. These formulations are mainly based on a open surface texture and small amount of connecting voids. Furthermore, European research (SILVIA project) was lead on rolling noise and the main findings were the following for avoiding noise from:

- air pumping: open surface texture,
- tyre vibration: very even surface, small maximum aggregate size,
- and elastic pavement.

According to these researches, the identity picture for this low rolling noise wearing course was to have the following properties:

- Thin or very thin asphalt concrete (from 2 to 4 cm thick),
- o/6 grading
- Modified binder

And the gain was around from 2 to 4 dB (A) at 90km/h and for a temperature of 20°C compared to a traditional asphalt concrete. That was the first generation of low rolling noise pavement.

#### 4.2 Second generation

Then the second generation is appeared by taking into account the last researches. The solution was also to use thin or very thin asphalt concrete but by optimizing or increasing the skid resistance and lowering the rolling noise as much as possible. As said before, the asphalt concrete formulation is essential and you have to choose aggregates with good intrinsic properties (shape and hardness), by increasing the number of contact points with tyre for decreasing the noise impact , by keeping good surface drainability by macro texture and finally, to increase the noise absorption by void content (small and winding voids).

One of the Colas products meets these requirements: it is called Rugosoft. The main properties for this special wearing course are:

- fine grading (from 6 to 8 mm according the available fraction sizes in European countries)
- continuous grading curve which is completely different from the previous solutions for which gaps graded grading curve were asked,
- with high proportion of small aggregates
- with modified binder
- with void content between 20 and 25%.

On the following Figure 3, the skid resistance has been measured and compared with very thin asphalt concrete.

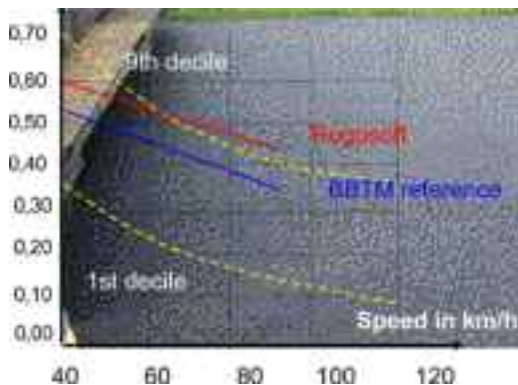

Figure 3 Skid resistance level – longitudinal braking force coefficient (PIARC tyre: RN 76 after 3 years)

With this kind of asphalt concrete the noise decrease is around 4 to 6 dB (A) at 90km/h and 20°C by using Statistical Bypass method. The noise performances are on the same level as double layer porous asphalt but it's a easier and cheaper technique.

#### 4.3 Third generation

For improving the previous performances, we decided to launch new research and we arrive at the third generation of low rolling noise pavement. For this research in the laboratory, we have used the Kundt tube. Due to these studies, we found the following conclusions:

- fine grading 0/4 mm,
- highly modified bitumen,
- an optimized grading curve for a maximum acoustic absorption.

This new product (Nanosoft) has good properties and also good skid resistance (Figure 4). According to the French data, this product has the lowest value obtained by the statistical by pass method (90km/h and 20°C) as we can see on Figure 5.



Figure 4 Nanosoft PMT : 0.7 to 0.8 mm

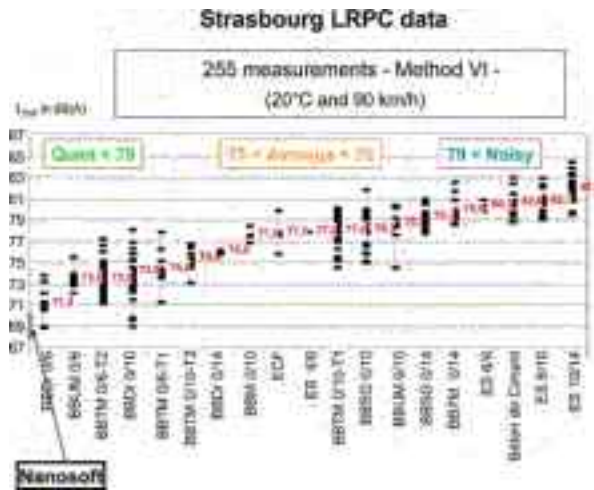

Figure 5 Nanosoft Noise measurement

## 5 Conclusions

With the different products developed, the gain for rolling noise can go down from 2 or 3 dB (A) with porous asphalt and the first generation of low noise asphalt concrete to 7 or 9 dB (A) for the third generation in comparison with traditional asphalt concrete wearing course. One other problem we have to keep in mind is not only to decrease the noise but we have to maintain high level of skid resistance. Solutions which have been presented also give a high level of skid resistance. From the research, we can conclude from the point of view of road contractors, that it is not possible to decrease more the rolling noise and that new solutions have to be found through the car or tyre manufacturers.





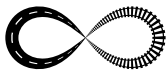

## INTEGRATED NOISE PROTECTION BARRIERS AND SOLAR POWER PLANT ON RIJEKA BYPASS

**Boris Huzjan, Sanjin–Velebit Pešut**  
*Rijeka–Zagreb Motorway, Croatia*

### Abstract

During the upgrade of the Rijeka Bypass to full profile 8.86 km long south carriageway from Orehovica to Diračje Interchange was built, starting at the beginning of 2008, and ending by the end of 2009. Since the Rijeka Bypass passes through the urban area, special attention was given to noise protection, resulting with the largest and the most complex noise protection project of its kind in the Republic of Croatia. As a result of complex requirements of noise protection in the vicinity of 5 high skyscrapers in the Rastočine area, an 352 meters long arch structure over the bypass south carriageway was constructed. Further the structure was designed in a way as to integrate a dual function: noise protection for the tenants, living in the four nearby skyscrapers, and electrical energy production.

*Keywords: Rijeka Bypass, noise protection, solar energy, environment, urban areas*

### 1 Introduction

Rijeka–Zagreb Motorway (Autocesta Rijeka–Zagreb d.d.) is the second largest motorway company in Croatia with 182 km of motorways and 13 toll plazas in service [Figure 1.]. Two plazas are an open toll system and the remaining 11 plazas form a closed toll system from Zagreb to Rijeka.

In August 2007, Rijeka–Zagreb Motorway has, according to the IV Contract on the Amendments to the Concession Agreement, extended its concession area. Within that extension it took over the operation of the bypass of the second largest city in Croatia, the City of Rijeka, along with the obligation to upgrade the bypass south carriageway from Orehovica to Diračje Interchange, 8.86 km long, so as to make the Rijeka Bypass one whole, with its full traffic function, according to the design. Construction of the south carriageway started at the beginning of 2008, and the works were completed by the end of 2009. Given that the Rijeka Bypass passes through the urban area, special attention was given to noise protection during construction works.



Figure 1 Concession area of Rijeka– Zagreb Motorway.

## 1.1 Noise protection

Considering numerous types of environmental pollution we are subjected to nowadays, noise pollution is seemingly of 'low' importance. But noise has direct and indirect effects to human beings damaging their health, causing fatigue and lowering working ability, disturbing understanding, concentration, rest and sleep. This is precisely the reason why 'noise' has become, with the local population living in the vicinity of the motorway, one of the priorities which is being solved through the program of constructing noise protection walls. Exact noise level and the application of adequate safety measures is determined by a calculation model or monitoring after opening the motorway to traffic, or acoustic monitoring. The inclination is that functional and aesthetic criteria are to be reconciled in solving noise protection issues.

## 1.2 Noise protection on Rijeka Bypass

Construction of noise protection walls on the Rijeka Bypass is the largest and the most complex project of its kind in the Republic of Croatia. It includes the section from the Katarina Tunnel exit until the end of the Diračje Interchange which is 7 km long. Noise protection wall on that section is constructed using various materials – concrete, aluminum and glass, and the total surface of walls amounts approximately to 50,000 m<sup>2</sup>, which currently makes this the largest project of its kind in the Republic of Croatia.

## 2 Integrated noise protection and solar system

### 2.1 Solar noise barrier

On the part of the section in the vicinity of the skyscrapers, in the Rastočine area, as a result of complex requirements of noise protection and the vicinity of 5 skyscrapers for the first time in Croatia an arch structure over the entire bypass south carriageway was constructed. Acoustic calculations have shown that it is practically impossible to protect the top floors of the skyscrapers using a standard, vertical sound barrier. As a possible solution, in preliminary acoustic design, a structure with a 5-meter high vertical wall and the inclined, cantilever extension 8.0 m long, was suggested. This solution is, from the building aspect, unfavorable, since the noise barriers also present the wind barriers, and the wind load onto these

is huge. Closed framed structure was than the best possible solution. Therefore a structure resembling a tunnel was chosen, 5.0 m high at its lowest point, and about 7 m high in the central axis, with a span of 10.50 m and length of 352 m [1]. This kind of a tunnel consists of a noise barrier towards the southern side, and is only partially enclosed on that side (5.0 m in width), thus protecting the inhabitants on the top floors of the skyscrapers, built next to the road, from noise. Special attention was given to this challenging part of the alignment, by the design engineers and the representatives of the City of Rijeka, in order to 'reconcile' the specific requirements of noise protection and aesthetic appearance of this part of the noise protection wall. Standard aluminum plates for noise reduction are placed on vertical planes of the 'tunnel', while the 'tunnel' roof is filled, to the half of its width, with solar modules. Noise protection from the north side of the motorway was constructed using aluminum plates for the vertical plane, while the inclined plane was filled with solar modules. Total length of the segment, where the solar noise protection wall is placed, is 352m.



Figure 2 Cross section – closed framed structure for noise protection.

## 2.2 System description

The system is made of 1232 solar modules type ENERGOBEREN 215W, which, with the steel frame, make a 352-meter long noise barrier. The noise barrier is in form of a tunnel above the bypass south carriageway, and it is closed only to the half of its width (Image 4). System has 30-grid connected inverters which transfer DC voltage (about 600 V) into AC synchronized three-phase voltage (400 V, 50Hz). The inverters are connected to the electricity substation 400 kVA with 400 V/10 kV which is built in cooperation with Elektroprimorje Rijeka (company for distribution of electricity) from Rijeka.

## 2.3 Module connection methods

The modules are placed in five rows above the south part, and in two rows above the north part of the motorway. There are four groups of inverters: A, B, C, D. Group A (identical to groups B, C and D). 42 solar modules connected in series are connected to each inverter. 21 solar modules connected in series are connected to each MPPT (maximum power point tracker). One inverter is connected to the modules situated in the same row. Each group of modules contains seven inverters, except for the group D which contains nine inverters.



Figure 3 View towards the solar noise protection wall from the south.



Figure 4 Constructed integral system – view from inside.

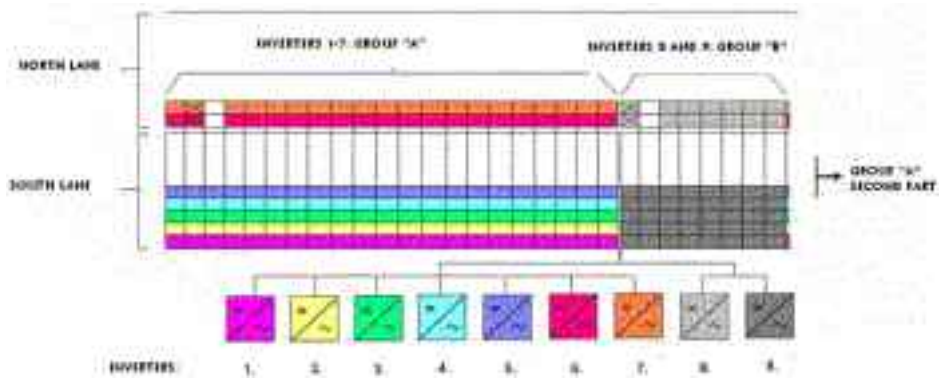

Figure 5 Connecting modules onto particular inverters of group A (first part) and group B.

### 3 Produced energy and cost-effectiveness

The price of this solar system is approximately 1,130,000.00 €. The amount of energy that would be produced in a period of one year, if there is no shadowing, is 287,869 kWh [2]. The amount of energy produced in a one year period, taking into account shadowing, is 205,548 kWh (or 71% of production without shadowing). The expected amount of energy to be produced by the system in a period of one year equals to 230,295 kWh. Deviation is +/- 5%.

### 4 Conclusion

In order to make use of the favorable position of panels in the noise protection system, which is designed in shape of an artificial tunnel, in the zone of skyscrapers on the Rijeka Bypass, the panels are made of solar collectors for electricity production, thus forming an integral system of noise protection and electrical energy production from renewable resources. Return on this investment is planned after 11 years.

Apart from protecting the nearby skyscrapers from noise, and the expected return on investment in the specified time period, this project also has the following effects:

- Aesthetical intervention improves the overall appearance of this part of Rijeka, which is, to a certain extent, affected by skyscrapers,
- Increase environmental awareness,
- Tourist promotion of the City of Rijeka and the Republic of Croatia.

### References

- [1] Damjanović, J.: Solar system within noise protection barriers on Rijeka bypass, Electrical project no. 35-09/G, Telecontrol d.o.o. Rijeka, 2009.
- [2] <http://re.jrc.ec.europa.eu/pvgis/apps/pvest.php?lang=en&map=europe>



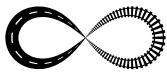

## ROAD TRAFFIC NOISE MODELING AT ROUNDABOUTS

Saša Ahac, Vesna Dragčević

*University of Zagreb, Faculty of Civil Engineering, Croatia*

### Abstract

It is well known that the specific dynamics of traffic at road intersections can greatly influence noise levels in urban and suburban areas. This is especially true when modeling noise at roundabouts, where temporal and spatial variations in vehicle kinematics can cause different noise levels than free-flow traffic on open road segments. Depending on the way noise prediction models account for traffic flow, these dynamic effects are more or less accurately captured. In this paper, a case study is presented, consisting of a road traffic noise level analysis in the vicinity of three suburban roundabouts in the City of Zagreb. Noise calculations were conducted by means of specialized noise prediction software using static and analytic noise models (modified RLS 90 and European interim method). Accuracy of the obtained noise contour maps was demonstrated by comparing the simulated and the observed noise levels at three receiver points along every roundabout. The aim of this research is to establish the level of reliability of applied noise models and to determine whether they can be used in road traffic noise prediction for suburban roundabouts in Croatia.

*Keywords: noise modeling, roundabout, traffic flow, calculation methods*

### 1 Introduction

Today road traffic noise is the main contributor to the excessive environmental noise levels in urban and suburban areas. Negative impact of traffic noise on residents is well known: it deteriorates human health, causing fatigue and reduced work capacity and also interferes with communication, concentration, relaxation and sleep. Practice has shown that due to the constant growth of population and associated increase in traffic loads, and despite the implementation of noise protection measures, overall noise levels in urban and suburban areas are increasing. Therefore, it is essential to systematically track changes in traffic noise levels and evaluate its impact on residents, which is possible by means of noise maps.

In the past two decades roundabouts became one of the most popular choices for intersections in suburban and urban areas adopted by town planners. According to the available data, in the year 2008 there were more than 130 roundabouts in Croatia, 85 of which were located in urban and suburban areas [1], and today there are over 30 modern roundabouts located in the City of Zagreb. Because of that, their influence on environmental noise levels should not be neglected. In this paper a case study is presented consisting of a road traffic noise level analysis in the vicinity of three roundabouts located in the suburban area of the City of Zagreb. Noise analysis included road traffic noise calculation by means of specialized software and two models used for road traffic noise prediction in Croatia: static German RLS 90 model (modified for the use in local traffic conditions) and analytic European interim model. In order to investigate accuracy of these models, calculated noise levels in the vicinity of analyzed roundabouts were compared with the noise levels measured in situ. The results of this study will help to establish the level of reliability of these noise models and to determine whether they can be used in road traffic noise prediction for suburban roundabouts in Croatia.



## 2 Road traffic noise modeling

The first step in the evaluation of traffic noise situation is the determination of noise levels and their presentation on noise maps. Methods used in the noise levels determination are: field measurements, calculations conducted by means of noise prediction software (noise modeling) and the combination of both measurements and calculation.

For the purpose of noise mapping, noise modeling is more suitable than field measurements. Measurements are very time consuming and can be carried out only under suitable weather conditions. Also, possible changes in future noise levels can only be determined by computer simulations. Production of a high quality computer model of the traffic noise emission and propagation is therefore a necessary prerequisite for prediction of road traffic impact on the noise situation.

### 2.1 Influence of intersections

The presence of an intersection results in the increase of noise levels in the surrounding area due to the change in the driving pattern of the vehicles, such as speed, acceleration or deceleration [2] – roundabouts are no exception. Temporal and spatial variations in vehicle kinematics at intersections can cause different noise levels than free-flow traffic on open road segments. Depending on the way noise prediction models account for traffic flow, these dynamic effects are more or less accurately captured.

In static noise models roads are divided into sections where traffic flow is considered smooth and homogeneous. When used in prediction of noise levels in the vicinity of an intersection these noise models usually include a propagation correction term, the value of which depends on the distance to the intersection. The influence of intersections on noise levels in the RLS 90 model can be included by a propagation correction term for intersections with traffic lights, for up to a distance of 100 m from the intersection [3].

Analytic noise models attempt to capture the impact of interrupted traffic on the average vehicle speed profile. They split each road section into subsections where vehicles are assumed to have a constant average speed and homogeneous traffic flow conditions [4]. With the European interim noise prediction model the influence of the intersection can be defined based on the decrease or increase of speed in relation to the mean traffic speed of the road. The type of traffic flow can be assumed as pulsated decelerated (upstream of the intersection) or pulsated accelerated (downstream of the intersection) [5].

Problems that emerge while modeling noise at roundabouts relate primarily to capturing the impact of their specific traffic flow conditions: minimized start-stop operations and queuing, smaller average speed of approaching and passing traffic with regard to signalized intersections. Methods presented in this paper are commonly used in Croatia for noise calculations on open road segments and signalized intersections, modified for application on roundabouts.

### 2.2 Location description and field measurements

Roundabouts presented in this paper are located on the edges of the fast growing suburban area on the west side of the City of Zagreb (Figure 1). In the immediate vicinity of the observed intersections residential and commercial facilities (shopping complex and a sports hall) are situated. Surrounding residential buildings are five to eight storeys high, while the height of nearby commercial facilities is approximately 20 m. In Table 1 basic geometric and design elements of analysed roundabouts are presented.



**Figure 1** Location of analysed roundabouts.

In order to investigate the accuracy of analyzed noise models short-term (15 minutes) noise level measurements were done by three precise sound level meters at each roundabout at favourable meteorological conditions and height of 1,2 m above the ground surface. Measuring posts at each roundabout were placed at the distance of 7,5 m from the axis of the lateral lane at entry and exit lanes and next to the circulatory roadway (Figure 2). On each measuring post the measurements were repeated 3 times in the period 'day'. Results of these field measurements are shown in Figure 4. Traffic load for each road lane was determined by video recording of the traffic. This measurement has been done simultaneously with the noise measurement. Vehicles were divided in two groups: light and heavy vehicles. Traffic flow during field measurements was continuous; measurements during peak hour traffic were avoided because of possible traffic congestions.

**Table 1** Basic geometric and design elements of analysed roundabouts.

Roundabout	Inscribed circle radius	Approach legs	Circulatory roadway width	Number of lanes on circulatory roadway
R1	32 m	2 two-lane; 1 single-lane	13,5 m	2
R2	23 m	3 two-lane	11 m	1
R3	25 m	4 two-lane	10 m	1

Data on the remaining noise emission parameters (road surface type, the longitudinal slope of road, vehicle speed, condition of traffic flow) and noise propagation parameters (relief, ground surface type, barrier and building height) for both noise models was collected during the reconnaissance of the area and then incorporated with digital 3D terrain model derived from available digital maps of the area (orthophoto and Urbanistic Master Plan of City of Zagreb).



**Figure 2** Location of measuring posts.

## 2.3 Noise models

When modeling traffic at roundabouts a spatial approach was used, in which lanes of intersection were divided into segments with different traffic flow conditions: constant speed, stop and go, deceleration, and acceleration (Figure 3). On each segment average speed of vehicle movement was determined by measuring the time of vehicle passage on the known length of road segment (it was presupposed that vehicles move at uniform speed). These values were applied in both noise prediction models. Additionally, in order to simplify the calculation procedure, in both models position of noise sources on circulatory roadway was assumed to be above carriageway axis. In order to adjust the traditional RLS 90 model to the local traffic conditions, following modifications were made: source of the traffic noise was situated at 0,5 m above the road surface for each axis of each individual lane on the roundabout legs, measured traffic load was divided equally over lanes and heavy vehicles were defined as vehicles with a total weight of 3,5 tons.

In the modified RLS 90 model different traffic flows were defined by the average speed observed on each segment. Influence of queuing and stopping of the vehicles on the approach legs of the roundabout was defined by introducing traffic light position on each stopline and entrance on the circulatory roadway. In the European interim noise prediction model influence of the intersection was defined by introducing the observed average speed and the type of traffic flow on each road segment (ie constant, stop and go, accelerated pulsated and decelerated pulsated flow).

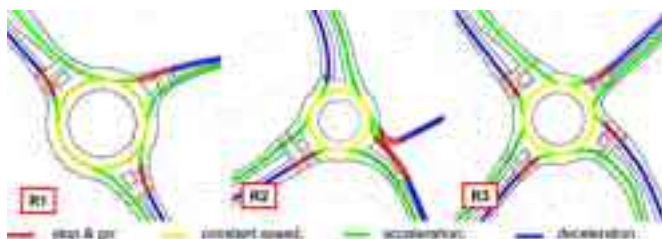

Figure 3 Segments with different traffic flow conditions and average speed.

## 2.4 Noise prediction results and model verification

The calculation of equivalent noise levels for the period 'day' was conducted by means of specialised noise prediction software LimA at the height of 1,2 m (due to the comparison to field measurement results) using modified RLS 90 model and European interim model. Results of these calculations are shown in Figures 4. and 5. The validity of the noise calculation model is determined by comparing the results of calculations and field noise measurements in corresponding measuring posts.

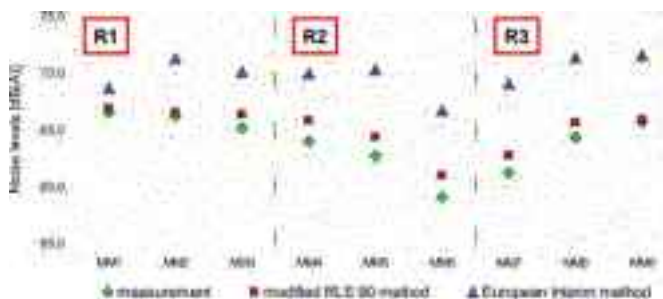

Figure 4 Measured and calculated noise levels in measuring posts.

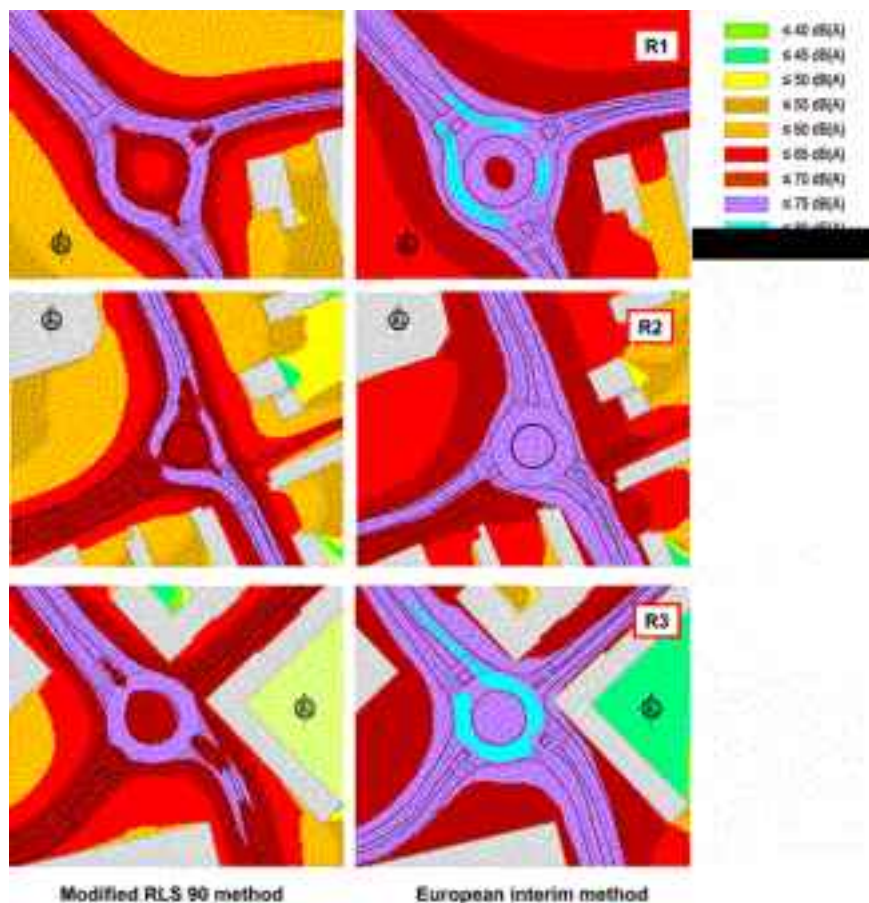

Figure 5 Predicted equivalent road traffic noise levels for the period 'day'.

Although the same input parameters for noise prediction were used in analysed models (such as traffic load, road surface type, the longitudinal slope of road, vehicle speed and type, etc.) substantial differences in the calculation results occurred, as shown in Figure 5. This departure can be explained by differences in noise emission and propagation modeling, ie differences in noise emission values for light and heavy vehicles (which are notable at lower speeds), differences in the assumptions concerning the road surface type, the longitudinal slope of road, meteorological conditions, modeling of the ground effect, interaction between the ground effect and screening [6, 7]. Also, studies have shown that increased complexity of model that includes more physical phenomena and effects, such as the impact of interrupted traffic on the average vehicle speed profile in analytic European interim model, will not automatically produce better results in terms of model accuracy [7].

Highest deviation from measured noise levels were recorded on the measurement posts at roundabout R2, and they stood at 2 dB(A). Meanwhile, the deviations of European interim model calculations results were significantly higher, reaching from 2 dB(A) on roundabout R1 to 8 dB(A) on roundabout R3. These results correspond to the results of previous studies conducted at the Department of Transportation on Faculty of Civil Engineering which included comparison of the calculated traffic noise levels for open road segments and signalized intersections [8, 9, 10]. Finally, all the calculated values were higher than the measured ones, which is favorable in terms of noise protection.

### 3 Conclusion

Roundabouts became very popular solutions for urban and suburban intersections. Problems that emerge while modeling road traffic noise in their vicinity prompted the investigation of the applicability of road traffic noise prediction models used in Croatia for noise calculations on roundabouts. These models are the static RLS 90 model (modified for the use in local conditions) and the analytic European interim model, which are intended primarily for calculation of road traffic noise on open road segments and signalized intersections. The RLS 90 model is often applied in noise calculations in practice because of its simplicity and tradition of use, while the European interim model is prescribed for noise calculations by the Regulations [11] for the purpose strategic noise mapping.

Analysis results showed that both models resulted in noise levels that were higher than measured ones (which is favorable in terms of noise protection), and that the results of modified RLS 90 model were closer to the measured noise levels. Therefore it can be concluded that modified RLS 90 model could be more suitable for noise prediction on roundabouts than European interim model. Although both methods provided the satisfying results in terms of noise protection, the question arises whether the use of complex interim method is justified in e.g. noise abatement projects. Since the analysis was conducted on a small number of examined cases, further investigations are needed in order to define the usability of both methods for the purpose of road traffic noise prediction in the vicinity of suburban roundabouts in Croatia.

### References

- [1] Legac, I., Pilko, H. & Šubić, N.: Introduction on roundabouts in Croatia - preliminary experiences, 16th IIRF World Congress, Lisboa, 2010.
- [2] Quartieri, J., Mastorakis, N.E., Guarnaccia, C., Troisi, A., D'Ambrosio, S. & Iannone, G.: Traffic Noise Impact in Road Intersections, INTERNATIONAL JOURNAL OF ENERGY AND ENVIRONMENT, Issue 1, Volume 4, 2010.
- [3] RLS 90, Richtlinien für den Lärmschutz an Strassen, VD Nr. B6510 Ver: 03/2002. Der Bundesminister für Verkehr, Abteilung Strassenbau, 2002.
- [4] Chevallier, E., Can, A., Nadji, M. & Leclercq, L.: Improving noise assessment at intersections by modeling traffic dynamics, Transportation Research Part D 14, pp. 100–110, 2009.
- [5] Lang, J. et al.: AR-INTERIM-CM, Adaptation and revision of the interim noise computation methods for the purpose of strategic noise mapping, WP 3.1.3: Road traffic noise – Description of the calculation method, European Commission, DG Environment, 2002.
- [6] van Leeuwen, J.J.A.: Comparison of prediction models for road traffic noise, Report I.97.0949, TU Delft, 1997.
- [7] Probst, W.: Accuracy and precision of prediction models for road noise, EURONOISE 2009, Edinburgh, 2009.
- [8] Dragčević, V., Ahac, S. & Stančerić, I.: Experience in estimation of road traffic noise situation in urban zone, the 16th International Congress on Sound & Vibration, Recent Developments in Acoustics, Noise and Vibration, Krakow, 2009.
- [9] Dragčević, V. & Ahac, S.: Towards to optimisation of road traffic noise protection design (Chapter), Prometnice - Nove tehnologije i materijali, ed. Lakušić, S., University of Zagreb, Faculty of Civil Engineering, Department for Transportation, Zagreb, pp. 177-216, 2010.
- [10] Ahac, S., Dragčević, V. & Ecmović, A.: Road traffic noise abatement - the case of State Road D31, Forum Acusticum 2011, Aalborg, 2011.
- [11] Regulation on the noise mapping and content of noise maps and action plans and the calculation of permitted noise indicators, Official Journal, NN 75/2009.



## MODELLING THE IMPACT OF TRAFFIC ON QUALITY OF LIFE: SCENARIO EVALUATION FOR THE CITY OF GHENT

Dominique Gillis<sup>1</sup>, Dirk Lauwers<sup>1</sup>, Luc Dekoninck<sup>2</sup>, Dick Botteldooren<sup>2</sup>

*1 Dept. Mobility and Spatial Planning, Ghent University, Belgium*

*2 Acoustics Group, Dept. Information Technology, Ghent University, Belgium*

### Abstract

Traffic influences the people's quality of life in various ways, both in a positive as in a negative sense. Traffic is inevitable in order to guarantee people's accessibility to various types of functions. On the other hand, traffic noise, traffic emissions, road safety, threatens people health and well-being. Because quality of life is more and more under pressure, because of the increasing traffic flow, traffic livability has become a key issue in nowadays' (Flemish) traffic planning.

Therefore, it is remarkable that little research has been done about assessing the total impact of traffic on the quality of life of the surrounding areas. Methods that are currently commonly used in Flanders have some important restrictions; the most crucial one is that the impact of traffic is considered to be very local. This is remarkable because people's quality of life depends on the whole living environment, covering a wider area.

For this reason, a project was set up by the Flemish Policy Research Centre Mobility & Public Works in order to develop a model to give a better representation of the impact of traffic on quality of life. The main focus was to achieve a better simulation of people's exposure to different types of traffic impacts by including not only the exposure at the home address, but also the impacts during activities at other locations and the impacts during trips.

*Keywords: urban traffic, livability, quality of life, travel behaviour, traffic noise, traffic emissions*

### 1 Introduction

Within the frame of the Flemish Policy Research Centre Mobility & Public Works a model was developed, aiming at a better assessment of people's perception of traffic annoyance in their living environment. The reason is that existing methodologies show intuitive shortcomings: for example most indicators are related to the road characteristics and traffic data (and not to people's exposure and perception) and only traffic impacts on the home location are taken into consideration (and not in the rest of their living environment).

Therefore, the main focus in the proposed methodology is to achieve a better simulation of people's exposure to different types of traffic impacts, in order to measure not only the exposure to traffic annoyance at the home address, but also the impacts during activities at other locations and the impacts during trips. This is achieved by simulating the individual activity patterns of the population within the study area. By evaluating each individual's exposure to different types of traffic impacts during his trips and activities (both at home and at other locations), a better representation of people's quality of life can be expected.

In different phases of the project, first a theoretical model has been developed for measuring the impact of traffic on living quality. In the second phase this theoretical methodology was

implemented in a model application, which was finally applied to a case–study for the city of Ghent. The model's possibilities were shown in a number of practical applications. This paper describes the results of some scenario evaluations, illustrating the impact of traffic behaviour on people's perception of the traffic impact.

## 2 Model description

### 2.1 Selection of an indicator set for 'traffic livability'

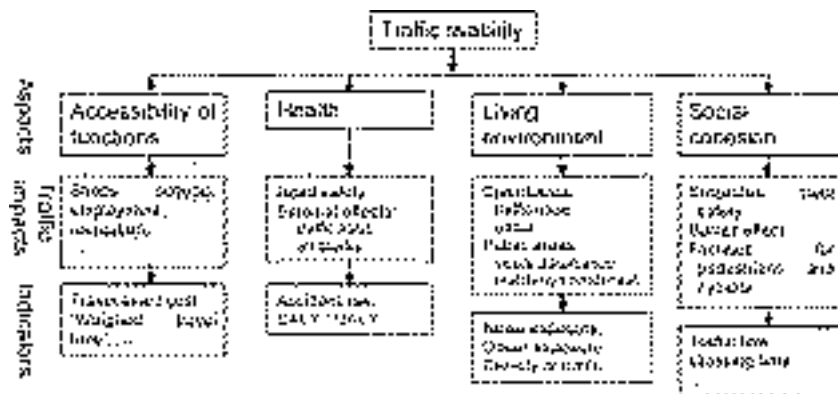

Figure 1 Definition of traffic livability, containing several types of traffic impacts, each with their own indicators

Existing methods split down the 'traffic livability' into separate types of traffic impacts, and define a set of indicators for each of them. The proposed model will follow the same structure, with a similar set of indicators. The main innovation is that indicators are chosen in order to reflect people's perception of traffic annoyance, rather than pure traffic data or road characteristics. For example, the quality of bicycle infrastructure is not indicated by width, but by a score indicating how well the infrastructure meets the design criteria.

The indicator set is based on a literature review concerning 'traffic livability', and related terms like 'quality of life' or 'living quality'. This resulted in a breakdown of the term into four components: accessibility of basic functions, health impact (as traffic emissions, sleep disturbance, etc.), effects on environment (noise annoyance, visual impact, etc.) and effects on the social functioning of the neighbourhood (barrier effect, etc.). Each component is divided into some partial effects with their specific indicators. Measuring traffic livability will be realized by measuring these indicators and aggregating them to a global score for each component and for the total traffic livability.

### 2.2 Methodology for the evaluation of the indicators

The main shortcoming of the existing methodologies for measuring the traffic livability is the (over-) simplified way of evaluating the indicators. The living quality of an address is considered to be determined by the traffic impacts at this very specific location: the local noise level, local air quality, etc, as if making a simple overlay of several layers.

In order to reach a better representation of the neighbourhood perception, an alternative methodology was developed, with the following characteristics:

- Traffic livability is measured by means of a broad set of indicators, representing different types of traffic impacts (accessibility, traffic noise, traffic emissions, etc.).
- The evaluation is not done for an average person, but takes into account individual needs and travel patterns, sampled from the Flemish large-scale trip survey (The Flemish Trip Be-

haviour Survey – Onderzoek VerplaatsingsGedrag, ovg), a large scale survey collecting trip data by means of trip diaries covering the whole of Flanders. The survey data consists of three data sets containing the family characteristics, the person's characteristics and the personal trip data. The survey has been executed in 1994–1995 (OVG-1), in 2000–2001 (OVG-2) and in 2007–2008 (OVG-3) (Ministerie van de Vlaamse Gemeenschap, 1996, 2004, 2009), each covering about 8.000 persons. This means that personal characteristics (age, marital status, professional activities, etc.) and family characteristics (number and age of children, car availability, etc.) and the consequent diverse mobility needs, are incorporated in the evaluation.

- The methodology reflects the daily activity pattern and the trip pattern. Beside the traffic impacts at home, also the effects during the trips and at the destinations are included in the evaluation. This means that the evaluation of traffic livability covers the complete living neighbourhood, rather than limiting it to the dwelling itself or the street it is located in.

These characteristics are reached with a Monte Carlo simulation method of, sampling random families and/or persons from the Trip Database of the Flemish Trip Behaviour Survey, and consequently sampling a logical destination from a set of pinpoint locations. The traffic livability of a dwelling location is then evaluated in the following steps:

- First of all, a random household is sampled from the Trip Database of the Flemish Trip Behaviour Survey. In the database a large set of characteristics are available about the household (composition, car availability, etc.) and its members (age, income, etc.) and their specific daily trips (number, purpose, distance, etc.).
- For all the trips that are reported by this household, the following step is to select a logical destination. This destination is again sampled from a database of possible destinations per trip purpose. For school trips a nearby school is selected, for shopping trips a shop, etc.
- For the collected trips, travel modes and destinations, the third step is to calculate a logical route from the dwelling to the destination.
- Knowing the dwelling location, destination locations, routes and transportation modes of all the trips and activities of each household member, it is possible to make the evaluation of this person's perception of the traffic impacts at home, during the trips, and at the destinations.

By sampling a sufficient number of dwellings per street segment (or a sufficient number of households per dwelling), this method results in an aggregated perception of traffic livability, representing a realistic variety of activity patterns and transportation needs and covering the complete living space of the population, rather than just the dwelling location. The expectation is that this will better reflect people's perception, as stated in surveys or interviews.

### 2.3 Global model structure

The sampling of households and their activity and trip pattern is only a part –albeit the most innovative part– of a larger model structure, which is represented in the following scheme. As indicated, the model consists of four major parts:

- the input GIS layers and databases, containing attributes about the infrastructure, traffic, dwellings, points of interest, and demographic statistics about trip behaviour and time usage;
- the exposure simulation, containing the simulation of individual activity and trip patterns, and the resulting exposure to traffic impacts (noise, air pollution, traffic safety risks, etc.);
- the traffic model, generating the overall traffic flows and traffic characteristics (such as traffic speed and congestion), which are used to derive traffic noise immissions and air pollution maps, evaluate safety risks, etc;
- the indicator aggregation module, where the results from the individual indicator evaluations are aggregated geographically (grouping individuals to a street or neighbourhood level) and/or thematically (grouping indicators to a thematic score and a global livability score).



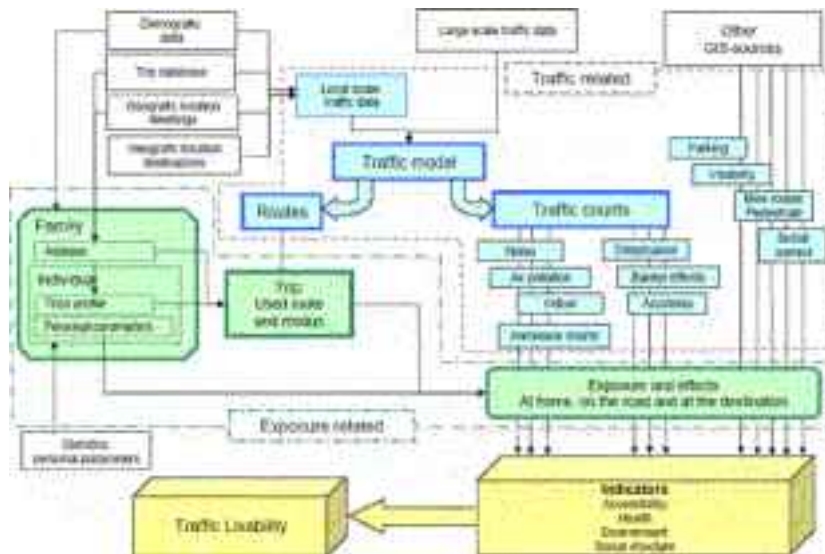

Figure 2 Global structure of the traffic livability model

### 3 Basic model applications

#### 3.1 Traffic livability maps

The presented model has been applied in a case-study for the Belgian city of Ghent. This case-study illustrates some of the model's possibilities. The most obvious application is the evaluation of the current traffic livability. Several statistics can be used to measure the quality (the average traffic livability evaluation, but also percentile values representing the better or poorer individual appreciations, etc.). Histograms can be used showing the distribution of the population's scores, or maps showing the geographic spread of the scores.

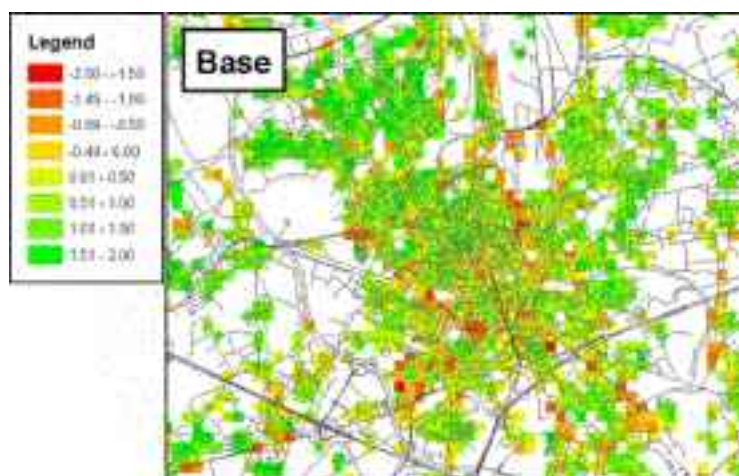

Figure 3 Model plot showing the average traffic livability using a zoom raster aggregation

Calculations for the current livability of the traffic in Ghent have shown realistic results. In geographic sense, problem areas are detected corresponding to the real problem areas, as reported in policy documents, but also reported appreciation, based on a large-scale survey about people's satisfaction with their living environment ('Schriftelijk Leefomgevingsonderzoek') is reproduced in a satisfying way.

Apart from the global score, the model also has further explanatory value, as further detail is available about the separate indicators. The model does not only show areas with good or bad traffic quality, but also explains why specific areas have better or poorer evaluations. In terms of transportation policy, the model does not only show the problem areas, but also enables further analysis on the type of measures that is needed (aiming at improved traffic safety, traffic noise, etc.).

### 3.2 Scenarios on traffic behaviour

Based on the model of the current situation, derived scenario's can be evaluated. This means that the traffic livability is recalculated, taking into account some modifications to the model input. These modifications can deal with the urban structure, the transportation network and the traffic behaviour (or a combination of these three).

Changes in the urban structure lead to a different spread of home locations and of functions in the neighbourhood. In the model this leads to a different evaluation of traffic livability, as people may change their destination choice if they can choose from more or less possible functions. Practical applications are for example the livability evaluation in new housing areas (how will inhabitants perceive the traffic annoyance in their neighbourhood?) or the impact of new shopping areas (e.g. a situation with an increase of more small-scale local shops, opposed to a situation with a limited number of large supermarkets).

Modifications to the transportation network may include the addition or removal of roads for specific travel modes (leading to more or less dense networks) or adapted speed limits. These measures influence people's mode choice and route choice, which again has a double effect: it changes their exposure to external traffic impacts, but also their own traffic emissions to the environment. For example, a modal shift from car to bicycle has the positive effect of eliminating a car trip and the resulting traffic noise, emissions, traffic unsafety, etc. But a second positive effect is that route choice by bike rather follows the shortest route (opposed to following the fastest route by car), and therefore uses a more quiet road with lower exposure to traffic noise, traffic emissions, etc.

At this moment, changes of the traffic behaviour are incorporated only in an indirect way, as the model is now based on a simulation of the reported activity patterns and the reported trip behaviour. Therefore, the methodology focuses on correct reproduction of reported behaviour. Changes to the behaviour are only possible by modifying the database of reported behaviour, for example by modifying the number of trips (for specific modes of purposes) or by changing the reported mode choice for certain trips.

Results of several scenario evaluations can be found in [4] and [7].

## 4 Conclusions

The proposed model has already been applied in several applications, both for analysing the current situation, as for the scenario evaluation. The results show a good reproduction of the real (reported) satisfaction about (the traffic impact on) people's living environment. Also scenario results show intuitively correct effects on the traffic impacts. This is mainly true for scenarios with relatively modest adaptations in regard to the current situation. However, in case of more radical scenarios, some of the limitations of the current model become clear. The most crucial limitations are:

- For a large number of indicators, external maps are imported as base data, for example air quality maps by the Flemish government are used. In radical scenarios, the radically changed travel behaviour (e.g. modal shift from car to other modes) results in changed exposure, which is fully incorporated in the model. However, there is secondary effect, as this modal shift results in lower traffic intensities, and thus in lower traffic emissions. Including this secondary effect in the model would require a recalculation (re-iteration) of the initial air quality map, based on the decreased traffic flows.
- In chapter 3.2 the possible contents of scenarios are described as three independent types of modifications (urban structure, transport network, travel behaviour). However, in case of thorough changes to the urban structure or to the transport network, the impact may result in an adaptation of people's travel behaviour: a reduced (or improved) accessibility may lead to a decreased (or increased) mobility. At this moment, this link is not included in the model, as travel behaviour is considered to be an independent input.

These limitations define the future challenges for further development of the model:

- The recalculation of the basic input maps is not a technical issue, as specific software for modelling traffic impacts (noise, emissions, etc.) is available. Coupling our model with external models would be a technical solution, although the procedure for evaluation of a scenario would be cumbersome if several external models need to run to produce the inputs for the traffic livability model. Therefore, more straightforward alternatives are required.
- The current model is strongly based on a simulation of the reported behaviour. In case of a more radical scenario, which influences the individual travel behaviour (either trip generation, mode choice, destination choice, etc.), one would want the model to automatically incorporate these changes. Therefore the inclusion of an individual travel choice model would be a major asset, estimating the impact of changing accessibility on the individual trip behaviour.

Especially this second challenge will be the subject of further elaboration of the model.

## References

- [1] Dominique Gillis, Dirk Lauwers, Dick Botteldooren, Luc Dekoninck, 'The assessment of traffic livability, including local effects at home, during trips and at the destination, based on the individual activity pattern and trip behaviour', Real Corp 2010, Vienna
- [2] Botteldooren D., Dekoninck, L.; Gillis, D., Dirk Lauwers 'The influence of trip behavior on assessment of the quality of the living environment' , ABAV Conference 2010, Ghent
- [3] Luc Dekoninck, Dominique Gillis, Dick Botteldooren, Dirk Lauwers 'Indicatoren voor verkeersleefbaarheid: uitwerking en toepassing van een model voor het meten van verkeersleefbaarheid', april 2011
- [4] Luc Dekoninck, Dominique Gillis, Dick Botteldooren, Dirk Lauwers 'Indicatoren voor verkeersleefbaarheid: toepassing van een model voor het meten van verkeersleefbaarheid aan de hand van een aantal case-studies', februari 2012
- [5] Botteldooren, D.; Dekoninck, L.; Gillis, D. 'Perceived quality of the living environment and noise', ICBen 2011, 11th International Congress on Noise as a Public Health Problem
- [6] Botteldooren, D.; Dekoninck, L.; Gillis, D. 'The Influence of Traffic Noise on Appreciation of the Living Quality of a Neighborhood', Int. J. Environ. Res. Public Health 2011, 8, 777-798
- [7] Dominique Gillis, Luc Dekoninck, Dirk Lauwers, Dick Botteldooren, 'Modelling the impact of traffic on quality of life: results from a case-study for the city of Ghent', BIVEC Transport research day 2011

## 13 GEOTECHNICS





## AN ALTERNATIVE ANALYSIS FOR DEVELOPING THE SWELLING MODEL FOR EXPANSIVE CLAYS

**Moshe Livneh**

*Faculty of Civil and Environmental Engineering,  
Technion–Israel Institute of Technology, Israel*

### Abstract

Pavements and railway beds are badly affected by the behavior of their expansive clay subgrades. Seasonal drying and wetting are particularly responsible for irregularities in the pavement surfaces through differential settlement and heaving. In Israel, a method of quantifying the amount of heave expected is based on one-dimensional laboratory swelling curves. Since time, site, and budget limitations frequently do not allow complete laboratory testing, empirical correlations are commonly used instead of the one-dimensional laboratory curves. In local studies conducted in 1969 and 1985, these correlations yielded the required general swelling model for any given clay characteristics. This general swelling model has recently been updated by applying the Excel-solver analysis to new local test results from, all together, 897 undisturbed specimens. The present paper, in addition to further updating the model, describes an alternative analysis carried out on these local test results. This alternative analysis is based on the following two-stage operation: (a) conducting a multiple linear regression on the swelling–pressure tests results (i.e., the ASTM 4546 Method c test results) to obtain the swelling–pressure correlation for any given clay characteristics; (b) utilizing the correlative equation obtained in stage a to perform an additional linear regression on the swelling–percentage test results (i.e., the ASTM 4546 Method B test results) with a single independent variable, defined by the given surcharge pressure divided by the predicted value of the swelling–pressure.. Finally a comparison of these two general swelling models indicates a preference for the existing model, generated from the Excel-solver analysis.

*Keywords: Excel-solver, expansive clay, heave, swelling model,  
swelling percentage, swelling pressure*

### 1 Introduction

Expansive soils are a worldwide problem that poses several challenges for civil engineers. Pavements and railway beds constructed on these clays are subjected to large uplift forces caused by swelling generated from moisture variation. These uplift forces induce heaving and cracklings to the surface of these structures as shown in Figure 1.

Researchers and engineers have for several years been occupied with the engineering problems presented by swelling clays. The research and the experience that developed, which have found expression in many technical publications, in effect highlight basic differences among the approaches practiced in various countries, whether Australia, India, Israel, Nigeria, South Africa, USA (Texas, Kansas, etc.), Turkey, and others, in particular with regard to clay as a subgrade material for flexible pavements. Consequently, these various approaches should be considered and adjusted to local needs.



**Figure 1** Severe longitudinal cracking and differential settlement and heaving taking place on the surface of a pavement based on an expansive clayey subgrade

In Israel, theoretical and practical engineering experience has accumulated on the construction of such pavements since 1956. The initial basic research, together with the knowledge of the performance of numerous pavements that accrued, led to the crystallization and adoption of engineering solutions for the construction of pavements on these soils; see, for example, [1–5]. In other words, these activities yielded a local procedure for designing flexible pavements on swelling clays. This procedure has been suggested for inclusion in the Israeli PWD guide for the design of flexible-pavement structures.

Predicting the heave of a pavement surface as a result of subgrade swelling constitutes a basic feature of the Israeli procedure. The prediction necessitates knowledge of the swelling-pressure characteristic (curves) of the clay strata under consideration, which is usually obtained from laboratory tests on undisturbed clay specimens. These swelling curves are dependent on knowledge of the following parameters that characterize the clay being studied: (a) its liquid limit, (b) the ratio between its in-situ moisture content and its plasticity limit, and (c) its in-situ dry density.

Previous discussions indicate that the development of the local swelling model is very important for calculating both heave and adequate surcharge pressure. The latest local swelling model was developed in 2011 [6 and 7] on the basis of 352 local test-results. Since then, 545 new test results have become available, enabling an updating of the swelling model. In light of all the above, the objectives of this paper are as follows:

- updating the swelling model published in 2011 [6 and 7] to predict vertical swell under a given vertical pressure exerted on the clay under consideration;
- developing an alternative swelling model following the local computational procedures published in 1985 [3];
- comparing the two adjusted swelling models and selecting one for the final routine calculations.

The sections to follow will detail the process of attaining these three objectives and their associated conclusions. Finally, the following quotation from the song by George and Ira Gershwin seems appropriate here: '...In time the Rockies may crumble, Gibraltar may tumble, there're only made of clay, but our love is here to stay....'

## 2 Review of the existing model

In [2 and 3], 352 undisturbed samples were used to determine the direct dependence of vertical swelling, in percentages, with the following variables that characterize undisturbed clay samples: liquid limit (LL) in percentage, moisture content (w) in percentage, dry density in  $\text{kN/m}^3$ , and finally the applied vertical pressure (Pp) in kPa. This determination was performed with the Excel–Solver command, utilizing (a) the first Israeli general swelling–pressure model arrived at in [2], since the linear multiple regression was conducted on 125 undisturbed samples in 1969; and (b) the basic vertical swelling model arrived at in [3] after a series of empirical relationships reported in the technical literature was analyzed in 1985 but no requested verification was received from local laboratory tests.

In the studies of [6 and 7], two replacements were utilized in order to obtain a higher coefficient of determination ( $R^2$ ):  $\log(\text{LL})$  instead of LL and  $W/\text{PL}$  instead of w. This led to the two following equations:

$$\log(\text{Po} / 98.07) = -3.256 + 1.540 \times \log(\text{LL}) - 0.537 \times W / \text{PL} + 0.738 \times (D / 9.81) \quad (1)$$

$$\text{Sp} = -1.872 \times (\text{Po} / 98.07) \times \log(\text{Pp} / \text{Po}) \quad (2)$$

The standard error (SE) value associated with the development of these two equations is 1.45%, and the coefficient of determination ( $R^2$ ) obtained for them is rather low, 0.387. This value, however, is at the same order of magnitude as that obtained for the multiple regression analysis performed on 514 undisturbed samples in Kansas (i.e., 0.35 [8]). Here it should be noted that the advantage of eqn (2) over the original equation of [3] is that in contrast to the original equation, eqn (2) is based on a statistical analysis of the local test–results.

The significance of the SE value of 1.45% is that 68% of the total vertical swelling predictions from eqns (1) and (2) are expected to be accurate within a range of  $\pm 1.45\%$  of the values calculated. Similarly, 95% of these total predictions are expected to be accurate within a range of  $\pm 2.90\%$  of the calculated values. Both these ranges indicate the existence of an extensive dispersion characteristic in the measurement results.

## 3 Development of the updated models

The previous 352 test results and the new 545 test results (i.e., 897 test results in all) became available for updating the swelling model with the Excel–Solver command. This updating led to the following two equations:

$$\log(\text{Po} / 98.07) = -4.234 + 2.110 \times \log(\text{LL}) - 0.399 \times W / \text{PL} + 0.604 \times (D / 9.81) \quad (3)$$

$$\text{Sp} = -2.191 \times (\text{Po} / 98.07) \times \log(\text{Pp} / \text{Po}) \quad (4)$$

The standard error (SE) value associated with the development of these two equations is 1.952%, and the coefficient of determination ( $R^2$ ) obtained for them is higher than that (0.604) associated with eqns (1) and (2).

Figure 2 summarizes the overall prediction accuracy of the swelling model given by eqns (3) and (4). A measure of overall bias in this model relates to how closely the unconstrained linear regression line of predicted versus measured vertical swelling matches the line of equality; i.e., how close are the unconstrained intercept and the slope to 0 and 1, respectively.

Thus, Figure 2 indicates that the unconstrained regression line has an almost considerable intercept ( $\text{Sp}=0.787\%$ ) and a slope lower than the value of 1 (0.596), thus, exhibiting an almost considerable bias and, on the average, poor similarity between measured and predicted values.



In addition to the above updating of the model, an alternative analysis was carried out on the 897 local test results. This alternative analysis is based on the following double-stage operation: (a) conducting a multiple linear regression on the swelling–pressure test results (i.e., the ASTM 4546 Method C test results) to obtain the swelling–pressure correlation for any of the given clay characteristics listed above; (b) performing an additional linear regression on the swelling–percentage test results (i.e., the ASTM 4546 Method B test results) with a single independent variable, defined by the given surcharge pressure divided by the predicted value of the swelling–pressure and utilizing the correlative equation obtained in the previous stage. The first stage, described above, was carried out on 362 of the total 897 undisturbed samples. Obviously for these undisturbed samples, the vertical swelling was kept at zero. This led to the swelling–pressure model given by the following equation:

$$\log(P_o/98.07) = -6.382 + 2.619 \times \log(LL) - 0.226 \times W/PL + 1.161 \times (D/9.81) \quad (5)$$

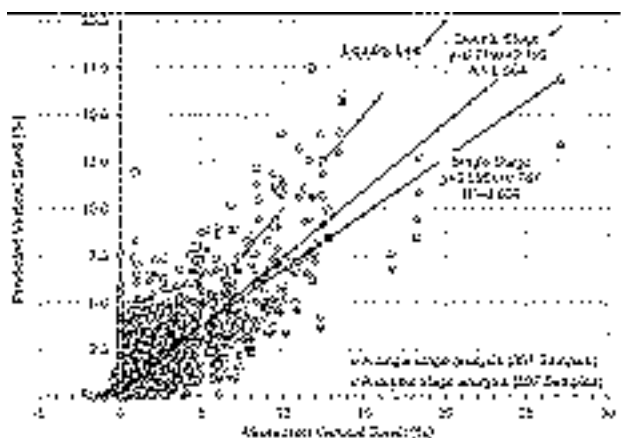

Figure 2 Predicted versus measured vertical swelling of 897 undisturbed samples for the single-stage analysis (i.e., eqns 3 and 4) and the double-stage analysis (i.e., eqns 5 and 6)

The standard error (SE) value associated with the development of this equation is 0.394, and the coefficient of determination ( $R^2$ ) obtained for it is rather low, 0.339. The significance of the 0.394 value for SE is that 68% of total  $P_o$  predictions from eqn (5) are expected to be accurate within a range of  $10^{-0.394}$  (i.e., 0.458) to  $10^{0.394}$  (i.e., 2.182) times the value calculated. Similarly, 95% of these total  $P_o$  predictions are expected to be accurate within 0.210 up to 4.763 times the calculated value. Both these ranges indicate again the existence of an extensive dispersion characteristic in the measurement results, as do the low value values obtained for  $R^2$ . The execution of the second stage is defined by conducting a zero–intercept linear regression on the available vertical swelling test results (i.e., the ASTM 4546 Method B test results) of the remaining 535 undisturbed samples. This leads to the vertical swelling model given by the following equation:

$$Sp = -4.429 \times (P_o/98.07) \times \log(P_p/P_o) \quad (6)$$

This zero–intercept linear regression is shown graphically in Figure 3. This figure indicates that the dispersion of the results is considerable, leading to a low coefficient of determination ( $R^2$ ) of 0.544.

Finally, the prediction of vertical swelling from the combination of eqns (5) and (6) results in a standard error (SE) value of 2.171%, which is higher than that associated with eqns (3) and (4), and a coefficient of determination ( $R^2$ ) value of 0.510, which is lower than that associated

again with eqns (3) and (4). This in itself leads to the conclusion that the application of eqns (3) and (4) for predicting vertical swelling values is preferable.

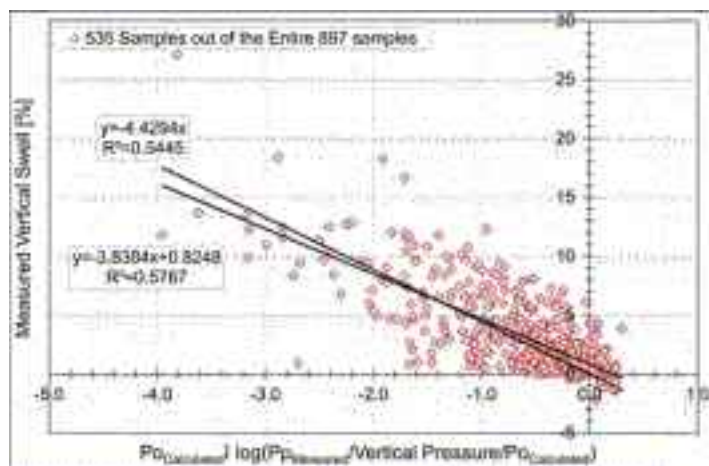

**Figure 3** Measured vertical swelling versus  $Po \times \log(Pp/Po)$  of 535 undisturbed samples, where  $Po$  is the calculated swelling–pressure according to eqn (5) and  $Pp$  is the measured (applied) vertical pressure

Figure 2 also summarizes the overall prediction accuracy of the swelling model given by eqns (5) and (6). The figure indicates that the unconstrained regression line has practically a zero intercept ( $Sp=0.192\%$ ) and a slope value of less than 1 (0.719), thus exhibiting zero bias and, on the average, poor similarity, again, between measured predicted values. These finding are somewhat preferable to those associated with the single stage analysis, although the  $R^2$  value of this analysis (0.604) is higher than that of the double stage analysis (0.564)

Finally, the comparison of the predicted outputs from the three swelling models given is discussed in the following section, which also describes the associated practical conclusions.

#### 4 Comparisons and conclusions

Figure 4 shows a graphical comparison of vertical swelling versus vertical pressure for (swelling models) calculated with the aid of (a) eqns (1) and (2) as derived from 352 undisturbed samples; (b) eqns (3) and (4) as derived from 897 undisturbed samples; and (c) eqns (5) and (6) as derived again from 897 undisturbed samples. The last calculation is done according to the 2–stage procedure; and all three are calculated for a case in which the dry density is equal to  $14.7 \text{ kN/m}^3$  and the ratio of moisture content to plasticity limit equals 0.8.

The figure indicates that the transition from 352 to 897 undisturbed samples does not radically change the pattern of the vertical swelling variation. This indication may suggest that the two basic, predefined equations given in [2] and [3], together with the regression procedure (i.e., the application of the Excel–solver analysis), are appropriate.

In addition, Figure 4 shows that the transition from a single–stage analysis to a double–stage analysis of the same 897 undisturbed samples dramatically changes the pattern of the vertical swelling variation. In particular, it considerably reduces the swelling–pressure values. This change may suggest that the application of a double–stage analysis is questionable.

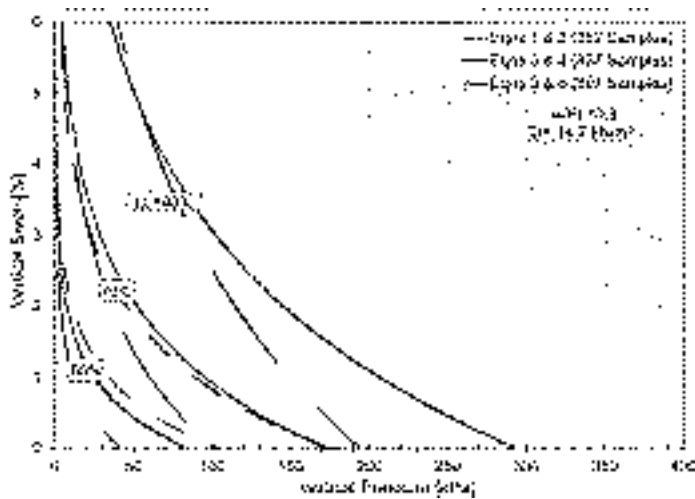

Figure 4 Comparison of vertical swelling versus vertical pressure equations (swelling models) for a dry density of 14.7 kN/m<sup>3</sup> and w/PL=0.8

The summary–statistics of all developments described in the preceding sections is shown in Table 1. To recall, the data in this table are given for the two independent variables, log(LL) and W/PL (i.e., instead of the original LL and w). When the principle of a minimum standard error (SE) is applied to the 897 undisturbed samples, the preferred solution is given by eqns (3) and (4).

Table 1 Summary of the obtained SE, SE/SY, and R<sup>2</sup> values

Section No.	Eqns No.	Number of Samples	Analysis Method	SE %	SE/SY	R <sup>2</sup>
2	1 & 2	352	Excel–Solver	1.45	0.788	0.387
3	3 & 4	897	Excel–Solver	1.95	0.631	0.604
3	5 & 6	897	Double Stage	2.17	0.702	0.510

It is interesting to note that Table 1 indicates that the Excel–Solver solution for the 352 undisturbed samples leads to a lower value of SE than does the Excel–Solver solution for the 897 undisturbed samples although the associated R<sup>2</sup> value decreases. This lower value, however, is not surprising, because the SE/SY value for the 352 undisturbed samples is higher than that for the 897 undisturbed samples. Note: the SY value denotes the standard deviation of measured Sp values. Another conclusion that derives from both Table 1 and Figure 4 is that for the same number of samples, even a small deviation from the minimum SE principle (i.e., 2.17% versus the minimum 1.95%) leads to considerable changes in both vertical swelling and swelling–pressure patterns.

Here, it is interesting to compare the goodness–of–fit statistics of Table 1 with those given in Table 2. This comparison leads to the conclusion that the single–stage analysis and the double–stage analysis (both on 897 samples) can each be categorized as a fair correlation analysis; however, the single–stage analysis is nearer to the good correlation criterion than is the double–stage analysis.

**Table 2** Criterion for correlation as rated by goodness-of-fit statistics (SE/SY and R2) taken from [9]

Criterion for Correlation	Excellent	Good	Fair	Poor	Very Poor
R <sup>2</sup>	≥0.90	0.70–0.89	0.40–0.69	0.20–0.39	≤0.19
SE/SY	≤0.35	0.36–0.55	0.56–0.75	0.76–0.90	≥0.91

Finally, the findings of this paper make it clear that the single-stage operation of the Excel-Solver analysis is preferable to the double-stage operation, consisting as it does of (a) a multiple linear regression analysis for measured swelling–pressure values and (b) a constrained zero–intercept linear regression analysis for measured vertical swelling values (all swelling values except those for zero–value).

## References

- [1] Kassiff, G., Livneh, M., and Wiseman, G., *Pavements on Expansive Clays*, Jerusalem Academic Press, Jerusalem, 1969.
- [2] Komornik, A., and David, D., 'Prediction of Swelling Pressure of Clays,' *Journal of Soil Mechanics and Foundation Division, ASCE*, Vol. 95, No.1, 1969, pp. 209-225.
- [3] Wiseman, G., Komornik, A., and Greenstein, J., 'Experience with Roads and Buildings on Expansive Clays,' *Transportation Research Record No.1023*, 1985, pp. 60-67.
- [4] Wiseman, G., Livneh, M., and Uzan, J., 'Performance of a Full-Depth Asphalt Pavement on Expansive Clay Subgrade,' *Proceedings of the 3rd Conference of the Road Engineering Association of Asia and Australia, Taipei*, 1981, pp. 747-760.
- [5] Livneh, M., and Livneh, A.N., 'The Israeli Guide for Calculating the Surcharge Pressure Required for Pavement Structures Laid on Swelling Clay Soils,' *Proceedings of the Canadian Society of Civil Engineering (CSCE) 4th Transportation Conference (cd Proc.)*, Montreal, 2002.
- [6] Livneh, M., 'Further Developments in the Swelling Model of Expansive Clays under ASTM 4546 and CBR Testing,' *Proceedings of the First International Conference on Geotechnique, Construction Materials and Environment, Mie, Japan*, 2011.
- [7] Livneh, M., 'Recent Developments in the Swelling Model of Expansive Clays for Pavements Upheave Calculations,' forthcoming in the *Journal of Testing and Evaluation, JTEVA (ASTM)*, 2012.
- [8] Najjar, Y.M., Basheer, I.A., Ali, H.A., and McReynolds, R.L., 'Swelling Potential of Kansas Soils, Modeling and Validation Using Artificial Neural Network Reliability Approach,' *Transportation Research Record No. 1736*, 2000, pp. 141-147.
- [9] Dongré, R., Leslie, M., D'Angelo, J., Paugh, C., and Gudimettla, J., 'Field Evaluation of Witczak and Hirsch Models for Predicting Dynamic Modulus of Hot-Mix Asphalt,' *Journal of the Association of Asphalt Paving Technologists*, Vol. 74, 2005, pp.381-442.



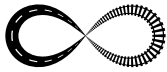

## EXPRESSWAY CONSTRUCTION ON YOUNG KARST IN BRECCIA (VIPAVA VALLEY, SLOVENIA)

**Martin Knez, Tadej Slabe**

*Karst Research Institute, Scientific Research Center of the  
Slovenian Academy of Sciences and Arts, Slovenia*

### Abstract

During precise and longterm monitoring of expressway construction characteristic but for Slovenia relatively rare karst phenomena were discovered in breccia that lie on a sloping foundation of impermeable flysch. We distinguished characteristic types of caves and initial stages in the development of dolines. The largest and most frequent are caves that developed in breccia above the contact with flysch, smaller and most often filled with fine-grained sediment are caves that occur in the middle of breccia, and of special origin are fissure caves across the slopes. Traces of continuous vertical percolation of water are less distinct. Caves also form in the flysch.

The Vipava Valley lies between the high karst plateaus of Trnovski gozd and Mount Nanos to the north and the low plateau of the Classical Karst to the south. Mount Nanos is overthrust on flysch. Below its steep western edge on the sloping flysch, scree material accumulated and consolidated into breccia that developed into a special young karst.

The surface of the slopes was formed by the mass movement and mechanical weathering of rock, which was accompanied on the flysch bedrock by landslides. Water that flowed above the flysch also dissected the slopes. The thickness of the layers of scree material or breccia varies from place to place. More or less vertical fissures developed in the breccia that indicate tensions in the slopes. During expressway construction when the laying out cuts deeply into the slope, the contact between scree material and breccia and the flysch bedrock showed an extremely fragile balance.

*Keywords: karstology, expressway construction, breccia, flysch, Slovenia*

### 1 Introduction

Karstologists have cooperated in planning and studying the construction of Slovene expressways [1, 2, 3, 4, 5, 6, 7, 8, 9, 10, 11, 12, 13, 14, 15, 16, 17, 18, 19, 20, 21, 22]. A large part of the expressway system runs across karst areas. Our mission is to identify and describe the newly discovered natural heritage, and our knowledge, especially about the caves in the karst, is frequently of technical help to road builders.

The Vipava Valley lies between the high karst plateaus of Trnovski gozd and Mount Nanos to the north and the low plateau of the Classical Karst to the south. Mount Nanos is overthrust on flysch. Below its steep western edge on the sloping flysch, scree material accumulated and consolidated into breccia that developed into a special young karst (Fig. 1).

During precise and longterm monitoring of mototrway construction characteristic but for Slovenia relatively rare karst phenomena were discovered in breccia that lie on a sloping foundation of impermeable flysch. We distinguished characteristic types of caves and early stages in the development of dolines.

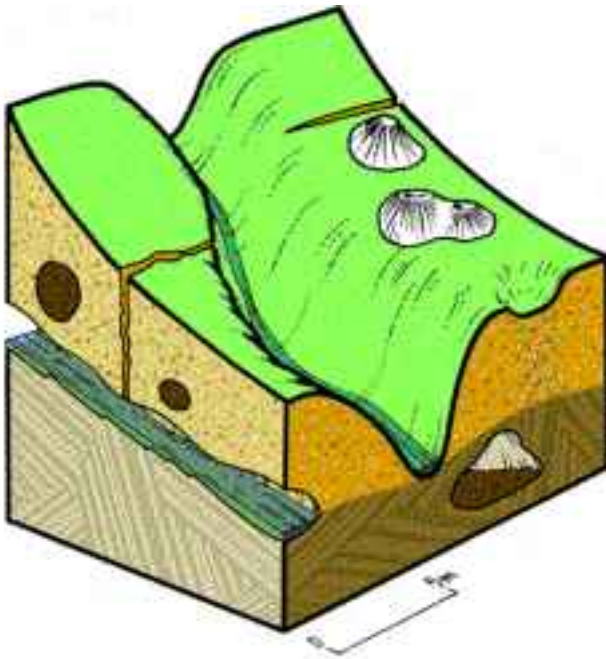

**Figure 1** Karst in breccia and flysch below Mount Nanos in the Vipava Valley: surface karren, with small doline and washed belt of breccia below it and caves in breccia, at the contact and in flysch.

## 2 Site description

The expressway laying out runs across three geomorphologically diverse units along the southwestern slopes of Mount Nanos (Rebrnice and Breg) and the floor of the Vipava Valley. The Breg and Rebrnice slopes are distinct geomorphological units. Mihevc [23] geomorphologically mapped the slopes of Mount Nanos in detail over part of the expressway laying out that runs through the landscape park area. A specific geological thrust structure and specific slope processes and sediments are reflected here in the morphology of the slopes and in botanical anomalies. These features have led to the proclamation of a landscape park covering the southern and western slopes of Mount Nanos.

The surface of the slopes was formed by the mass movement and mechanical weathering of rock, which was accompanied on the flysch bedrock by landslides. Water that flowed above the flysch also dissected the slopes. The thickness of the layers of scree material or breccia varies from place to place. More or less vertical fissures developed in the breccia that indicate tensions in the slopes. During expressway construction when the laying out cuts deeply into the slope, the contact between scree material and breccia and the flysch bedrock showed an extremely fragile balance. After abundant precipitation, numerous smaller streams appeared along the contact between flysch and breccias revealed by the cuts. Many of these streams are exploited for water supply.

Water percolates from the surface in a more or less evenly dispersed fashion through mostly well permeable breccia to the contact with flysch. However, in individual places, traces of continuous percolation of water can be clearly seen in the cross section of breccia and scree material. These are one- to two-meter wide belts of washed scree and breccia, the beginnings of dolines. Above them, small sinkholes formed whose diameters do not exceed three

meters. They are covered with soil. The water from the surface also carries soil containing organic material that further accelerates the dissolving of carbonate rock.

Rainwater has carved rock relief forms on the larger rocks that protrude from the karst surface, the most distinct being flutes and solution pans. Mature flutes take two thousand years to develop [24]. Therefore, the surface of mass movements and landslides on parts of the slopes has not changed significantly for a long time.

### 3 Results

Many characteristic types of caves formed in the breccia that developed on steep and dissected flysch slopes. The largest and most frequent are caves (20) that developed in the breccia above the contact with flysch, while caves (10) that occur in the middle of the breccia are smaller and most often filled with fine-grained sediment. Fissure caves (10) that cross slopes are of special origin. Traces of continuous vertical percolation of water are less distinct. Caves (5) also occur in the flysch.

Remškar [25] collected data on caves in breccia in the Vipava Valley, specifying types of caves and their origins. He divided them into those that developed along fissures, those formed by streams of water, and rock shelters.

#### 3.1 Caves at the contact of breccia and flysch

These are the most frequently discovered caves in this young karst. The diameter of smaller tubes measures only a decimeter while the height of the largest can reach two meters and their width three meters (Fig. 2). The largest parts of the passages are cupola-shaped widenings. These are narrower and higher along fissures. The size and shape of their cross sections varies distinctly from meter to meter along the length of the passage. In places, the shape of the cave reflects the different stages of breccia cementation. The more consolidated the breccia, the smaller the cross sections of passages are in the same conditions. The composition of the rock also dictates the fine dissection of the circumference of the passages. The floors of caves through which water flows are flysch that is only partly covered with pieces of scree material, while the floors of dry caves are covered by scree material and domes of flowstone since breccia tends to disintegrate. There are smaller stalactites on the longer enduring part of the circumference. The thicker layers of flowstone found at various heights in the cave bear witness to times when the caves were filled with fine-grained sediment.



**Figure 2** Cave in breccia at the contact with flysch.



In most cases, individual passages were opened and their connection to a branched network was revealed in only a few places. The largest cave revealed was fifteen meters long. Its central part was a dome-shaped dissected passage. The diameter of the largest dome measured three meters. On the floor, which was largely covered with scree material, a larger stalagmite had formed. We did not observe any traces of water, but a small quantity of water could percolate through the scree material covering the floor of the cave.

Individual caves are filled with fine-grained flysch sediment. Water flowing along the contact carves the flysch bedrock and fills poorly permeable parts of caves. It appears that some of the caves were formed while they were in the process of filling with sediment that is preserved in places and elsewhere was washed away due to the increased conductivity of the caves. Traces of earlier fillings are found in the flowstone crusts preserved at different heights in the cross sections of passages. The lower parts of larger caves are carved deeper into the flysch rock. Often, only smaller continuous streams that have not yet formed distinctive caves are evident in the cross sections of slopes. After abundant precipitation, they flow side by side. This is the consequence of the high porosity of breccia and its contact with flysch. In most cases, the flysch proves to be a poorly permeable rock, especially its upper layer which is weathered and clayey.

The passages of the revealed caves run down the slope. They occurred due to the flowing of water at the contact of breccia and the flysch the breccia covers. The water permeating through the scree material and breccia congregates on the sloping flysch. Conditions for the formation of caves occur along larger continuous streams. Breccia was carried away in a number of places, and smaller valleys formed alongside the streams.

### 3.2 Sediment-filled caves

The diameters of these caves do not exceed one meter, and as a rule they are smaller. The cross sections of the caves are more or less circular or elliptical in shape because they usually formed along the contacts between layers of different types of breccia and along fissures. They are found in all the cross sections of breccias, but primarily in the most consolidated and least porous parts of breccia. As a rule they are filled with brown sediment and soil washed from the surface by water.

The contact between the flysch at the bottom and the breccia above is not flat but distinctly undulating and finely dissected. This is the consequence of the diverse geological structure of flysch, its variously lying layers, and the erosive action of water that has flowed and continues to flow either on the contact with breccia or in smaller valleys on the flysch. Even though there is very porous karst on a slope, less permeable sections, sometimes even flooded zones, form locally and occasionally where caves form in the breccia. Sediments, mainly soil washed from the surface, are deposited in them, and the caves widen along the sediments. In one of the wells used as a foundation for a bridge, water began to appear in the breccia several meters above the contact with flysch.

### 3.3 Fissure caves

Fissure caves form along fissures that developed in breccia. As a rule they cross the slopes. The largest caves, which are several meters or even several dozen meters long, and in places up to one meter wide, are accessible. Most, however, are narrower and do not exceed one decimeter in width. The depth of such caves is conditioned by the thickness of the breccia layers and the characteristics of the fissure. They are shaped by the water percolating in them. Some of these caves are filled with fine-grained sediments and soil where the rock dissolves more rapidly, and the walls of other caves are coated with flowstone. The smallest caves can be completely filled with flowstone.

Caves in flysch

In addition to caves that opened at the contact of breccia and flysch, we also encountered caves that formed in the framework of flysch rock at the contact of marlstone and quartziferous sandstone and of carbonate sandstone and calcarenite.

In some places we observed significant water flow at the contact of carbonate and non-carbonate rock. The contact with non-carbonate rock is not only a water barrier but also an area where water can stagnate and where its level can fluctuate. This causes the washing and carrying away of material, changes in pressure can occur here, and the water can form larger channels. Both limestone and flysch particles are transported along these paths.

In addition, we determined in many places that a small number of underground conducting channels had formed in flysch rock. In places where flysch layers are fractured or folded, water flows along the fissures or spaces between the layers. There is a flow of water along the interbedded contacts due to the almost vertical layers. Water flowing along these contacts carries away flysch material, widens the fissures, and simultaneously periodically or laterally deposits calcium carbonate in different ways. We frequently can observe calcite fillings of fissures that are several centimeters thick. In places the fissures are completely filled, elsewhere up to one centimeter large scalenoedric calcite crystals formed in the fissures, and a number of fissures are covered by a thin (a few millimeters) coat of flowstone. In marlstone with distinctly conchoidal fractures, a number of fissures have been filled with coarse-crystal calcite. It is important to emphasize that the cement is carbonate and that a number of layers can contain much more than 10% of particles of carbonate origin. Therefore both erosion and corrosion occur when water flows through the fissures and along the faults. There is no doubt that karstification takes place to a very small extent.

Heavy weathering of the rock in the interior of the tectonically undeformed block of rock occurs along fissures and faults where the precipitation and surface water flow. Calcium carbonate (flowstone) is deposited at the majority of such contacts.

Caves formed at the contact of marlstone and calcarenite. One of the more characteristic caves of this type, measuring up to five meters in depth and width, opened to the north of the Tabor tunnel at the northwestern part of laying out. Here there are layers of dark grey to black marlstone from a few dozen centimeters to half a meter thick that due to their solidity have a clearly visible conchoidal fracture. The calcarenite is heavily fractured so that numerous calcite veins further increase the content of carbonate. Because the layers have a dip between 70° and 90°, the water passes easily between the layers. Although the calcarenite layers are being intensely dissolved by rainwater, larger cavities or even caves do not form due to the fractured rock.

## 4 Conclusion

The geological, geomorphological, speleological, and hydrological diversity of Slovenia's karst has been demonstrated also by the study of the karstification of breccia that formed beneath the western slopes of Mount Nanos. Water, in most cases percolating diffusely through the permeable surface of scree material or breccia to the more or less impermeable flysch bedrock, creates young karst phenomena.

Rainwater covers large rocks on the karst surface with flutes and solution pans. Fissures crossing the rock in the direction of the slope indicate tensions in the rock mass and its exposure to sliding. Breccia and scree material lie on slanting flysch, and the majority of water flows along the contact causing their instability.

The percolating water collects where the breccia is most consolidated. Earthworks have revealed the early stages in the formation of unique dolines.

Characteristic types of caves developed in the young and very porous breccia, which is consolidated only in places, lying on the more or less slanting flysch, an impermeable bedrock. The true karst caves are small and their development was influenced by the sediment that as a rule fills them. They formed in a locally and periodically flooded zone and they are often

paragenetically enlarged. The largest caves formed above the contact with the impermeable flysch bedrock where the largest streams join. Their shape reflects the varying degrees of consolidation of the breccia. In areas where the breccia is less solid and along fissures, they rise into domes. Along fissures that are the consequence of the sliding of breccia and scree material down the slanting bedrock of frequently saturated flysch, fissure caves formed across the slope; some of them are very long and wide enough in places to make them accessible. As a rule, their walls are covered with flowstone.

To a very small extent, karstification also takes place inside the flysch where the marlstone or sandstone contains at least calcite cement. Karstification at the contacts of marlstone and calcarenite, where caves several meters in size form, is more significant. In places with almost vertical layers, water quickly percolates into the underground, but the heavily fractured layers hinder the formation of larger caves.

Although the described karst is relatively young, discovered in its early development stages, it still reveals all the characteristics of the karstification of breccia in characteristic geological, geomorphological, and hydrological conditions. Good understanding and knowledge of geological and karstological conditions is the base for future planning and interventions in the karst.

## Acknowledgement

The research was included also in UNESCO IGCP project No. 598.

## References

- [1] Kogovšek, J.: Water composition flowing off our roads, *Ujma*, 7, pp. 67-69, 1993.
- [2] Knez, M., Kranjc, A., Otoničar, B., Slabe T. & Svetličič S.: Posledice izlitja nafte pri Kozini, *Ujma*, 9, pp. 74-80, 1994.
- [3] Knez, M. & Šebela, S.: Novo odkriti kraški pojavi na trasi avtomobilske ceste pri Divači, *Naše jame*, 36, pp. 102, 1994.
- [4] Slabe, T.: Karst features in the motorway section between Čebulovica and Dane, *Acta carsologica*, 13, pp. 221-240. 1996.
- [5] Slabe, T.: Karst features discovered during motorway construction in Slovenia, *Environmental Geology*, 32(3), pp. 186-190, 1997.
- [6] Slabe, T.: The caves in the motorway Dane-Fernetiči, *Acta carsologica*, 26(2), pp. 361-372, 1997.
- [7] Slabe, T.: Karst features discovered during motorway construction between Divača and Kozina, *Acta carsologica*, 27(2), pp. 105-113, 1998.
- [8] Mihevc, A. & Župan Hajna, N.: Clastic sediments from dolines and caves found during the construction of the motorway near Divača, on the Classical Karst, *Acta carsologica*, 25, pp. 169-191, 1996.
- [9] Mihevc, A.: The cave and the Karst surface- case study from Kras, Slovenia, *Karst* 99, pp. 141-144, Aix-en- Provence, 1999.
- [10] Kogovšek, J., Slabe, T. & Šebela, S.: Motorways in Karst (Slovenia), *Proceedings & Fieldtrip excursion guide, 48th highway geology symposium, Knoxville*, pp. 49-55, 1997.
- [11] Knez, M., Otoničar, B. & Slabe, T.: Subcutaneous stone forest (Trebnje, Central Slovenia), *Acta carsologica*, 32(1), pp. 29-38, 2003.
- [12] Knez, M. & Slabe, T. & Šebela, S.: Karstification of the aquifer discovered during the construction of the expressway between Klanec and Črni Kal, *Classical Karst, Acta carsologica*, 33(1), pp. 205-217, 2004.
- [13] Knez, M. & Slabe, T.: Jame brez stropa so pomembna oblika na kraškem površju: s krasoslovnega nadzora gradnje avtocest na krasu, 5. slovenski kongres o cestah in prometu, *Portorož*, pp. 29, 2000.

- [14] Knez, M. & Slabe, T.: Karstology and expressway construction, Proceedings of 14th IRF Road World Congress, Paris, CD, 2001.
- [15] Knez, M. & Slabe, T.: Unroofed caves are an important feature of karst surfaces: examples from the classical karst, *z. Geomorphol.*, 46(2), pp. 181-191, 2002.
- [16] Knez, M. & Slabe, T.: Karstology and the opening of caves during motorway construction in the karst region of Slovenia, *Int. J. Speleol.*, 31(1/4), pp. 159-168, 2004.
- [17] Knez, M. & Slabe, T.: Highways on karst (Chapter), *Encyclopedia of caves and karst science*, ed. J. Gunn, Fitzroy Dearborn, New York and London, pp. 419-420, 2004.
- [18] Knez, M. & Slabe, T.: Caves and sinkholes in motorway construction, Slovenia (Chapter), *Sinkholes and Subsidence. Karst and Cavernous Rocks in Engineering and Construction*, eds. T. Waltham, F. Bell, & M. Culshaw, Springer, Praxis, Chichester, pp. 283-288, 2005.
- [19] Knez, M. & Slabe, T.: Dolenjska subsoil stone forests and other karst phenomena discovered during the construction of the Hrastje - Lešnica motorway section (Slovenia), *Acta carsologica*, 35(2), pp. 103-109, 2006.
- [20] Knez, M. & Slabe, T.: Kraški pojavi, razkriti med gradnjo slovenskih avtocest, Založba ZRC, *Carsologica* 7, 2007.
- [21] Knez, M. & Slabe, T., Šebela, S. & Gabrovšek F.: The largest karst caves discovered in a tunnel during motorway construction in Slovenia's Classical Karst (Kras), *Environmental Geology*, 54(4), pp. 711-718, 2008.
- [22] Mihevc A.: Geomorfološko kartiranje ne delo HC Razdrto-Vipava (Rebernice), ki poteka v območju krajinskega parka, IZRK ZRC SAZU, 2001.
- [23] Culver D.C. et al., Karstology and development challenges on karst 2, Construction, tourism, ecology, protection, Založba ZRC, *Carsologica* 14, 2011.
- [24] Gams, I.: Depth of Rillenkarren as a measure of deforestation age, *Studia carsologica*, 2, pp. 29-36, 1990.
- [25] Remškar, B.: Jame v breči na južnem pobočju Trnovskega gozda, *Naše jame*, 46, pp. 4-15, 2006.



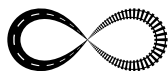

## LARGE EMBANKMENT NEAR SUHAREKË ON THE KOSOVO MOTORWAY

Verica Gjetvaj, Ljerka Bušelić

*Institut IGH, Croatia*

### Abstract

Exploratory works in cuttings of Prizren – Suharekë section (Section 3) of Morinë–Merdare Motorway showed that the properties of material do not fulfill the required criteria without additional treatment, and that deep excavations in such materials will cause slope instabilities. For this reason the adopted vertical route alignment resulted in grade line elevation with the highest embankment height 19 m.

Faced with short construction deadlines a stone material embankment was designed with the intention to complete settling during construction works. A part of the consolidation settlement of the foundation soil was solved by replacement of material, while the consequences of the remaining settlement which will take place over a longer time period, will be treated within the motorway maintenance.

The problem arose when the contractor faced a shortage of stone material during construction and with already completed structures on the subject motorway part.

A solution for the embankment construction had to enable the embankment trunk or embankment body to settle during construction, at the same time keeping the already designed embankment geometry and the slopes resistant to the 100-year floods.

The embankment was designed and constructed with a combination of materials selected from cuts on the route (materials categories B and C) which were placed in layers with load bearing polycarbonate grids placed in between. Finishing parts of every layer on the slope are made of stone material.

*Keywords: motorway, embankment, construction, consolidation, settlement.*

### 1 Introduction

Within the South – East Europe Core Road Network, this Motorway links Kosovo and the South Balkans to the Port of Durres in Albanian, Corridor VIII to the south, and with Niš and further with the Pan European Corridor X in Serbia to the north.

Kosovo represented by the Ministry of Transport and Communications, and supported by the Directorate of Roads, assigned BPI–Consult GmbH (Germany) in June 2004 to provide Consultant and Engineering services for the Morinë – Merdare Motorway Project. As a result BPI prepared a Final Road Design which was completed and submitted in 2005. The planned motorway is 117 km long with two state borderline points, 8 junctions, 105 bridges and 3 tunnels. In April 2010 Bechtel–Enka General Partner signed a contract with the government of Kosovo for the construction of the Morinë–Merdare Motorway, which would be the backbone of the country's national transportation system. Subsequently, Bechtel – Enka GP signed a contract with Institut IGH for preparation of the Preliminary, Detailed and Implementation designs, including geotechnical data for sections 1, 2 and 3, which represent approximately 34.1 km of

motorway connecting the state borderline near Merdare with the town of Suharekë via Prizren. Section 3 from the Prizren Junction to Suharekë Junction is 14.8 km long.

Institut IGH started the analysis and design development for the subject motorway sections on the basis of the Technical Specifications and previously completed Final Road Design by BPI-Consult GmbH (Germany).

The four-lane motorway, from the state borderline with Albania at Morinë to the north of Suharekë, was officially opened on November 2011.

## 2 Why large embankments?

Basic activities, such as surveying, geotechnical investigation works and hydrological analysis were developed parallel to the 'fast tracking design'.

New surveying works were completed and used to prepare the digital terrain model. Surveying reports were submitted and approved by the Client. Geotechnical investigations were developed, as well as laboratory works. Geotechnical reports with designing and construction requirements and definition of slope for the motorway cuts, embankments, stability calculations, settlement, the replacement material, slope protection were prepared and submitted for approval. Hydrological analysis for the external and internal drainage or river diversion was developed in accordance with hydrological data collected for Kosovo. Hydrological reports were submitted for approval.

In the first stage, IGH prepared the Preliminary design on the basis of the adopted motorway corridor, geotechnical investigations and developing surveying data. Optimization of motorway alignment to reduce earthwork quantities and to decrease the length of bridges was the main goals of the design.

Three variants of motorway vertical profiles were analyzed for the developed horizontal alignments of this section. Variants were compared at their critical points like the cut in km 312+800 and embankment in km 313+200. With regard to this large embankment, two variants are significant:

### 2.1 VARIANT XA

This variant was developed in accordance with the original vertical alignment, but on the basis of new surveying data. This was only an initial variant, and not based on the geotechnical or hydrological data.

It is described at the control points as follows:

CUT	km 312+800	max. height is 21.2 m	suitability of material: unknown
EMBANKMENT	km 313+100	max. height is 18.2 m	

With regard to the final hydrological analysis and preliminary geotechnical results, it was concluded that this variant (vertical profile) should be changed.

### 2.2 VARIANT XC

XC variant is described at the control points as follows:

CUT	km 312+800	max. height is 16.9 m	suitability of material: 30%
EMBANKMENT	km 313+100	max. height is 18.8 m	

The variant XC has been developed as the more favorable variant. However, the geotechnical characteristics of the cut material show the possibility of slides.

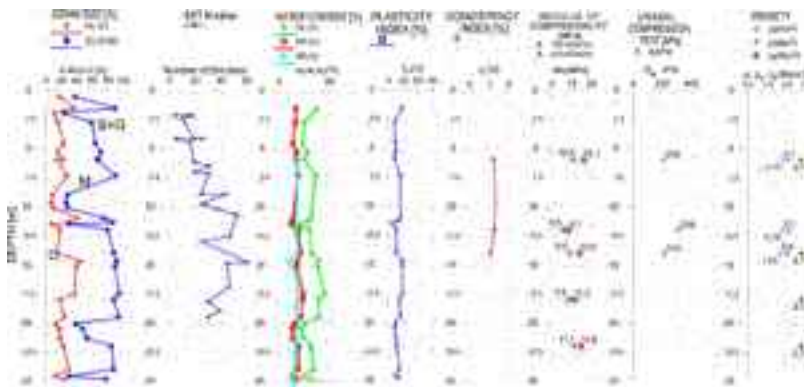

**Figure 1** Layout, km 313 at Section 3 near Suharekë.

'Large' embankment location at km 313+100 crosses the Topluga River at the position where the embankment is not so high allowing the bridge to be shorter. The height of this embankment can not however be reduced because of the high water level, and the overpass clearance which should be approved for the existing road Suharekë–Studenčane.

### 3 Geotechnical properties of the location and the first variant of the embankment structure

The embankment, height >12m, spreads on the route part from km 312+958 to 313+368 (l = 410m). The embankment, height >15m, spreads on the route part from km 313+006 to 313+227 (l = 221m),  $h_{max} = 18.8m$ . Previous investigation works show that large embankments are executed at places where long-term settlements are expected. This is why additional investigations were requested for this part of the route. Borehole S<sub>3</sub>\_BHS\_1320\_1, up to 25 m depth, was performed at the beginning of October 2010. Results of the survey works are presented in Figure 2.



**Figure 2** Graphic presentation of results of performed laboratory and in situ tests



The time schedule of embankment construction of a maximum of 10 months was a limiting factor during analysis and design development. The implemented stability analyses showed that the base has a sufficient bearing capacity. The settling and consolidation analyses showed that the smallest total settling occurs with embankments made of stone material with replacement of foundation soil thickness 2 m. Maximum settling of soil under the 18.8 m high embankment in the central embankment point is 46.7 cm. Out of this total settling height, app. 8 cm, will occur during the construction works, in the first layer of clayey gravel, which spreads up to 4.6 m depth. Another 38.7 cm of settling will take place in the clay and silt layers, and these are the layers where consolidation settling is expected to occur. Summarizing all investigation results the conclusion is that app. 90% of settling will occur in a time period exceeding 100 years. Assuming that the soil parameters used for analysis adequately describe the soil in the area from km 312+900 to km 313+852 and taking into account the analyzed total amount of settling, settling which will take place during construction, the service life of structure, periodic maintenance, time when settling will take place on the subject section, economic and technical feasibility of investment, it was concluded that the subject route section does not require improvement of foundation soil by gravel piles in order to enhance the time period required for settling.

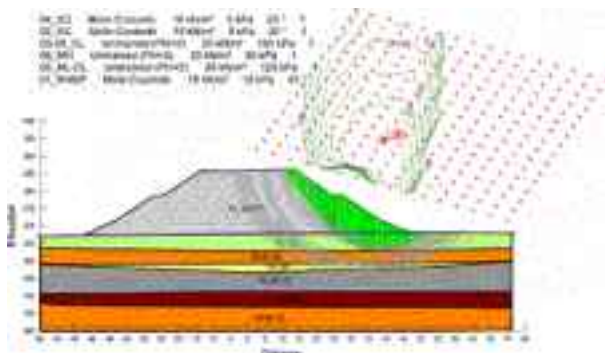

Figure 3 Geotechnical model and results of the calculations of embankment slope stability and the subsoil

#### 4 Change of the embankment structure during construction works

The problem arose when the contractor faced a shortage of stone material during construction with already completed structures on the subject motorway part.

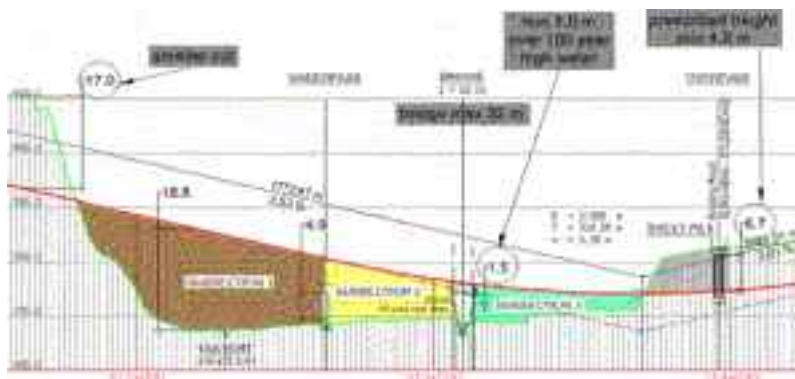
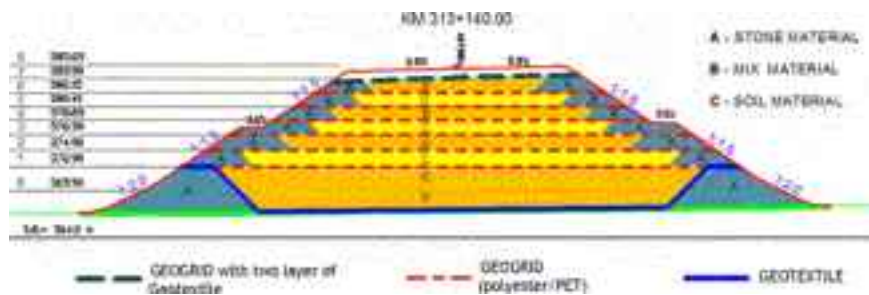

Figure 4 Longitudinal profile of a part of the large embankment.

A solution for the embankment construction had to be such, where the embankment trunk or embankment body will settle during construction (6 months), at the same time keeping the already designed embankment geometry, and where the slopes stay resistant to the 100-year floods. At the same time, the material from excavation had to be used, and the quantity of stone material minimized. Uneven deformation in the cross section had to be stopped as well as uneven settlement along the embankment route. The embankment route includes a bridge, underpass and power cable canal, all of which were in the construction stage. All structures have to function as one unit and settlement in uneven time intervals had to be prevented. The embankment area is divided in three subsections because of different embankment height and arrangement of the material courses according to cross-section height and technology of execution. The solution for the embankment was designed and constructed with a combination of materials selected from cuts on the route (materials categories B and C) which were placed in layers with load bearing polycarbonate grids placed in between. Finishing parts of every layer on the slope are made of stone material.



**Figure 5** Cross-section of large embankment with combination of materials selected from cuts on the route (materials categories B and C).

The figures in continuation present the course of works on the embankment structure, samples of a part of used material, parts of tests for monitoring the properties and forecasting the behavior of material placed in the embankment.



**Figure 6** View of the beginning of embankment construction with material from cutting, which was to be used as material category C, and a view of the test field where it was confirmed that this material is not to be placed in the embankment without improvement.



**Figure 7** Sample of material which was placed as material category B. This sample was tested in three different tests: FR–fragmentability, MDE–degradability and the LA–Los Angeles Value test. It was finally placed in an oedometer where the settling time line was monitored.



**Figure 8** Construction of layers of large embankment covered with geotextile.



**Figure 9** The geogrids were placed over the full embankment width, starting at app. 373 m altitude, which is approx. 0.5 m above the 100–year flood level. A combigrid was installed underneath the road base course over a width of approx 30.9 m. A combigrid was installed transversely to the road axis, with an overlapping of a min 300 mm in both adjacent and longitudinal directions.

Subtype	Subsection 1	Subsection 2	Subsection 3	Total
Designated 0.75Mpa/Cm	11,822	7,800	8,207	28,200
Designated 0.95Mpa/Cm	106,948	17,821	0	124,769
Designated 0.125Mpa/Cm with				
Geogrids	0	0	8,827	8,827
Subtotal	118,770	25,621	17,034	161,425

Material	Subsection 1	Subsection 2	Subsection 3	Total
Gravel Material	99,709	18,209	17,895	135,813
Reinforced Material	18,061	7,382	0	25,443
Geogrid Material	88,219	37,870	18,863	144,952
Total	211,547	63,461	36,758	411,766

Figure 10 Data on the quantities of placed material



Figure 11 Completed motorway on the large embankment part.

## 5 Conclusion

The designed reinforced embankment was completed during September 2011. The information on the quantities of placed material show that the reinforcement of embankment structure brought down the quantity of stone material used to one third. The placed geogrids gave the embankment the required rigidity and brought the differential settling within the tolerated design limits. After the finishing works on the slope improvement have been completed the measuring points were installed in the defined profiles according to the embankment height. The design included monitoring of the displacements. We can only expect that the design assumptions will be confirmed during time on the basis of the measured data and that this will enable a similar form of embankment structure on other locations. The subject embankment is an '1: 1 scale experiment' and as such contributes to the application of reinforcement structures in embankment construction.

## References

- [1] Final and Implementation design of Section 3 Kosovo Motorway Morinë – Merdare, Construction and Geotechnical Design, INSTITUT IGH d.d., Institute for Infrastructure, Zagreb, 2011



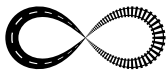

## THE STUPICA TUNNEL – ROCKFALL PROTECTION

Meho Saša Kovačević, Antonia Mirčeta, Lovorka Librić

*University of Zagreb, Faculty of Civil Engineering, Croatia*

### Abstract

The D512 state road is the shortest link between Makarska and Vrgorac. In October 2010, at the site directly before the Stupica ridge, a large rockfall occurred. Under the Stupica location, where the rockfall occurred, there is a very steep slope leading towards the existing arterial road that runs along the coast. In the event of a rockfall and the rolling of large boulders down the slope, there is a high risk of endangerment to the settlement, people's assets existing transmission lines and the arterial roads. This was the largest ever rockfall that had occurred in the Republic of Croatia. The volume of the largest boulders varied from approx. 100 to 250 cubic meters. Following the rockfall, the largest boulders remained lying on the road. A rockfall of this magnitude resulted in large stress changes in the rock mass, thereby threatening the stability of the slope and consequently proving a risk to road safety. Simply removing the fallen boulder pieces and allowing traffic on the road was not possible without undertaking additional measures in securing stability against further rockfalls. In order to eliminate the direct danger to people and property caused by the landslide of rock material, plans were made for constructing a tunnel including additional measures for securing the slope at the tunnel entrance and exit using active and passive rockfall protective measures.

This paper presents the experience gained in geotechnical investigation works, design, construction, supervision, geotechnical measurements and observations during operations. Based on results from completed geological alpine mapping and trajectory simulation of the possible movement of potentially unstable boulders, barriers were designed based on specific numbers, positioning, impact capacity and set heights for protecting against rockfalls.

*Keywords: rockfall, barriers, rockfall protection, tunnel, karst*

### 1 Introduction

The D512 state road is the shortest route between Makarska and Vrgorac, i.e. Ravča (30.6 km). Besides being exceptionally important to local traffic throughout the year and vital for the tourist season during the summer period, it also provides a link to the Ravča A1 motorway node. The road is managed by the Croatian Roads company which is owned by the Republic of Croatia.

On 24 October 2010, on the D512 state road at the section immediately preceding the Stupica ridge, a large landslide occurred, releasing rock masses and subsequently closing the roadway to all vehicles [1]. The landslide happened at a section where a very steep cliff face exists, some 45 – 50 metres above the road, where the rock mass is fragmented into block-like segments with evidence showing discontinuities and fissure systems.

In front of the Stupica location, where the landslide occurred, there is a very steep slope leading towards the main arterial road which runs along the coastline. In the event of a landslide or the rolling of larger blocks down the slope, a great risk is posed to the safety of settlements, people's property, existing transmission lines, as well as the stated main arterial roads.

This is in fact the largest rockfall event that had ever occurred on the Croatian territory. The volume of the largest rockfall boulders ranged from 100 to 250 m<sup>3</sup> in size. Following the rockfall, the boulders remained on the road (Figure 1).



**Figure 1** The rockfall on the D512 state road

The rockfall of this magnitude resulted in large stress changes in the rock mass, threatening the stability of the slope and traffic safety. Simply removing the rockfall boulders and letting traffic pass wasn't an option without the implementation of additional measures for ensuring stability against further rockfalls. Based on a contract signed with Croatian Roads, IGH Corp. drew up the necessary geological and geotechnical exploratory works, the design project, and subsequently the main rockfall repair project.

## 2 The Stupica Tunnel

The main design envisages 'access to threatened' locations using a short tunnel, and carrying out a series of protection works of the most intense rockfall zone. The length of the planned works was approx. 450 m. The total length of Stupica Tunnel is 185 m. The approach cutting slopes directly prior to the tunnel entrance and exit is protected using rockfall protection galleries. The entrance gallery is 30 m long whereas the exit gallery is 15 m. The works for protecting the roadway against rockfall included designing rockfall protection barriers (Figure 2). At its 114<sup>th</sup> session held on 10<sup>th</sup> March 2011, the Croatian Government brought about a formal Decision on the Undertaking Construction in the Event of Direct Danger Posed to the D512 State Road at the Makarska–Vrgorac Section at Stupica. In order to remove direct danger to people and property caused by the rockfall material on the D512 state road at the Makarska–Vrgorac section at Stupica, Croatian Roads were given permission to construct a tunnel and additional associated slope protection at the tunnel entrance and exit.



**Figure 2** The main design – works necessary for rockfall protection

With the aim of accelerating works, particular corrections in the design solution were carried out. Instead of carrying out galleries, the tunnel was extended. This significantly reduced the quantity of works required in constructing the tunnel approach cutting and therefore reduced deadlines. The detailed works project was compiled by the companies IGH, Viadukt Projekt and Viadukt Kontrukcije. The design solution reviews and verifications were carried out by the Faculty of Civil Engineering University of Zagreb. Works were assigned to the company VIADUKT. The Rockfall protection barriers were constructed by OCTOPUS company from Rijeka. Rockfall protection works commenced from the northern side on 15 April 2011. Tunnel excavation works commenced in May 2011. The total tunnel length of 227 m was penetrated on 29 June 2011.

The tunnel penetration was carried out on both sides of the tunnel. Excavation was conducted by blasting and the use of hydraulic impact hammer, and a combination of both. Average daily excavation progress was 3.5 metres per day.

The overburden amounts to 95 m. The area of the excavated perpendicular cross-section is 75.23 – 101.99 m<sup>2</sup>, while the perpendicular cross-section of the clear span is 56.17 m<sup>2</sup>. The width of the traffic lanes is 2 x 3.00 m (Figure 3).



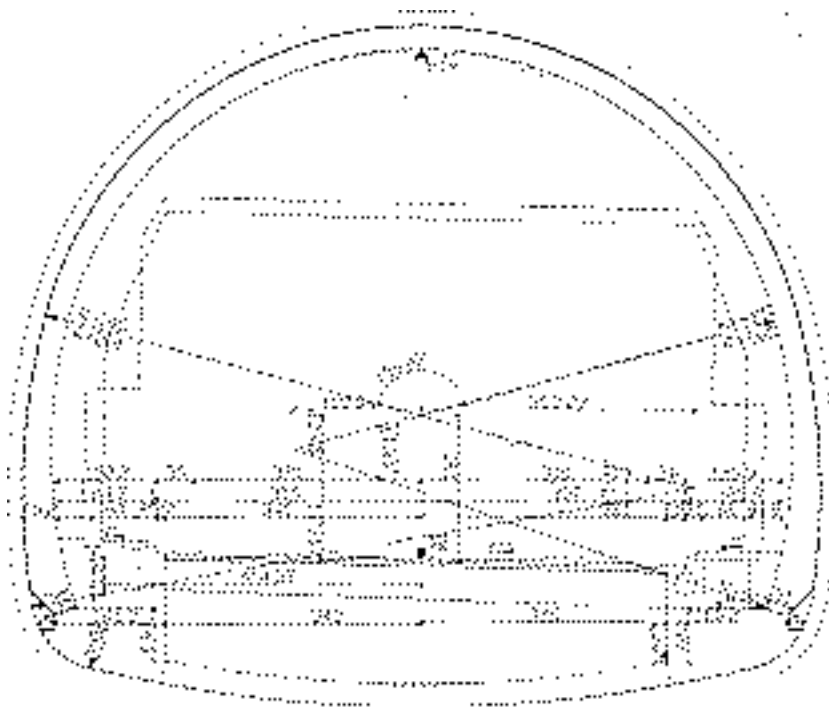

**Figure 3** Perpendicular cross-section of the Stupica Tunnel

Tunnel excavation was carried out as a single geological engineering unit in Upper Jurassic limestones which are a light gray colour, solid, hard, slightly worn out if at all and mainly compacted, partly fragmented by joints which are empty or filled with clay.

Tunnel Construction works covered a total of 158 m of category III. rock mass, 17 m of category IV. and 52 m of category V. rock mass.

There are boulders in the Stupica Tunnel area which due to joint systems have become separated from the main rock, and were found to be unstable. Consequently, prior to commencing tunnel excavation it was necessary to conduct trial blasts for detecting boulder stability. A presumed threshold ground oscillation velocity of 5 mm/s during the blasts in the tunnel would not affect the stability of the mentioned boulders. During the trial blasts, oscillation velocities were measured, including the acceleration and displacements caused by blasting works around the tunnel area. Also, the design involved continually measuring the effects of blasting on the terrain area during works in order to eliminate tunnel excavation works as a cause of instability to particular boulders in the area under observation.

### 3 Geological alpinist mapping of boulders

For the purpose of drawing up the main design for rockfall protection barriers, investigation works were conducted providing a partial insight into the actual state of potentially unstable boulders and zones on the slopes above the future road (tunnel entrance and exit).

According to conclusions in the main geotechnical design for rockfall barrier protection, it was necessary to carry out additional, i.e. complete geological alpine mapping of potentially unstable boulders and rock mass zones.

Based on an existing contract with Viadukt company, the Faculty of Civil Engineering University of Zagreb in cooperation with the Octopus company from Rijeka and Studio di Associato

di Geologia Applicata ed Ambientale from Bogliaco in Italy, carried out geological alpine mapping of unstable boulders and subsequently drew up the respective geological and geo-mechanical report which serves as an appendix to the protection design for the road section affected by the rockfall, i.e. D512 Makarska – Ravča (Stupica section).

Geological alpine mapping recorded 52 unstable boulders (Figure 4). Due to the danger posed by works which could result in the rolling or sliding of some of the boulders situated along the discontinuity surface, it became necessary prior to commencing works to fixate such boulders using a system of anchors, elastic meshes and pre-tensed steel cables in order to protect workers and equipment.



Figure 4 Unstable boulder no 41 located using geological–alpinist mapping

## 4 Rockfall protection

An analysis of the results conducted by geological alpinist mapping, trajectory simulation of the possible movement of potentially unstable boulders and taking into account that due to the essential dynamics in conducting works, instead of entrance and exit galleries, the tunnel was to be constructed longer dimension–wise than anticipated in the main project, and it was therefore necessary to change the number, allocation, energy capacity and height of rockfall protection barriers.

A rockfall simulation at the typically calculated profiles allows for the positioning, defining and dimensioning of rockfall protection barriers which according to their energy capacities, height and inclination can handle the presumed rockfall event. The trajectories of rockfall boulders was analysed using a statistical method in order to predetermine the speed and height of the incoming boulder onto the barrier position [2].

Geotechnical and kinematic analysis was carried out using the software RocFall version 4.054 (Fig. 5) [3]. Designing the rockfall protection system was conducted in accordance with ETAG guidelines [4, 5]. Prior to the undertaking the design procedure, the MEL (Maximum Energy Levels) design approach was utilised.

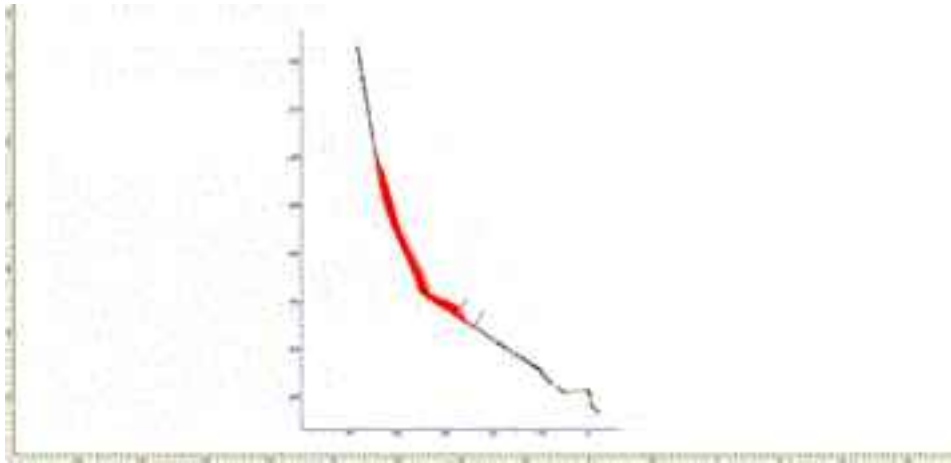

**Figure 5** Calculated inclination profile in km 0+109 with trajectories and positions of calculated and selected barriers BU-3 and BU-4

A solution was chosen in order to achieve satisfactory safety against a rockfall event by using a combination of a systems of so called 'double' barriers possessing an energy capacity of 3000 kJ, at a height of 6 m (Figure 6) and by 'retaining' the larger potentially unstable boulders (which cannot be halted using the barriers) using a system of anchors, elastic meshes and pre-tensioned steel cables (Figure 7). The total length of the barrier is 320 m, four barriers totalling a length of 210 m were placed along the northern approach cutting, and three barriers 110m in length were set up along the southern approach cutting.



**Figure 6** Constructed barriers Retaining unstable boulders



**Figure 7** Retaining unstable boulders

## Conclusion

Rockfall at location Stupica on roadway D512 was the largest ever rockfall event in the Republic of Croatia. The volume of the largest fallen boulders varied from approx. 100 to 250 cubic meters. A rockfall of this magnitude resulted in large stress changes in the rock mass, thereby endangering the stability of the slope and consequently road safety. Geotechnical kinematic simulation and analysis of rockfall caused by detected dangerous boulders at the calculated typical profiles was carried out on the basis of the conducted investigation works, geological alpinist mapping of potentially unstable boulders, boulder mass determination, assessment of critical trajectories for falling boulders and location prospection. As a result of analysis of the rockfall protection system, a solution was selected to meet the safety requirements for rockfalls by using a combination of a system of so called 'double' barriers possessing an energy capacity of 3000 kJ, at a height of 6 m and by 'retaining' the larger potentially unstable boulders which cannot be halted using the barriers.

## References

- [1] Kovačević, M.S.: Sanacija odrona na državnoj cesti D-512, dionica Makarska – Vrgorac, Tunel Stupica, Dani podzemne gradnje 2011, Hrvatska dostignuća u podzemnoj gradnji - sažeci radova, Zagreb, pp. 7-9, 2011.
- [2] Mirčeta, A.: Klasifikacija stijenskih odrona, Dani podzemne gradnje 2011, Hrvatska dostignuća u podzemnoj gradnji - sažeci radova, Zagreb, pp. 73-79, 2011.
- [3] Stevens, Warren D.: RocFall: A Tool for Probabilistic Analysis, Design of Remedial Measures and Prediction of Rockfalls, PhD Thesis, Department of Civil Engineering, University of Toronto, Toronto, 1998.
- [4] ETAG 27, Guideline for European technical approval of falling rock protection kits, European Organisation for Technical Approvals, 2008.
- [5] Peila, D.; Ronco, C.: Technical Note: Design of rockfall net fences and the new ETAG 027 European guideline, Natural Hazards and Earth System Sciences, 9, pp. 1291-1298, 2009.





## A COMPARISON OF 2D AND 3D NUMERICAL SIMULATION FOR TUNNEL EXCAVATION ACCOMPANIED BY MEASUREMENT RESULTS

Mario Bačić, Danijela Marčić, Meho Saša Kovačević  
*Faculty of Civil Engineering, University of Zagreb, Croatia*

### Abstract

Tunnel excavation leads to the redistribution of stress in rock mass. The primary support is not the structure that is to assume the load of the rock mass, but instead in interaction with the rock mass it represents part of the structural system. Deformation of the mass, caused by the progress of excavation, alters its primary stress state causing stress in the primary support. This compression, amongst other factors, depends on the stiffness of the mass and support work, including the shape and size of the tunnel cross-section. The available computer methods in geotechnics, linear and non-linear constitutive equations, as well as 2D and 3D models accompanied by the use of developed computer programs, are considerably more developed and sophisticated than what is posed by utilising a familiarity and description of geotechnical properties of materials that enter such a model. The calculation results are exceptionally dependent on the chosen model and the values of chosen geotechnical parameters. Intensive measuring during tunnel works in carbonate rock mass of a Croatian karst type have shown that the measured deformations are significantly greater than that obtained in calculations which utilise stiffness parameters gained from existing relationships with rock mass classifications and that the measured forms of deformation along the depth are significantly different than those calculated or anticipated in the design. Such measurements have allowed for the development of a new approach to determining the carbonate mass deformation modulus in Croatian karst.

The paper presents a 2D and 3D numerical simulation for the Bobova Tunnel excavation on the D404 national roadway and their comparison with measurement results. In both simulations, a new approach is used to determine carbonate mass stiffness in Croatian karst which provides more reliable deformation forecasting of geotechnical structures.

*Keywords: tunnel construction, numerical modelling, karst, rock mass stiffness, monitoring*

### 1 Introduction

The design engineer of a tunnel, a typical structure in the domain of underground construction, has no choice when it comes to construction materials considering that the fundamental structural material is soil or rock in which the tunnel is constructed. Furthermore, when designing tunnel structures, loads are not important but the forces that occur due to the redistribution of the primary state of stress during excavation. The main tunnel characteristic is that it's a linear structure and, for the purpose of designing, in most cases it is irrational or mostly impossible to implement such a scope of investigation works in order to obtain reliable parameters for design purposes. This reason lies in the fact that the physical-mechanical characteristics of soil and rock may significantly vary along the tunnel route. The largest number of road tunnels in Croatia has been constructed in accordance to the recommendations

of the New Austrian Tunnel Methods (NATM) according to which the procedure for constructing a tunnel is continually adapted to the advancement of combining calculation methods, empirical manner of designing and direct interpretation of geotechnical measurements and observations. NATM, which represents a unique philosophy in tunnel construction, is based on scientifically validated and in practice verified ideas and principles, by mobilising rock mass capacities to achieve optimal safety and cost-effectiveness. It's due to the idea of mobilising the rock mass during tunnel excavation, that the primary support of the tunnel does not need to assume the rock mass load, but in interaction with it forms part of the structural system. One of the four fundamental principles of NATM is lies in in-situ measurements during works, thereby checking deformations and the process of stress redistribution, all for the purpose of fulfilling sought safety levels. Such measurements combined with numerical back-analysis contribute to the development of knowledge gained in rock mass behaviour and determination of its physical-mechanical parameters and linking them to the results of rock mass classification.

## **2 Numerical methods in underground construction**

### **2.1 Numerical back-analysis**

Numerical analysis, whereby material parameters change in accordance to the geotechnical measurement results, is called in professional jargon numerical back-analysis. The principle of back-analysis is that for presumed material characteristics, the stress-strain state is calculated and subsequently the state is compared to measured field results. Since in the majority of cases for presumed parameters the calculated results do not conform to measurements, it becomes necessary to alter the material characteristics until the calculated and measured values coincide with engineering precision [1]. In comparison to investigation works, numerical methods in tunnel construction are very developed and sophisticated, representing a reliable tool for determining stress-strain states which the tunnel will experience during and after its construction. However, a familiar saying is numerical modelling is 'garbage in-garbage out', thereby suggesting the fact that the utilisation of unreliable soil or rock parameters in numerical modelling results in unreliable analysis results.

### **2.2 The finite elements method**

Considering that the problems modelled in the domain of underground construction (and in other engineering sciences) are too demanding to acquire an analytical solution, it becomes necessary to use numerical methods. Computer programs for numerical modelling of underground construction are most often based on the finite elements method or the finite differences method. According to the finite elements method, the continuum that possesses an infinite level of freedom is discretised into a particular number of mutually related (volume) elements. Each element contains a specific number of nodes, where each node has a particular, final number of levels of freedom. Such discretisation provides a particular solution for each element. Therefore, instead of solving problems for a whole volume in a single operation, we formulate a series of equations for each finite element, and mutually combine them with the aim of obtaining a solution for the whole volume. In brief, the solution for structural problems most often relates to seeking a displacement in each node and stress within each element by modelling particular geometry with set material parameters and loads [2]. A computer program, based on the finite elements model and widely used in design practice for underground engineering, is the computer package PLAXIS, with its PLAXIS 2D and PLAXIS 3D modules used in this paper in order to present complex stress-strain relations in rock mass during underground construction works.

### 3 Croatian karst rock stiffness model

Using continual and intensive measurements during numerous geotechnical operations in Croatian carbonate rock karst has shown that the measured deformations are significantly greater than deformations obtained using numerical calculations in which used stiffness parameters are obtained from existing relations with rock mass classifications. Furthermore, the measured deformation forms along the depth are significantly different from those calculated. Therefore, a new approach has been developed in determining the stiffness of carbonate rock in Croatian karst [3,4] which has shown that the parameters affecting stiffness is the geological strength index (GSI), the dispersion velocity of longitudinal waves ( $V_p$ ) and the rock mass deformation index ( $ID_m$ ), where the stiffness is equal to the multiple of the rock mass deformation index, the square of the geological strength index and the square of the dispersion velocity of longitudinal waves. The stated manner of determining stiffness is given using the eqn (1).

$$E_m = ID_m \cdot GSI^2 \cdot V_p^2 \quad (1)$$

where  $E_m$  is in (GPa), GSI in (%) and  $V_p$  in (km/s).

The rock mass deformation index ( $ID_m$ ) for carbonate rocks in Croatian karst is equal to the rock mass quality index (IQs) determined by allocating rock mass into one of the proposed models and weathering zones, whereas the geological strength index (GSI), in completed adapted to the geological engineering properties of Croatian karst [5]. The dispersion velocity of longitudinal waves along the depth, can be successfully gained using seismic geophysical methods for seismic refraction, seismic reflection and hybrid seismic method as a combination of refraction and reflection.

## 4 2D and 3D numerical simulations with measurement results using the Bobova Tunnel example

### 4.1 Description of the Bobova Tunnel

Bobova Tunnel is located on the D404 national roadway and was penetrated in 2005. It passed under the whole Vežica–Sušak town area in Rijeka. It's 210 m long and is constructed as a three-lane tunnel along its whole length. The maximum height of the overburden above the tunnel pipes is 15 m. For the requirements of tunnel design, geological engineering research and testing was conducted previously, as well as testing samples in a laboratory, where it was shown that the tunnel route area is located mostly in Upper Cretaceous deposits, and around the entrance section in older Upper Cretaceous deposits. These deposits represent rudist limestone whose characteristic process is karstification, and therefore it becomes possible for the purpose of numerical modelling to use an approach for determining deformability modulus as described in chapter 3. When taking into account that the stated model uses longitudinal wave velocity as a parameter to calculate stiffness, figure 1 provides the longitudinal geophysical profile for the Bobova Tunnel with an illustration of the longitudinal wave velocity.

Furthermore, geomechanical classification of rock has determined that tunnel along its route is located in category 3, 4 and 5 rock mass ( $RMR = 19-43$ ), and therefore constructed in two excavation phases in compliance with the guidelines from the 'New Austrian Tunnel Methods'. The selected primary support assembly for the tunnel includes two types of anchors: adhesive rock bolt 25 mm in diameter, 6 m long (besides being in places on tunnel walls where it is then 3 m in length) which is located at intervals of 2 m, and the self-penetrating injection anchor IBO 32, 6 m long at intervals of 2 m. Furthermore, for ensuring the tunnel opening, reinforcing steel



mesh type Q-257 were used, including steel trusses Pantex type 95/20/130 and 130/20/30 at intervals of 1.5 m, and shotcrete with a thickness of 0.15 to 0.25 m [6].

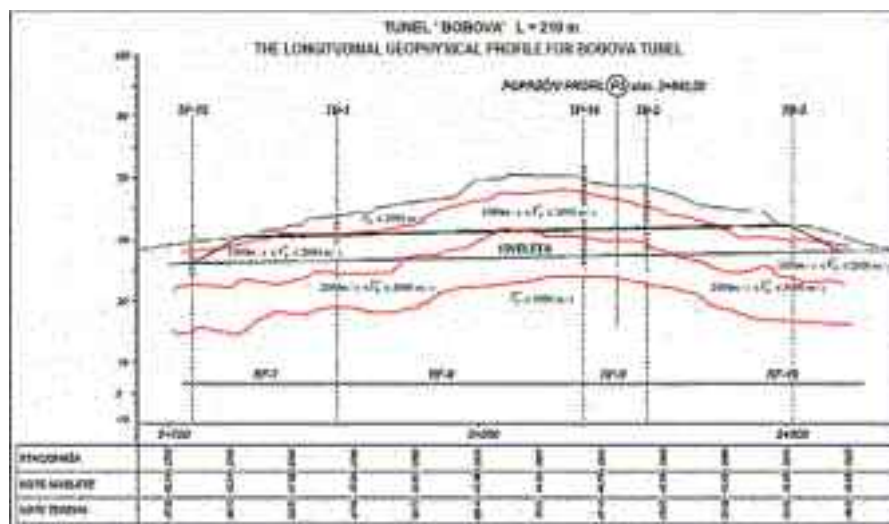

Figure 1 The longitudinal geophysical profile for the Bobova Tunnel

#### 4.2 Two-dimensional numerical model of the Bobova Tunnel

The two-dimensional stress-strain analysis of the Bobova Tunnel was conducted using the PLAXIS 2D computer program. Considering that it is not possible to show tunnel progression using this model, excavation was carried out in two steps. In the first phase, part of the rock was excavated in calottes up to half-way on the tunnel walls, and subsequently the support system elements were assembled. In the next step, the remaining section of the tunnel was excavated, and other elements of the support system assembly were installed. The analysed model with the visible network of finite triangular elements, following the second step, is shown on figure 2. The model comprises of 11 174 elements and 90 149 nodes.

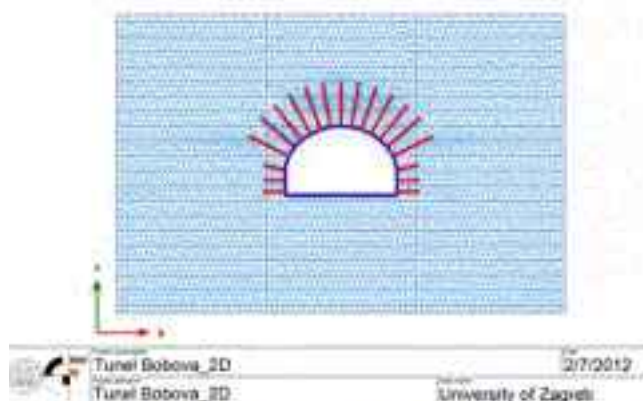

Figure 2 Numerical model of the Bobova Tunnel used in 2D analysis

### 4.3 Three-dimensional numerical model of the Bobova Tunnel

The three-dimensional stress-strain analysis of the Bobova Tunnel was carried out using the PLAXIS 3D computer program. In comparison to the two-dimensional model, the three-dimensional stress-strain analysis can be taken into consideration for incremental excavation progress. Consequently, the number of calculation phases increases, but at the same time the actual state of tunnel construction is simulated, whereby it is then possible to observe displacements in rock mass during tunnel construction. Incremental progress represents the length of tunnel excavation whereby the rock mass remains unsupported. Therefore, following excavation of rock mass in a particular length (length of incremental progress), the support work for the rock mass is carried out, and only then is it possible to continue with the following excavation phase. Incremental progress for Bobova Tunnel three-dimensional model is equal to two metres and conforms to the interval of anchors in the direction of tunnel progression. When taking into consideration what has been said, tunnel excavation was simulated in 38 increments or steps, whereas the model comprised of a total of 140 369 15-node wedge elements, and 202 985 nodes. In Figure 3, the 18<sup>th</sup> step in tunnel excavation is shown with the visible mesh of finite elements. Since the tunnel is axial symmetric, only one-half of the tunnel is modelled.

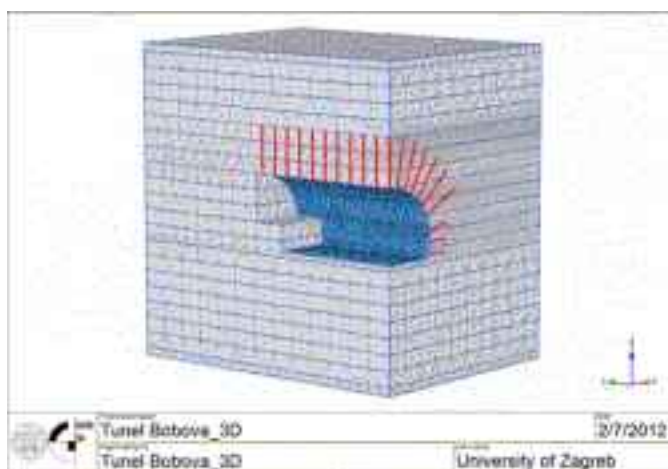
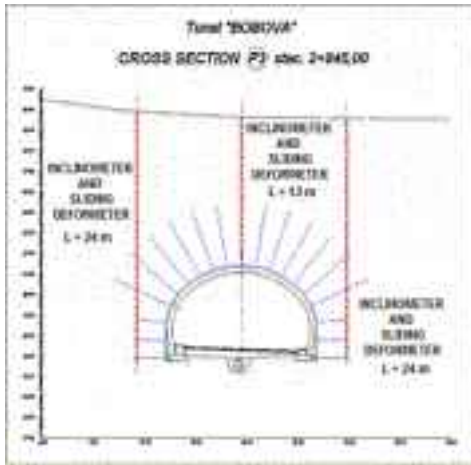

Figure 3 A numerical model of the Bobova Tunnel used in 3D analysis, 18<sup>th</sup> step

### 4.4 A comparison of measured displacements in the Bobova Tunnel accompanied with numerical simulations

During construction of the Bobova Tunnel, continual measurements were taken of the surface terrain using vertical inclinometers with the aim of acquiring horizontal displacements and measurements using sliding deformaters with the aim of acquiring vertical deformations. The measuring profile with positions for the installed inclinometers and deformaters is shown in Figure 4.



**Figure 4** Measuring profile of the Bobova Tunnel with designated positions of the installed inclinometers and deformaters

Figure 5a shows the comparison of horizontal displacements (in millimetres) gained using numerical simulations (two-dimensional and three-dimensional) with inclinometer measurement results, while comparison of the vertical deformations (per mille) acquired using numerical simulations (two-dimensional and three-dimensional) with sliding deformater results is shown in Figure 5b.

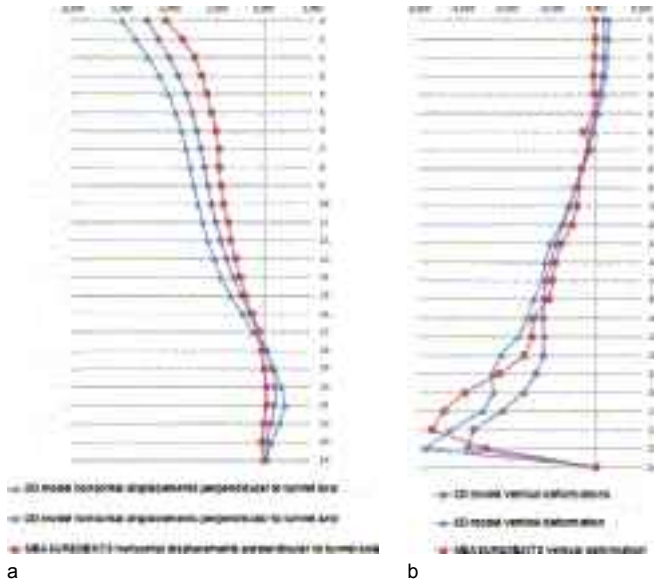

**Figure 5** Comparison of horizontal displacements perpendicular to tunnel axis (a) and vertical deformations (b) using numerical simulations and in-situ measurements

Using non-linear ground stiffness model, described in chapter 2, the numerical stress-strain analysis of the Bobova Tunnel showed that the acquired horizontal and vertical deformations in rock mass, occurring due to excavation, have an approximately identical trend along the depth such as has been obtained from measurement results. In regards to the size of the

deformations themselves, it is evident that the three-dimensional simulations acquire deformations which are closer according to the size of deformations obtained from measurements, than those deformations obtained using two-dimensional analysis. The stated is valid for horizontal and vertical deformations.

## 5 Conclusion

Implementation of numerical back-analysis for tunnel excavation in rock, described in this paper, presents the conclusion that numerical simulations, two-dimensional and three-dimensional, along with the use of the non-linear models for rock stiffness can obtain deformations that based on trends conform to measured deformations. This especially relates to three-dimensional simulations which, besides deformation trends, provide approximate equal values also for the deformation size in comparison to the measured values. The determined differences exist primarily for the reason that numerical simulations take rock mass as the continuum, while in reality it is represented as a discontinuum containing fissure systems that are intersecting. Furthermore, an essential advantage of the three-dimensional model, besides the fact that it provides us with insight into the spatial state of stress, it also provides the ability to analyse deformation in each tunnel construction phase. This analysis allows forecasting rock mass deformation before a particular section has been excavated, and accordingly the necessary measures may be implemented. On the basis of what has been said, the use of three-dimensional numerical simulation is proposed when analysing the state of rock mass deformation during tunnel excavation.

## References

- [1] Kovačević, M.S., Arapov, I., Lušo, P. & Kuželički, R.: Numerical back-analysis for the Pećine tunnel, Proceedings 4. Conference of CGS, Soil and rock improvement, Opatija, pp. 143-152, 2006.
- [2] Logan, D.L.: A First Course in the Finite Element Method, Fourth edition, Nelson Engineering, 2007.
- [3] Kovačević, M.S., Jurić-Kačunić, D. & Simović, R.: Određivanje modula deformacije karbonatnih stijena u hrvatskom kršu, Građevinar, 63 (1), pp. 35-41, 2011.
- [4] Jurić-Kačunić, D., Kovačević, M.S. & Arapov, I.: Novi pristup određivanju krutosti karbonatnih stijena u hrvatskom kršu, Građevinar, 63 (2), pp. 177-185, 2011.
- [5] Pollak, D., Buljan, R. & Podolszki, L.: General engineering geological properties of carbonates in Croatian carst, Proceedings EUROROCK 2009, Rock Engineering in Difficult Ground Conditions, Soft Rock and Karst, Dubrovnik, pp. 143-148, 2009.
- [6] Lušo, P., Kuželički, R. & Galić, I.: Design, supervision and construction of Bobova tunnel, Proceedings 4. Conference of CGS, Soil and rock improvement, Opatija, pp. 163-172, 2006.



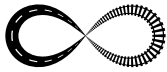

## PROTECTION MEASURES AGAINST DEBRIS FLOWS, USING FLEXIBLE RING NET BARRIERS IN THE TEUFELSKADRICH, GERMANY

Roland Bucher<sup>1</sup>, Corinna Wendeler<sup>2</sup>, Vjekoslav Budimir<sup>3</sup>

<sup>1</sup> GEOBRUGG Australia Pty Ltd, Australia

<sup>2</sup> GEOBRUGG AG, Technical Department

<sup>3</sup> GEOBRUGG AG, Representative Office, Croatia

### Abstract

The steep, shrouded slope along the river Rhine between the German villages of Lorch and Assmannshausen is called the 'Teufelskadrich'. The railway line of the German Federal Railway and the motorway run alongside the river Rhine, between the toe of the slope and the river bench. In July 2008, after heavy rain and thunderstorms, several landslides and small debris flows occurred in the area, which closed the railway line for several days. Twelve flexible ring net barriers were designed, manufactured and installed within two months as part of an emergency procedure. These barriers were tested and developed with 1:1 field tests in a research project in collaboration with the Swiss Federal Institute for Forest Snow and Landscape (WSL). These light weight, ring net barriers are quick to install, and are suitable for slopes with difficult access. They also have the ability to blend in with nature once installed, which was important in the 'Teufelskadrich' area, as the valley is a popular tourist destination. With the new barriers installed on the slope, mobilised material is drained and retained during a landslide or debris flow, by the filtering-effect of the ring net barriers. As an additional measure, some of the deposited debris has been stabilized using a slope stabilisation system, utilising high-tensile chain link mesh and soil nails. Most of the future material is thus already retained in the catchment area, further reducing erosion and limiting mass mobilisation during an event.

*Keywords: landslide, debris flow, flexible ring net barriers, slope stabilisation system, high-tensile chain link mesh*

### 1 The 'Teufelskadrich' locality

Above the Rhine, rise the steep, barren slopes of the Rhenish Massif, an area that experiences rockfall events and isolated landslides (see Fig. 1). From a geological point of view, the locality is situated in the right-bank massif, approximately 10 km west of the village of Rüdeshheim. The mountain range is predominantly composed of very hard quartzites, arranged as slate strata, which in terms of stratigraphy can be assigned to the Lower Devonian. Within the area under investigation, the Rhine flows approximately in a north-south direction at a height of around 80 m above sea level; the top edge of the slope area, which is exposed to the west, is at a height of around 310 m above sea level. Apart from the cliffs, which protrude significantly and in some places can be up to 30 meters in height, the entire slope is covered by a layer of scree several meters thick. With a slope inclination of 30 and, in some places, >35°, this is close to the limit value for equilibrium. Due to the slope's overall morphological situation, with a fold structure that tapers off toward the foot of the slope, the rainfall, which at the top of the slope drains over a relatively large area, is increasingly channelled into isolated

erosion gullies as it flows down the slope. Detailed engineering topographical maps revealed around 3–4 larger main gully structures in the section of the slope under consideration. The concentration of water and debris flow in the natural gullies increases above a certain volume of rainfall, which increases the hazards of debris cover of the existing infrastructure at the toe of the slope.

In the wake of heavy rainfall on 30/07/2008, during which up to 100 mm of rain fell in the vicinity, it was reported that approximately 1,000 m<sup>3</sup> of scree had washed onto the railroad tracks, disrupting rail services, fortunately without causing personal injury (see Fig. 1 on right).

It was important for the German Federal Railway to minimize disruption to their infrastructure, so to prevent further danger to rail traffic (and to road traffic on the federal highway that runs parallel to the railway) attempts had to be made to find an immediate solution to the problem. It was decided the best option was to use ring net barriers, which can be installed quickly and efficiently. In addition, experience had shown that a measure implemented back in 2005 had proven very successful (see Fig. 2 on the left).



**Figure 1** Steep slope with loose material above the river Rhine (left) and material deposited at the railway line after the event in July 2008 (right).

## 2 Ring nets as protection against debris flows

### 2.1 Historical background

Before high-tensile flexible nets were used as protection against debris flows, they were used to contain driftwood as well as snow and rockfall events.

From 2005 to 2008, these nets were tested as debris flow protection in Illgraben, one of the most active debris flow rivers in Switzerland. Utilising 1:1 field tests, their support system was adapted and optimized according to the new requirements. For the first time, specially developed measuring technology was used to measure rope forces in the barriers during a debris flow event, and simultaneously to calculate the density and corresponding pressures exerted by the debris [1]. The field test data and a further 70 complementary laboratory tests were used to derive a load model to dimension these nets. This in turn was implemented into the finite element software FARO [2]. This software will enable engineers in the future to dimension these nets easily and efficiently under practical conditions.

### 2.2 Ring nets as protection against debris flows in the Teufelskadrich

The first three flexible ring net barriers were installed as debris flow barriers in the Teufelskadrich back in 2005. This was done at the same time as the research project began (see Fig. 2). During the event of 2008, these nets succeeded in holding back around 100 m<sup>3</sup> of material. Its projected retention volume had been significantly smaller than the total cubage of the event that occurred.

Geologists and engineers were on site the same day the event occurred, in order to assess the damage to the buried railroad tracks and to begin working out appropriate protective measures. It was clear that the material along the slopes had been deposited by debris flows as they swept downhill. It became clear to all involved that the gullies had to be stabilised to protect the railway tracks and the federal highway. It was also important not to cause major disruption to rail services during the construction phase. The safety of the two transportation routes during the construction phase was paramount throughout this process.



**Figure 2** Installed ring net barrier of 2005 filled after the event in July 2008 (left) and gully after the same event (right).

### 2.3 Statement by the rail operator concerning the planned protective measure

Three debris surges in all had landed on the track of the Wiesbaden–Niederlahnstein rail line between the 71.985 – 72.370 km mark. The mass of debris and mud that had been deposited on and around the track caused the line to be closed in both directions. The necessary measures to protect both transportation routes (railroad and federal highway) against landslides or shallow landslides along this section of the line had to be taken immediately to guard against further dangers.

Due to the severity of the incidents, an external assessor was called in to evaluate the potential risks. The first measure to guard against further dangers and to restore rail services was to clear the line and the safety installations already in place and to repair and restore the damaged safety installations. The following section provides a more detailed explanation of the next steps based on the assessor's evaluation.

## 3 Planning the ring net barriers

### 3.1 Determining the requisite barrier locations

The engineering office tasked with the planning work carried out an extensive on-site inspection to determine the appropriate barrier locations, on the basis of existing gullies and corresponding deposits of loose material. This inspection resulted in 12 ring net barriers to ensure sufficient retention of material as well as several smaller 'debris brakes' to stabilize the gullies and the slope. An additional barrier made from high-tensile steel wire mesh was also used to reinforce excessively steep sections of the slope in the vicinity of the deposited mounds of scree. The next section discusses the dimensioning of the ring net barriers in more detail.



### 3.2 Numerical simulation

The volume of debris displaced was used to make an overall assessment for the event that had occurred. This produced a mobilised volume for the northernmost gully of approximately 500m<sup>3</sup>; the total volume of debris displaced was calculated at around 1,000m<sup>3</sup>. This value was to be guaranteed as a minimum value for the projected retention volume in dimensioning the protective measures to be implemented. The following input variables for dimensioning the ring net barriers were calculated:

- $V_{max} = 500 \text{ m}^3$  per main gully
- Maximum channel slope:  $45^\circ$
- Maximum debris flow density:  $2000 \text{ kg/m}^3$
- Maximum flow  $Q_{max} = 0.135 \cdot V^{0.78} = 17.2 \text{ m/s}$  (calculated empirically [3])

The maximum flow can be used to make an empirical calculation of the maximum flow speed:  $v_{max} = 2.1 \cdot Q^{0.34} \cdot I^{0.2} = 5.5 \text{ m/s}$  [4].

At a maximum gully width of  $b_{max} = 3\text{m}$ , the continuity equation gives a maximum flow height for a wave thrust of  $h_{max} = 1\text{m}$ . Five wave thrusts would thus be required to completely fill a five-meter high system [1].

As an example, the dimensioning of the barriers is shown for debris flow barrier 10. Due to its maximum system height and span width and its location directly within a gully, this fence is one of the determinative systems. The barrier geometry is shown in Fig. 3.

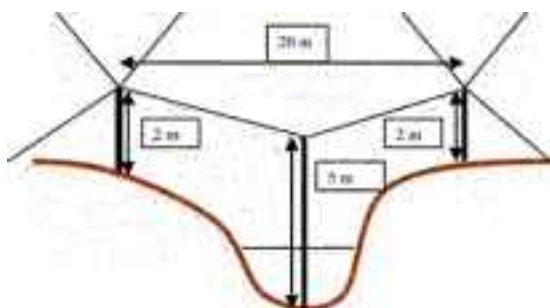

**Figure 3** Decisive geometry for dimensioning of the ring net with middle post height of 5m and the two border posts with 2m height.

The net is dimensioned for the dynamic impact of the first debris wave using the input parameters described above. A dynamic wave impact acts on the lower part of the net with a force along the length of the rope of  $F_{dyn} = \rho \cdot v^2 \cdot h_{max} = 2000 \cdot 5.52 \cdot 1 = 60.5 \text{ kN/m}$  [5].

The corresponding FARO simulation was carried out for this first wave impact (see Fig. 4 on left). For the support system selected, the two lower support ropes had a load factor of just under 60%.

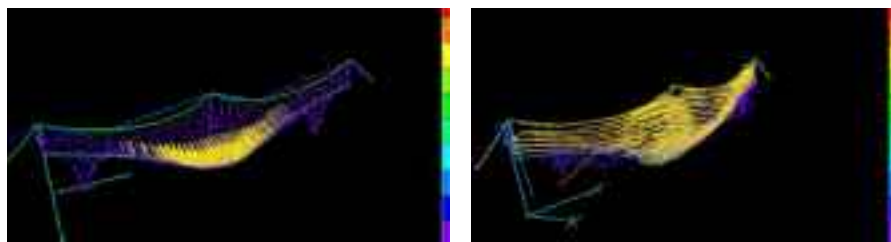

**Figure 4** Results of component utilization with FARO for the first debris flow wave impact on the shown barrier geometry of Fig. 3 (left) and Load case of the full barrier in FARO with the utilisation of the components of 80% (right).

The second determinative load situation involves the barriers being completely full (see Fig. 4 on right). Here, to be on the safe side, the ring net must be capable of bearing the full hydrostatic pressure of the debris given that no more detailed information is available on the drainage behaviour of the debris flow material away from the Teufelskadrich. Thus no statement can be made on how quickly the material drains or how the behaviour of the retained material approximates to the active earth pressure state.

The performed FARO calculations can be used for the planned debris flow barriers system, including the effective anchor forces based on the 1:1 field tests. It was possible to lay out and dimension the other barriers accordingly on the basis of these calculations.

### 3.3 Construction

In consultation with the conservation and the licensing authorities, every aspect of the construction work was supervised by a team of ecological specialists to ensure that the sensitive flora and fauna of the UNESCO World Heritage Site was respected, and to keep disruption to a minimum. These authorities were closely involved in planning and implementing the work. As this project was deemed urgent, it was necessary to ensure during construction work that the barriers were installed as efficiently and quickly as possible, without hindering the passing rail traffic. To protect the rail traffic from rockfall during construction, existing catch fences as well as protective elements used in canal construction, were installed on a provisional basis and rear-anchored. It was thus possible to carry out the protection work while maintaining rail services on both tracks. Due to the steep slopes and the poor accessibility, construction work was often challenging (see Fig. 5).



**Figure 5** Drilling being carried out on ropes (left) and fixing of the ring net after the installation of support ropes (right).

In order to be able to verify the full load-bearing capacity of the projected anchor loads in unconsolidated soil, 10% of the anchors used were checked in stress tests before the ring net barriers were installed. At the same time, the slope stabilisation with the high-tensile mesh and the debris brakes in the flushed-out gullies were completed (see Fig. 6). In order to meet the planned deadlines for completion of the work, close cooperation was required between the contractors, the product manufacturers, the engineers tasked with planning and the principal on-site.

With a three-week planning phase (which also saw construction work begun in parallel,) the entire project was completed successfully in a period of six weeks, with installation work carrying on through adverse weather conditions.



**Figure 6** Slope stabilisation for the loose deposited material (left) and small debris brake at a gully to reduce the flow energy level (right).

## 4 Conclusions

The completion of the twelve ring net barriers for protection against debris flows was the first time such an overall concept had been implemented in Germany. In the Hasliberg region (Bernese Oberland, Switzerland), a similar protection concept had been implemented for the first time since 2005, following floods [5].

The main benefits of these barriers lay not only in the short construction times and the ease of installation in hard-to-reach terrain, but also in the fact that the project had minimized the necessary impact on the protected landscape of the Middle Rhine Valley, a UNESCO World Heritage Site popular with tourists. Even in winter, when most of the vegetation is devoid of leaves, the protective measures can only be spotted with difficulty from the opposite bank of the Rhine (see Fig. 7). The new debris flow nets are marked in red and the old existing rockfall barriers in green in this figure.

Thus this innovative protective measure appears to have benefited both the principal – German Railway AG – which need no longer worry about disruptions caused by debris flows and landslides on this section of line in future, and the natural environment, which has been given adiscreet protection system, that impacts as little as possible on the plant and animal life in the area. The popular tourist region around Assmansshausen is only affected slightly by the new measure and will thus remain a popular tourist destination for the future.



**Figure 7** Installation complete with old rock fall barriers and new installed debris flow barriers. (Source of Fig. 7: Institute of Environmental Planning, Dr. Kübler GmbH).

## References

- [1] Wendeler, C., Debris flow retention in mountain torrents – principles on planning and calculating flexible barriers, doctoral thesis, 2008, Swiss Federal Institute of Technology Zurich, Switzerland.
- [2] Volkwein, A., Numerical simulation of flexible rockfall protection systems, doctoral thesis, 2004, Swiss Federal Institute of Technology Zurich, Switzerland.
- [3] Rickenmann, D., Empirical Relationships for Debris Flows, 1999, *Natural Hazards* 19: pp 47-77.
- [4] Rickenmann, D., An alternative equation for the mean velocity in gravel-bed rivers and mountain torrents, *Proceedings of the 1994 Conference on Hydraulic Engineering*, Buffalo, N.Y., American Society of Civil Engineers, Vol. 1, pp 672-676.
- [5] Wendeler, C., Volkwein, A., Roth, A., Herzog, B., Hählen, N. and Wenger, M.: Hazard prevention using flexible multi-level debris flow barriers, *Proceedings of International Symposium Interpraevent*, Dornbirn, Austria, Vol. 1, pp 547-554.



## 14 INTEGRATED TIMETABLES



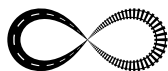

## PERIODIC TIMETABLE CONCEPT FOR THE BOSNIA AND HERZEGOVINA RAILWAY NETWORK

Dženet Ljevo, Andreas Schöbel  
*Vienna University of Technology, Austria*

### Abstract

Periodic timetable presents a timetable by which all network trains are set to travel in regular–periodical intervals. To implement the periodic timetable on the already existing network, the following assumptions must be met. In station areas and in periodic crossroad areas the trains entries and exits must be enabled. The infrastructure on these traffic areas must have the same amount of tracks as there are routes. Also, for an adequate periodic timetable to be established for rail traffic users, there should be a significant speed difference between trains that are of different category. Within the framework of this paper different train routes were simulated for certain parts of the railway network, on which periodic timetables for the B&H railway network were made. Because of the absence in speed difference between different categories of trains, this research showed that for all one rail routes the two hour period is the most convenient one. In the end, a network map shows all of the received results of all the examined segments.

*Keywords: timetable, periodic timetable*

### 1 Bosnia and Herzegovina railway network

The Bosnia and Herzegovina railway network consists of two main routes:

- Paneuropean Corridor Vc: (Luka Ploče) Čapljina–Mostar–Sarajevo–Maglaj–Doboj–Modiča–Šamac → Hrvatska–Mađarska
- Parallel of Corridor X: (Zagreb)–Dobrljin–Novi (Novi Grad)–Prijedor–Banja Luka–Doboj–Lukavac–Bosanka Poljana–Živinice–Zvornik → Srbija

Corridor Vc and the Parallel of Corridor x represent the traffic connections towards Central Europe, Mediterranean Europe, South–eastern Europe as well as towards the neighbouring countries of Croatia, Serbia and Monte Negro. Also, another important route is the so called Unska linija (route Una) from Croatia (Zagreb) across Dobrljin–Bosanski, Novi B&Hać and Račić towards Split (Croatia). Apart from that, the B&H rail network consists of branch lines that connect with the Corridor Vc or the Corridor x. The B&H rail network is 1031 km long, out of which 587km are in Federation of B&H, 417 km in Republic of Serbia and 27 km in Brčko District. Only 87 km of the rail network has a double rail track. All of the electric lines have the same system: AC 25kV, 50 Hz. Because of the partially useless signalization system and the absence of security equipment the maximum speed is limited to 70km/h. Figure 1 shows the present state of B&H rail network.

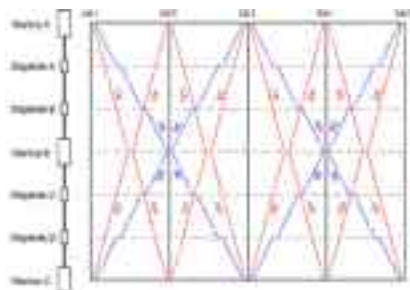



**Figure 1** Bosnia and Herzegovina rail network

## 2 Periodic timetable

Periodic timetable presents a timetable by which all of the networks trains travel in regular periodic intervals. Periodic timetable is, as is the regular timetable, described with a graphical diagram. Period time is usually chosen for 30 min, 1 h, 2 h. Integrated timetable that is in accordance to a period represents a conjunction of different route periodic timetables in a periodic timetables network. Railway network periodic lines are connected with integrated periodic conjunctions (IT-conjunctions). It is characteristic for integrated periodic timetable that the period times can be coordinated in such way that when the trains are stopping the IT conjunctions enable changing between the routes. The next image presents the basic principle of an integrated timetable, for one rail routes, with the absence of the train bypass feature [1], [7]:



**Figure 2** Integrated timetable

The integrated timetable is the consequence of the Swiss railway concept (SBB) of connecting central towns and regions in Switzerland. The regional political project 'Railways 2000' with the motto 'as fast as necessary, and not as fast as possible' is the result of this concept.

## 3 Method

Driving time, for every train, has been calculated with the 'OpenTrack' programme, on which basis the timetables were constructed. The entry parameters for simulation are: infrastructure, transportation vehicles and timetable. Figure 3 presents the 'OpenTrack' simulation timetable that is typical for microscopic simulations of railway traffic.

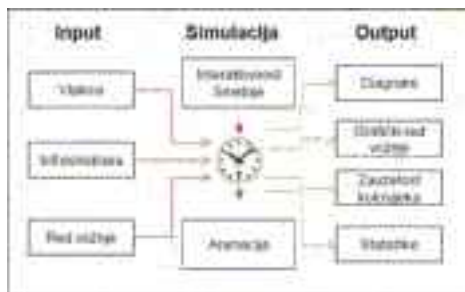

Figure 3 Timeline of the OpenTrack simulation [3]

For the infrastructure depiction in the 'OpenTrack' programme the following data was necessary: the length of the rail track, gradient, maximum route speed, station locations and signal positions. Apart from that, information on train characteristics and the desired departing time were also needed for the simulation. Since the data on accurate positions of signals (inbound and outbound) as well as the distance between signals in the station areas weren't known in detail, this paper approximately assumed the mentioned data. The assumed distances, as well as signal positions, are presented in the Figure 4.

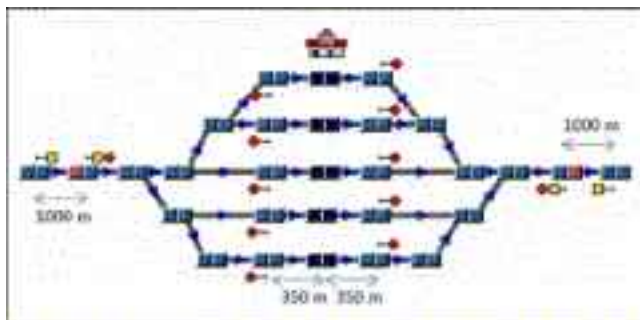

Figure 4 A typical station structure

## 4 Infrastructure segments

On almost all segments of the B&H railroad network, the maximum allowed speed is 70 km/h, and in the station area it is 40 km/h. Fast trains (six coaches) as well as regional trains (three coaches) that are hauled by series 441 locomotives operate on almost every route. On Dobož–Tuzla (heavy traffic) and Bosanski Novi–B&Hać (maximum speed of 50 km/h) route only regional trains operate. Because of the absence in speed difference between fast and regional trains, on most of one rail segments of the railroad network, B&H chose a two hour period. One hour period was successfully applied only on two rail segments and on segments where only regional trains operate.

### 4.1 Sarajevo–Čapljina segment

The 179.3 km long, single track Sarajevo–Čapljina segment presents the southern part of B&H rail network. This segment has 22 stations and 15 stops. In order to establish a periodic timetable, travel duration defined by 'OpenTrack' programme was used for defining the following stations as one hour or two hour conjunctions. One hour conjunctions are stations Sarajevo, Jablanica and Mostar and half an hour conjunctions are Hadžići and Konjic stations. Red li-

nes in the figure 5 represent the fast and the blue lines regional train routes. The train arrival time, technical driving time and stopping time on stations as well as reserve train times are shown in the table 1.

It should be noted, as is visible from the Figure 5, that train bypass of fast trains as well as regional trains occur without notable disruptions. Because the railway crossroads are pre-ordained by infrastructure, further harmonization of timetables reserves is impossible. On parts where the reserved travel time is less than 3% it would be necessary to increase the present speed limit. This can be achieved by maintenance measures and repairs of the track superstructure.

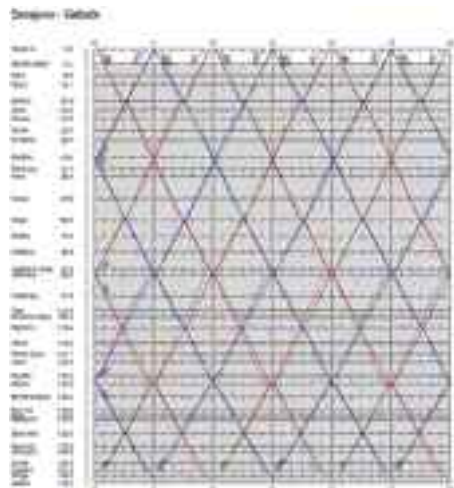

Figure 5 Graphic of the Sarajevo-Čapljina segment timeline

Table 1 Sarajevo-Čapljina segment timeline in tabular form

ICF	Kilometar	Sarajevo - Tuzla					Tuzla - Čapljina				
		ICF	ICF	ICF	ICF	ICF	ICF	ICF	ICF	ICF	
Sarajevo	0	12:00	12:05	12:10	12:15	12:20	12:25	12:30	12:35	12:40	
Novi Travnik	10	12:05	12:10	12:15	12:20	12:25	12:30	12:35	12:40	12:45	
Travnik	20	12:10	12:15	12:20	12:25	12:30	12:35	12:40	12:45	12:50	
Čapljina	80.3	12:45	12:50	12:55	13:00	13:05	13:10	13:15	13:20	13:25	
Tuzla	80.3	12:50	12:55	13:00	13:05	13:10	13:15	13:20	13:25	13:30	
Čapljina	80.3	12:55	13:00	13:05	13:10	13:15	13:20	13:25	13:30	13:35	
Sarajevo	0	13:00	13:05	13:10	13:15	13:20	13:25	13:30	13:35	13:40	
Novi Travnik	10	13:05	13:10	13:15	13:20	13:25	13:30	13:35	13:40	13:45	
Travnik	20	13:10	13:15	13:20	13:25	13:30	13:35	13:40	13:45	13:50	
Čapljina	80.3	13:15	13:20	13:25	13:30	13:35	13:40	13:45	13:50	13:55	
Tuzla	80.3	13:20	13:25	13:30	13:35	13:40	13:45	13:50	13:55	14:00	
Čapljina	80.3	13:25	13:30	13:35	13:40	13:45	13:50	13:55	14:00	14:05	
Sarajevo	0	13:30	13:35	13:40	13:45	13:50	13:55	14:00	14:05	14:10	
Novi Travnik	10	13:35	13:40	13:45	13:50	13:55	14:00	14:05	14:10	14:15	
Travnik	20	13:40	13:45	13:50	13:55	14:00	14:05	14:10	14:15	14:20	
Čapljina	80.3	13:45	13:50	13:55	14:00	14:05	14:10	14:15	14:20	14:25	
Tuzla	80.3	13:50	13:55	14:00	14:05	14:10	14:15	14:20	14:25	14:30	
Čapljina	80.3	13:55	14:00	14:05	14:10	14:15	14:20	14:25	14:30	14:35	
Sarajevo	0	14:00	14:05	14:10	14:15	14:20	14:25	14:30	14:35	14:40	
Novi Travnik	10	14:05	14:10	14:15	14:20	14:25	14:30	14:35	14:40	14:45	
Travnik	20	14:10	14:15	14:20	14:25	14:30	14:35	14:40	14:45	14:50	
Čapljina	80.3	14:15	14:20	14:25	14:30	14:35	14:40	14:45	14:50	14:55	
Tuzla	80.3	14:20	14:25	14:30	14:35	14:40	14:45	14:50	14:55	15:00	
Čapljina	80.3	14:25	14:30	14:35	14:40	14:45	14:50	14:55	15:00	15:05	
Sarajevo	0	14:30	14:35	14:40	14:45	14:50	14:55	15:00	15:05	15:10	
Novi Travnik	10	14:35	14:40	14:45	14:50	14:55	15:00	15:05	15:10	15:15	
Travnik	20	14:40	14:45	14:50	14:55	15:00	15:05	15:10	15:15	15:20	
Čapljina	80.3	14:45	14:50	14:55	15:00	15:05	15:10	15:15	15:20	15:25	
Tuzla	80.3	14:50	14:55	15:00	15:05	15:10	15:15	15:20	15:25	15:30	
Čapljina	80.3	14:55	15:00	15:05	15:10	15:15	15:20	15:25	15:30	15:35	

## 4.2 Sarajevo-Zenica segment

The 80.3 km long, single track Sarajevo-Zenica segment contains 12 stations and 10 stops and is a part of the Paneuropean corridor Vc. In order to set up a periodic timetable, by using the calculated travel time, the following stations were defined as one hour or half an hour conjunctions. One hour conjunctions are stations Sarajevo, Visoko and Zenica and half an

hour conjunctions are Semizovac and Kakanj. On certain parts of this segment time reserves are sometimes more than 25%. The mentioned travel time reserves are necessary so that rail bypass could be carried out on this segment. It should be noted that because of the absence of reserve travel time between stations Rošćevina and Zenica regional trains do not stop. So that stopping of regional trains on every station of this segment could be achieved, the increment of the present speed limit is necessary.

#### **4.3 Zenica–Doboj segment**

The 96.6 km long, double track Zenica–Doboj segment, has 7 stations and 18 stops. In order to set up a periodic timetable, by using the calculated journey time done with 'OpenTrack' programme, stations Zenica, Zavidovići and Doboj were defined as one hour, and stations Nemila, Zavidovići and Ševalije as half an hour conjunctions. One hour period was successfully implemented on this segment of the rail network. The application of one hour period was enabled because of the double track. For this segment we should note that regional trains that travel towards Doboj, because of the single track part of the network between the Jelina and Zenica stations, have a ten minutes train following time. The result is longer stopping time of regional trains in Nemila station. Apart from that, it's been shown that regional trains that travel towards Zenica stop longer in Ševalije station. The cause of these delays in Ševalije station lays in the following times of fast trains that amount to 8 minutes. The mentioned problems could be efficiently optimized through infrastructure improvement measures on which basis a better harmonization (adjustment) of reserve travel time could be achieved.

#### **4.4 Doboj–Tuzla segment**

Not all the relevant data necessary for travel time calculations of the single track Doboj–Tuzla segment is available. The full length of this segment is 87.5 km. The rails gradients that are unknown are in this paper assumed to be 0‰. On the 27.5 km long railway part between Doboj and Jošava, additional stations and stops probably exist that are not known in this paper and because of this they were not taken into account in this simulation. The known part of this segment has 11 stations and 2 stops. Using the calculated travel time (for establishing periodic timetable) stations Doboj, Sočkovac and Tuzla were defined as one hour, and stations Jošava and Lukavac as half an hour conjunctions. On this part of the railway regional trains travel in one hour periods and train crossroads are used as stops as well. It should be noted, for this segment, that regional trains travelling in both directions between Lukavac and Sočkovac stations have low travel time reserves (0.5 %–1.8 %). Stopping time between these stations is about 30 seconds and is already on the lowest level. Travel time reserves can only be increased if some stops are eliminated or if the present speed limit is increased.

#### **4.5 Doboj–Bosanski Šamac segment**

The 60.6 km long, single track Doboj–Bosanski Šamac segment connects the B&H and Republic of Serbia railroad networks. Between stations Doboj and Srpska Kostajnica is a short segment of double railway track. Using the 'OpenTrack' programme simulation, stations Doboj and Modriča were defined as one hour and Bosanski Šamac and Gornja Koprivna as half an hour conjunctions. The simulation showed that fast trains have long travel time reserves that are necessary for periodic timetable travelling. Unlike fast trains, regional trains on some parts of this rail segment have, according to the UIC recommendation, too short time travel reserves. Because of this, trains travelling towards Doboj do not stop between Koprivna Gornja and Srpska Kostajnica.

#### 4.6 Doboј–Banja Luka segment

The 96.5 km long, single track Doboј–Banja Luka segment has 12 railway stations and 14 stops. Using the calculated travel time, railway stations Banja Luka, Pristoje and Doboј are defined as one hour, and railway stations Jašavka and Snjegotina as half an hour conjunctions. Time travel reserves are really short on this segment. Because of the time issue, stopping of regional trains on stations and stops is impossible. Because of the constant follow-up of fast trains, on this part of the railway there cannot be a tact conjunction set up in Pristoje station. Regional trains from Doboј arrive to Banja Luka at 13:11 which is not favourable for establishing a periodic timetable towards Dobrljin. Research showed that establishing a periodic timetable, for this part of the railroad, is really difficult. On one part the problem lies in the speed limit and on the other hand in the absence of crossroad possibilities. For periodic timetable improvements maximum speed increment is necessary. On certain parts infrastructure improvements, meaning construction of a second track on certain parts of the segment, would also be necessary. Speed increment would be necessary at least for the part between Jašavka and Banja Luka, since it would be the basis on which the regional trains would be able to arrive to Banja Luka before the full hour, and because of this the further connection towards Dobrljin would stay undisturbed.

#### 4.7 Banja Luka–Dobrljin segment

The 100.1 km long, single track segment Banja Luka–Dobrljin connects the B&H and Republic of Croatia railway networks. This segment of the railway has 13 stations and 15 stops. For establishing periodic timetable, using the calculated travel time with the 'OpenTrack' programme, stations Banja Luka and Kozarac are defined as a whole hour and stations Potkozarje and Svodna as half an hour conjunctions. On parts where reserve travel times are less than 3% it is necessary to increase the present speed limit. For this segment it should be noted that regional trains travelling in both directions stop on certain parts. This is necessary because the crossing of trains on certain places would be impossible, and the consequence of this would be a disturbance of the whole periodic timetable. It is necessary to increase the present speed limit so that stopping of regional trains on every segment station could be possible. With the maximum speed limit increment a whole hour conjunction on station Bosanski Novi could be established, and this would be of great importance for the rail connection towards Bihać.

#### 4.8 Bosanski Novi–Bihać segment

The 65.9 km long, single track Bosanski Novi – B&Hać segment has 7 stations and 4 stops. On this part of the railway regional trains travel in accordance with one hour period, and train crossroads are used as stops likewise. Using the 'OpenTrack' programme simulation, stations Bosanski Novi, Bosanska Krupa and Bihać are defined as one hour and stations Blatina and Cazin–Srbijani as half an hour conjunctions. Stopping time at stations amounts from 30 to 60 seconds. Short reserve travel time can be increased with the elimination of stops or with the increment in speed.

### 5 Connecting partial results

Figure 6 presents partial results with associated one hour and half an hour conjunctions. The figure represents a scheme of an integrated timetable for the B&H railroad network.

## 6 Overview

This paper tried to establish a periodic timetable concept for the B&H railway network. First, travelling time for fast trains was calculated using several simulations. Assumed travelling time reserves (5–10% of technical drive time) were added to travelling time and after that whole hour and half an hour conjunctions were defined. Then, regional train journeys were simulated and finally periodic timetables were optimised. This research showed that a two hour period is the most suitable for all single track segments of the B&H network. Figure 6 schematically shows all periodic timetables. Also, figure 6 shows how an integrated timetable could look on the present B&H railway network. In the end, it can be said that the periodic timetable implementation, on the present railway network in B&H, is possible. Simulation received travelling time results can be better harmonised through infrastructure improvement measures, on which basis time travelling reserves, where necessary, can be increased. Apart from that, the increment of the present speed limit in certain segments would enable stopping of regional trains on every station and stop. Through the increment of present speed limit, whole hour and half an hour conjunctions could be realised to be accurate in a minute.

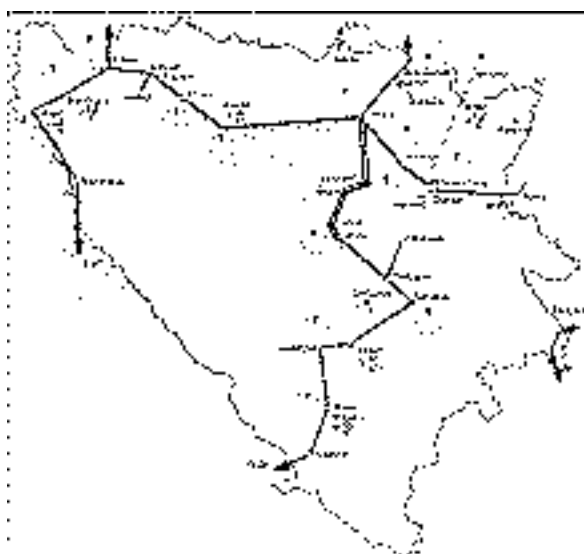
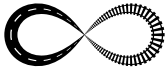

Figure 6 A schematic image of all the results, integrated timetable for the B&H railway network

## References

- [1] Pacht J.: Systemtechnik des Schienenverkehrs- Bahnbetrieb planen, steuern und sichern, 5. Izdanje, Teubner, Stuttgart [u.a], 2008.
- [2] Izjava o mreži, Nr.: 639-XII/2009.
- [3] Simulacija željezničkih mreža, Aplikation OpenTrack, [www.opentrack.ch](http://www.opentrack.ch)
- [4] Studija TER-kompatibilnosti željezničkog Koridora Vc u Bosni i Hercegovini,
- [5] Željeznice Federacije Bosne i Hercegovine, <http://www.zfbh.ba>
- [6] UIC451-1, 'In den Fahrplänen vorzusehende Fahrzeitzuschläge, um die pünktliche Betriebsabwicklung zu gewährleisten-Fahrzeitzuschläge', 4. Izdanje, Dez. 2004
- [7] Bahn 21, VCD e.V 2004





## ON THE DELIVERY ROBUSTNESS OF TRAIN TIMETABLES WITH RESPECT TO PRODUCTION REPLANNING POSSIBILITIES

Sara Gestrelus<sup>1</sup>, Martin Aronsson<sup>1</sup>, Malin Forsgren<sup>1</sup>, Hans Dahlberg<sup>2</sup>

*1 Swedish Institute of Computer Science, Sweden*

*2 Trafikverket, Sweden*

### Abstract

Measuring timetable robustness is a complex task. Previous efforts have mainly been focused on simulation studies or measurements of time supplements. However, these measurements don't capture the production flexibility of a timetable, which is essential for measuring the robustness with regard to the trains' commercial activity commitments, and also for merging the goals of robustness and efficiency. In this article we differentiate between production timetables and delivery timetables. A production timetable contains all stops, meetings and switch crossings, while a delivery timetable only contains stops for commercial activities. If a production timetable is constructed such that it can easily be replanned to cope with delays without breaking any commercial activity commitments it provides delivery robustness without compromising travel efficiency. Changing meeting locations is one of the replanning tools available during operation, and this paper presents a new framework for heuristically optimising a given production timetable with regard to the number of alternative meeting locations. Mixed integer programming is used to find two delivery feasible production solutions, one early and one late. The area between the two solutions represents alternative meeting locations and therefore also the replanning enabled robustness. A case study from Sweden demonstrates how the method can be used to develop better production timetables.

*Keywords: Robustness, replanning, train timetable.*

### 1 Introduction

In Sweden the rail traffic is highly inhomogeneous, and there are inconsistencies between the traffic originally planned for, and the traffic eventually operated. This makes robustness an important issue for the Swedish Transportation Administration. In railway planning, robustness is generally realised by introducing time supplements to absorb delays. As this causes longer travel times and calls for more capacity, various additional recovery strategies have also been explored. In this paper we focus on how the train agent can replan train meetings to minimise the effects of delays, and we present methods for visualising and measuring such replanning robustness.

An important concept in this paper is the difference between production timetables and delivery timetables. Production timetables contain all stops, meetings and switch crossings, while delivery timetables only include stops for commercial activities such as passenger exchanges or associations. We argue that the main goal during planning and operation should be to meet all the commercial activity commitments, and that production timetables should be constructed and later adapted in order to reach this goal. Adaptation is particularly important in Sweden as currently the train diagram which is taken from the yearly train plan will



be for a generic day rather than the actual day of operation. We propose that the production timetables should be optimised for each individual day shortly before operation, and envision the methods presented in this paper to be useful during such an optimisation. Note that the delivery timetable can be constructed from the train plan by extracting the times and locations of all commercial activities.

The paper is outlined as follows: Section 2 presents the state of the art and Section 3 the problem characteristics. Section 4 shortly introduces the modelling tool while Section 5 focuses on the optimisation. We conclude with examples and some final remarks.

## 2 State of the art

There is a consensus in the railway timetabling research field on the characteristics of a robust timetable: A timetable that remains valid despite the small, stochastic disturbances in everyday operations. Likewise, the relationship between time supplements (slack) and robustness as such is undisputed, as well as the implication that constructing timetables involves a trade-off between robustness and short travel times.

What is not agreed upon, is exactly the role of slack sizes in relation to other parameters that affect robustness, and how the slack should be distributed in the timetable to maximise its robustness. Research that explicitly explores how time supplements should be distributed in the timetable to maximise robustness is [1,8,10]. In [12], the generally accepted relationship between homogeneity and robustness in timetables is investigated, and the authors establish a relation between robustness and the time gap (headway) between the arrivals and departures of different trains to and from stations.

The basic approach in [2,7,10,11], although the proposed measures and methods differ, is first finding a good (possibly optimal) timetable with respect to a set of relevant parameters but excluding the robustness aspect, and then in the next step maximising its robustness (according to some definition) while preserving most of the desired characteristics of the nominal timetable. Another recent approach is constructing the timetable while simultaneously evaluating its robustness [8,10].

Entire frameworks like Light Robustness (see e.g. [3]), and Recoverable Robustness [9], have evolved quite recently. [5] empirically compare robustness concepts as well as define their own measure as part of their strategy to get the best trade-off between robustness and other relevant qualities. While different from [5] in many aspects, the measure in [7] is also based on the idea of measuring a distance between a nominal timetable and a proposed (more robust) solution. In [5,7] as well as in the rest of the literature, proposed measures facilitate comparisons of different solutions to the same problem rather than claiming to say something about the robustness of solutions in a broader sense.

## 3 Problem characteristics

During timetable construction, time supplements are added to regulate meetings and to reduce the risk of small disturbances rendering the production timetable infeasible. This means that most trains will have some slack. In a train graph, we define the traversal space as the area between the earliest and latest train paths that fulfil the delivery commitments for a train while ignoring all other trains (see Fig. 1 a). A train thus fulfils its delivery commitments as long as it runs within its traversal space. However, parts of this space will in general not be available due to conflicts with other trains. The time a train can be late (or early) on each link before breaking the schedule, assuming all other trains run as planned, is called link slack.

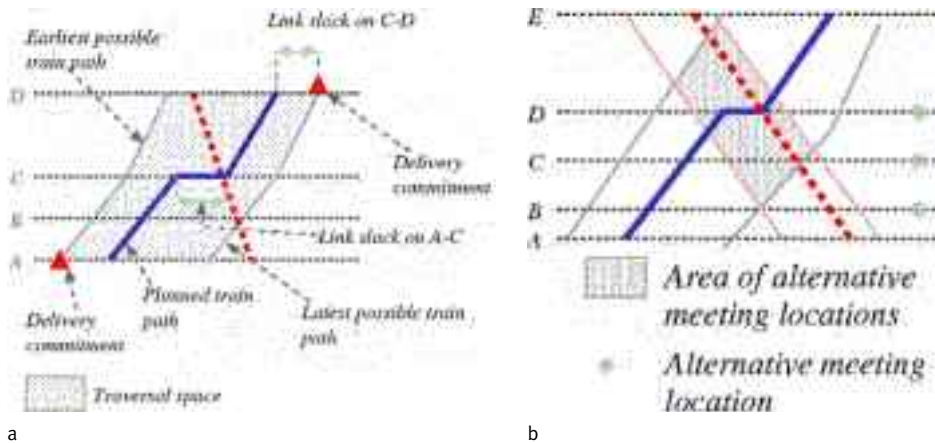

**Figure 1** a) Slack, commitments and traversal space for the solid line train.  
b) Possible meeting locations for a conflict.

When two trains meet, their traversal spaces overlap. If the overlap only contains one meeting location the meeting is critical and can not be moved without breaking delivery commitments. If on the other hand there are multiple meeting locations within the overlap there are alternative meeting locations (see Fig 1 b). However, some or all of these meeting locations may be infeasible due to other scheduled trains.

In this paper we focus on how to optimise replanning robustness between two delivery commitments. That is, the times of the delivery commitments are fixed, and the aim is to find a schedule that is robust with regard to fulfilling the next commitments for the trains given that the earlier ones were met. The propagation of lateness over consecutive delivery commitments is not covered.

### 3.1 Similarities with the CPM/Pert

Our approach for visualizing and measuring replanning robustness bears many similarities to CPM (Critical Path Method) and PERT (Project Evaluation and Review Technique) [6]. In CPM/PERT, project events are represented as nodes in a dependency graph. The edges in the graph are activities, and their weights represent the time it takes for the activities to finish. The graph is used to calculate the earliest and latest possible schedules to determine the time-span, or float, within which each event must take place for the project plan to remain feasible. If all meetings in the train plan are fixed, our situation is analogous to the one above. A meeting is an event, and the delivery commitments are the start and end points. Edges define travel times between meetings. By pushing the meetings as early and late as possible, a float for each link traversal can be obtained. As long as the trains remain within these floats, the delivery commitments can be fulfilled.

If the requirement of fixed train meetings is relaxed, the original weight of an edge in the dependency graph can be changed if one of the edges' meetings has at least one feasible alternative meeting location. This is because the travel time changes if the meeting location is swapped. Changing the edge weight is equivalent to redistributing the slack. This constitutes the core of replanning robustness as it allows for more efficient use of slack. By maximising the number of possible meeting changes, and hence maximising the flexibility of the slack, a more robust timetable can be constructed. An example is shown in Fig. 2.

## 4 Modeling tool

Mixed Integer Programming was used to model and investigate how to adapt the production timetable to obtain replanning robustness. The modelling tool Maraca was used for the optimisation [4]. The general model in [4] was adapted to allow for meeting locations and times to change, while all arrivals and departures specified by the delivery timetable were fixed. In this paper we assume that all timetable locations can cater for all conflict meetings, which may not be true in reality. However, trains are only allowed to stop where they had a planned stop in the original train plan.

## 5 Optimising replanning robustness

Ultimately the goal of replanning robustness is to optimise the useful flexibility of slack. To this aim maximising the number of feasible alternative meeting locations is interesting. Some heuristics are presented below.

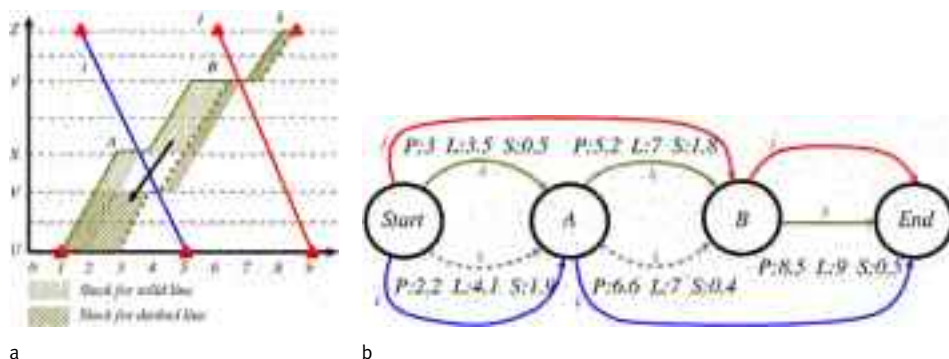

**Figure 2** a) The arrow indicates how changing the meeting location from X (solid line) to V (dashed line) redistributes the link slack.  
 b) The dependency graph for the situation in a). P = planned arrival time to meeting, L = latest possible arrival time, S = slack.

### 5.1 The two-solutions approach

The method used in this paper is based on constructing two feasible solutions (twin solutions), and measure how they differ given some objective function. For example, we can maximise the difference in time between the solutions, or the geographical distance in terms of potential alternative meeting locations.

Variables  $x_{ab}^k$  are introduced for trains a and b on link k.  $x_{ab}^k = 0$  if train a traverses link k before train b, else  $x_{ab}^k = 1$ . Since the method requires two solutions, two sets of trains are used,  $\hat{a} \in E$  and  $\tilde{a} \in L$ . A train  $\hat{a}$  belonging to set E is required to be earlier than its counterpart  $\tilde{a}$  in set L. To this aim we introduce a variable that defines when a train a enters a link k, dak.

Constructing one early and one late solution allows the early solution to be adopted as the production timetable, while the late solution serves as a safety net. Both these solutions are schedules that fulfil all the delivery commitments. The original train paths, which also fulfil the commitments, are found somewhere between the early and late solutions.

There will be a number of alternative meeting locations between the early and late solutions, providing a possibility to redistribute slack (see Fig. 3). Although a single meeting location swap may result in a new feasible timetable, there is no guarantee. Sometimes limited further adaptation may suffice to regain feasibility, but in the worst case the late safety solution may have to be put into operation.

Rather than maximising the number of potential alternative meeting locations, we maximise the number of links that have a start and an endpoint where meeting swaps are possible. In Fig. 3 the links fulfilling this criterion are the ones in the blue area. It is clear that for a link to be in the blue area,

$$x_{ij}^k \neq x_{ij}^k \quad (1) \quad \text{or} \quad x_{ij}^k \neq x_{ij}^k \quad (2)$$

Binary variables  $C_1^k$  and  $C_2^k$  are introduced to signal whenever Eqns. (1) or (2) are true respectively.  $c$  is zero when its condition is false.

In order to only have links that are either completely in the shaded area, or completely outside it, we force all meetings of early and late trains to be on a timetable location. However, time supplements have not been added to regulate these meetings, so they may not be operable in real life. As a consequence, the uppermost and lowest links may not be feasible for meeting swaps. The model used is the following,

$$\begin{aligned} x_{ij}^k + x_{ij}^k - C_1^k &\geq 0 & x_{ij}^k + x_{ij}^k - C_2^k &\geq 0 & x_{ij}^k + x_{ij}^k + C_1^k &\geq 0 \\ x_{ij}^k + x_{ij}^k + C_1^k &\leq 2 & x_{ij}^k + x_{ij}^k + C_2^k &\leq 2 & x_{ij}^k + x_{ij}^k - C_1^k &\leq 0 \\ x_{ij}^k + x_{ij}^k + C_2^k &\geq 0 & d_i^k &\leq d_i^k & & \\ x_{ij}^k + x_{ij}^k - C_2^k &\leq 0 & x_{ij}^k, x_{ij}^k, C_1^k &\text{and } C_2^k &\text{binary} & \end{aligned}$$



Figure 3 The alternative meeting locations are the ones in the shaded area.

## 5.2 Maximising the time difference

To maximise the time difference between the two solutions define  $df_i = d_i^k - d_i^k$ , and use the objective function

$$\max \sum_{ik} df_i^k \quad (3)$$

The model with the objective function defined in Eqn. (3) is called problem A. Although this model allows for different meeting patterns it does not reward it. The objective function results in the safety net being far away in time, but ignores the number of steps between the two solutions (as defined by the possible meeting location swaps for pairs of trains). This will limit the robustness gains.

## 5.3 Maximising the number of alternative meeting locations

Rather than maximising the time difference we may maximise the geographical distance in terms of potential alternative meeting locations between the two solutions. The objective function is,

$$\max \sum_{k \in \text{Links}} C_1^k + C_2^k \quad (4)$$

The model with the objective function defined in Eqn. (4) is called problem B. The objective function maximises the potential alternative meeting locations, but it does not take into account how much slack a potential meeting swap might redistribute. For the slack redistribution to be as efficient as possible this needs to be considered as well.

## 6 Examples

The methods described in Section 5 were tested on a part of the Swedish infrastructure consisting of a single track line with 62 geographic timetable locations. Two days were chosen at random from the 2011 train plan, namely day 98 and 101. The problems included 1488 and 2021 link traversals respectively, which provided for a total of 811 and 1734 potential realisations of meetings if only delivery commitments were considered. The results are presented in Fig. 4 and Table 1. Fig. 4 is the train diagram for day 98 where the twin solutions from problem A are plotted. Table 1 shows the results after optimisation. As expected there is a trade-off between time and potential meeting points.



**Figure 4** Areas between the two solutions for the distance Boden–Vännäs in the 2011 train plan. The early solution is plotted in black and the late in grey, and the area between the two solutions is shaded.

**Table 1** The time difference and number of potential alternative meeting locations for the two objective functions.

Objective function	A		B	
Day	98	101	98	101
Sum of time difference over all geographical locations (seconds)	1142986	1277343	641138	920985
Potential alternative meeting locations	118	224	144	239

## 7 Final remarks and future research

This paper presents the concept and models of replanning robustness. The fundamental idea is that by changing train orders on links during operation, slack can be geographically redistributed to absorb delays where they are occurring. We introduce heuristics for investigating and constructing timetables that allow for such flexible use of slack, and test the methods on a case from Sweden.

The concepts and models presented in this article are still being developed, and this paper should be considered a first step towards a full methodology. We plan to further investigate and experiment with these ideas and models.

## References

- [1] Andersson, E., Petersson, A. & Kaseman, J.T.: Robustness in Swedish Railway Traffic Timetables, RAILROME, 2011.
- [2] Fischetti, M & Monaci, M.: Light Robustness (Chapter), Robust and Online Large-Scale Optimization, Robust and Online Large-Scale Optimization, eds. Ahuja, R., Möhring, R. & Zoroliagis, C., Springer Berlin / Heidelberg, p.p.61-84, 2009.
- [3] Fischetti, M., Salvagnin, D. & Zanette, A.: Fast approaches to improve the robustness of a railway timetable, *Transportation Science* 43(3), p.p. 321-335, 2009.
- [4] Forsgren, M., Aronsson, M., Kreuger, P. & Dahlberg, H.: The Maraca – a tool for minimizing resource conflicts in a non-periodic timetable, RAILROME, 2011.
- [5] Goerigk, M. & Schöbel, A.: An Empirical Analysis of Robustness Concepts for Timetabling, Proceedings of the 10th Workshop on Algorithmic Approaches for Transportation Modeling, Optimization and Systems, 14, pp. 100-113, 2010.
- [6] Hillier, F.S. & Lieberman, G.J.: Project Planning and Control with PERT-CPM (Chapter), Introduction to Operations Research 6th Edition, eds. Munson E.M. & Amerman S., McGraw-Hill, Inc., 1995.
- [7] Khan, M.B. & Zhou, X.: Stochastic Optimization Model and Solution Algorithm for Robust Double-Track Train-Timetabling Problem. *IEEE Transactions on Intelligent Transportation Systems*, 11(1), pp. 81-89, 2010.
- [8] Kroon, L.G., Dekker, R. & Vromas, M.J.C.: Cyclic Railway Timetabling: A Stochastic Optimization Approach, Algorithmic Methods for Railway Optimization, Lecture Notes in Computer Science, eds. Geraets, F., Kroon, L., Schoebel, A., Wagner, D. & Zoroliagis, C., Springer Berlin/Hiedelberg, pp. 41-66, 2007.
- [9] Liebchen, C., Lübbecke, M., Möhring, R.H. & Stiller, S.: Recoverable Robustness. Technical Report ARRIVAL-TR-0066, ARRIVAL Project , 2007.
- [10] Liebchen, C., Schachtebeck, M., Schöbel, A., Stiller, S. & Prigge, A.: Computing delay resistant railway timetables, *Computers & Operations Research*, 37(5), pp. 857-868, 2010.
- [11] Salido, M. A., Barber, F. & Ingotlotti, L.: Robustness in railway transportation scheduling, 7th World Congress on Intelligent Control and Automation, Chongqing, p.p. 2880-2885, 2008.
- [12] Vromans, M.J.C.M., Dekker, R. & Kroon, L.: Reliability and heterogeneity of railway services, *European Journal of Operational Research*, 172(2), pp. 647-665, 2006.



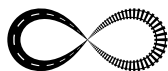

## INTEGRATED PERIODIC TIMETABLE IN HUNGARY – EXPERIENCES, HELP FOR VISION

Viktor Borza<sup>1</sup>, János Földiák<sup>2</sup>

*1 VPE Rail Capacity Allocation Office Ltd., Hungary*

*2 MÁV–START Hungarian Railway Passenger Transport Co.,  
Product Development Department, Hungary*

### Abstract

This paper describes the integrated periodic timetable (ITF – abbreviation from German term *Integrierter Takt Fahrplan*) on Hungarian railway networks within its introduction and future. The project for a new timetable began in 2004 with a pilot project on suburban lines around Budapest. Income increased by approximately 12 percent in the first months, wherefore it was decided for the extension of the system to cover the majority of the railway network. The main step started in 2006, in the eastern part of the country. The backbone of the system is a new InterCity network, with hourly services between all major cities in the eastern and northern part of the country. In the following years the implementation of the system for the entire network has slowed down, but now we have ITF on all important lines of the network. On lines where the ITF was implemented, it has stopped the previous constant 10–12 percent yearly decrease in ridership, moreover on all hourly system ITF lines passenger numbers further increased a few percent.

*Keywords: ITF, Hungary, integrated periodic timetable, results*

## 1 Introduction of ITF in Hungary

### 1.1 Pilot project

In 2004 according to the strategy of the Hungarian State Railways (MÁV Rt.) a project called 'Suburban Railway Development Project' was started. The aim of this project was to determine the passenger demands, provide better services with a basically new timetable structure, new vehicles and infrastructure developments.

As a pilot project, a new ITF system timetable was introduced on two suburban lines carrying heavy commuter traffic. Budapest–Vác–Szob line running along the river Danube is not just a suburban line but an international link to Slovakia, Czech Republic, Poland and Germany as well. It is double track, electrified, equipped with multi-direction automatic block control and the allowed speed is 100–120 kph. Budapest–Veresegyház–Vác line is a secondary line by terms of infrastructure, it is single track, electrified and equipped with centralized traffic control. The allowed speed is about 60 kph.

The structure of the new timetable: Budapest–Vác–Szob line is divided into two zones, the inner circle ranges from Budapest to Vác, and the outer circle from Vác to Szob. The inner circle is served by stopping trains in every 30 minutes. The outer circle has trains in every 60 minutes which skip all stops in the inner circle. For this structure we use the 'zoning system' term, and the trains skipping stops in the inner circle are called 'zoning trains'.



On Budapest–Veresegyház–Vác line, due to the infrastructural conditions (single track), just a simple, symmetric and periodic timetable was introduced with additional fast trains running in the peak hours.

The suburban lines together with the connecting railway lines, the regional buses and the ferry on the Danube construct a complete transport system based on intermodal relations. The application of the zoning system resulted in a significant journey time decrease for about 30 percent of the passengers. The new system did not cause unfavourable changes in service frequency or journey time for any of the passengers. Despite the fact that there is a new highway between Budapest and Vác, the 25 minutes journey time of the zoning trains running at 120 kph is absolutely competitive. Travelling by train from the suburbs directly into the city centre became by far the fastest way.

In the new timetable there are 43 percent more trains, but the total costs increased only very slightly by about 0.4 percent, mainly caused by the higher traction energy consumption. This is due to the fact that the percentage of variable costs in the cost structure of the suburban railway traffic is quite low. [1]

## 1.2 ITF–East

As a result of the success of the pilot project in the Budapest area, a further extension of the ITF principle was decided in 2005. Due to the size of the project and considering the available resources, the timetable reform was planned to take place in two steps. In the first step the ITF system was planned for the eastern part of the country and the Budapest–Vienna line. The significant structural change of the 'ITF–lines' required to modify the timetable of the connecting branch lines and bus routes as well, so the periodic timetable simply spread through the eastern part of the country.

The backbone of the timetable is the new InterCity network, which connects all major cities of Eastern Hungary. InterCity trains are the flagships, they stand for higher comfort and less stops, shorter journey times. The new system is based on two core–routes:

- The two hourly circle InterCity trains from Budapest, via Miskolc, Nyíregyháza, Debrecen and Cegléd, back to Budapest, with hourly frequency between Budapest and Miskolc as well as between Nyíregyháza and Budapest.
- The hourly InterCity trains from Budapest to Szeged.

The two routes are connected at Cegléd, which became the most important network hub (node used as the connection points of the integrated periodic timetable) in the system. This way the cities of the Hungarian Great Plain have periodic connections hourly.

On the ITF lines, the overall increase of train–km output was 22 percent, mainly caused by the new commuter services and long–distance trains. The new timetable was heavily based on better utilisation of the existing resources, especially the rolling stock. This was achieved with optimised (and sometimes shorter) turn rounds and reorganization of maintenance works.

Similarly to the successful periodic timetable pilot project, the extension of the ITF system to the eastern part of country also proved to be successful. Although the start–up was not free of problems, the railway staff and the passengers quickly got used to the new system. [2]

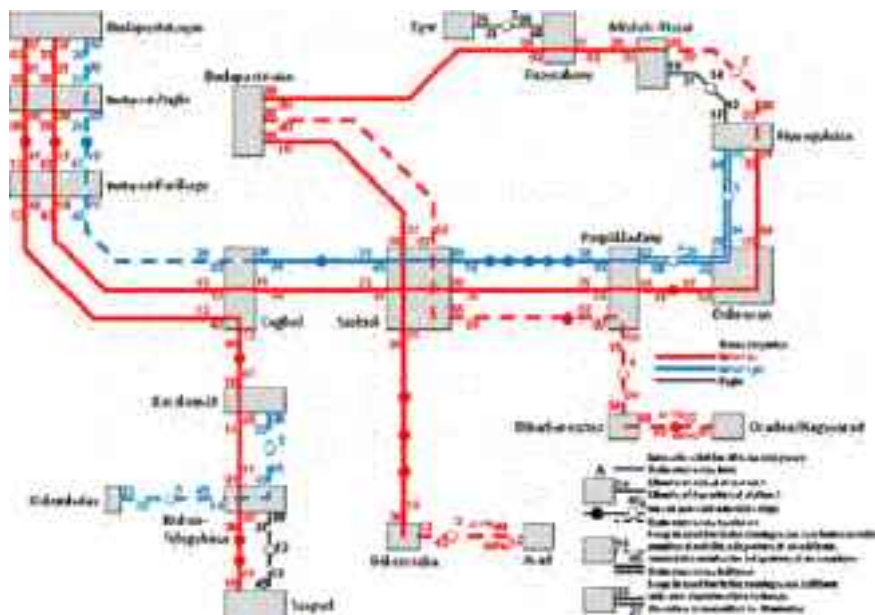

Figure 1 Timetable-map of the current interregional ITF system of Eastern Hungary

### 1.3 ITF-West

The development of ITF was much slower on the rest of the lines, but now we have ITF system timetable on all the main lines, only a few regional and interregional lines in Transdanubia are still missing. The ITF-West was introduced step by step, first on the suburb lines, then on the Budapest-Pécs line and at the south shore of the Lake Balaton, and finally on a few interregional lines like Sárbogárd-Szekszárd. The development was slow, because the railways lost its competitiveness already in the 80's, the major cities were served mainly by buses, and the state didn't want to have a new competitor of the as well state financed bus companies. But since the ITF started to work in Transdanubia too, in every year there are more and more lines, where the trains take more passengers and the buses loose. In 2012, there is two hourly frequency ITF on all the main lines and on most of the interregional lines, and there are plans to develop hourly service on all the main lines.

## 2 Results of Hungarian ITF adaptation

The pilot project was the most successful timetable development in Hungary; it has increased the passenger numbers about 40 percent since its introduction. This massive success was also because of the zoning system, and the much shorter journey times. There were no vehicle or infrastructure developments, the lines are still working under the same conditions, as it was before the introduction of ITF.

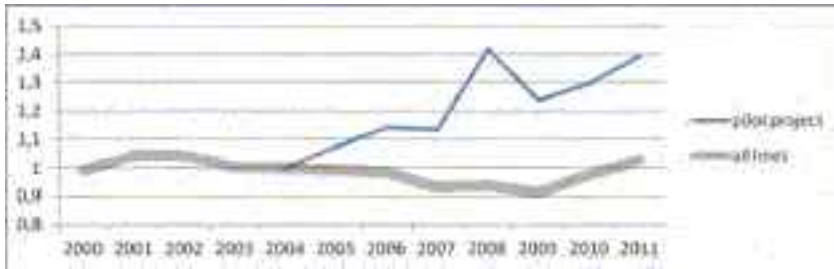

**Figure 2** Changes in number of passengers on the lines of the pilot project compared to the same index on the network. 1 (100 percent) means the number of passengers in 2000 [3]

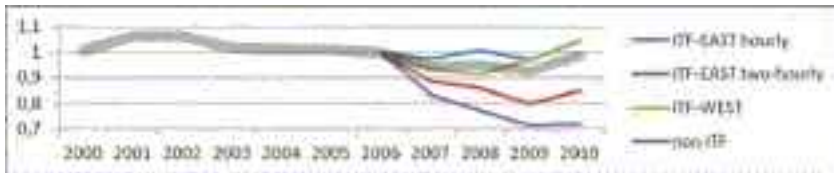

**Figure 3** Changes in number of passengers on the lines of ITF-East project compared to the same index on the network. 1 (100 percent) means the number of passengers in 2000 [3]

During the first two years following the introduction of ITF-East the railway ticket prices have been raised by altogether more than 30 percent, which has had dramatic effects on passenger numbers: On the non ITF lines the passenger numbers have come down with a run, but the ITF lines were able to retain the number of the passengers. On the hourly frequency ITF-East lines the passenger numbers haven't come down between 2006 and 2008, while the rest of the network has lost more than 15 percent of the passengers, and in 2010 the ITF-East lines had 5 percent more than before the introduction of ITF. The greatest development was on the ITF-West lines because in these lines the trains started to be competitors of the buses again, the passenger numbers have increased about 15 percentage points in two years after the introduction of ITF-West. In 2011 the MÁV-Start has changed its statistic system, therefore sadly the 2011 data is not comparable with the previous ones, but in 2011 the passenger numbers increased on the whole network mostly because of the increasing fuel prices, and the gap between ITF and non ITF lines got even bigger.

### 3 Future timetable developments

Since the introduction of the ITF the first time we will need to modify the structure will be in December of 2012, because the infrastructure development of the line between Budapest and Székesfehérvár and between Boba and Hodoš will be ready, and the parameters of the lines will be different, the journey time will be much shorter and the capacity of the lines will increase.

The line between Budapest and Székesfehérvár is one of the most important lines of Hungary, because it connects Budapest and three important lines which serve two regions of Transdanubia. The journey time of nonstop trains between Budapest and Székesfehérvár will cut about 20 minutes, and the capacity will increase in the most busy suburb part, because one more track will be built.

The line between Boba and Hodoš was reconstructed already few years ago, but because of the limited capacity of the Budapest-Székesfehérvár line, we couldn't modify the timetable structure, we couldn't use the new rail triangle, which can cut the journey time of the fast trains by another 15 minutes.

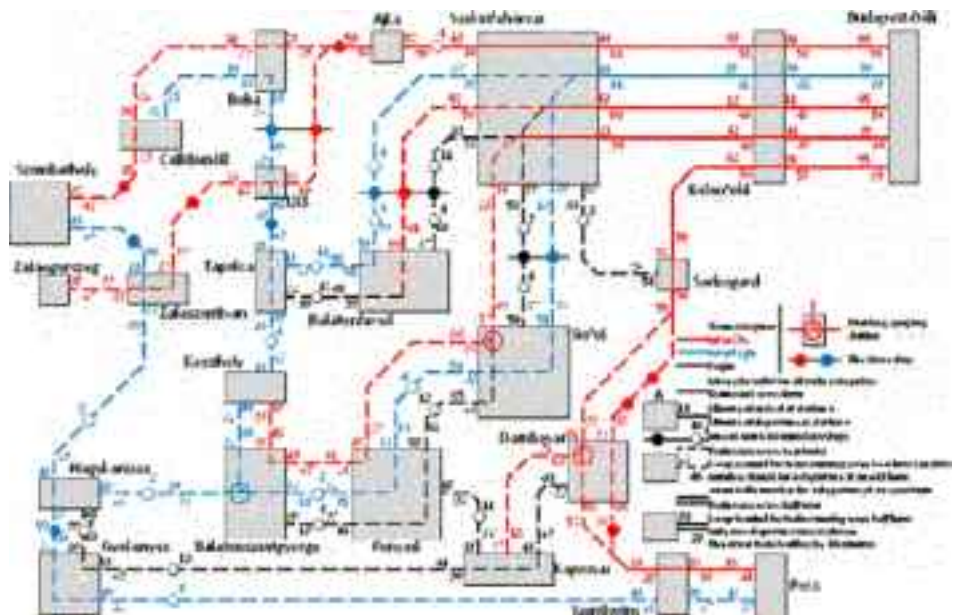

Figure 4 Timetable–map for the mid–term planned interregional ITF system at the area of Lake Balaton

### 3.1 Budapest–Székesfehérvár–Veszpém–Zalaegerszeg / Szombathely line

Since the introduction of ITF–west, there is a two hourly frequency between Budapest and Boba. The trains divide there, one of the parts drives to Zalaegerszeg and the other part to Szombathely. Dividing and coupling the trains takes about 15 minutes. According to the new structure we are planning to introduce hourly frequency between Budapest and Devecser. One of the trains will go to Zalaegerszeg by using the new railway triangle at Boba, and the other to Szombathely.

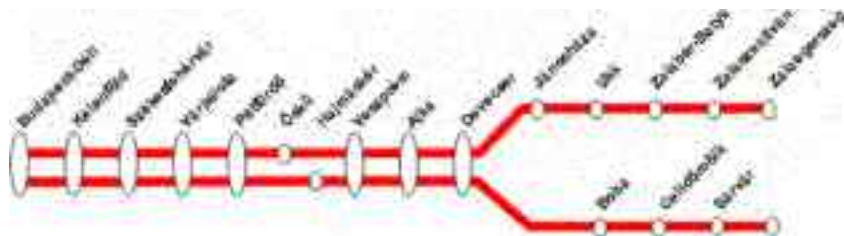

Figure 5 Stops of the planned Budapest–Szombathely and Budapest–Zalaegerszeg interregional trains

Between Budapest and Devecser the headway will be halved, and the journey time will be cut by 20 minutes from Budapest. Between Devecser and Zalaegerszeg as well as between Boba and Szombathely, the frequency stays two hourly, but the journey time is cut by more than 40 minutes.

The new structure also has hubs in Veszprém which is one the most important cities of middle Transdanubia, and in Zalaszentiván, Celldömölk and Szombathely, but the Veszprém and Celldömölk hubs will shift by 30 minutes. For the new structure we don't need more vehicles, even though the trains will run double as often, because the running and the turnaround times will be much shorter. So we will use our fleet much more efficient.



### 3.3 Other impacts of the infrastructure developments

On the line Budapest–Nagykanizsa–Gyékényes the journey time will be cut by 20 minutes, but the structure remains the same, the trains will depart 20 minutes later and arrive 20 minutes earlier at Budapest. Because of that the turnaround times will change, and we need one train set less.

## 4 Examples for timetable based infrastructure developments

The ITF is the most effective way to stop and reverse the characteristic loss of passengers in the railway sector, but its main advantage is manifested as huge cost savings in infrastructure development processes. Knowing the exact required technical details for building a competitive public transport system significantly reduces the construction costs. Development of railway infrastructure is one of the most cost-intensive investments, mainly funded by taxpayers. These circumstances make it very important that the concept of creation must be always preceded by the construction. The more detailed your concept is, the less you pay on development. Experience has shown that the most detailed plans for the future are based on the philosophy of the ITF.

### 4.1 Plans for reconstruction of suburban line Budapest–Veresegyház–Vác

The line is a quite important part of Budapest's suburb network, it was part of the ITF pilot project, as we mentioned. It has ITF timetable since more than seven years now. Since then the passenger numbers are increasing. For now it has become a quite busy line transporting 2 million passengers yearly, but its infrastructure is still very poor: it is a one track line, the trains run about 60 kph. The journey time for 49 km is 1:25 minutes. For developing the line, the original plan was to renew the tracks for 80 kph, (higher speed is just partially possible due to the alignment) and renew all the stations. After making the plans for the tracks, the designers tried to make an ITF timetable for the reconstructed infrastructure, but the journey time had become just 6 minutes shorter, because the meetings of the trains couldn't move, so the trains would have to wait for each other in middle stations, as much as the journey time got shorter before. Because of this the MÁV–Start didn't accept the plans, therefore the designers had to remake them. In this case first they made a timetable structure, and after that they checked what infrastructure parameters it requires. By that the journey time will be cut by 18 minutes, the 30 minutes frequency will be possible for both directions in the same time. For that they needed to plan two short sections, which are usable for 100 kph, and a new station where the trains could meet, but the system requires fewer tracks in two other stations.

### 4.2 Plans for reconstruction of south Balaton line

That was the first example, when due to the perfectly working ITF system timetable, the first step of the infrastructure development was designing the timetable. The south Balaton line between Székesfehérvár and Nagykanizsa is an electrified line, with one track and automatic block signal, as well as centralized traffic control. The original speed of the line was 100 kph, but nowadays trains run only about 60 kph, because of the poor condition of the rails. Since the introduction of ITF–West, there are two hourly frequency fast trains between Budapest and Balatonszentgyörgy. The trains divide there, one of the parts goes to Keszthely and the other part to Nagykanizsa. The fast trains stop at every settlement at the lake, so on that part they also provide the regional service, with relatively high passenger numbers all year long. But due to the low speed and the many stops between Budapest and Nagykanizsa, the travelling time is not even comparable with the highway, for this the trains are not competitive. During summertime the Lake Balaton is the most important holiday destination in Hungary, and due to the really good location of the stations, the trains are very popular. Apart from the regular periodic fast trains there are plenty of holiday semi-fast trains which provide direct service for the vacationers to all the stops from Budapest

and from Eastern–Hungary as well (at lake Balaton there are plenty of stops typically for recreation areas without any resident population). There are two major problems with the current timetable, the journey time is not competitive, and the direct trains are even much slower, and they are not part of the periodic system. Finding solutions for these problems was the core of designing the timetable which will be the base of infrastructure development: In the new structure the two hourly fast trains with the current stops have remained, there are periodic trains for vacationers providing direct connections and a faster express train for the most important cities like Keszthely and Fonyód. The periodic fast trains will meet each other in hubs in Siófok, which is the most important city of the south shore, and in Balatonszentgyörgy, where the lines to Nagykanizsa and Keszthely connect. This structure requires 100 kph and partially 120 kph available speed, and two short sections with double tracks, where the periodic trains can meet each other. The result will be a competitive railway line, with hubs on the right stations, providing direct services for vacationers with good journey time in all the relations.

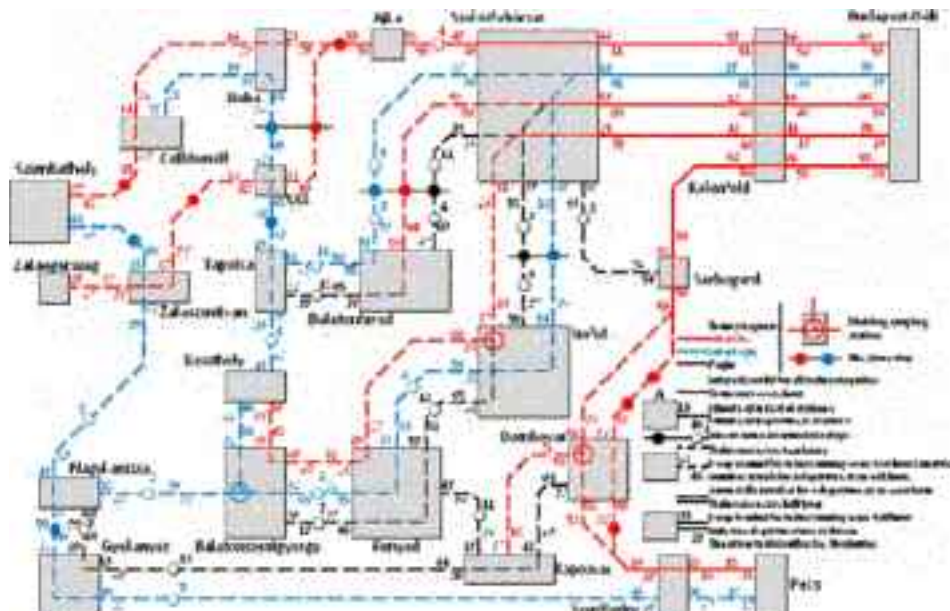
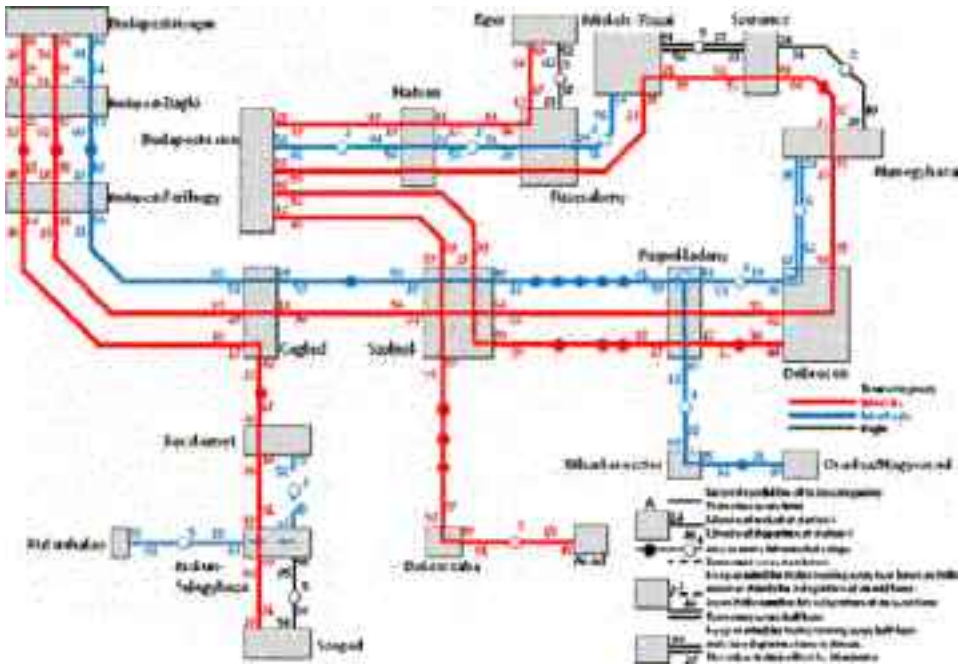

Figure 8 Timetable–map for the mid–term planned interregional ITF system at the area of Lake Balaton

### 4.3 Plans for reconstruction of Miskolc-Tiszai station

The core component of ITF is the transfer between trains especially in the hubs. To organise transfer the most comfortable way, we need to reconfigure hub stations in a transfer–friendly way on the occasion of their infrastructure development. It is very important to know exactly what the transfer time will be between any two trains and how many passengers are expected to change from one to the other. Knowing this information makes it possible to design platforms to their most proper place.

To determine the most serviceable topography of a station, we need to know the pinpoint timetable–plans for all lines leading there. If we know this we have to prepare the infrastructure according to these timetable–plans in the best possible way, but don't have to prepare the infrastructure for all possible traffic situations. This specification results in a considerable cost reduction of the infrastructure development.



**Figure 9** Timetable-map for the mid-term planned interregional ITF system of Eastern Hungary

One of the most important hubs attending the (previously introduced ITF-East) core network is Miskolc, which is the third biggest city in Hungary. This hub is planned to join 2 long-distance (hourly), 4 suburban (hourly), 3 so called tram-train – combined tram and suburban train service, which uses the railway outside, and the tram network inside the city – (half hourly) and 3 (high frequency) city-tram connections. In a conventional approach, altogether these 12 destinations would need 24 (arrival & departure) tracks to make connection between all of them. With this high number of platforms it is simply impossible to be able to guarantee acceptable transfer conditions. Furthermore, there are now only 4 platforms on the station, and in the middle of a living city it would be a desperate endeavour to expand it so much. But if we have an elaborated timetable structure, we can allocate our hub-trains not only in space but time as well.

For the new Miskolc-Tiszai station a non-conventional setting of the tracks has been planned, with through tracks on the two sides, and a specified turnaround area for the connecting trains between them. The fastest and the most comfortable way of transferring between two trains is when both of them are on the same platform. One platform has only two sides, but this topology (Fig. 9) guarantees the same platform for three trains in the same time including a through track. With an easy access to a turnaround area, it is possible for all the connecting trains to replace each other, one after the other.



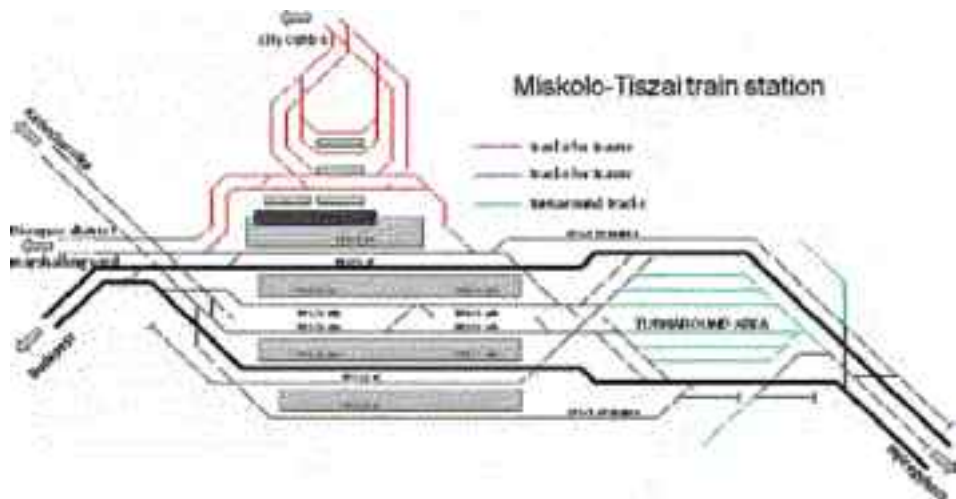

Figure 10 Topology of the planned new Miskolc train station

## 5 Conclusion

In Hungary ITF system timetables first managed to stop the loss of railway passengers, then they have become being the base of infrastructure developments, and now they are defaults in politics and in public as well. Trains running in periodic schedule is just like gravitation, it's normal. There are many examples when schools, workplaces or private attractions started to go by the periodic timetable. But maybe the most important advantage of ITF are the huge cost savings in infrastructure development processes, which means that an economy can use its sources much more efficiently.

## References

- [1] Borza, v. - Kormányos, L. – Vincze, B.: New regular interval timetables in operation on the suburban line of the Hungarian State Railways (ŽEL 2005, Žilina 2005, p. 57-64.);
- [2] Kormányos, L. – Vincze, B.: Introduction of the periodic timetable on the Hungarian railway network - Etappe 1., EURNEX-ZEL 2007, 30-31;
- [3] Source of the number of passengers: 'SZITA' (sales database of MÁV-START Co.).

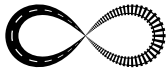

## TECHNICAL AND TECHNOLOGICAL PRECONDITIONS FOR IMPLEMENTATION OF INTEGRATED TIMETABLE IN REGIONAL PASSENGER TRANSPORT WITH THE REPUBLIC OF SLOVENIA

Tomislav Josip Mlinarić, Tihomir Pleša, Ivica Ljubaj

*University of Zagreb, Faculty of Transport and Traffic Sciences, Zagreb, Croatia*

### Abstract

The technical and technological aspects of introducing regional passenger transport refer primarily to the introduction and improvement of integrated timetable. In the Republic of Croatia and its immediate surroundings this problem has been tackled primarily in the host countries. The goal of this work is to indicate the possibility of regional passenger transport on the territory of the Republic of Slovenia and the Republic of Croatia. In order to use these possibilities it is necessary to determine all the technical and technological parameters of rail transport, based on which such a concept would be implemented in a proper way.

*Keywords: regional passenger transport, integrated timetable, rail transport*

### 1 Introduction

Since the Republic of Croatia is about to join the European Union, this means formal disappearance of the borders between Croatia and the permanent EU member countries. In order to use the advantage of this political integration, it is necessary to organize transport in a smarter way and to improve the cooperation between the neighbouring railway administrations. The Republic of Croatia, as well as the Republic of Slovenia can become more efficient and more accessible to all the interested transport users by reorganizing rail passenger transport. The integrated passenger transport as a concept is very rewarding for the implementation and adaptation on the existing railway networks and conditions of transport organization on them. The integration means organization of the parts which act harmoniously in achieving joint objectives, i.e. such harmony acting as a system. To make the concept successfully operational, some pre-conditions have to be met, and the most important of these are the harmonization of the timetables (in arrival and departure). Also, the usage of a unique ticket simplifies the entire technological process of transport and transparent control of revenues and costs. However, in order for this transport concept to come to life it is necessary to research in detail the transport demand and the habits and needs of the target group of users.

In order to apply the concept of integrated transport, this paper has studied the possibilities of providing such services in regional transport between the Republic of Croatia and the Republic of Slovenia. The proposed concept has been developed for the network of the existing lines between the two countries which includes:

- 1 railway stations Savski Marof – Dobova;
- 2 network sections in Croatia around railway station Čakovec as start-terminal hub station;
- 3 sections of railway network in Slovenia around railway station Ormož as start-terminal hub station.

The implementation of such concept would thus encompass the existing railway lines, and they would be used to organize the traffic based on interoperability, achieving maximum shortening of passenger composition turnaround time and maximum usage of its capacities. The technical preconditions for such a concept on the two mentioned railway networks have been maximally satisfied.

## 2 Research of transport demand

When considering regional passenger transport on the HŽ lines network in railway traffic the average transport route ranged from 32km in 2001 to 48.2km in 2010. It is also interesting to note the range of the average transport route in interurban traffic for the same period of time, from 47km to 55km. This may lead to the conclusion that the total average transport route in the system of the Croatian Railways is extremely low, regardless whether it refers to internal both interurban, and urban–suburban and international transport of passengers. Obviously, this level of service can be seen in the number of carried passengers in regional transport on the network of railway lines of the Croatian Railways system (Table 1).

**Table 1** Realization of transport and revenues in regional transport of the Croatian Railways system (in 000)  
– Estimate of regional traffic excluding distance traffic

YEAR	2005	2006	2007	2008	2009	2010
PASSENGERS	14,362	14,485	14,351	14,176	14,690	14,537
PKM	619,000	629,000	603,000	675,000	690,000	657,000
REVENUE	157,300	167,000	174,400	186,100	178,100	175,000

The reasons for such a low level of service in regional passenger transport on the network of HŽ railway lines, i.e. obvious stagnation in the total number of carried passengers lie in the following facts:

- 1 insufficient (or better to say technologically inefficient) investments in rail infrastructure which is in the segment of passenger transport service in the function of target network;
- 2 insufficient investments in repair and modernisation of the rolling stock for the passenger transport requirements (which is owned by HŽ – Passenger Transport Ltd. Company), and
- 3 poor and technologically unsustainable model of the organization of passenger transport service provider within the HŽ Holding structure which requires radical structural changes and a good program of reorganization and restructuring.

Should the necessary reforms and good investment cycle in this sector of passenger transport in the coming period fail to take place, one may expect a certain growing trend in the number of carried passengers, but with a very low rate of growth. The part of regional transport that refers to the topic of this paper is related to the railway stations Varaždin and Zabok for which the traffic forecast is presented in Table 2.

**Table 2** Forecast of regional transport per railway stations

RAILWAY STATIONS	2006	2010	2015	2020	2025	2028
Varaždin	453,214	571,043	711,623	824,967	1,052,890	1,117,335
Zabok	468,888	723,276	901,333	1,044,893	1,333,577	1,415,203
TOTAL	922,102	1,294,319	1,612,957	1,869,859	2,386,467	2,532,538

### 3 Vehicles for integrated public passenger transport between Slovenia and Croatia

In order to respond to modern transport user requirements and transport demand which is generated on these sections, it is necessary to use adequate transport means to serve the respective region. Since regarding the electrification of the considered section of the network there is a case of two supply systems, and certain sections that have not been electrified, the use of Diesel multiple units (hereinafter DMU) is proposed for this service of integrated passenger transport.

One of the possible solutions is a low-floor Diesel multiple unit developed by the Gredelj Company, which satisfies the advanced requirements and conditions of transport required of them. The train of 7022 series for regional traffic is low-floor, with floor height of only 570/600/875 mm and with 209 seats and 201 standing places and with maximum velocity of 160km/h. Such vehicle is both regarding design and performances adapted to target organization of passenger transport, and its advantages in the proposed organization of traffic will have multiple effects. Because of technical compatibility of the observed networks the vehicle can be used for this type of transport without any special modifications. Naturally, it is necessary to insure adequate education of the train staff that would serve such a technological transport process.

Also, according to another proposed variant of integrating passenger transport on this part of network, the possibility of using electric multiple units can be also taken into consideration. One of the possible solutions is the low-floor electric multiple unit developed by the Končar Company, which satisfies the advanced requirements and conditions of transport required of them. The train of series 6112 for regional transport is low-floor, with floor height of only 600mm and with 212 seats and 220 standing places, and with maximum velocity of 160km/h. Such a vehicle is regarding design and performances adapted to target organization of passenger transport and its advantages will have multiple effects in the proposed organization of traffic.

### 4 Analysis of technical and technological parameters of the proposed section of rail network for the implementation of integrated timetable

Since the Croatian Railways have determined in their strategic and operative plans the development concept of the urban-suburban transport and regional transport on their part of the network (Figure 1) the proposed organization of crossborder integrated passenger transport has to recognize the proposed approach. In this concrete case it would be the integration of urban-suburban transport of the city of Zagreb and the regional transport on relation Zidani Most-state border-Savski Marof-Zagreb-Dugo Selo.



Figure 1 Schematic presentation of observed Zagreb ring sections

Two concepts are proposed on the considered section, i.e. two variants of transport organization. These variants have been determined based on the length of the considered relation, transportation conditions on the respective relation and determination of the turnaround stations that would be the start–terminal travel points of the used passenger compositions.

#### 4.1 Proposal of passenger transport integration on Zagreb (Dugo Selo)–Dobova–Zidani Most (Sevnica) relation

In the first variant the idea is that the travel section is Zagreb – Zidani Most with stopping in Zaprešić, Savski Marof and Dobova. It is namely at the stations Zaprešić and Savski Marof that the railway lines fork towards other important railway stations on the network, and as such represent important points in further integration of rail transport (at the railway station Dobova which is currently a border station the exchange of the train staff may take place). According to current conditions of the usage level of infrastructure the travel time from the station Zagreb Main Railway Station to the railway station Zidani most is 83 minutes, which means that the turnaround of one composition in one direction would be approximately one hour and 30 minutes. Since it is a double track section between terminal stations there are no special technological restrictions for such traffic organization. Figure 2 shows the schematic presentation of the composition turnaround and individual travel times i.e. stopping times at certain traffic places of work.

The second variant refers to Dugo Selo–Sevnica relation. On this relation the railway station Dugo Selo is at the same time the terminal railway station of the urban–suburban transport of Zagreb, and from the railway station Sevnica the railway line forks towards Zidani Most (Maribor, i.e. Ljubljana). According to the current conditions of the usage level of the infrastructure the travel time on this relation is 83 minutes, and the turnaround in one direction would amount to ca. one hour and 30 minutes. The proposed organization of traffic is presented by a scheme in Figure 3.



Figure 2 Schematic presentation of section Zagreb – Zidani most with individual times



Figure 3 Schematic presentation of Dugo Selo–Sevnica section with individual times

As possible sub–variant of transport organization on the current relation in case electric multiple units (EMU) were used for passenger transport the following solution is proposed. From railway station Dugo Selo via Zagreb to Dobova the EMU would be used for 25kV AC system, and in Dobova the passengers would change to EMU with 3kV DC system.

The change of passengers from one train to another would be organized at the same platform at the railway station Dobova, so that the passengers could change safely and fast from one train to another. Such approach requires adaptation of the overhead contact line from both

sides of the platform. In that case the travel time of the railway station Zagreb and Dobova would be 34 minutes, and with stopping times at turnaround stations the turnaround would take 45 minutes (Figure 4).



Figure 5 Schematic presentation of Zagreb–Dobova section with individual times

In case a clock–face timetable were used with an interval of 60 minutes as planned, for the first two cases in order to maintain the interval three trains would be necessary, whereas in the third case (change of train at the railway station of the traction system change two trains would be necessary).

#### 4.2 Čakovec – Ormož section

If such a concept were implemented on the Čakovec – Ormož section, the travel times and the turnaround of compositions have been established as well. The reason is because the railway stations Čakovec and Ormož are hub stations from which the railway lines fork into several different directions and these stations are suitable as points of integration. Figure 5 shows the organisation of traffic of the planned DMU compositions between these two hub stations.

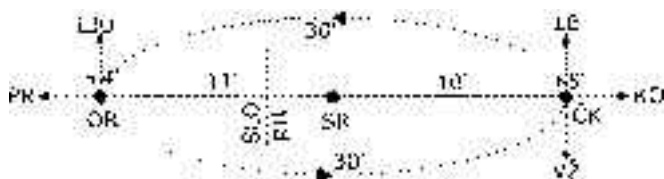

Figure 6 Schematic presentation of Čakovec – Ormož section with individual times

An interval of 60 minutes would also be used in this concept, and to maintain this interval only one diesel multiple unit would be necessary, which would operate between Čakovec and Ormož.

## 5 Conclusion

Since the Republic of Croatia is soon to become an EU member country, the logical and foreseeable further step is the connection of the neighbouring border regions, which are already well connected regarding traffic. This connection should be based on the concept of integrated public passenger transport, since in this way the technical and technological drawbacks of the classical transport organization are avoided.

The integrated passenger transport features many advantages, and the most important ones are fast, efficient and high-quality transport with great savings, first of all of time (since waiting is eliminated or reduced to a minimum), and at the same time the efficiency of all the transport means is increased, thus automatically reducing the costs.

Also, since the studied sections of the networks of HŽ and sŽ systems are to the greatest extent technically and technologically compatible, the use of a joint rolling stock is possible in providing this service.

The criteria according to which this integration of the passenger transport is proposed refer to the duration of the turnaround of the composition in regional passenger transport and the role and importance at the official places of work on the current network that would be in the function of providing this type of service.

This type of approach results in a series of positive effects, first of all the existing capacities of the railway infrastructure could be additionally used. The use of railcars for this purpose as well would substantially increase their productivity and efficiency. Finally, there would be additional promotion of such type of service of rail transport thus significantly increasing the competitiveness of rail system on the transport service market. Such integration on the market of transport services would create the preconditions to think about the foundation of joint operators in this market segment.

## References

- [1] Trans-European Conventional Rail System, Subsystem Rolling Stock, TSI 'Locomotives and Passenger RST', European Railway Agency, Interoperability Unit, Bruxelles, 2008
- [2] Hrvatske željeznice – Program modernizacije prijevoznih kapaciteta u razdoblju od 2010.-2012. godine (Croatian Railways – Modernization Program of Transport Capacities in the Period from 2010 – 2012), Hrvatske željeznice (Croatian Railways), Zagreb, 2010
- [3] Mlinarić, T.J., Nikšić, M., Brkić, M.: Implementation of Fleet Management in Train Traction, Traffic and Transportation, Vol. 20, Zagreb, 2008
- [4] Plan investicija prijevoznih kapaciteta društava HŽ Holdinga (Investment Plan of Transport Capacities of HŽ Holding Societies), HŽ Holding, Zagreb, February 2011
- [5] Studija razvoja i unapređenja kvalitete usluga gradsko-prigradskog željezničkog prijevoza putnika grada Zagreba i okolnih županija (Study of Development and Improvement of Service Quality of Urban-Suburban Rail Transport of Passengers of the City of Zagreb and the Surrounding Counties), Inženjerski biro Convena Consulting, Zagreb, 2011
- [6] Istraživanje prometne potražnje tržišta željezničkih transportnih usluga u Republici Hrvatskoj i okruženju – case study: potreba za elektro – vučnim vozilima (Study of Transport Demand of Railway Transport Services in the Republic of Croatia and the surrounding – case study: need for electrical traction vehicles), Faculty of Transport and Traffic Sciences, Zagreb, September 2010

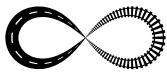

## TECHNICAL AND TECHNOLOGICAL PRECONDITIONS FOR IMPLEMENTATION OF THE INTEGRATED TIMETABLE IN REGIONAL PASSENGER TRANSPORT IN THE REPUBLIC OF HUNGARY

Tomislav Josip Mlinarić, Denis Lauš, Melkior Vilić

*University of Zagreb, Faculty of Transport and Traffic Sciences, Croatia*

### Abstract

The technological aspect of introducing regional passenger transport refers primarily to the implementation of integrated timetable. This problem had been tackled both in the Republic of Croatia and in her immediate surroundings (Hungary, Slovenia, etc.) until now only within the frames of individual networks. Soon, when the Republic of Croatia joins the European Union the organization of passenger transport in the border region in regional passenger transport will become a joint issue as well as the possibility that needs to be taken advantage of as soon as possible in a high-quality manner. The objective of this paper is to indicate the possibility of integrating the regional passenger transport in the Republic of Hungary and the Republic of Croatia at minimal expenditure of financial and material means. For this segment of common transport market to be used in the best way, it is necessary to determine the crucial technical and technological parameters of rail transport, which would be used to implement such a concept in a proper manner.

*Keywords: regional passenger transport; integrated timetable; technological parameters*

### 1 Introduction

One of the basic activities of the rail system is to provide the transport service in passenger traffic. This service is public, which means that it is intended for all the citizens under the same conditions. This means that anyone who wants to use it, can acquire an adequate transport document and thus become a potential user of the service. Public passenger transport, apart from being accessible to anyone who needs transport, features also some advantages over the transport by passenger car, i.e. over the personal transport such as e.g.: public transport generates much less pollution per carried passenger; public transport consumes much less propelling energy per carried passenger; public transport is several times safer than personal transport; public transport occupies much less space than personal transport (long queues of cars, parking lots, etc.); public transport increases the mobility of citizens who gravitate to this transport system, i.e. assures a higher standard of living. The mentioned advantages are the main reason why the railway transport will have in the near future an even greater significance than before, and especially after the accession of the Republic of Croatia into the European Union. This is precisely the incentive for the carried out research presented in this paper. The accession of the Republic of Croatia in the European Union, namely, means elimination of the border traffic on some sections of the railway network (of the Croatian Railways), and practically the creation of new regional sections. This paper will briefly present the idea of how and under which conditions, first of all the technical and technological ones, is possible to establish a high-quality regional passenger transport on some sections. This



refers primarily to the region along the border of the Republic of Croatia and the Republic of Hungary, and the idea of the organization of regional transport on the Zagreb–Koprivnica–Kaposvar section will be presented.

## 2 Study on transport demand

In regional passenger transport on the HŽ railway network the average travel route ranged from 32km in 2001 to 48.2km in 2010. In interurban passenger traffic on the network of HŽ railway lines the average travel route for the same period ranged from 47km to 55km. This leads to the conclusion that the total average transport route in the system of the Croatian Railways is unacceptably low, regardless of whether it refers to internal both interurban and urban–suburban transport of passengers. Such level of service is seen in the number of carried passengers in regional transport on the network of railway lines of the Croatian Railways system (Table 1).

**Table 1** Realization of transport and revenues in regional transport system of HŽ

YEAR	2005	2006	2007	2008	2009	2010
PASSENGERS	14,362	14,485	14,351	14,176	14,690	14,537
PKM	619,000	629,000	603,000	675,000	690,000	657,000
REVENUE	157,300	167,000	174,400	186,100	178,100	175,000

The reasons for such low level of service in regional passenger transport on the mentioned network, i.e. obvious stagnation of the total number of carried passengers lies in the following facts:

- 1 insufficient (technologically inefficient) investments in rail infrastructure in the function of target network;
- 2 insufficient investments in repair and modernisation of the rolling stock for the passenger transport requirements, and
- 3 technologically unsustainable model of organization of passenger transport service providers which requires radical structural changes and a good restructuring program.

If high-quality reforms and a sustainable investment cycle in this sector of passenger transport fail to be realized in the coming period, a certain growing trend of the carried passengers can be expected, but with a very low rate of growth. The part of regional transport that refers to the topic of this paper is related to the railway stations Križevci, Koprivnica and Vrbovec for which the traffic forecast is presented in Table 2.

**Table 2** Forecast of regional transport per railway stations

RAILWAY STATIONS	2006	2010	2015	2020	2025	2028
Križevci	189,877	209,132	229,767	247,524	286,948	295,643
Koprivnica	364,517	367,227	405,448	436,783	506,351	521,694
Vrbovec	226,201	272,572	300,942	324,199	375,836	387,224
TOTAL	780,595	848,931	936,157	1,008,506	1,169,135	1,204,561

The expected increase in the number of passengers according to the obtained results, if the necessary investments into infrastructure fail to be realized, according to the obtained results in the period from 2010 to 2015 per rate of 2%, from 2015 – 2020 it is 1.5%, from 2020 – 2025 it is 3%, and further it would be at a rate of 1% with somewhat lower expectations, if the necessary investment into infrastructure fail to be realized.

### 3 Integrated public passenger transport

Integration means organization of parts (elements) into a whole (structure) which acts harmoniously in the existence of common goals i.e. that which features harmony between single and common goals.

Integration in passenger transport plays a very significant role since its definition means organization of certain elements into a whole which acts towards achieving common goals. In other words, integration connects all the elements that participate in the transport process (all the transport subsystems) into a unique system (integrated public passenger transport) which leads towards a better, more efficient, faster and safer passenger transport from origin to destination. In this way every traffic subsystem can make maximum use of its advantages but in integration with others who participate in transport realization.

It is precisely for this reason that eight railway stations have been selected in traffic that would be organized on the Zagreb–Koprivnica–Kaposvar section (four on the railway lines of the Croatian Railways and four stations on the railway lines of the Hungarian Railways). These are the stations in which another new line forks so that the passengers have a direct connection towards their destinations or they can change to another transport subsystem in order to arrive to their destinations.

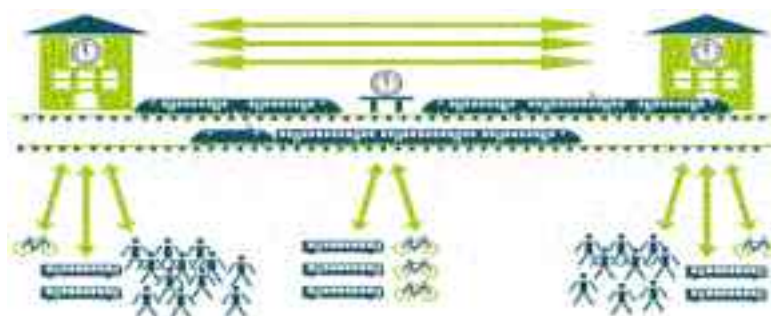
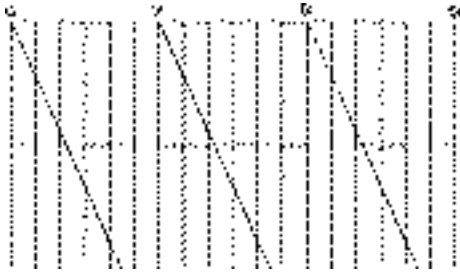

Figure 1 Scheme of integrated passenger transport

#### 3.1 Introduction of a clock-face timetable

Since passenger transport has the advantage in railway transport over cargo, more attention should be paid to its performance, i.e. more care should be taken of its organization in order to make it maximally punctual and efficient, and so that it meets the passenger transport demands. In order to achieve this it is necessary to design such a timetable in which trains from the starting stations (Zagreb, Koprivnica, Kaposvar) depart and arrive into them in regular time intervals, and this type of timetable is called a clock-face timetable, since the trains depart and arrive in equal time intervals (of 10, 15, 20, 30, 60 or more minutes). On this section of the railway line a clock-face timetable will be introduced with time intervals of 90 minutes (Figure 2), where four electric multiple unit compositions will be used for the total organization of passenger transport, and the time of departure of the first train will be determined after a market survey, i.e. when it is established at which time the passengers require trains.



**Figure 2** Clock-face timetable graph

Such integrated timetable features mainly two significant advantages and these are: passengers' satisfaction due to easier coping with the timetable, efficiency of the clock-face timetable.

**Table 3** A forecast of travel times

Section	Current travel time	Target travel time
Zagreb – Dugo Selo	25 min	15 min
Dugo Selo – Križevci	26 min	15 min
Križevci – Koprivnica	44 min	30 min
Σ	95 min	60 min

Regarding the planned capacity of the compositions in the clock-face timetable the maximum passenger capacity would amount to 62,208 passengers daily, under the condition that all the seats and all the standing places are occupied.

## 4 Rolling stock and transport capacities

One of the basic elements for the realization of the determined traffic demand and organization of regional transport are the multiple unit vehicles that have to be interoperable, i.e. usable on both rail networks. Therefore, one of the proposed possibilities are the electric multiple units for regional transport that have been developed for the HŽ system requirements by the companies Končar and TŽV–Gredelj. This is a four-unit composition which is intended for regional passenger transport, with two motor units and two central modules. The end modules are the driving modules with driver's cabs. On one end the driving module rests on a bogie, and the other end rests on the supporting inter-bogie at the joint of two modules. The driving equipment of the driving module is located in a case outside the driving bogie. The rest of the space in the case is the low-floor passenger space (floor height at 600mm above rails, and maximally 850mm above free frames, allowing entry from a platform of 200, 350 or 500mm height).

The driving module is equipped with electromotive drive of 1,050kW installed power with two traction electric motors. The module is fitted with a pair of double doors 1,300mm wide, and seats of higher comfort adapted to regional transport. The central modules are exclusively passenger modules. They are set between the end modules with driver's cabs, and each relies on two inter-bogies on the joints of two modules. The modules are completely low-floor (floor height at 600mm above rails and maximally 850mm above free frames). Each module is equipped with a pair of double doors, and seats of higher comfort adapted to regional transport. The passenger cabins of the modules are connected by connecting tunnels and thus form a unique space without partitions. The floor in the connecting tunnels is at a height of maximally 850mm, and transitions from one level to another are designed with slightly inclined ramps (of 1:8 gradient). The passenger cabin is fitted with partly transparent partitions that visually close the space,

and protect the passengers against cold air when the doors are opened. The seats are mostly designed as double-seats, except in the part which is intended for disabled passengers in wheelchairs, and parents with children in baby carriages, where single seats and folding seats are installed. Part of the space is equipped with bicycle hangers. EMU operates so that it allows connecting of three EMUs in one set by means of automatic couplings.

## 5 Possibilities of organizing passenger transport in regional traffic on the observed Zagreb–Koprivnica–Kaposvar line

By analyzing the condition of the railway lines that encompasses the existing organization of operation on the mentioned section of the network the most important thing is to determine the conditions of traffic reorganization. The concept of the proposed line reorganization is based on the following assumptions: new categorization of local passenger trains and the network, and the travelling method of single train category; minimization of turnaround interval by determining the railway station of composition turnaround; integration of such organization of regional passenger transport into the organization of suburban trains of the major cities of RH in a unique technological system.

The realization of this concept has to show, in relation to the existing condition, that it is possible without any investments into the existing infrastructure to increase the available transport capacity and to ensure the users' service of higher quality. The concept of new passenger transport organization in this part of the network means different activity measures on each line section, and as the criterion for the proposed concept in Figure 3 the target structure of the railway station, turnaround and the respective travel times is presented. Because of the new method of participation in the method and costs of passenger transport, the RPP trains participate only in RPP traffic with emphasis on stopping at all the planned stops, and for them the tickets for the combined passenger transport are valid. Also, due to the integration of GPP rail transport other trains would disturb the integrated timetables and the integrated technological process of passenger transport in general.

Another criterion is the distance between turnaround stations and the travel time, which should never exceed the maximally planned ones (according to Figure 5).



Figure 3 Time intervals as condition of terminal stations

At the same time the proposed concept of organizing the lines or regional trains is based on two basic assumptions: new categorization of regional passenger trains and network and the operation method of single train category; minimization of turnaround interval by determining the composition turnaround stations.

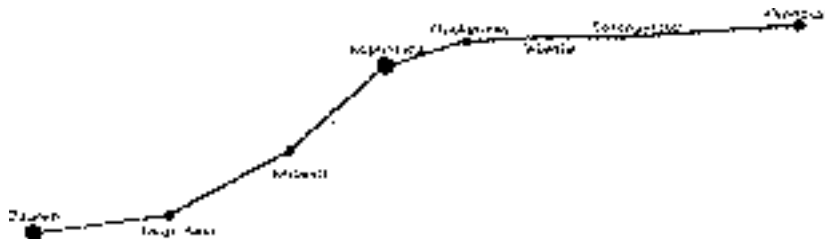

Figure 4 Graphic presentation of a section of regional passenger transport network

## 5.1 Modification of the bus timetable

In previous analyses it has been determined that the bus transport is not sufficiently harmonized with rail transport, and interventions are necessary to solve this issue. The bus timetable should be designed so that bus arrivals are adapted to the rail timetable, so that the buses arrive 10 or maximally 15 minutes earlier to the integration point, to allow passengers fast and easy change of the transport subsystem and trip continuation, and leave to end destinations 10 or maximally 15 minutes after train departure so that the passengers would not lose too much time on waiting and travelling.

First those bus lines which are used by the largest number of passengers should be adapted, since these are precisely the lines that are the basis of integration. In order to achieve fastest possible passenger exchange, apart from harmonization of lines, timetables and integration points, it is very important that the passengers have the possibility of using all the transport modes during their trips with only one ticket that would be valid in all the transport means used on their trips, from the origin to destination. One of the simple solutions is a card with a microchip containing user's data, and special devices that the attendants i.e. the staff or the vehicles of a certain transport mode would be fitted with. In this way the data would be read in a fast and simple way, and the tickets would be charged and controlled. If all the aforementioned is realized, the regional passenger trains will perform their basic functions: integrated passenger transport with other regional transport modes, operating from start to terminal regional railway stations in time intervals of 90' – 120' (Figure 5 and Figure 6).

## 6 Conclusion

Until now, the railway traffic in the Republic of Croatia had not considered the possible integration of regional passenger transport with the Republic of Hungary in those regions where there is a certain need for that. Soon, when the Republic of Croatia joins the European Union the organization of passenger transport (regional) in the border region will become a joint possibility for all the railways whose networks are in the region.

It is certainly necessary to consider the transport capacities that would make such a service possible. In this sense, HŽ has already undertaken certain steps. Since the current HŽ – Passenger Transport rolling stock does not satisfy present transport requirements, and regarding the expected growth of this segment of rail transport, in cooperation with the companies Končar and TŽV Gredelj a serial production of electric multiple units has been started, which have technical characteristics that are interoperable for the Croatian and for the Hungarian railway network.

Apart from the issue of the rolling stock on the observed network sections there is also the issue of the usage condition of the railway infrastructure, which affects especially the neatness and comfort of passenger transport. In this sense both countries, and first of all the Republic of Croatia should make additional efforts, the more so, since the train running velocities (commercial and technical) on the main railway lines of the Croatian Railways are getting lower every year.

Finally, taking into consideration all that has been said, it may be concluded that the modifications in this sector of railway traffic are inevitable as well, and that they will have to take place really soon. The technological solutions that have been provided in this paper will soon have to be implemented on the entire railway network of the Republic of Croatia. The offered solutions are very practical and very easy to implemented due to great similarities in the method of traffic flows in the earlier mentioned countries and it is already now necessary to make the preparations so that the changes could be implemented with as few problems as possible and in order to achieve maximum efficiency in operation.

## References

- [1] Trans-European Conventional Rail System, Subsystem Rolling Stock, TSI "Locomotives and Passenger RST", European Railway Agency, Interoperability Unit, Bruxelles, 2008
- [2] Mlinarić, T.J., Nikšić, M., Brkić, M.: Implementation of Fleet Management in Train Traction, Traffic and Transportation, Vol. 20, Zagreb, 2008
- [3] Studija razvoja i unapređenja kvalitete usluga gradsko-prigradskog željezničkog prijevoza putnika grada Zagreba i okolnih županija, (Study of Development and Improvement of Service Quality of Urban-Suburban Rail Transport of Passengers of the City of Zagreb and the Surrounding Counties), Engineering bureau Convena Consulting, Zagreb, 2011
- [4] Istraživanje prometne potražnje tržišta željezničkih transportnih usluga u Republici Hrvatskoj i okruženju – case study: potreba za elektro – vučnim vozilima, (Study of Transport Demand of Railway Transport Services in the Republic of Croatia and the surrounding – case study: need for electrical traction vehicles), Faculty of Transport and Traffic Sciences, Zagreb, September 2010



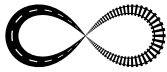

# INTEGRATED PERIODIC TIMETABLE SCHEDULING – TOWARDS AN INTEGRATED TIMETABLE ACROSS CENTRAL EUROPE

**Stefan Walter**

*Institute for Railway Engineering and Transport Economy,  
Graz University of Technology, Austria*

## Abstract

The integrated periodic timetable (ITF) is widely seen to be the most economical approach to serve the needs of Central European settlement structures with relatively short distances between rather small urban areas, whereas high-speed lines are better suited for long distances between large metropolitan areas. Many countries are about to start or have already started installing ITF across their railway networks. Others are running either regional networks or single lines in periodic timetables. Infrastructure development in these countries is more and more based upon the needs of ITF compliant railway operation. Furthermore, the latest review of TEN-R no longer talks of (high-speed) lines, but of (integrated) networks.

The growing number of different European networks that follow ITF principles increases the demand for a multilateral, systematic approach towards international timetable coordination as well as infrastructure development to avoid incompatibilities of both timetables and infrastructural measures between the highly interlinked Central European countries.

Based upon several previous studies dealing with both the theoretical and especially mathematical principles as well as the practical application of ITF and ITF compliant infrastructure development, a systematic approach to a supra-regional integrated timetable is presented. It shows that infrastructure investment is substantially more effective if it follows a systematic and therefore ITF based operational concept. Especially the relatively small sizes of countries in the central and South-Eastern European area lead to a high level of mutual interdependency between current timetable development and future national infrastructure projects. We should therefore consider the forthcoming sizeable investments in railway infrastructure in a multilateral context to identify potential problems, aimed at taking full advantage of a future pan-European integrated timetable.

*Keywords: railway, passenger transport, ITF, international integrated timetable, periodic timetable*

## 1 Introduction

In recent years, countries across the continent have carried out considerable investments in railway infrastructure as well as in timetable improvements, both in travel times and in the quantity of the offer. Two major railway operation concepts have emerged, Point-to-Point High Speed Traffic and the Integrated Periodic Timetable (ITF). Looking at Central Europe, we explore the main aspects of these concepts and examine their adequacy for Central Europe. Due to the highly interlinked character of the countries, we use an international approach, so to indicate the future direction of European Passenger Transport.



## 2 Project area

For this study, central and South–Eastern Europe is considered as the project area. This comprises the Czech Republic, Slovakia, Austria, Hungary, Slovenia, Croatia, Bosnia–Herzegovina and Serbia.



Figure 1 Project Area.

These countries share several similarities: Relatively small towns, one large capital city, short distances in between these towns and population densities between 80 and 130 persons per square kilometre.

## 3 Current concepts of railway operation

Thus far, two concepts of how to plan and operate a railway network have proved successful and serve as long–term goals: Point–to–Point High Speed Traffic and the Integrated Periodic Timetable.

### 3.1 Point to point high speed traffic

The main goal of the first High Speed Lines in Japan and then in France was to interlink densely populated agglomerations with each other. These links have the potential to justify both large scale investments in infrastructure and single–purpose Point–to–Point Traffic without integrated connections to other lines. The Tokaido Shinkansen in Japan connects a population of more than 80 million inhabitants, located in cities on average 100 kilometres apart. The LGV Sud–Est in France connects Greater Paris with more than 10 Million inhabitants on one end and cities with together over 10 million inhabitants on the other ends, each between 300 and 500 kilometres from Paris. Since then, this kind of railway operation model has been extended to other countries, always connecting large agglomerations [1].

The basic principle in Point to Point High Speed Traffic operation is that trips along the line can be considered stand–alone without connections to be considered systematically. Branches, if necessary, are served as direct trips diverging from the main line without further inferring with other routes.

The advantage of this concept is that only the demand along the route needs consideration in the planning process, resulting in very little excess capacity. Furthermore, any infrastructure improvement, no matter how extensive, directly leads to reduced travel times and an improved service.

However, this kind of operational concept is dependent on large agglomerations and sizeable distances (between 300 to 500 kilometres). This means that the population along the line needs to generate enough potential to allow for a dense timetable. This also applies for the aforementioned branch lines, so that connections to agglomerations off the main line also hold enough potential for a reasonable amount of direct connections.

### 3.2 The integrated periodic timetable

Besides the Netherlands, which put the first network-wide integrated timetable into service in the 1930s, Switzerland is perhaps the most commonly known country for its widespread implementation of an ITF scheme. Switzerland is recognised for strictly basing infrastructure improvements upon the needs of an ITF. It is for this reason, that Switzerland features a mixture of high speed and low speed sections even on main lines, depending upon the travel time necessities of the integrated timetable. Several countries such as Austria, Hungary and the Czech Republic have since followed this example [2].

The main key of this type of concept is the principle of hubs, where connections within the network meet at the same time to allow multi-directional changes for passengers. This hub structure requires ride times that are multiples of half the system interval (multiples of 30 minutes for systems with hourly services) between the hubs as well as multiples of the interval (usually multiples of 60 minutes) along any loop within the network. Therefore, the primary aim of infrastructure improvements is to reach these required ride times.

The major difference to Point-to-Point traffic lies in the consideration of the network rather than isolated lines. Wherever the potential is not concentrated along a line, is too low to allow for point-to-point connections only and/or spread out within small distances (less than 300 kilometres), the focus needs to be on how to organise the network as a whole. Travel time improvements are achieved by an adjustment of the inter-hub ride time, thus optimising the changes at hubs.

Approaching the high degree of complexity in integrated timetable planning must be systematic: Every change on individual lines might potentially affect large areas of the system. The combination of these system dependencies together with market demand and capacity restraints along the line leads to the necessity of simultaneously planning on several levels, from infrastructure up to vehicles.

## **4 Prerequisites for increasing railway market share**

The main aim of any railway service improvement is an increased market share. The railway system is mass transportation, therefore dependent on several prerequisites. Successful railway systems must feature a combination of at least two of the following conditions: distances, masses of people and a network.

### **4.1 Distances**

Compared to road traffic, railways feature a longer access time to the system, thus the market share of railway traffic will be higher for distances where the higher travelling speed will level out against the shorter access time and longer travel time of cars, until eventually air traffic becomes more attractive for very long distances. Generally speaking, we can consider distances between 50 and 500 kilometres relevant for a high market share of railway traffic. [1, 2].

### **4.2 Masses of people**

The most commonly stated advantage of railway traffic is the ability to move masses of people. This is identified in commuter rail systems all over the world. Masses of people typically occur around agglomerations, but this does not automatically imply that railway traffic outside agglomerations will be unsuccessful – if potentials along a line are bundled towards hubs with connections in all directions, there will be considerably more passengers, justifying railway traffic also outside agglomerations. This, however, is only possible with a hub structure, which implies an integrated timetable [3].

**4.3 A network**

Another prerequisite to increase the market share of railway traffic is the existence of a network. Addressing a network as such is only possible with an integrated timetable, thus allowing attractive connections in the network, including changes. A network therefore not only incorporates different railway products, but also buses, light rail and urban transport. This also automatically implies a hub structure, so that potentials are bundled along the connecting lines [3].

**5 Suitability of railway operation concepts in Central Europe**

As explained, the Central European countries considered in this study share most structural attributes. Considering these, none of these countries features relevant distances for high-speed traffic, nor is there relevant agglomerations that justify point-to-point traffic. Taking Mairhofer's gravitational approach [1], the potential for high-speed Point-to-Point traffic within an area is calculated as the sum of the potentials between all agglomerations in an area.

$$V = \sum A \cdot \frac{P_A \cdot P_B}{\epsilon^{1.7}} \tag{1}$$

where  $P_A$  and  $P_B$  is the population of two agglomerations,  $\epsilon$  is the distance between them and  $A$  is a factor for the affinity for high-speed railway traffic (travel speed of 200 km/h) with the following form:

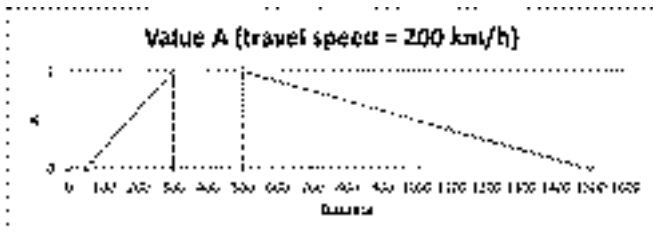
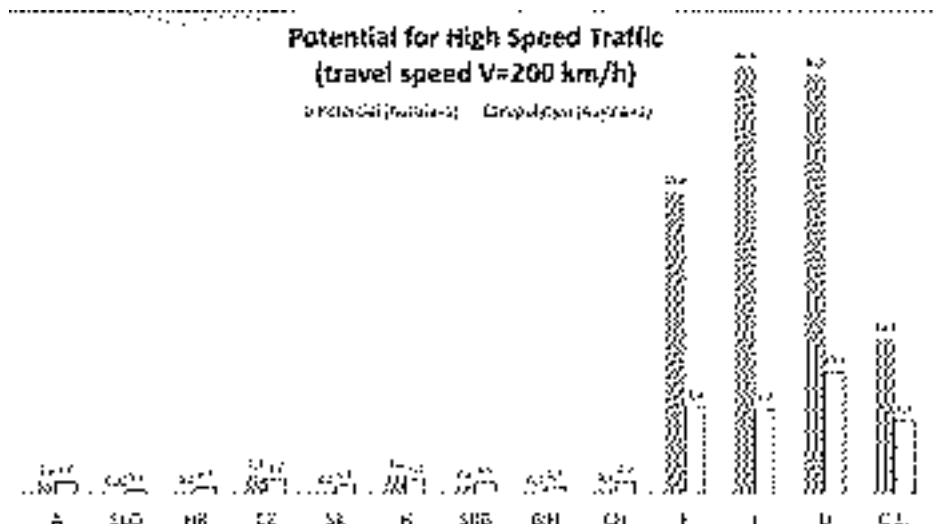

Figure 2 Value A [1]

With this formula, we can estimate the potential of high speed-traffic in Central Europe, comparing it to Switzerland, Germany, Italy and France. It shows that the countries in the project area all feature very low potential for high-speed traffic. If plotted next to the population of the countries (both normed to Austria's values for comparison reasons), one could identify that the potential rises exponentially with the population. However, even if we consider all Central European countries combined, resulting in an approximate population of Italy or France, the project area still bears significantly lower potential for high-speed traffic. This is due to the aforementioned structural characteristics shared by these countries.



**Figure 3** Potential for High Speed Railways in Europe. 'C.E.' denotes all countries of the Central European project area together

Therefore, we can regard high-speed traffic as inadequate for Central Europe. The integrated timetable, as operated in Switzerland with great success, is the ideal form of railway operation, making best use of the potential.

## 6 Current status of integrated periodic timetables in Europe

To get an overview whether the adequacy of integrated timetables for Central Europe also reflects the individual countries' timetable goals, the current state of Integrated Timetables in Europe was examined:

- The Czech Republic has already introduced an ITF scheme on most relations, including a long-term aspiration for ITF-compatible infrastructure upgrades.
- In Slovakia, the main lines operate in regular intervals, but without an integrated approach.
- Austria introduced its first ITF in 1991. Infrastructure improvements were loosely linked to the timetable requirements, yet led to sensible travel time improvements. In 2011, a long-term systematic concept that linked infrastructure and ITF was published and is followed since.
- Hungary, like the Czech Republic, already features an ITF on a great portion of the network. A long-term objective for integrated infrastructure and timetable development exists.
- Slovenia, Croatia, Serbia and Bosnia-Herzegovina do not feature an Integrated Periodic Timetable at present.

From this status, the conclusion is that Central Europe, generally speaking, is progressing the right way towards a pan-European Integrated Timetable.

## 7 Integration of national timetables

The widespread occurrence of ITF across Central Europe prompts the question whether the timetables of the individual countries clash along the borders. Three main factors are responsible for compatible international timetables.

### 7.1 Selection of the same cities as hubs

For historical reasons, several of the studied countries feature important railway stations close to the border, resulting from former border checks and system boundaries. Due to their operational importance, many of them have been selected as ITF hubs. On the other side of the border, however, we very often find the same situation, with a low ride time between these hubs. For serving both hubs, this travel time has to be stretched artificially to multiples of 30 minutes.

The only solution here is a multilateral agreement on which of the two stations should serve as hub and which one serves simply as an ordinary intermediate stop. Given the fact that a lot of border stations do not feature a potential to justify a stop of long-distance trains, a very convenient solution is to abandon both stations as hubs, thus spreading necessary infrastructure improvements among the involved countries and in doing so minimising construction costs.

### 7.2 Considering loops instead of lines

As mentioned in [4], ITF networks should be considered as multiple interlinked loops. Thus, international connections do not only form a line, but part of two elementary loops. If the two neighbouring ITF would request an unattainable ride time between hubs, a separation line extending across the whole network can ease infrastructure demand on several lines simultaneously, adding the same amount of ride time to all affected lines. If the line is cautiously drawn along problematic lines, construction costs can be significantly reduced.



Figure 4 Separation lines within the network [2]

### 7.3 Softening of strict ITF rules

The basic principle of the ITF implies very strict rules and can result in unattainable infrastructure requirements [2]. However, these rules are based upon the idea of an identical interval across the whole network. As many lines in the project area already operate at a 30-minute headway, loops touching these lines have double the possibilities of ride time reduction. Also, very often there is more than one long-distance product, resulting in two different travel times along one line, which allows more possibilities and reduced construction costs.

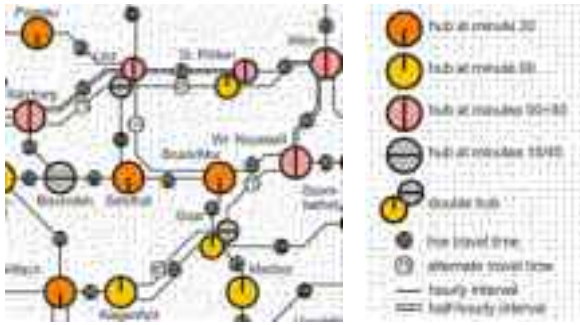

Figure 5 30-minute headways and products with different ride times.

## 7.4 Timeline for network integration

It is obvious that current infrastructure often does not allow sophisticated travel time reductions. It is also obvious that any international coordination, even if based upon the current network, will significantly improve the offer in railway traffic, mostly though optimised changes at hubs.

Therefore, the international coordination in terms of network integration needs to start immediately, to rapidly approach the first steps of an improved offer.

Furthermore, the future networks of the individual countries need to be coordinated. Any investment resulting from a concentration on just the national networks could potentially result in sunk costs. Therefore, coordination for future networks also needs to start right now.

## 8 Conclusion

It has been deftly demonstrated that the Integrated Periodic Timetable is the most appropriate solution for Central European railways. As many countries are developing ITF schemes and as greater numbers of infrastructure projects are based upon the requirements imposed by the ITF, the development within Central Europe is progressing successfully. However, efforts for international cooperation for integrating national ITF concepts need to be made in order to optimise the international integration of the respective railway networks.

The best point in time for starting these coordinations is now, as

- Infrastructure demands highly depend upon the ITF and
- Upgrade of Infrastructure is planned for the coming years.

Only in taking ITF principles into account in planning the upgrade of the infrastructure, sunk costs can be avoided and the benefits, nationally and internationally, of the investments can be maximised.

## References

- [1] Mairhofer, G.: Hochleistungsbahnen: ein Überblick über wesentliche Aspekte ausländischer und österreichischer Hochleistungsbahnen. Diploma Thesis, Graz University of Technology, 1991.
- [2] Utenthaler, H.: Grundlagen eines auf einem Integrierten Taktfahrplan basierenden Eisenbahninfrastrukturausbaues am Beispiel Zentraleuropa. Diploma Thesis, Graz University of Technology, 2010.
- [3] Borza, V., István, Gy., Kormányos, L., Vincze Béla, Gy.: Integrált ütemes menetrend I. [http://itf.hu/index.php?option=com\\_content&view=article&id=49:integralt-uetemes-menetrend-I](http://itf.hu/index.php?option=com_content&view=article&id=49:integralt-uetemes-menetrend-I), 29.02.2012
- [4] Lichtenegger, M.: Der Taktfahrplan. Abbildung und Konstruktion mit Hilfe der Graphentheorie. Minimierung der Realisierungskosten. Dissertation, Graz University of Technology, 1991.



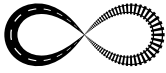

## THE DEVELOPMENT OF THE INTEGRATED PERIODIC TIMETABLE IN AUSTRIA

Helmut Uttenthaler

*ÖBB Personenverkehr AG (Austrian Federal Railways, passenger traffic division), Austria*

### Abstract

More and more, European railways are introducing the Integrated Periodic Timetables (ITF). The idea of the ITF is simple: Trains from different directions meet at hub stations at the same time in regular intervals. Thus optimal connections with short waiting times can be provided. In Austria the first nationwide ITF, the 'NAT91', was implemented in 1991. Only a few ideal ITF-hubs were possible then, because this timetable was introduced without any prior infrastructure improvements. But short- and long-term plans to upgrade the infrastructure were already made at that time. Unfortunately the short term improvements were not carried out, so the NAT91 couldn't be developed further. It was drastically reduced in 1996 and then the ITF-philosophy lost popularity amongst railway managers and politicians.

The new long-term strategy for the Austrian railway infrastructure (the 'Zielnetz 2025+') now again contains a long term ITF goal. The fact, that the first designs for many major infrastructure projects of the 'Zielnetz 2025+' were made already back in the early/mid 1990ies, now helps to plan the future ITF: the upgraded Westbahn between Wien and Wels as well as the new Koralm-line between Graz and Klagenfurt were always designed to fit into an ITF-hub system.

*Keywords: timetable; railway; infrastructure*

### 1 Introduction

The Integrated Periodic Timetable (ITF) is based on hubs, where train from various directions meet at the same time. Thus the waiting time for connections in all directions can be shortened, which helps to reduce travel times in the whole network – and not only for certain point-to-point trips.

Therefore, the ITF is the ideal timetable system for countries like Austria, where the population is not concentrated on few very big agglomerations. More than 50% of the population lives in municipalities of less than 7500 inhabitants.

A perfect ITF cannot be implemented from one day to another. To make ITF hubs possible at the needed places (where several railway lines meet), it is necessary to enable travel times of less than 30, 60, 90, etc. minutes between them. Often this is only possible with major infrastructure upgrades, which require a lot of time and money.

In Austria, the first plans to create an optimized ITF similar to the Bahn200-system were created in the late 1980ies. Unfortunately the consistency to follow these plans was not always as distinctive as in Switzerland. Today the plans for an optimized ITF are more serious than ever before, but it will take some years more until the planned system can be implemented.



## 2 The history of ITF in Austria

### 2.1 The first steps: Austrotakt 1982

In Austria the first periodic timetables were introduced in 1978 between Vienna and Salzburg and between Vienna and Graz. In 1982 the periodic timetable was extended to Innsbruck and Villach. The system was called 'Austrotakt' and consisted of four lines, which ran every two hours:

- Vienna – Salzburg – Innsbruck (via Kufstein)
- Vienna – Salzburg (some trains continued beyond Salzburg to Innsbruck via Zell am See)
- Vienna – Bruck/Mur – Graz
- Vienna – Bruck/Mur – Villach

Thus from Vienna to Salzburg and Bruck/Mur an hourly service was provided. Bruck/Mur can be called the first ITF hub at the full hour which enabled connections from Graz to Villach between the lines Vienna – Graz and Vienna – Villach.

However, all other intercity trains and most local trains (except the S–Bahn system of Vienna) kept their traditional timetable with irregular departure times and without coordinated connections. So the benefit was limited to the areas served by the lines mentioned above.

Ideas about a nationwide ITF already existed since the late 1970ies, but they were made by private railway enthusiasts, whereas at that time the planning departments of ÖBB considered a network-wide ITF as an idea of just theoretical relevance.

### 2.2 From the NAT91 to the NAT2000

Only in the late 1980ies the management of ÖBB changed its attitude towards the network-wide ITF. The Swiss experience with the development of the ITF, the results of a survey by Arthur D. Little about the future development of Austrian Railways and the continuing commitment of private railway proponents finally led to the planning of the NAT91 (Neuer Austrotakt 1991), which was implemented in 1991.

With this timetable regular intervals, better connections and more trains were introduced on wide parts of the network. The NAT91 followed ITF-principles, but it was implemented without prior major infrastructure upgrades, so real ITF-hubs at the full or half hour could be created only at some places (like Innsbruck, Salzburg or Wiener Neustadt).

But the idea of a network-wide system of ITF hubs similar to Bahn2000 in Switzerland was the base for the upcoming modernization plans for the Austrian railways at that time. There were step-by-step plans to improve the NAT91 until the year 2000. Figure 1 shows the planned hub system of the 'NAT 2000' after completion of the infrastructure upgrades [1].



Figure 1 ITF hub system of the planned 'NAT2000' [1].

### 2.3 Ten lost years?

Although the passenger traffic flow increased by 12% within two years (1990 – 1992), the decision-makers considered the operating costs for the additional train services too high and first cut-backs were made already in 1992.

The planned integration of bus-services didn't happen and also some minor infrastructure upgrades, which would have been needed for the first steps towards the NAT2000, were postponed. This didn't help and finally led to the decision to basically abolish the NAT91 in 1996. The new timetable (called 'Optimierter Personenverkehr (OPV) 96') still followed ITF-principles, but the number of train services was severely reduced. Within two years the passenger flow fell by 18% – all the gains made by the NAT91 were lost [3].

Under these circumstances any thoughts about an offensive timetable strategy as the base for the long term development of ÖBB were practically dead. The focus was laid on the development of freight business.

However, the plans to improve the infrastructure continued, but without a clear long-term network-wide goal for an ITF. Fortunately the ideas and plans for many projects were already created in the early 1990ies – when ITF-compatible travel times were considered a main goal for the infrastructure improvements.

This applies to the upgrading of the Westbahn between Vienna and Wels. Also the first concrete plans for the new Koralm-line between Graz and Klagenfurt, which were not yet mentioned in the NAT2000-plans, were based on a travel time of slightly less than 60 minutes between Graz and Klagenfurt.

### 2.4 Plan912

The foreseeable completion dates of major infrastructure projects like the new line Vienna – St. Pölten or the new Vienna main station lead to the start of the project 'Plan912' in 2005. It was recognized that a strategic timetable goal was necessary to maximize the use of these infrastructure projects. The title refers to the originally planned main introduction phases in 2009 and 2012. However, some assumptions about the progress of infrastructure projects were too optimistic in the beginning, so some parts of Plan912 are delayed and will be implemented in the next few years.

The Plan912-system already contains full ITF-hubs at St. Pölten, Linz, Attnang-Puchheim and Salzburg on the Westbahn as well as at Wiener Neustadt and Bruck/Mur on the Südbahn. The hubs on the Westbahn were enabled by 200 km/h-operation (instead of 160 km/h) of Intercity-trains, which was introduced in 2008. Hubs are also planned in Vienna (new main station) and in Amstetten (where now some minutes are still missing). From 2015 the hub at Vienna will greatly improve the connections between the different lines radiating from Vienna and shorten travel times e.g. from Bratislava to Linz or from St. Pölten to Graz. Transfer stations will be the new main station and the station Vienna Meidling.

Among other Plan912 improvements were additional trains to the south (Vienna – Graz hourly), between Vienna and Munich (new direct railjet service Budapest – Munich every 3 hours) and between Salzburg and Innsbruck (one train per hour instead of one every two hours). The routes Vienna – Innsbruck – Zürich and Vienna – Villach were accelerated by reducing intermediate stops. Also projects to improve suburban services around provincial capitals (S-Bahn Tirol, S-Bahn Graz, etc.) have been carried out within the Plan912 project. The improved train services already had an impact on the passenger flow: after a long period of stagnation since 1997 it increased by 23% within the period from 2004 to 2010. [3]

### 3 New perspectives for the future

#### 3.1 Zielnetz 2025+

In 2007 ÖBB and the transportation ministry decided to create the 'Zielnetz 2025+' ('target network 2025+') – a long-term strategy for the development of the Austrian railway infrastructure until 2025 and beyond, which should enable a better coordination of infrastructure investments and should also be compatible with goals of the Austrian traffic policy. The 'Zielnetz 2025+' was published in september 2011 and for the first time after more than 15 years an ITF hub system again found its way into the official infrastructure strategy. [2]



Figure 2 ITF hub system of the 'Zielnetz 2025+'

Some thoughts of earlier concepts like the 'NAT2000' or 'Plan912' can be found also in the Zielnetz 2025+, especially concerning parts of the Westbahn–axis between Vienna and Attnang–Puchheim.

West of Attnang–Puchheim an earlier planned new alignment of the Westbahn is now postponed to a later date beyond the Zielnetz 2025+, but a 15/45–hub in Salzburg can be enabled with a short new line east of Salzburg (Neumarkt–Köstendorf–Salzburg).

Towards the south by the year 2025 the Semmering–tunnel and the Koralm–line form a new attractive axis with ITF–compatible travel times.

Whereas earlier concepts focused on domestic services, the Zielnetz 2025+ also takes international connections into account. ITF–compatible travel times to nearby hubs in Breclav, Bratislava or Győr are the base for international coordination of the national ITF–systems. They also helped to decide the necessary design speed for lines, which will be upgraded in the future: for example, the question of 160 vs. 200 km/h on the Nordbahn from Vienna to Breclav could only be answered with the knowledge of the necessary travel time. 160 km/h proved to be fast enough, so a lot of money could be saved.

The system now also included two different categories of express services on the main–axis between Vienna and Salzburg and between Vienna and Villach. Accelerated services don't need to serve all intermediate hubs, but are connected to the basic system on both ends of the accelerated section. The accelerated trains are those who are designed to continue beyond Villach and Salzburg to places like Venice and Innsbruck/Zurich. Thus the principles of the ITF can be combined with the requirement for accelerated services to reduce travel times on longer routes (like Vienna – Innsbruck).

#### 3.2 Timetable 2025

Currently the main focus is laid on the design of an exact system timetable for the year 2025. As not all projects of the Zielnetz 2025+ will be finished in 2025 due to financial restrictions (hence the 'plus' in the title 'Zielnetz 2025+'), the hub-system of the Zielnetz 2025+ had to be modified a little bit around Salzburg and in the west of Austria.



Figure 3 Planned ITF hub system for 2025 – based on the Zielnetz 2025+

Salzburg will continue to be a hub at the full hour. On the Westbahn between Vienna and Salzburg the ITF is based on the Plang12-strategy. The Tauern-line from Salzburg down to Villach (travel time slightly less than 2½ hrs) defines the further hubs on the new 'Südbahn' between Villach and Vienna via Graz. Travel times of 1¾ hrs from Vienna to Graz and 2½ hours to Klagenfurt will be faster than going by car and are also the basis for better international services from Vienna to Italy, Slovenia and Croatia.

The cross-country links through the Alps will be provided through a new system of 'Interregio'-trains. The upgrade of the Pyhrnbahn (between Selzthal and Linz) also gives a new perspective to the Graz-Linz line with a travel time of just 2½ hours (eventually not yet possible in 2025, but at a later time) and optimized connections to Nuremberg via Passau. The future ITF will enable significant travel time reductions for many city-pairs. Table 1 shows the travel time reductions between provincial capitals. It can be seen that especially the new Südbahn (Semmering tunnel and Koralm-line) and the improved connections via Vienna greatly reduce travel times – Graz, Klagenfurt and Eisenstadt will see the most significant reductions.

Table 1 Travel time reductions 2012/2025 between provincial capitals

Travel time reduction 2012/2025 (h:min)									
	Wien Hbf	Eisenstadt	St. Pölten	Linz	Salzburg	Innsbruck	Bregenz	Graz	Klagenfurt
Wien Hbf									
Eisenstadt	-00:20								
St. Pölten	-00:10	-01:10							
Linz	-00:20	-01:20	-00:10						
Salzburg	-00:20	-01:20	-00:10	-00:05					
Innsbruck	-00:25	-01:25	-00:15	-00:05	-00:05				
Bregenz	-00:30	-01:30	-00:20	-00:10	-00:10	-00:00			
Graz	-00:30	-00:30	-00:15	-01:00	-00:20	-00:05	-01:00		
Klagenfurt	-01:25	-01:40	-00:15	-00:10	-00:15	-00:25	-00:40	-00:10	

The ITF-hubs of the 2025 timetable, which will be implemented in the whole öBB network, will be the base for optimized connections also to local and suburban services. Thus travel time reductions will not only occur on main lines, but will be noticeable in wide parts of Austria. Figure 4 shows the principle of an optimized ITF-hub in Amstetten, where changing between all kind of trains will be possible within a few minutes.



Figure 4 Example of the future ITF-hub Amstetten based on half-hourly services.

## 4 Conclusion

The ITF in Austria already has a long history with some ups and downs. It finally seems that in the next few years it will become reality. The fact that many major infrastructure projects were designed according to ITF requirements helps to create a network-wide ITF system until 2025, even if sometimes the initial ideas were temporary forgotten.

The Austrian example shows that the first concepts of major infrastructure projects determine the future possibilities. It is therefore very important to consider ITF principles from the beginning.

The fact that the perfect Austrian ITF will hopefully be realized by 2025 and thus be delayed by 20 years compared to Bahn2000 in Switzerland also shows the need for pursuing a goal consequently – which did not always happen in Austria.

## References

- [1] Temming R.: Eisenbahn für morgen schon heute, Kaiser Verlag München, 1990
- [2] ÖBB Infrastruktur AG: Zielnetz 2025+ (final report), 2011
- [3] UIC railway statistics, <http://www.uic.org/spip.php?rubrique1449>, 25.03.2012



## DEVELOPMENT OF PERIODIC TIMETABLE IN THE CZECH REPUBLIC

Vít Janoš, Karel Baudyš

ČVUT v Praze, Fakulta dopravní, Česká Republika

### Abstract

This paper is focused on Timetable scheduling in railway transport in the Czech Republic. It brings comparison of commercial and periodic timetable, which is used in Czech Republic mostly for long–distance railway lines since 2003. In the Czech Republic an integrated periodic timetable (IPT) scheme was implemented in long–distance railway passenger transport, which is ordered by the Czech Ministry of Transport. A demand driven timetable structure was long typical for the Czech Republic. Trains were operated at times of supposed demand. Thus the 2004/05 timetable brought a huge amount of change, primarily in national long–distance lines now operated in a standardised manner. The network was gradually brought in line with a unified national scheme based on IPT–type oo–symmetry and IPT hubs were created. The way from 'demand' timetable to regular timetable scheme based on the 'Swiss Model of Integrativer Taktfahrplan' was in the Czech Republic not easy, and today, the whole system is still continuously developing. In terms of passenger numbers in publicly ordered long–distance traffic the success of the new timetable concept became apparent after two years: Increase in passenger numbers ranged from 10 to 40 per cent for the railway lines realigned according to the IPT scheme, and after four years it amounted to 20–120 per cent as compared with the base year. The enhanced system has offered more train kilometres and connections. Principle of Integrated Periodic Timetable is very easy, but to have efficient supply of train services is necessary to fulfil some requirements for whole transport system. The advantages, problems by implementing and also the result of implementing of this new supply in public transport system in Czech Republic are describe in this article.

*Keywords: timetable, railway transport, periodic timetable, long distance traffic*

### 1 Introduction

Timetable is a basic instrument for organizing railway transport. Though, it represents supply of connections in network for passengers. Generally, timetables can be divided into fixed (periodic) and commercial (non–periodic).

Commercial timetable is characterized by conducting trains in different intervals. Train departure and arrival times can better come up to exact passengers' demands for arrival/departure to/from particular trip source/target. In practice it is mostly long–term stable supply, which does not change for several years. Passengers use it rather because of persistence and partially bring their demands into line with it.

However, in lands with developing economy passenger demands are changing from particular times to temporal and spatial availability. Public transport, which should compete with individual transport, should offer frequent, fast connection, between all spots in network. Such supply can be created thanks to fixed (periodic) timetables. Temporal availability is guaranteed by appropriate period between trains. Spatial availability is guaranteed by suitable

ble coordination of train time positions (time slots) on tracks and in junctions. Every regular timetable has a symmetry axis. Trains run symmetrically in both ways around that axis and in case of an XX:00 axis they meet in hubs around the full hour. Based on Integrated Periodic Timetable (IPT), lines in particular area are interconnected so that there are realised optimal changing connections, i.e. without waiting times.

## 2 Present timetable planning in the Czech Republic

Majority of Czech trains are operated by Czech Railways. Some regional trains are operated by private transport companies.

Fast trains, EuroCity (EC), InterCity (IC), Expres (Ex) and Rychlík (R) trains (long-distance trains) are ordered as public transport service from Czech Ministry of Transport. This, as an orderer, decides about their timetable.

Regional trains are ordered as public transport service by regional authorities, who establish their timetable. Of course, their timetable has to be coordinated with timetable of long-distance trains. Regional authorities also discuss this problem with Ministry of Transport and transport companies, too.

There are some long-distance trains, which are not ordered by anyone, as they are operated on own entrepreneurial risk of Czech Railways or of private rail companies. These trains (category SuperCity – sc of Czech Railways, RegioJet of StudentAgency or LEO Express of Aakon Capital Group – in operation from 12/2012) operate between capital city Prague and greatest Moravian agglomeration of Ostrava, parallel to long-distance train lines ordered by Ministry of Transport.

## 3 Timetable development in the Czech Republic between 1983–2003

A demand driven timetable structure was long typical for the Czech Republic (former part of Czechoslovakia). Trains were operated at times of supposed demand. The 1983/84 timetable featured a first attempt at regularity: Regional passenger trains ('Os'-type trains) of the Praha–Kolín line ran at a 60/30 minutes interval with minor diversions (trains pulled by an engine are slower than electric multiple units). For years this timetable was continued there without modifying or extending it.

The 1993/94 timetable saw a degree of regularity for International trains. The traditional Vin-dobona and Hungaria express trains of the 'Eurotakt' line linking Hamburg and Berlin with Vienna and Budapest via Prague ran to a regular timetable by then. Thanks to that, symmetry by the '00 minute' first appeared in Czech timetable in 1994/95.

Beginning with the 1995/96 timetable regular interval timetable was extended to Prague suburban lines, for regional passenger (Os) trains of the Praha–Kralupy and Praha–Beneš-šov lines. One year later Os-trains of the Praha–Beroun line were included, and from the 1997/98 timetable, with Praha–Nymburk–Kolín the last double track line of the Prague suburban system was included. These local lines were island operations, not forming a consistent network with through-links via Prague combining two lines, interval length varied during the daytime and each line used a different symmetry axis.

The 2000/2001 timetable brought two major changes to the Czech Republic. First, the 'Eurotakt' trains were diverted to the Praha–Česká Třebová–Brno corridor line almost completely reconstructed and 20 minutes faster. Second, the 'Egronet' project was launched, reorganising regional cross-border traffic including the Zwickau/Plauen–Cheb–Marktredwitz and Zwickau–Kraslice–Sokolov Railway lines, it is operated partly by state railways, partly by private company Viamont (Kraslice–Sokolov). Egronet traffic is part of a full-fledged regular interval traffic with 00-symmetry and good connections in Bavaria as well as in Saxonia.

The Egronet network provided a good pattern and a stimulus for the reshaping of national regional transport. Two pilot projects were initiated to that end in the 2002/03 timetable

incorporating oo-symmetry, the first in the North-western Bohemian Region featuring the Roudnice–Ústí nad Labem–Děčín and Ústí nad Labem–Chomutov–Karlovy Vary–Cheb lines, the other one in the Ostrava area with the Ostrava–Opava, Přerov–Ostrava–Český Těšín–Mosty u Jablunkova, Ostrava–Havířov–Český Těšín and Ostrava–Frenštát pod Radhoštěm lines. Next to these regional projects, that year regular interval became dominant in national long-distance travel. The 2002/03 timetable season marks a break, it was the last year when the decision on timetable structures was the sole responsibility of state railways ČD.

#### 4 Development of Periodic-Timetable-Network in the Czech Republic from 2003

The Ministry of Transport started to order long-distance traffic (Ex and R-type fast trains) from the 2003/04 timetable year. Also a regional structure of ownership by the 14 Bohemian and Moravian regions was created, extending to Sp and Os-type regional trains. Thus the 2004/05 timetable brought a huge amount of change, primarily in national long-distance lines now operated in a standardised manner. The network was gradually brought in line with a unified national scheme based on IPT-type oo-symmetry and IPT hubs were created. This first giant system leap was quite fiercely opposed within the railway organisation, the most prominent argument being that trains should continue to operate when most people need them rather than according to an 'unknown system' leading to many 'useless' connections next to a lack of capacity for freight transport. It took about five years for the entire organisation to embrace the idea of a comprehensive national IPT.



Figure 1 IPT-type junctions Plzeň (2006) and Olomouc (2009) in the Czech long-distance rail network

The regular interval concept not only created many new links and train services, it also terminated traditional direct links that did not fit the new scheme such as the Praha–Jeseník or Most–České Budějovice direct express train services. Sections that lost their long-distance trains were branched into the national long-distance network. Such changes partly explain opposition within the railway organisation. It was therefore avoided to advance too fast. The new concept was progressively introduced within a five-year period as follows:

- 2003/04 – drafting the new concept, first adaptations;
- 2004/05 – first big system change including an additional seven per cent of train kilometres;
- 2005/06 – further system adaptation without additional train kilometres;
- 2006/07 – further adaptation including an additional five per cent of train kilometres;
- 2007/08 – further adaptation including an additional 15 per cent of train kilometres; the Ministry of Transport from now orders the timetable of EuroCity and InterCity-type trains, EC supplements are abolished. ec and ic trains form the upper service level within the national timetable, therefore a unique tariff scheme for the entire system is established;
- 2008/09 – intervals made shorter on main lines, an additional twelve per cent of train kilometres;
- from 2009/10 onwards – stabilising and realigning the scheme.



In terms of passenger numbers in publicly ordered long-distance traffic the success of the new concept became apparent after two years: Increase in passenger numbers ranged from 10 to 40 per cent for the railway lines realigned according to the IPT scheme, and after four years it amounted to 20 to 120 per cent as compared with the base year. The most distinguished results were reported from the Praha–Ústí nad Labem line where a two-segment order of services with a consistent regular interval was established. The number of trains on this corridor line was almost doubled, instead of the initial two long-distance lines there are three lines representing a different policy of train stops serving almost six times as many passengers than four years ago – thousands of passengers daily who did not travel by rail before.

The role of the Ministry of Transport is limited to ordering long-distance public transport. Without such an order (without compensation payments) State Railways only operate their SuperCity (sc) type 'Pendolino' tilting trains between Prague and Ostrava. As regional transport now belongs to the regions, negotiations are necessary between the Ministry and the various regions. There is no such a thing in Czech Republic as an 'obligation of linkage' between regional and national systems, every owner is free to set their priorities. This explains why we can find within the Czech system many instances of excellent connections between regional and long-distance lines next to linkups that do not work well or do not exist at all.

Regional owners in favour of IPT-type timetables who have implemented a good set of linkups with long-distance lines are the Praha, Brno, Plzeň, Ústí nad Labem and Hradec Králové regions, and the situation is not bad in the Ostrava, Olomouc, Zlín and Liberec areas. To date no national transport planning scheme for regional transport has set the pace for development of the entire system. Each owner is responsible for their planning, including coordination with neighbouring regions and with the Ministry. Most regions have installed a transport and conceptual work coordinator. The Ministry for its part has established close relationships with Institut für Regional- und Fernverkehrsplanung (IRFP – Institute for Regional and Long-distance Transport Planning) in Dresden and České vysoké učení technické (ČVUT – Czech Technical University) in Praha.

Next to the problem of the reluctance of the entire railway organisation to adopt an 'IPT mindset', another set of problems is related to quality issues. The railway company uses old rolling stock for most long-distance services the daily circulation of which has been optimised through IPT. The comfort offered by current stock does not match twenty-first century expectations and the intense use of old stock puts additional strain upon them which can be detrimental to reliability and punctuality. Construction due to the developments of corridor lines also affects timeliness.

The regular interval timetable scheme has brought many new passengers to railways. If we want them to remain we cannot allow the pace of change to slow down. Following the first two essential steps of introducing regular timetable and integration of public transport modes, the biggest potential is with the development of rolling stock. Also more time and effort must be dedicated to annual timetable planning, including the simulation of bottlenecks and the creation of intervention scenarios for cases of disturbances or unforeseen events.

The present Czech regular interval timetable scheme cannot yet be regarded as final. Much remains to be achieved such as diminishing intervals on busy relations, introducing accelerated services on modernised lines and creating new hubs through infrastructure investments. The aim is to create an efficient system demonstrating to passengers that railways can be the backbone of an attractive, flexible alternative to private transport.

## 5 Current risks of further development

The further development and improvement of IPT in the Czech Republic will be only possible with IPT-harmonized infrastructure improvements. However, the crucial condition represents the ordering of long-distance trains based on the principle of controlled competition or franchises (exclusive rights) without applying of full open-access. The nowadays step by step implemented open access in long-distance transport associated with reducing of compensation leads now to reducing of ordered long-distance train performance unfortunately. This reduced compensation results in 6,5 per cent decreasing performance given in long-distance train kilometres for timetable year 2012.

### References

- [1] Janoš V., Baudyš K.: Railway Timetable in Czech Republic. In The Development of Transportation Systems. Gliwice: Wydawnictwo Politechniki Slaskiej, 2010, p. 181-186. ISBN 978-83-7335-672-6
- [2] Hesse W., Baudyš K., Janoš V., Pospíšil J., Guckert M.: Landesweiter Integraler Taktfahrplan für Tschechien - eine Studie. Eisenbahn-Revue International. 2010, Jahr. 2010, nr. 11, S. 596-599. ISSN 1421-2811
- [3] Janoš V., Baudyš K., Michl Z., Pospíšil J.: TIMETABLE ENGINEERING IN RAILWAY TRANSPORT IN CZECH REPUBLIC. In Trans & Motauto 2010 [CD-ROM]. Sofija: Scientific-technical union of mechanical engineering, 2010, ISSN 1313-0226
- [4] Janoš V., Baudyš K.: Expansion limits of personal railway traffic in Czech Republic. In 17. medzinárodné sympóziium 'Zvyšovanie konkurencieschopnosti európskeho železničného systému' EURO - Žel 2009. Zborník prednášok. Žilina: Technical University of Žilina, 2009, díl 2, s. 215-221. ISBN 978-80-554-0024-2.
- [5] Neumann I., Janoš V., Borza V.: Eastern European Railways in Transition 19th to 21th Century; current in print



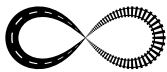

## IMPLEMENTATION OF PERIODIC TIMETABLE IN REGIONAL PASSENGER TRANSPORT OF REPUBLIC OF CROATIA

Tomislav Josip Mlinarić<sup>1</sup>, Tihomir Pleša<sup>1</sup>, Inda Balagić<sup>2</sup>

*1 Faculty of Transport and Traffic Sciences, Zagreb, Croatia*

*2 Graz Technical University, Graz, Austria*

### Abstract

Periodic timetable is designed as a new, more accessible and efficient system for organization of passenger rail transport that does not require a large investment interventions. It offers possibility for much needed regularity in Croatian public railway transport supply. Considering the current condition of Croatian railway system and its environment this approach appears to be the most efficient. Primary features of periodic timetable are its readability for the final user and symmetry as it thus seems more attractive and efficient. The principle of periodic time table itself ensures systematization of operations in stations and therefore provides improvements to the safety standards. With its transparency this type of timetable also greatly contributes to the quality of services and thereby increases the chance among competitors in a growing market of railway operators.

The paper refers to the identification of technical and technological parameters of the track infrastructure as a function of periodic timetable for the regional passenger transport system of Croatian Railways. The outcome of the research aims to possibilities of gaining productivity through more rational use of resources, namely rolling stock, but also through cohesion of the network. The further benefits will be setting grounds for implementing timed connections to other modes of urban transport, thus, integrating time tables [3]. This will propose the much higher level of service which will have the railway passenger transport in its core structure.

*Keywords: regional passenger transport; periodic timetable, integrated timetable*

### 1 Introduction

Transportation of people and goods between regions has never been more challenging task. There are so many demands to meet in attempt to stay in competition. Some important issues are speed, time accuracy, accessibility and affordability. All these parameters must be taken into account when constructing regional passenger transport.

Road transport in Croatia, although overloaded, seems to have more effective answers. In 2007 the same number of passengers was transported by rail and road [6]. This number increased in 2010 and the difference went in favour of railway by some 19%, but that is still not enough from the ecological point of view, not to mention road traffic congestions.

This paper proposes some solutions for so much needed rapid railway transport between major regions in Croatia. Introducing Periodic Timetable, or originally Taktfahrplan, can offer regularity and cohesion of the service that will attract passengers even from competition. This kind of service must offer speed that will compete with other modes, but stay affordable at the same time. Another aspect is comfortability which is not a priority but it can attract certain percentage of more demanding passengers. Here will come in handy new diesel and electric motor units that HŽ will invest in. These investments are based on prognosis that in

the period from 2010 to 2015 the rate of increase in passenger number just in regional transport will be 3.5% [4].

There is more often another term in use when it comes to marketing: 'user friendly'. In timetable planning it means recognisable service, looking simple and easy to remember. Also, all services of a kind must be identical to each other.

It is proposed to implement periodic timetable in central part of HŽ network as a first step in the research of implementing integrated periodic timetable on a much wider scale.

## 2 Periodic timetable

### 2.1 The history

'Integraler Taktfahrplan' or 'Integrated Fixed-Interval Timetable' was introduced for the first time on Dutch Railways, the Rotterdam–Schevening line. After successful introduction the Dutch started implementation of the Periodic Timetable throughout the whole network in 1932. Similar idea was implemented afterwards on distant service lines of the British Railways.

The real value of the Integrated Periodic Timetable was recognized in the 1970's by the two Swiss engineers Samuel Staehli and Hans Meiner. In that period Swiss Railways were facing a real threat – expansion of highways throughout the Switzerland what could mean losing a big portion of the market. After several failed projects, taking into account all prior deficiencies, they managed to construct an integrated timetable for the whole network, connecting all major and some smaller cities. The plan was presented in 1982 and in 1987 was adopted at national level as 'Project Rail 2000'. Basic feature of the new model was emphasizing the importance of the actual timetable [1]. The main characteristic of the Periodic Timetable is that all trains arrive at stations (nodes) approximately at the same time and at the same time depart in different directions. Integrated Periodic Timetable is an innovative public transport system that ensures periodic, better connected and reliable service. The implementation on Swiss Railways was carried out in stages on individual sections which were afterwards interconnected. First results showed a 20% increase in the number of trains and only a 4% increase in costs which has resulted in long-term success in rail passenger transport (Figure 1). This success encouraged and inspired other rail operators, and this type of service spread throughout Europe. The system was successfully implemented in Germany (Bayern-Takt), Austria (Austrotakt NAT, Plan912), France, Hungary, etc.

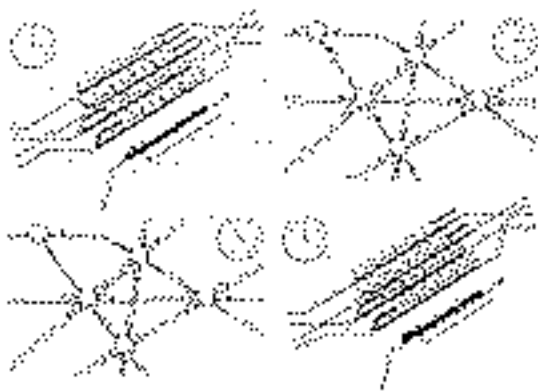

Figure 1 Knotensystem Bahn 2000 – 2 hour 'takt' [1]

## 2.2 Advantages

Basic features of an Integrated Periodic Timetable are its periodicity, symmetry and 'everywhere to everywhere' connections in nodes which maximize the coherence of the region. These basic features make this timetable memorable and accessible to end users and therefore market oriented. It makes changing connecting trains quite easy and waiting times are minimal. From the technical aspect, the construction of the Periodic Timetable is being done on 24 hour basis and as such is applicable on the whole week (except modifications for the weekend and holidays). Benefits for the passengers are reduced travelling time, drastically reduced waiting times and increased traffic density. The whole timetable is more transparent and increases mobility.

## 2.3 Disadvantages

The Periodic Timetable system does not tolerate any interference. In case of delay the defect ripples through the network and resuming normal operational condition requires great efforts. All likely possible delays must be taken into account so that all possible damage can be kept to a minimum. This is considered the main disadvantage of this kind of service. Another possible problem for the network is the fact that a large number of trains must be simultaneously present at the station which could point to lack of infrastructure and result in forming of bottlenecks.

# 3 Technical and technological parameters

## 3.1 Regional network setup

For implementing periodic time table dedicated specifically to regional passenger transport, some guidelines need to be set. Taken into account the Croatian topography and present train running times, it is proposed that technological delimitation between urban/suburban and regional transport is being set on a base of amount of travelling time. Accordingly, approximate travelling time for the urban/suburban services is proposed to be 60 minutes to or from given regional centre. Such determined areas are shown in Figure 2 for the towns of Zagreb and Varaždin.

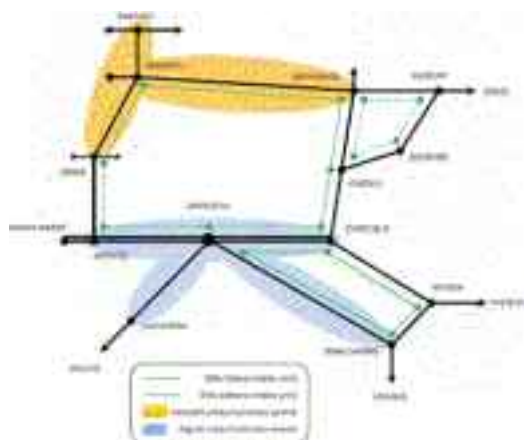
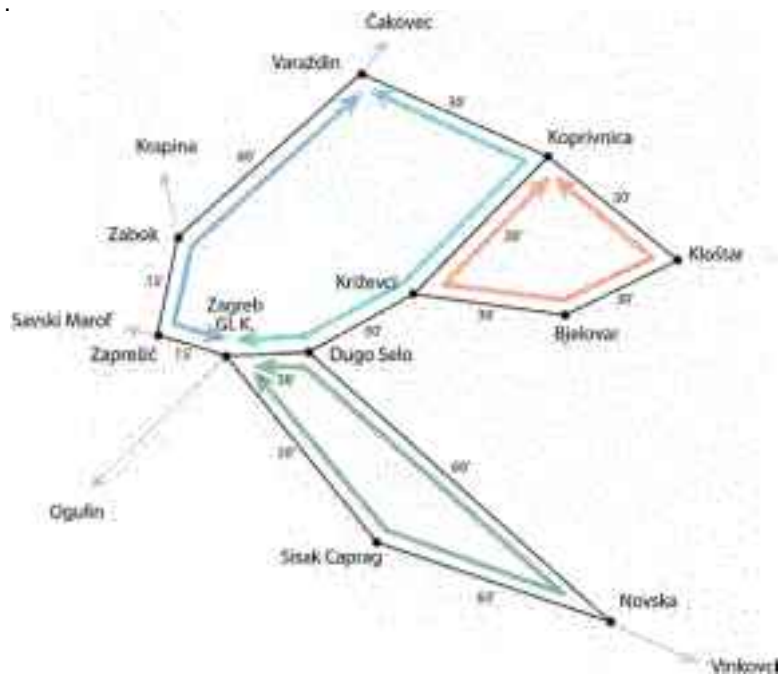

Figure 2 Urban/suburban service and proposal of regional service

Respectively, travelling times for the regional services would be 60–120 minutes between regional centers. Regional services are not meant to stop for passengers in the area of urban/suburban service trains except in final destinations on double line track. On single line tracks regional service trains would stop in stations with higher fluctuation of passengers. Considering the partial electrification of HŽ network and the extent of the investment needed for the full coverage of the central part of network, theoretical model was proposed as shown in Figure 2, using electric and diesel units. Diesel units are used westbound connecting Varaždin and Zagreb Main Station as a main hub. At least one stopping will occur, preferably in Zabok as the outskirts of the Varaždin–gravitating zone. That way it will offer quality and fast connection to Zagreb and at the same time provide trains passing. Eastbound main line offers electric haul, so it is proposed to use electric units for connections between Zagreb–hub and Sisak, Novska and Koprivnica. Considering the significance of the segment Varaždin–Koprivnica not just for regional, but also urban/suburban transport, electrification of the segment is inevitable and that fact is taken into account. The secondary eastern loop Koprivnica–Križevci via Bjelovar is designed also using DMUs.

### 3.2 Optimizing regional service for periodic timetable

The selected central region is connected in two main and one secondary loops (Figure 3). Figures near the sections represent travelling times between nodes. First loop connects Zagreb Main Station and Varaždin through east and west connection. The eastern node planned for passing trains is Križevci.



**Figure 3** Implementation of Periodic Timetable

Križevci is also connecting node along with Koprivnica with the secondary loop and Kloštar is selected node for passing trains. Zabok is already mentioned as passing point for the western line. Second main loop is Zagreb – Novska and symmetric point for passing is Novska.

Below are tables containing travelling times ( $t_v$ ) and traveling speeds ( $v_v$ ) enlisted in the HŽ Annual Network Report. There are also planned travelling times ( $t_p$ ) and travelling speeds ( $v_p$ ) for the same sections calculated for the Periodic Timetable. There are also shown differences in actual and planned travelling times with noticeable time savings in most sections.

Current traveling time for section Zagreb G.K.–Varaždin via Zabok is 130 minutes and planned travelling time with needed reconstructions is 90 minutes. 40 minutes saved is excellent contribution to competitiveness on this section (Table 1).

**Table 1** Zagreb G. K. – Zabok – Varaždin [5]

Section	$t_v$ [min]	$v_v$ [km/h]	$t_p$ [min]	$v_p$ [km/h]	$\Delta t$ [min]
Zagreb Gl.K. – Zaprešić	19	60–70	15	110	-4
Zaprešić – Zabok	29	60–80	15	140	-14
Zabok – Varaždin	79	40–80	60	90	-19

Current traveling time for section Zagreb G.K. – Varaždin via Križevci is 128 minutes and planned travelling time with needed reconstructions is 105 minutes (Table 2).

**Table 2** Zagreb Gl. K. – Križevci – Varaždin [5]

Section	$t_v$ [min]	$v_v$ [km/h]	$t_p$ [min]	$v_p$ [km/h]	$\Delta t$ [min]
Zagreb Gl.K. – Dugo Selo	19	80	30	90	+11
Dugo Selo – Križevci	23	50–140	30	90	-7
Križevci – Koprivnica	37	50–140	30	110	-7
Koprivnica – Varaždin	37	80–100	30	100	-7

Current shortest traveling time for section Koprivnica – Bjelovar is 128 minutes and planned travelling time with needed reconstructions is 105 minutes. It is also planned a 60 minutes service Koprivnica – Kloštar – Bjelovar that does not exist in current timetable (Table 3).

**Table 3** Koprivnica – Bjelovar – Križevci [5]

Section	$t_v$ [min]	$v_v$ [km/h]	$t_p$ [min]	$v_p$ [km/h]	$\Delta t$ [min]
Koprivnica – Kloštar	33	80–100	30	90	-3
Kloštar – Bjelovar	32	65–80	30	90	-2
Bjelovar – Križevci	34	65–80	30	90	-4
Križevci – Koprivnica	37	50–140	30	120	-7

Time savings in loop Zagreb G.K. – Novska are significant (Table 4.). Current shortest travelling time for section Zagreb G.K. – Sisak Caprag is 99 minutes, and planned travelling time for the Periodic Timetable is 30 minutes. For section Zagreb G. K. – Novska via Sisak Caprag is planned 90 minutes, and current timetable does not offer this connection. With some necessary reconstruction on section Zagreb G.K. – Novska via Dugo Selo instead of current 104 minutes, planned travelling time is 75 minutes and travelling would be shortened for 29 minutes. This model offers for instance, practical connection for passengers coming from Koprivnica or Kloštar via Križevci to Novska. They wouldn't need to go all the way to Zagreb to catch good connection, they could just transfer in the same 'takt' in Dugo Selo and save significant amount of time.



**Table 4** Zagreb G.K. – Novska [5]

Section	$t_i$ [min]	$v_i$ [km/h]	$t_p$ [min]	$v_p$ [km/h]	$\Delta t$ [min]
Zagreb G.K.–Sisak C.	60	50–140	30	120	-30
Sisak C. – Novska	99	60–80	60	90	-39
Novska – Dugo Selo	84	60–80	90	110	-24
Dugo Selo – Zagreb G.K.	19	80	30	90	+11

Time savings in loop Zagreb G.K. – Novska are significant (Table 4.). Current shortest travelling time for section Zagreb G.K. – Sisak Caprag is 99 minutes, and planned travelling time for the Periodic Timetable is 30 minutes. For section Zagreb G. K. – Novska via Sisak Caprag is planned 90 minutes, and current timetable does not offer this connection. With some necessary reconstruction on section Zagreb G.K. – Novska via Dugo Selo instead of current 104 minutes, planned travelling time is 75 minutes and travelling would be shortened for 29 minutes. This model offers for instance, practical connection for passengers coming from Koprivnica or Kloštar via Križevci to Novska. They wouldn't need to go all the way to Zagreb to catch good connection, they could just transfer in the same 'takt' in Dugo Selo and save significant amount of time.

## 4 Conclusion

Infrastructural network of HŽ is characterized by specific technical and technological parameters for exploitation and maintenance. This is of course reflected directly on level of service in passenger transport. Taking into account the mentioned fact, the opinion of the authors is that the only acceptable concept of the improvement of service level is complete separation of urban/suburban, regional and long distance systems in technical and technological aspect. The only technologically acceptable way of realization of this concept is high quality integration of passenger transport subsystems by means of Integrated Periodic Timetable. For that purpose a simulation of Periodic Timetable was conducted on a specific section of HŽ network and it derived several conclusions:

- key connecting nodes for the regional passenger transport;
- level of availability of track infrastructure;
- level of availability of station infrastructure.

Proposed conception showed sustainability of this approach in regional passenger transport and urban/suburban passenger transport on one section of the network and it's applicability on the rest of the network.

## References

- [1] Kräuchi, C., Stöckli & U. Popp: Mehr Zug für die Schweiz. Die Bahn-2000, First Edition, As Verlag, Zürich, Oktober 2004
- [2] Lichtenegger, M.: Der Integrale Taktfahrplan, Abbildung und Konstruktion mit Hilfe der Graphentheorie, Minimierung der Realisierungskosten. ETR 40, ,pp.171-175,1991
- [3] Veit, P., Mlinaric, T.J.: An integrated timetable for railways a beneficial solution for Central-Eastern -European-countries, CETRA 2010, Opatija, Croatia, p.p. 897-906, 2010
- [4] Studija opravdanosti investicije u nove prijevozne kapacitete-motorne vlakove, Putnički promet d.o.o.; Fakultet prometnih znanosti, BDO Savjetovanje d.o.o., Zagreb, 2011.
- [5] Izvješće o mreži 2013, HŽ Infrastruktura d.o.o., 2012.
- [6] Statistički ljetopis RH 2011, Državni zavod za statistiku, Zagreb 2011.

## **15 URBAN TRANSPORT PLANNING AND MODELLING**



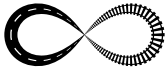

## INFRASTRUCTURE INVESTMENTS AND ITS IMPACT ON REGIONAL ECONOMY – EVIDENCE FROM TWO CASE STUDIES AS STARTING POINT FOR A PLANNING TOOL

Roman Klementschnitz

*Institute for Transport Studies, University of Natural Resources and Life Sciences (BOKU), Austria.*

### Abstract

Infrastructure investments in rail based systems, such as metro or regional railways, mainly are funded by public sector. Public sector spending needs justification before the tax payers. Traditional cost–benefit analysis is usually used to show the expected effects. However, results are often not satisfying as the expected benefit (user costs, travel time, emission, noise and safety) do not sufficiently cover the investments and operation costs in public transport projects. Effects on regional economy of the areas accessed such as increasing land value, follow up investments or increased consumption of users are usually not included in such analysis. The Institute of Transport Studies of the University of Natural Resources and Life Sciences (BOKU) Vienna, Austria, participated in several research projects (Interreg, EU–framework programme, national) where empirical data of such effects were explored through ex post analysis. Reference projects investigated are the new main railway station of Linz (capital of Upper Austria) and metro line U3 in Vienna. Follow up investments were compared with reference areas to identify different developments. Interviews with stakeholders (shop keepers, investors, etc.) were carried out especially to identify the cause and effect chains. In the Linz case users of the transport systems were interviewed to identify their consumptions at the station. In the Viennese case, data of real estate market was accessible to analyse effects in price developments of offices, shops or apartments. The presentation will give an overview of these results. Results show, these effects are very relevant as basis for decision for rail based infrastructure investment and need to be considered more deeply in future planning. Therefore, the Institute currently develops a calculation model for infrastructure measures as planning tool including land value effects and employment effects.

*Keywords: transport planning, rail based transport, evaluation schemes, socio economic effects.*

### 1 Introduction

Traditional cost benefit analysis for rail based infrastructure usually are considering variables such as investment – and operation cost, travel time, accidents, noise, emission, energy consumption and generated demand. Expensive investments such as rail based infrastructure usually do not exceed the necessary cost benefit ratio of 1 plus. But there is some evidence, especially long lasting rail based infrastructure in urban environment are also causing effects on labour market because of third party investment effects and on property market (increasing property values) because of improved accessibility, which will also be a stimulus to further investments. If considering these effects in the cost benefit analysis the decision of public investments could lead to other conclusions as practice shows today.

## 2 Ex Post Analysis of two case studies

Based on two reference cases ex post analysis were carried out to test the hypothesis, large scale infrastructure investments will have a significant effects on third party investments leading to positive employment effects and additional GDP effects. Another type of benefit is the change of land value because of the new infrastructure supply in the accessed areas.

### 2.1 Metro Line U3, Vienna (Austria)

Metro line number three was opened in different stages. In order to analyse long term third party effects only sections of the line were included in the analysis, they were opened before the year 1991 [1], [2]. To be able to identify third party effects of the investment, two strategies were followed: A micro approach with detailed data collection at site and a macro approach based on data on district level. The advantage of the micro approach is the use of unbiased and detailed data for analysis. The disadvantage is the missing availability of such data covering the whole city respectively the enormous time consumption to collect these data. The macro approach based on existing data bases can be done for the whole city but data are clustered not perfectly fitting to the needs for analysis and therefore can include effects of different other measures in the area as well.

#### 2.1.1 The micro approach:

For the micro approach three different areas were selected (see figure 1): The centre as the hot spot of the city. This area was accessed already before the access with the new metro line was established. It can be assumed this area is one of the most prosperous areas of the city and will act as potential upper limit of developments. The second area is located on the new metro line with access to two different stations. As a third reference area a region was chosen with the same distance to the city centre, comparable social situation, land use and reputation of the area but no access to any metro.

All the parcels of land of the three areas were investigated and classified in four categories: (1) no building exists (brown field area), (2) buildings are in poor condition (fully or partly uninhabited), (3) no investments were made in the period 10 years after opening of the metro line number three, but the condition of the buildings are quite acceptable and (4) newly constructed or mayor renovation works were carried out in this period. Results can be seen at figure 2. As expected, the city centre area shows the most dynamic situation all buildings are in acceptable condition, no building land is available in this area. The area with the new metro access shows a lower share of investments in the building stock, but a significantly higher rate comparing to the reference area without metro access. Contrary to this is the situation for unused land or buildings in problematic condition. This indicates a clear third party effect of the metro investment in the area under investigation. Based on the floor space of the affected buildings and classified after new construction, basic renovation (including technical infrastructure of the building) and light renovation (windows, facade only) the investment activities were transferred into money values based on standard values (see figure 3). Results are showing the investment per square meter is twice as high in the area with new metro access compared to the one without metro access.

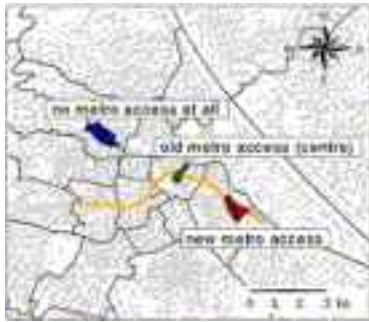

Figure 1 Map of areas of micro analysis, Vienna.



Figure 2 Investment activities in the areas of micro analysis, Vienna.



Figure 3 Investment rate in the areas of micro analysis, Vienna.

### 2.1.2 The macro approach:

For the macro approach the three districts were chosen, where the chosen areas of the micro approach were embedded, which are districts 01 (city centre), 03 (new metro access) and 17 (no metro access at all). Time series data of rents for dwellings, offices and shops based on district level were accessible for the analysis. Data were clustered for the period before and after the opening of the metro (10 years time period each). Rent prices were chosen as indicator as data were available due to the database of the office called Schlichtungsstelle, where renters can check their appropriateness of their rents. Additionally these values are reflecting both investment activities in better quality of the facilities and the better accessibility of a specific area. Results are shown in figures 4–6. In all districts a clear increase of the rents can be observed between the two time periods. Again the city centre (district 01)

shows the possible upper limits for the city of Vienna, which concerns all three categories. Comparing the development of the two other districts, it is interesting, that the district with new metro access (district 03) has overtaken the other district (17) in the two categories: rents for dwelling and for shops because of a more dynamic development. The price level for renting an office was higher in district number three already before opening of the metro, nevertheless the gap between the two districts raised. As stated before, there is some evidence, the new metro contributed to this development, but the cause-and-effect chain is more biased here in comparison with the micro approach.

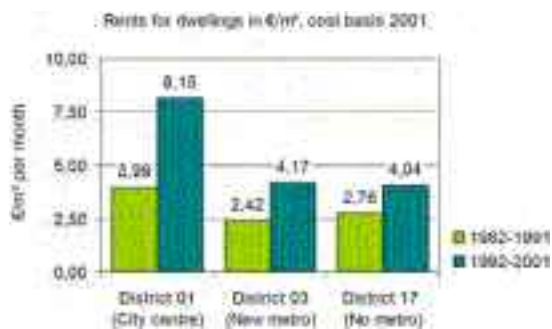

Figure 4 Development of rents for dwellings, macro analysis, Vienna.



Figure 5 Development of rents for shops, macro analysis, Vienna.

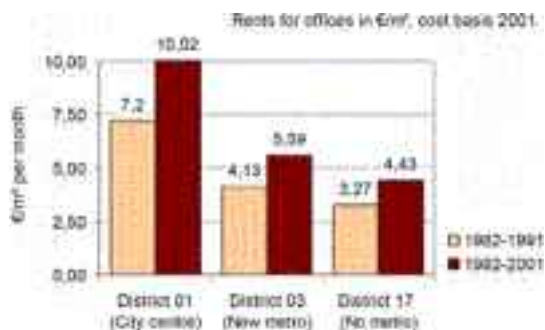

Figure 6 Development of rents for offices, macro analysis, Vienna.

## 2.2 Railway station in Linz (Austria)

As a second case study, the new railway station in Linz, capital of the province of Upper Austria was selected for analysis [3]. The station was totally new constructed, its accessibility with urban public transport was significantly improved and a shopping centre was integrated in the railway station building [4], [5]. The shift of the function from a pt-node only to a multi functional building could be shown based on interviews made at the station building (figure 7). Meanwhile only little less than 78% of people visiting the station are using the railways infrastructure whereas one third is carrying out shopping activities. Another 20% share is visiting the bars or restaurants and little less than 10% are using the station building for meetings. On average expenses of persons who have purchased goods at the railway station are € 9.80 (public transport related goods or services are excluded here). This equals ca. € 180 000 revenue per workday in the shops and bars within the railway station only [6]. Furthermore, the number of passengers using the railway station building increased from 27 600 trips per day to 46 700 trips per day within two years only (+70%) [6], [7].

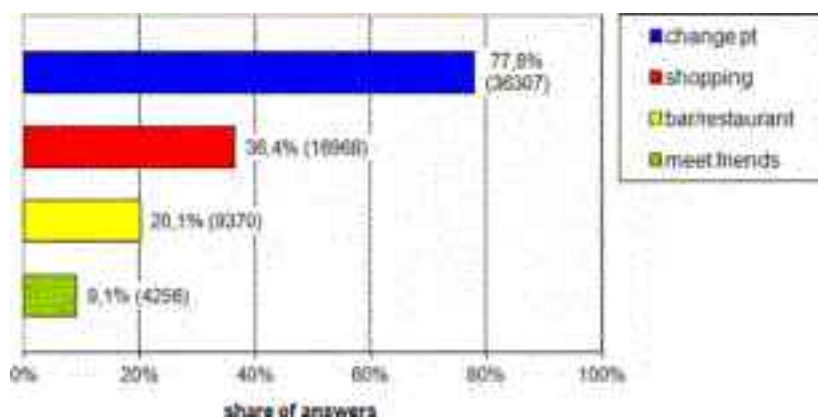

Figure 7 Purposes to visit the new pt node (multiple answers allowed), Linz.

Table 1 summarizes the main building developments within the area investigated (within a walking distance of 5 minutes from/to the station building), segregated after transport and non transport related investments. As the table shows the ratio of non transport related investments is three times higher in comparison to the transport related investments, even if one focuses on the main investments only. A lot of further investments – but of a smaller scale – were recorded in the area during a site visit but not crossed up to an investment sum here. A major problem, if analysing these developments is to determine causality within the cause and effect chain. Developers are clearly benefiting of the infrastructure upgrade, but in tendency denying the influence towards their decision to invest/settle down or not, when interviewing them. On the one hand, the availability of land to develop and the actual land use plans are further main drivers of these developments. On the other hand, investors want to avoid to start a discussion about implementing a beneficiaries tax to be paid by land developers to the public investor (as cases exists already, e.g. in Madrid conurbation, tram of Valdemoro case [8] or Cambridge, guided bus-way case [9]). For a cost benefit analysis, the estimation of the third party effects is difficult, especially as these effects are of great potential to influence the results of an investment and therefore the decision making process.



Table 1 Table 1. Main investment projects in the quarter of the railway station [10].

	Project	Investment sum	Workplaces	Opening date
Investment projects	Light railway station	- 43 Mio. €	150	12/2004
	Integration of light railway (LRT)	- 57 Mio. €		12/2004
	Integration of U-Bahn	- 10 Mio. €		12/2004
	Total	- 110 Mio. €	150	-
Other investments	Personnel administration centre (LRT)	- 140 Mio. €	> 1300	2005
	Tower of Knowledge (Library)	- 31 Mio. €		07/2007
	Head office of regional energy supplier Energie AG (Power Tower)	- 37 Mio. €	> 500	02/2008
	Administration building extension of U-Bahn	- 30 Mio. €	> 400	10/2009
	Terminal Tower (office building)	- 50 Mio. €		03/2009
	Total	- 288 Mio. €	> 2300	-

### 3 First attempts to develop a standardised model

In order to consider these effects identified in the case studies described above in future cost benefit analyses, during a PhD a model was developed [11]. Within this work, based on the developments in Vienna the effects on the labour market and property market were analysed and dependencies with regard to accessibility were formulated in algorithms. Input data for the estimation of effects on the labour and property markets are (1) changes in travel time both for public transport and private car as matrix between all cells in the catchment area of the investment, (2) the number of inhabitants per cell, (3) the number of workplaces per cell, (3) the number of floor space for housing in square meters per cell, (4) the average labour productivity per sector in the area and (5) the modal split of the city.

#### 3.1 Effects on Employment market

The additional jobs per year for the whole catchment area of the investment in relation to the changes of accessibility were multiplied with the labour productivity of each economic sector as follows:

$$\Delta av = \sum_w (\Delta emp \times lpr) [\text{Euros}] \quad (1)$$

- $\Delta av$  = change of added value per year [Euros/year]
- $\Delta emp$  = change of employment per year
- $lpr$  = labour productivity [Euros/employee]
- $w$  = cells of area
- 

Whereas the number of additional jobs can be calculated per cell based on:

$$\Delta emp = 196,75 + 13703,43 \times \Delta A \times P \quad (2)$$

- $\Delta emp$  = change to employment per year
- $\Delta A$  = change of accessibility of a cell based on changes in travel time
- $P$  = modal split share of public transport

### 3.2 Effects on Property market

The added values in the property market were modelled for the Viennese city in relation to the changes of public transport accessibility for the years 1991 and 2001. The derived algorithms to calculate the effects on the property market are:

$$av = \sum_{o=1}^n (pp_{o,with\_measure} - pp_{o,without\_measure}) \times fs_o \text{ [Euros]} \quad (3)$$

- av = added value [Euros]
- pp<sub>o</sub> = specific property price of a property transaction [Euros/m<sup>2</sup>], property in cell o
- fs<sub>o</sub> = living floor space in cell o

Whereas pp<sub>o</sub> of a cell can be calculated on absolute values, both for the situation with and without investment:

$$pp_o = 1458,06 + 0,002 \times A^2 \times P \text{ [Euros /m}^2\text{]} \quad (4)$$

- ΔA = accessibility of cell based on changes in travel time
- P = modal split share of public transport

## 4 Conclusions

The model was tested on a tram extension project for the city of Innsbruck (province of Tyrol) and results show a potential of added value of about 22 Mio €/a on the labour market and an increase of land values by 6 Mio €. If including these effects in the cost benefit analysis (which was carried out for this project), the cost benefit ratio would increase from 0.12 to ca. 1.60 [12]. This proves the statement introducing this paper that if including these effects the results of the cost benefit analysis leads to different results. A cost benefit ratio of 1 is the threshold if an investment is recommendable or not. Research on this issue is at a very early stage now and more case studies would bring in a clearer picture of these effects. Main obstacle for further analysis is the poor data situation to further improve the model. Additionally regional variance of the effects is not included so far in these first results as the data currently are based on Austrian case studies only.

## References

- [1] Sammer, G., Klementschtz, R., Roider, O. et al.: Urban transport and socio-economic development (TRANSECON). Final Report; Deliverable 7; Funded by: DG Transport and Energy (FP5), EC, Brussels 2004
- [2] Klementschtz R., Roider O.: Langfristige Auswirkungen von Investitionen in die Infrastruktur, Untersuchungen am Fallbeispiel der Wiener U-Bahnlinie U3. Der Nahverkehr, Offizielles Organ des Verbandes Deutscher Verkehrsunternehmen (VDV), 25. Jahrgang, 5/2007, pp 60-66; ISSN 0722-8287, 2007
- [3] Vougioukas M., Sammer G., Stark J., Klementschtz R., et al.: Transit systems development for urban regeneration (TRANSURBAN), Final Report. Co-funded by European Commission (INTERREG IIIc), Land Oberösterreich, BM für Wirtschaft und Arbeit und der Österreichischen Schieneninfrastruktur-Dienstleistungsgesellschaft mbH., Volos (Gr.) 2008
- [4] Basler+Partner, Siemens AG: Nahverkehrsprogramm für den Großraum Linz, Weiterführende Systemstudie, im Auftrag des Amtes der Oberösterreichischen Landesregierung, Basel, Linz 1999
- [5] Hager C., Schrempf R.: Die Nahverkehrsdrehsscheibe. Hauptbahnhof – Straßenbahnunterfahung, Landesdienstleistungszentrum, Verlag Denkmayr, Linz 2004
- [6] Klementschtz R., Stark J., Höfler L.: Der neue Hauptbahnhof Linz – seine verkehrliche Funktion und seine neue Rolle als innerstädtischer Wirtschaftsfaktor. Der Nahverkehr, Offizielles Organ des Verbandes Deutscher Verkehrsunternehmen (VDV), 26. Jg., 10/2008, 56-63; ISSN 0722-8287, 2008
- [7] Medox GmbH: 'Bahnhof Linz Frequenzzählungen und Infografik Umsteigerelationen – Tabellen' (unpublished document). Linz 1999
- [8] Oña, J., Calvo F. J., Garach L., Oña R., López G.: How to Expand Subway and Urban Railway Networks Light Rail Extensions in Madrid, Spain. Transportation Research Record: Journal of the Transportation Research Board, Publisher Transportation Research Board of the National Academies, ISSN 0361-1981, IssueVolume 2146 / 2010, pp 10-17, 2010
- [9] Vougioukas M., Sammer G., Monzon A.: Quality public transport systems in medium size cities: socio - economic development and urban regeneration impacts, funding and implementation advances. Association for European Transport (AET), Conference Proceedings; ISSN 1 474-9122, Leeuwenhorst (NL.) 2008
- [10] Stark J., Graf W., Klementschtz R., Sammer G.: Transit systems development for urban regeneration (TRANSURBAN), case study report Linz. Kofinanziert durch die Europäische Kommission (INTERREG IIIc), Land Oberösterreich, BM für Wirtschaft und Arbeit und der Österreichischen Schieneninfrastruktur-Dienstleistungsgesellschaft mbH, Wien 2007
- [11] Stark, J.: Analyse indirekter regionalwirtschaftlicher Effekte von ÖPNV-Infrastrukturinvestitionen gezeigt am Beispiel der Erweiterung des Wiener U-Bahn-Netzes 1991-2001. Dissertation at Institut für Verkehrswesen, 226 pages; Universität für Bodenkultur Wien 2010
- [12] Sammer G., Klementschtz R. (2011): Rankingmodell zur Evaluierung und Förderung von Umweltverbundmaßnahmen - Vorschlag eines Bewertungsverfahrens. Research report commissioned by Österreichischen Städtebundes, 52 p, Wien 2011

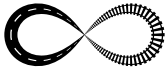

## THE IMPACT OF THE IMPLEMENTATION OF GREEN WAVE IN THE TRAFFIC LIGHT SYSTEM OF A TRAMWAY LINE –THE CASE OF ATHENS TRAMWAY

Christos Pyrgidis, Martha Chatziparaskeva  
*Aristotle University of Thessaloniki, Greece*

### Abstract

One of the key parameters, which determine the quality of service provided to the users of a tramway system, is travel time. The duration of travel and therefore the resulting commercial speed depend on the type of tram corridors, the length per corridor type, the distance between successive stops and the priority given to the tram at road and pedestrian crossings controlled by traffic lights. This paper focuses on the investigation of the impact of the green wave implementation in the signalling system of a tramway line. In this framework a) the different signalling systems adopted in tramway networks all over the world are described as well their impact on travel duration is analysed and compared b) the impact of giving priority to tram at traffic lights, on its commercial speed and for different scenarios of corridor typology, is examined, using empirical mathematical formula c) moreover, the recent implementation of the green wave policy in Athens' tramway system is examined and its impact on travel duration is evaluated, based both on in situ collected data and on international standards. According to the results of this work, a) if priority is given to the tram at traffic lights then the duration of travel can be reduced by 5%–35 %, b) Athens tram system has achieved reduction of travel time up to 19% regarding the different track sections of the network c) further reduction in travel times in Athens tram system can be achieved by additional interventions, regarding the signalling system, the type and the protection of corridors and the distance between stops.

*Keywords: tram signalling system, Athens tramway, green wave; commercial speed*

### 1 Introduction

One of the key parameters that determine the quality of service provided to the users of a tramway system is travel time. Short duration of travel makes tram much more attractive to the passengers and contributes to the increase of its potential patronage. The duration of travel and consequently the commercial speed of the trains depend on many parameters and mainly on the type of tram corridors, the length per type, the distance between successive stops and the traffic signalling system, along the tram corridor and at road and pedestrian crossings. (Commercial speed is defined as the quotient of covering distance towards total travel time, including delays and waiting time at stops).

This paper focuses on one of the above parameters. More, specifically, it investigates the impact of giving priority to trams at traffic lights, on travel time and on commercial speed achieved along a line. In this framework, this paper:

- Attempts to quantify the increase of commercial speed which can potentially result from giving priority to trams at traffic lights. This effort is based on data from different tramway networks and on empirical mathematical formulas.

- Investigates the interventions recently implemented in the signalling system of Athens' tramway network and evaluates them by comparing recent with previous travel times.
- Quests and proposes additional measures that can contribute to a further increase of commercial speed recorded in Athens' tramway network.

At this point, it should be mentioned that Athens' tramway network started its commercial operation in the summer of 2004 and it renders transport services in the city of Athens and in a broader area, in combination with metro, trolley and urban buses. However, a part of potential users of Athens' tramway network are not satisfied with offered service level. They declare that the major cause is the low commercial speed and therefore long travel time.

In July 2010 a study proposing changes in the signalling system of the tramway of Athens was released. These changes aim to give priority to trams relative to road vehicles during their passage through signalling intersections. These changes were completed in winter 2011.

## 2 Tramway signalling system basic principles

The basic principles of tram signalling systems are that a) priority at traffic signal locations should be given to trams and b) at level crossings; there should be collaboration between the different signalling systems intended for trams, road vehicles and pedestrians.

Referring to traffic lights priority for trams, there are two strategies:

- **Passive Traffic Signal Priority:** In these systems, traffic lights are set to turn green based on an average tram speed. In other words, the detection of a tram at crossings with traffic lights is not necessary. Priority is given by a standard procedure: favourable cycle time – favourable green time at each phase of the cycle time – coordination.
- **Activate Traffic Signal Priority:** In this strategy, the approaching tram sends a signal to the traffic signal controller to change in predefined limits the signal in its favour. The traffic signal priority is more effective than the passive traffic signal priority, as it is based on a dynamic response to a transit request.

There are four types of activate traffic signal priority systems: [1], [2], [3].

- Dedicated Priority – Phasing Changes
- Longer Green Time
- Phase and Timing Adjustment
- Intelligent Transport Systems Approaches

Collaboration among traffic signalling systems is extremely necessary, as a lack of coordination can result in delays for other vehicles. The frequency of interruption of signalling in favour of trams affects the recovery time of a signalized intersection.

### 3 Quantification of signalling impacts on travel time and on commercial speed of trams

#### 3.1 Estimation of the impact of giving priority to trams at traffic lights based on data from different tramway networks

Table 1 gives, indicatively, different signalling systems adopted in tramway networks all over the world and their impact on travel time of both trams and the rest involved traffic.

**Table 1** Tram signalling systems and their impact on traffic [4]

Signaling system– Place of implementation	Strategies of giving priority to trams	Impact
BALANCE – Munich	Phasing changes– Longer green time	Reduction of travel time by up to 14% for both trams and the rest traffic
UTOPIA –Torino	Improvement based on existing traffic conditions	Reduction of trams' travel time in the range of 15%–25%
SPOT–Gutenberg, Europe, USA	Giving priority to trams using algorithms that don't take into account traffic congestion.	Reduction of trams' travel time in the range of 5%–15% – No impact on other public transport vehicles
TUC–Southampton, Tel Aviv, Jerusalem	Maintenance of phases and timing– Maintenance of phases – Phase and timing adjustment	Reduction of trams' travel time by up to 33.3%
SCATS–Melbourne	Combination of activate and passive traffic signal priority	Reduction of trams' travel time in the range of 6%–10%. Reduction of 1%–7% for the rest traffic
Stuttgart	Longer green time–Full priority	Reduction of trams' travel time by up to 50% and short delays on the rest traffic
Zurich	Priority by detection of the approaching tram B	Minimization of trams' delays at signalized intersections

#### 3.2 Estimation of commercial speed using empirical mathematical formula

Table 2 (columns 1, 2, 3) gives the commercial speeds of a tramway for different types of tram corridors, as they resulted empirically from both measurements and the following assumptions: [5], [6]

- The average distance between two successive tram stops is 500m.
- The average time of stopping at each stop for passenger embarkment and disembarkment is 20 sec.
- No priority is given to trams at traffic lights.

The commercial speed is calculated on the basis of equations (1) and (2):

$$I_E / V_E + I_D / V_D + I_C / V_C + I_{B-} / V_{B-} + I_B / V_B + I_A / V_A = t \quad (1)$$

$$V_{com} = S / t \quad (2)$$

Where  $s$  is total routing length;  $t$  is total routing travel time,  $V_{com}$  is commercial speed;  $I_E, I_D, I_C, I_{B-}, I_B, I_A$  represent length of track section with type of corridor corresponding to E, D, C, B-,B, A;  $V_E, V_D, V_C, V_{B-}, V_B, V_A$  represent commercial speed corresponding to corridors of category E, D, C, B-,B and A.

**Table 2** Commercial speed for different types of tram corridors (with and without priority to trams at traffic lights) [5], [6]

Name of tram corridors	Type	Commercial speed (without priority at traffic lights) (km/h)	Commercial speed (km/h) resulted from priority to trams at the traffic lights (+15%)	Commercial speed (km/h) resulted from priority to trams at the traffic lights (+25%)
(1)	(2)	(3)	(4)	(5)
Common	E	12–15	12–15	12–15
Separated corridor	D	17.5	20.125	21.875
Exclusive tram corridor	C	18–20	18–20	18–20
Reserved protected corridor with degraded characteristics of separation	B-	18.5	21.275	23.125
Reserved protected corridor	B	20	23	25
Fully exclusive corridor	A	30	30	30

### 3.3 Estimation of the impact of giving priority to trams at traffic lights based on a combination of 3.1 and 3.2

Based on the data in table 2, it can be easily concluded that a travel time reduction in the range of 5%–35% can be achieved by giving priority to trams at traffic lights. This reduction corresponds to an increase of the trams' commercial speed in the range of 5.26%–53.8%. According to other researches, the commercial speed of a tramway can increase by up to 35% by giving priority to trams at signalized intersections.

Taking into account these data, a 15%–25% increase in commercial speed seems to be a reasonable expectation. Table 2 (columns 4 and 5) gives the commercial speed, determined empirically, after having considered that the tram is given priority at traffic lights on types B-, B and D of tram corridors. (At trams running on types E and C cannot be given priority, whereas priority is given on type A, as the trams run on a completely exclusive corridor.) [5], [6]

## 4 The impact of giving priority to Athens' tramway system

### 4.1 Network's condition before signalling changes

The tramway network of Athens has a  $\tau$  formation [7], [8]. It connects the centre of Athens (Syntagma) with Paleo Faliro, via Nea Smyrni and it branches off along the Seaside Avenue towards Alimo, Elliniko, Glyfada and Voula on one side and towards Faliriko Delta and Neo Faliro (SEF) on the other. Athens' tramway network has a total length of 24.260 km and includes the following 3 lines:

- Line 3 (Thoukydidis): SEF–Voula – length 15.964 km with 31 tram stops
- Line 4 (Aristotelis): SEF–Syntagma – length 14.155 km with 28 tram stops
- Line 5 (Platonas): Syntagma–Voula – length 18.474 km with 37 tram stops

Lines 4 and 5 include a common section: 'Syntagma–Mousson'. This section crosses densely populated areas, while the 'SEF–Voula' section runs near (or along) the Saronic Gulf Coast [7], [8].

Table 3 gives the length of each type of tram corridor for the whole network and table 4 gives length, types of tram corridors, travel time and commercial speed for the 3 lines and for 3 sections of the tramway network. The data in table 4 resulted from measurements taken in March 2010 (tram was given priority at 15 out of 81 signalized intersections). In addition to the data in tables 3 and 4 data, it is notable that:

- It was planned that tram would run on the type B tram corridor (reserved and protected) along the L. Vouliagmenis–Mousson section. However, this does not happen because pedestrians encroach upon the tram corridor. This problem is also noted on the SEF– Voula route, but to a smaller extent.
- The average distance between two successive stops is 516 m, but there are successive stops placed at a shorter distance (383 m), mainly in sections in urban area (the L. Vouliagmenis–Mousson section)
- There are 264 points where the tram intersects with pedestrian or vehicular flows. The tram should pass through these intersections carefully and at a low speed. Even if these intersections coincide to a large extent with pedestrian crossings, and even if these points are reduced to 120, the tram encounters difficult points along its route, or difficult points of intersection with other vehicles or with pedestrians, every 200 m on average.
- Commercial speed in the Syntagma–Mousson section is 14.39 km/h (8.5% of the total length is tram corridor type E, 11.2% of the total length is tram corridor type D, 55.7% is type B-, and 24.6% is type B). According to equations 1 and 2 and table 2, commercial speed could potentially increase to 20.52 km/h, supposing that priority is given to the tram at all signalized intersections (this represents a 15% increase in commercial speed). On the contrary, in coastal section SEF–Voula, the commercial speed is at about 23.2 km/h, and this is regarded as satisfactory (44% of the total length is tram corridor type B- and 56% of the total length is tram corridor type B). Assuming that priority to the tram increases commercial speed by 25% the speed could potentially increase to 24.18 km/h.

**Table 3** Athens' tramway network – Length of each type of tram corridor [9]

Corridor type	E	D	B-	B	Total
Length (m)	710	930	11,640	10,980	24,260
Percentage %	2.9 %	3.8 %	48.0%	45.3	100%

**Table 4** Travel time and commercial speed in sections of Athens' tramway network (March 2010) [9]

Line/ section	Length (km)	Type of tram corridor	Travel time (min)	Commercial speed (km/h)
Line 4: Syntagma– SEF	14.155	B,B- ,D ,E	50.1	16.95
Line 5 : Syntagma–Voula	18.474	B,B- ,D ,E	62.4	17.76
Line 3 : SEF–Voula	15.964	B , B-	41.3	23.19
Section Syntagma–L. Vouliagmenis	1.548	D , E	7.0	13.26
Section L. Vouliagmenis–Mousson	6.513	B, B- , D	26.6	14.69
Section Syntagma–Mousson	8.061	B,B- ,D ,E	33.6	14.39



## 4.2 Network's condition after changes to the signalling system

Following changes in signalling, trams are given priority at 73 out of 81 signalized intersections. The intersections where changes in signalling were implemented are primarily in urban area (Syntagma–Mouson section). Moreover, changes regarding the distance of the tram's detection and the distance of the priority requests have been made, and many technical problems of intersections have been addressed. The signaling system of Athens' tramway network is a combination of Balance system (Munich) and of the system applied in Stuttgart. In August 2011, measurements of the travel time of 12 routes (these 12 routes pertain to 3 lines of tramway network) were taken. The purpose of these measurements was to pin point the impact of signalling changes on travel time and on commercial speed. New travel time has been compared with the travel time measurements of March 2010. Table 5 gives the results of this comparison, which refer to both travel time and commercial speed.

There is a reduction in travel time at all sections. The largest reduction (18.87%) is recorded in the urban area (Syntagma–Mouson section), and the smallest reduction (5.25%) is recorded on the SEF–Voula line. Likewise, there is an increase in commercial speed – increases of 15%–18% were noted on lines 4 and 5, where the tram runs through the urban area, whereas commercial speed has increased by 5.52% on line 3: SEF–Voula (coastal section). An increase of 23.28% has been recorded for the urban Syntagma–Mouson section.

**Table 5** Comparison of travel time and commercial speed on lines and sections of Athens' tramway network – March 2010/ August 2011

Line/ section	Travel time (min) (March 2010–without priority)	Travel time (min) (August 2011–with priority)	Variation according to March 2010	Com. Speed (km/h) (March 2010–without priority)	Com. Speed (km/h) (August 2011–with priority)	Variation according to March 2010
Syntagma–SEF	50.1	42.4	-15.36%	16.95	20.03	+18.17%
Syntagma–Voula	62.4	54.3	-12.91	17.76	20.39	+14.80%
SEF–Voula	41.3	39.1	-5.25%	23.19	24.47	+5.52%
Syntagma–Vouliagmenis	7.0	6.1	-12.43%	13.26	15.15	+14.25%
Vouliagmenis–Mouson	26.6	21.1	-20.56%	14.69	18.49	+25.86%
Syntagma–Mouson	33.6	27.3	-18.87%	14.39	17.74	+23.28%

## 4.3 Additional interventions for the increase of commercial speed

The latest data of commercial speed on the SEF–Voula route, as recorded in table 5, seem to be satisfactory. On the contrary, commercial speed should increase on the Syntagma–Mouson route. The suggested interventions for additional improvements to the service level provided to the users of the Athens' tramway system are as follows:

- 1 Completion of the implementation of giving priority to tram at all signalized junctions. This measure will reduce travel time on the Syntagma–Mouson section by up to 1 minute.
- 2 Reduction of the number of stops on the L. Vouliagmenis – Mouson route is advisable.
- 3 Ensuring of the operation of corridors where trams run, according to the typology for which they are planned to operate (convention of type B- tram corridor to tram corridor of type B).
- 4 Construction of a separated and protected tram corridor along the Syntagma–Mouson section (convention of type D tram corridor to tram corridor of type B). – Interventions 3

and 4 would likely reduce travel time by up to 5 minutes.

5 Better marking of the tram's presence.

If these interventions are implemented, commercial speed on the Syntagma–Mouson section would increase from 17.74 km/h to 21.70 km/h

## 5 Conclusions

The conclusions resulting from this study regarding the signalling system of a tramway network generally, and the signalling system of Athens' tramway network specifically, are the following:

- There are many different signalling systems that are adopted in tramway networks all over the world that give priority to trams vis-à-vis other vehicles during their passing through signalized intersections. According to the data of examined systems, giving priority to trams at traffic lights can increase commercial speed by 5% to 50%. An increase of 15%–25% seems to be realistic.
- The strategy of giving priority at signalized intersections to the trams of Athens' tramway network resulted in a reduction of travel time in all sections. The largest reduction (18.87%) is recorded in the urban area (Syntagma–Mouson section), and the smallest reduction (5.25%) is recorded on the SEF–Voula line. Correspondingly, the increase of commercial speed is up to 23.28% (from 14.39 km/h to 17.74 km/h) on the Syntagma–Mouson section and up to 5.52% (from 23.19 km/h to 24.47km/h) on the SEF–Voula line.
- Additional interventions can further increase commercial speed in urban area.

The results of this paper determine the actual operational capabilities of Athens' tramway network and define the framework for their achievement. Users of urban transport in Athens should be aware of these capabilities in order to encourage tram use over other transport means.

## References

- [1] Transit Signal Priority. Give buses and trams priority at traffic signals, [wiki.greencitystreets.com](http://wiki.greencitystreets.com)
- [2] Traffic signals: Public Transport Priority, [streetswiki.wikispaces.com](http://streetswiki.wikispaces.com)
- [3] Stathopoulos, A. & Pyrgidis, C.: Principles of tramway networks signaling systems and integration in the general urban signaling systems, Scientific Workshop, National Technical University of Athens /University of Crete, Athens, 2005
- [4] Fox, K., Chen, H., Montgomery, F., Smith, M. & Jones, S.: Selected Vehicle Priority in the UTMG Environment, project funded by the Department of the Environment, Transport and the Regions in UK.
- [5] Pyrgidis, C.: Light rail transit integration into urban areas', Rail Engineering International, No 1, pp. 12-16, 2003.
- [6] Bieber, A. : Les choix techniques pour les transports collectifs, École Nationale des Ponts et Chaussées, Paris, 1986.
- [7] [www.tramsa.gr](http://www.tramsa.gr)
- [8] Pyrgidis, C. & Stathopoulos, A.: The new light rail transit system of Athens, Greece, Rail Engineering International, No 4, pp. 6-10, 2004.
- [9] Chatziparaskeva, M.: The impact of the implementation of green wave in the traffic light system of a tramway line – The case of Athens' tramway, Master thesis, Civil Engineering Department, Aristotle University, Thessaloniki, 2011.



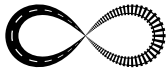

## PROGRAM FOR DEVELOPMENT OF BICYCLE TRAFFIC IN THE CITY OF ZAGREB

**Marijan Ključarić<sup>1</sup>, Krunoslav Tepeš<sup>1</sup>, Hrvoje Pilko<sup>2</sup>**

*1 City of Zagreb, City Office for Physical Planning, Construction of the City, Utility Services and Transport, Department for Transport and Roads, Croatia*

*2 University of Zagreb, Faculty of Transport and Traffic Sciences, Department for Road Transport, Croatia*

### Abstract

The City of Zagreb, like most of the European cities and cities in developed countries, experienced a rapid motorized growth. On a long term, this cannot be successfully solved by building an infrastructure which is exclusively designed for individual motorized traffic. By following recommendations and guidelines of the European Commission, relating to the future sustainable development of cities and the mobility of their inhabitants, as well as positive examples of European cities and regions, the City of Zagreb, in the last 10 years, increasingly commits to and directs the development of alternative forms of transport. This primarily refers to urban public passenger transport and the development of bicycle traffic. Taking this into account, this paper contains a review of previous program activities and future plan actions relating to the development of bicycle traffic in the City of Zagreb, mainly relating to: development and arrangement of bicycle traffic network, establishment of a public bicycle service, innovation and adaptation of legislation related to design of bicycle paths and lanes, and general safety of bicycle traffic.

*Keywords: bicycle path / lane, bicycle rack, public bicycle service, legislative regulations, European and international examples and guidelines*

### 1 Introduction

In recent years, City of Zagreb, as most European and world capitals, increasingly experiences negative consequences of a permanent increase in the volume of individual motor traffic. This ultimately results in increased noise, emissions of toxic gases and significant deterioration of climatic conditions and quality of life of its citizens.

Despite the continuous rise of individual motorized transport, the city also recorded an increased share of bicycle traffic in the overall travel. Apart from the general recession impact, the level of development and quality of cycling areas is also responsible for the increased number of bicycle users in the cities.

Appeal for bicycle traffic is increased by systematic expansion of cycling network, upgrade and adaptation of new lanes and connections and the installment of bicycle racks. Unfortunately, this also increases the security risk of bicycle traffic.

Pursuant to the above, this paper will analyze the existing regulatory legislation, current cycling infrastructure, features and characteristics of the problem situation, from the standpoint of the volume of bicycle traffic. The result will be used as a foundation in the process of drafting the program for bicycle transport development in the area of Zagreb.

## 2 Features of bicycle traffic in the City of Zagreb

Following recommendations and guidelines of the European Commission, which are relating to the future sustainable development of cities and the mobility of their inhabitants, as well as positive examples of European cities and regions, Zagreb is, in the last 10 year, increasingly opting for the development of alternative forms of transport, primarily for the urban public passenger transport and the development of bicycle traffic. Accordingly, for the last 15 years, there are ongoing measures to improve and encourage bicycle traffic in the overall travel, in order to increase its participation and limit motor traffic, prevent environmental pollution and to promote generally healthier life for citizens.

Systematic planning of bicycle traffic in the city dates to the mid 80s, when the Master Plan (GUP), in which bicycle traffic corridors were planned. was first adopted. At the beginning, the bicycle traffic and bicycle-oriented surfaces were intended exclusively for recreational and sporting purposes. Jarun is one of the first examples of building biking trails for recreational and sporting purposes in the City of Zagreb (bike path around Jarun was arranged before the Univerzijada 1987). From 1995 to 2010, there was a gradual approach towards the future network planning of bicycle lanes and trails, by renewing the existing and building the new ones, as well as equipping certain zones and locations with bicycle racks. During this period, approximately 220 km of cycling trails were renewed and built. Plotting bicycle paths / lanes began on the city's main roads, whose cross section was sufficient for the interpolation of bicycle paths and for which there was no need to accede major construction projects.

In order to adapt the existing transport infrastructure to the needs of the safe flow of bicycle traffic, regulation of bicycle areas also entailed the creation of specific design solutions of the reconstruction. In the previous period, City of Zagreb undertook a number of other traffic technical and regulatory interventions with the aim to improve conditions for bicycle traffic such as:

- removal of urban and architectural barriers (suspended curbs and construction of suspended ramps),
- adaptation – addition of signaling equipment on the intersections controlled with traffic lights (the introduction of LED lanterns for cyclists)
- marking of cycling areas with red filled (infill) lanes in the full profile, made of thermoplastics, in the areas of high traffic density,
- installation of fixed / flexible protective pillars and staples for the protection of bicycle paths,
- construction of bicycle path or lane during reconstruction and major road repairs.



Figure 1 Setting of traffic signs and equipment for the regulation of bicycle traffic in the City of Zagreb

## 2.1 The amount of bicycle traffic

First official data regarding the volume of bicycle traffic was recorded and released in a traffic study of City of Zagreb [9], prepared by the famous English design and engineering consultancy firm MVA in the year 1999. The research covered in this study shows that only 0.7% of the daily journeys are realized by bicycle. In this study, bicycle is classified as an underutilized mean of transport. However, it is interesting to note that 51% of households said that they have at least one bicycle, which represents a respectable potential for greater use of bicycles as a mean of travel.

Before the above mentioned traffic study, there was no comprehensive study of the transport demands or traffic volume measurements which could, by using the same pattern, be used as a basis for conclusions regarding changes in the participation in the actual daily journeys. There were, however, several measurements and surveys performed on a limited number of locations and selected population, which provided an approximate image for certain characteristic of the intensity of bicycle traffic.

In the study performed by the collaborating company ISIP-MG [1], a measurement of traffic at 16 locations was carried out, mostly on the city's busiest traffic corridors. This data is presented in the following graph (Figure 2). Based upon these limited measurements, it can be assessed that there is a certain amount of increase in bicycle traffic. This can be attributed to the major traffic infrastructure adaptations regarding bicycle traffic.

## 2.2 Cycling infrastructure

Most cycling routes (90%) are arranged as bicycle lanes on the pavements of urban roads, separated from the pedestrian walkway with color or in small part with the shallow curbs. Exceptionally, in the central part of the city, on one of the main longitudinal roads, a bicycle lane is established in the roadway profile of the road, in the length of approximately 1300 m. Separate bike paths are arranged only within the sporting and recreational complexes. The prevailing solution of bicycle routes on sidewalks was not met with enthusiasm from the cycling population. This is due to the fact that this solution exposes them to conflicts with pedestrians. Consequently, these solutions should be used only in the corridors of roads with the low intensity of pedestrian traffic. Parallel with the regulation of bicycle paths and lanes, and with the enhancement of bicycle traffic intensity, there was a need for additional cycling infrastructure in terms of bike rack and standpoints.

In recent years, there was a particularly intensive planning and equipping of bicycle parking lots. Initially, the zones within public institutions have been equipped with bicycle holders in the central part of the city. This encompassed approximately 50 locations. On the initiative of the owners and users of commercial services, a large number of sites was equipped with racks. One of the most problematic features in the network of bicycle paths in Zagreb is its lack of interconnectedness into the compact network.

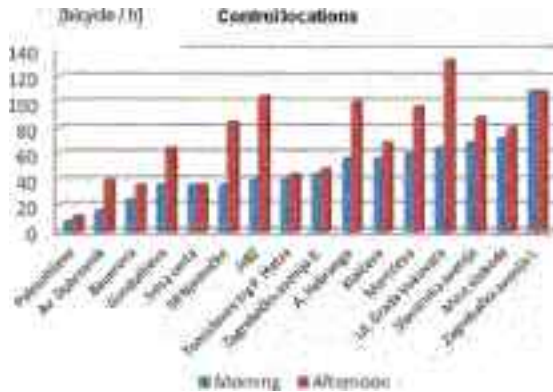

Figure 2 Hourly amount of bicycle traffic on the control locations

### 3 Development and improvement of bicycle traffic in the City of Zagreb

Development and improvement of bicycle traffic in the city of Zagreb will be focused upon interventions that can be defined through the following program components:

- improving conditions in the existing bicycle network,
- further development and expansion of bicycle paths or lanes,
- implementation of the public bicycle service,
- amending legislation regarding regulation of bicycle traffic.

#### 3.1 Program to improve conditions on the existing bicycle network

Within this program, it is necessary to establish conditions for the smooth flow of bicycle traffic on the existing cycling routes. This includes completion and restoration of traffic signals, connecting bike trails when there is an interruption in their continuity, lowering of the curbs in intersections and installation of signaling equipment on intersections adapted to the needs of bicycle traffic.

As a part of this program, it is necessary to remove all flaws and inconsistencies which are not compatible with the reality of the traffic situation on the field. First of all, this refers to the positioning of the bicycle lane within the road profile, the width of the lane, crossing the lane or path through the intersection etc.

Figure 3. shows examples of typical problem situations, such as: unfavorable positioning of utility infrastructure within the corridor of bicycle lanes, ignoring the need for lowering the curbs when building roads, unadjusted guidance of bicycle lanes through the intersection and more.



Figure 3 Deficiencies and inconsistencies in the existing bike paths and lanes which should be removed

### 3.2 Expansion of bicycle lanes or paths

In the foreseeable planning period, of 15–20 years, it would be realistic to try to complete the network of bicycle routes planned by the city General master plan, which relates primarily to the regulation of bicycle routes within the corridors of the city's main roads.

Assuming equal development of future network, this would mean expanding the network of bicycle lanes for 5–7 km per year.

In this period, there will certainly be a need for regulation of bicycle lanes and paths on the road corridors of minor importance as these are, seen from the perspective of local areas, urban settlements or districts, recognized as potentially attractive cycling routes. These are the routes of the roads that connect building blocks with public amenities; schools, sport and recreational centers, etc.

In the further expansion of the cycling network in the City of Zagreb, priority certainly belongs to directions and sections of the city center, which are not properly connected and in the areas where the integrity and continuity of a given direction is not ensured.

Within this central part of the network, the most important are the parts of the lanes by which the bicycle stops of the bicycle service would be connected, as that is a prerequisite to the future establishment of the mentioned service.

Expansion of the biking network from the city center to the periphery, should be implemented as a part of the reconstruction and increased maintenance of the roads. During these activities, it is possible to intervene in the construction works and thus ensure the necessary profile for the bicycle path, by reallocating or correcting parts of the profile or by expanding the corridor outside of the existing regular line.

### 3.3 Implementation of the public bicycle service

For a number of years, city's program documents indicate the need to establish public bicycle service. Relating to this topic, city offices started certain preparatory activities directed towards gathering various experiences in launching and operating public bicycle service.

A convenient and illustrative study was made, documenting certain European and other international experiences regarding launch and implementation of public bicycle service.

Visits and talks about specific experiences of Vienna and Ljubljana were carried out, and this indicated that the most successful public bicycle service is the one established and operated on the principle of public–private partnerships, or based upon granting concessions to companies whose core activity is related to the media, propaganda and marketing activities. Cities normally give such companies the right to use 'for free' attractive advertising space for a number of years (20 years and over). In return, media company equips and maintains functionality of the city's public bicycle service within the concession period.

It refers mainly to the technical, technological and IT-wise high level of supply and reliability in the operation, which faces a positive response and approval from the citizens. In addition, cities that have modern and reliable public bicycle service are provided with the image of cities with high awareness of environmental and energy efficiency.

The basic role and importance of such a modern bicycle service relates to the promotion of a new life attitude towards the environment and the impact on behavioral change in citizens regarding the selection of means by which they travel.

### 3.4 Amending legislation regarding regulation of bicycle traffic

Since the traffic police reports have not registered alarming statistical indicators regarding road accidents and casualties of cyclists in the current low intensity bicycle traffic, it was considered that there is no need or justification for changes in this field. Consequently, the 'Law on Road Traffic Safety', which was so far amended on couple of occasions, mainly remained



unchanged in this section. However, the current regulations governing the area of bicycle traffic are not adequately adapted to the situations of intense bicycle transport in neither urban areas nor in general.

To ensure proper conditions for future expected growth of bicycle traffic, it will be required to intervene in the area of its control. The mentioned normative interventions must be made in the areas of planning and designing of cycling infrastructure, as well as in the planning of bicycle traffic and amendments to the regulations regarding the safety of bicycle traffic.

In the area of planning and designing the bicycle infrastructure, there is a lack of quality project instructions and guidelines for designing bicycle paths or lanes, mostly in the part that defines the position of a given bicycle path or lane within the road profile. There is no regulation or recommendation on guiding the bicycle paths through an intersection, and no regulation regarding the width of the lane with regards to the intensity of bicycle traffic. Furthermore, regulation is non-existent in regard to the designing traffic light plans or the amendment of the traffic signaling equipment needed for bicycle traffic.

There is a need to intervene in the traffic regulation relating to the bicycle traffic safety, mostly in regard to the 'Law on Road Traffic Safety' and relevant by-laws that accompany it. Mentioned interventions are necessary regarding areas relating to the prevention of potential security risks in terms of prescribing rules of behavior, speed limits, rules on giving priority, and in the following security risk situations and relationships among participants:

- relationship between cyclists and pedestrians, on the sidewalk where the established bike paths are located,
- relationship between cyclists and drivers of motor vehicles, on the road surface where the bicycle lanes are established,
- the relationship of cyclists / pedestrians and cyclists / driver of the vehicle, in crossing over traffic light controlled and uncontrolled intersections,
- movement of cyclists in the pedestrian zone,
- movement of cyclists at night and in poor visibility,
- equipment and functionality of bicycle,
- driving skills and knowledge of traffic regulations.

Future increase in the use of bicycle, as a mean of transport for daily travel, needs to be properly addressed when designing residential and other buildings.

It is the fact that the existing residential buildings generally do not have enough common usable space for keeping bicycles. Consequently, in regard to their future design, it should be obligatory that apartment buildings provide adequate space to hold at least one bicycle per flat unit up to 50 m<sup>2</sup>, and relatively larger space for larger flats.

## 4 Conclusion

In the context of achieving the preconditions for sustainable development of transport in the City of Zagreb, it is necessary to encourage the promotion of various forms of transportation that are alternatives to individual motorized traffic.

One of these alternative forms of transport is cycling. Its development must be intensified by continuous adaptation and regulation of transport infrastructure, by upgrading the cycling network, by linking existing bike corridors, realizing the project of public bicycle service and by conducting preventive activities.

All of the above mentioned measures, aimed at improving bicycle traffic, should provide conditions in which the bicycle traffic becomes a respectable form of daily travel. Consequently, its share in the total number of realized trips should be increased to form at least 5 percent of the total number of realized trips.

## References

- [1] Legac, I. et al. (2011), Gradske prometnice (Urban Roads), Faculty of Traffic and Transport Sciences, Zagreb, pp. 180-194, 2011.
- [2] Izrade prijedloga nacrtu pravilnika o regulaciji biciklističkog prometa i smjernica za projektiranje biciklističkih staza i traka (Making of the Proposal Draft about Regulation of Bicycle Traffic and Guidelines for Designing Bicycle Paths and Lanes), ISIP-MG d.o.o., 2011.
- [3] Biciklističke staze u Savskoj i Frankopanskoj ulici u Zagrebu (Bicycle Lanes in Savska and Frankopanska Streets), Trafficon d.o.o., 2011.
- [4] Projekt tehničkog rješenja uređenja inicijalne mreže biciklističkih staza za uspostavljanje biciklističkog servisa u gradu Zagrebu, (Project for Technical Solutions Regarding Arrangement of the Initial Network of Bicycle Lanes in the City of Zagreb), ARTERIJA d.o.o., 2010.
- [5] Planning more human city: Students attitudes towards cycling and transport in Zagreb, Naručitelj Grad Zagreb, Sveučilište u Zagrebu, Geografski fakultet i Institut društvenih znanosti Ivo Pilar, 2010.
- [6] Program uvođenja biciklističkog servisa u Gradu Zagrebu (Program for Introducing Bicycle Service in the City of Zagreb), ISIP-MG d.o.o. 2009.
- [7] Program regulacije i uređenja biciklističkog prometa Grada Zagreba, (Program of Regulation and Organization of Bicycle Traffic of the City of Zagreb), ISIP-MG d.o.o., 2008.
- [8] Prometna studija grada Zagreba, (Traffic Study of the City of Zagreb), MVA, 1999.
- [9] CROW, Record 25: Design Manual for Bicycle Traffic. CROW, The Netherlands, 2006.



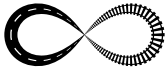

## MODEL FOR A SHORT – TERM FORECAST OF VEHICLES IN BITOLA TOWN

Vaska Atanasova, Lidija Markovik  
*Faculty of Technical Sciences, FYROM Macedonia*

### Abstract

The contemporary lifestyle leads to rapid increase of number of motorized traffic participants, thus there is a need for traffic planning, which requires forecasting. Considering the fact that contemporary software packages exist, based on modern technology and long - term experience it is decided to rely on the PTV Vision – VISUM software package, for traffic forecast in the Bitola town. A synthetic model was designed by this software package, modelling was done in accordance with the existing situation and model's calibration. This article presents the output results for the vehicle forecast in the town of Bitola, for next 5 years.

*Keywords: model, forecast, Bitola*

### 1 Introduction

Traffic planning is a specific process that determines the capacity needed to satisfy the transportation needs in the future of a pre-defined space. The traffic forecast will be described in this paper for the town of Bitola. Considering the fact that contemporary software packages exist, based on modern technology and long - term experience it is decided to rely on the PTV Vision – VISUM software package, for the traffic forecast in the town of Bitola. With this software package, modelling is done on the existing situation, model's calibration and forecast of vehicles in the Bitola town, for the next 5 years.

The first data collection is done for the purposes of traffic planning. A synthetic model has been designed by this software package where values gathered by counting the traffic at selected intersections in Bitola town were used as input data.

Model's calibration is done in VISUM, with Projection of routes, tool. Thus simultaneously, testing of results and comparison of numbered model sizes (dimensions) is done and a cooperative view will be presented.

Based on the created synthetic model, the resulting O-D matrix, corrections are made and predictions obtained for the flow sizes of thoroughfares in Bitola, for the next 5 years, individually for the flows of PC.

## 2 Data collection for traffic planning in Bitola

### 2.1 Zoning of the city of Bitola

Zones are areas with a particular land use and their location within the network (e.g. residential areas, commercial areas, shopping centres, schools). They are the origin and the destination of trips within the transport network.

Zoning is the process of determining and drawing the zones of a city.

Metropolitan municipality of Bitola was divided into 13 major areas that are functionally separate - compact enclosures that are mutually distinguished by certain city streets. On the other hand, they behave and act as a core - called the city of Bitola.

### 2.2 Cordon counting

On February 18<sup>th</sup> 2011 (Friday) from 2:00 pm to 3:00 pm, cordon counting of vehicles was made. The goal of the research is to provide an assessment of the accumulation of vehicles, and purpose of the survey is to give estimates on the number and structure of transit vehicles through the territory of Bitola.

A cordon implies notional boundary line around the city of Bitola, where counting of vehicles was carried out on all roads that intersect the cordon line.

The accumulation of vehicles on the cordon line is determined by summing the total number of vehicles entering and leaving the space in a given period. The results are given in Table 1.

**Table 1** Results of cordon counting

	Greece-Prilep	Greece-Ohrid	Ohrid-Prilep	Ohrid-Greece	Prilep-Ohrid	Prilep-Greece
Car	8	4	2	8	5	9
Bus	1	1	0	0	0	3
Track	1	0	1	0	1	2

### 2.3 Counting on intersections

Counting on selected intersection in Bitola was done on 29<sup>th</sup> October 2010 during the period from 7:00 am until 9:00 pm., 290 counters were included in two shifts.

Data from 38 intersections was analyzed, rush hour was determined and these values were used as input values in the model.

Values were written by the 'Turns' tool and then received with the help of software flow of links.

### 3 Transport demand modelling

Modelling is done on an existing situation, model's calibration and forecast on vehicles in Bitola and a synthetic model is designed with the PTV Vision-VISUM software package.

Fig. 1 represents nodes and links of the network in the area where research is done. Accordingly, each link was added to the section capacity and vehicles speed. Roads with the speed limit of 50 km/h are shown in red, roads with the speed limit of 40 km/h are in green and blue are roads with the speed limit of 30 km/h.

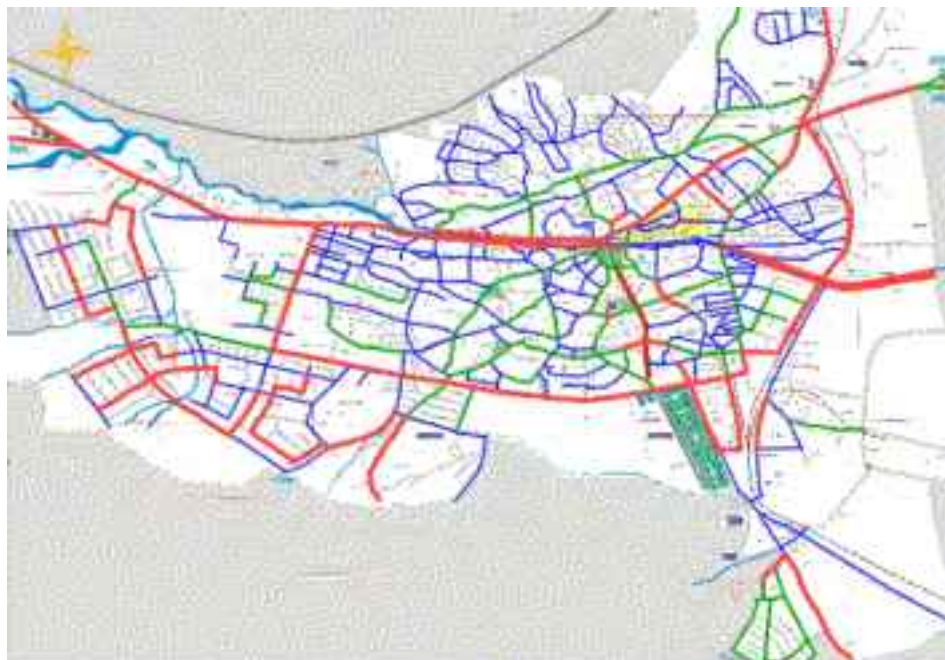

Figure 1 Graphic display of the road network with different speed limits

#### 3.1 Modelling on existing situation

##### 3.1.1 Zoning of the main zones

Metropolitan municipality of Bitola was divided into 13 major areas that are functionally separate - compact enclosures that are mutually distinguished by certain city streets. On the other hand, they behave and act as a core - called the city of Bitola.

For the purposes of the model further zoning was done. The main area includes different number of zones, so there are 46 zones. Fig. 2 presents the main zones (total 13) in blue, other zones (total 40) are in green and zones outside the city (total 6) are coloured red.

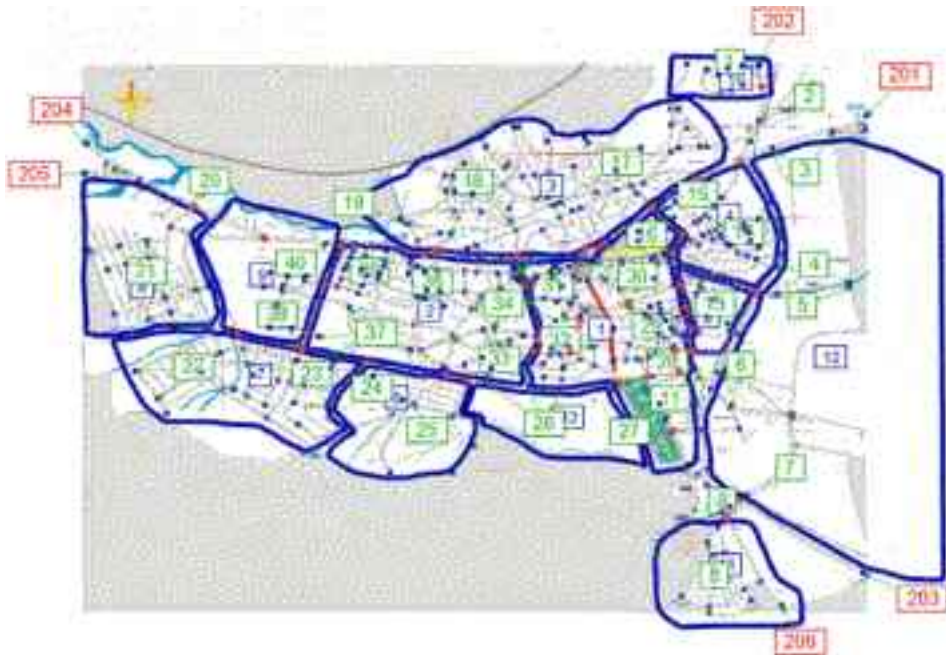

Figure 2 Separation of major areas into zones

### 3.2 Choosing a model forecast of transport demand

The formulation of the model depends on the initial sizes and input variables that will encompass. The basic definition is that the model should have the ability to 'reflect' the appearance that it simulates.

Modelling is done on an existing situation, models calibration and forecast of transport demand are done with the software package PTV Vision, VISUM.

#### 3.2.1 Model input values

As input sizes in the synthetic model, the values of the counting of traffic at selected intersections were used, marked in red and shown on Fig. 3. Also, the data from the cordon counting were used (cordon counting results are given in Section 2.2).

### 3.3 Model's calibration

Model's calibration is done in visum, with Projection of routes, tool. The goal of the calibration is bringing counting and modals sizes together. Thus simultaneously, testing of results and comparison of numbered model sizes (dimensions) is done.

Following, the comparative display of the counted values (green colour) and model's sizes (in red) for PC are below.

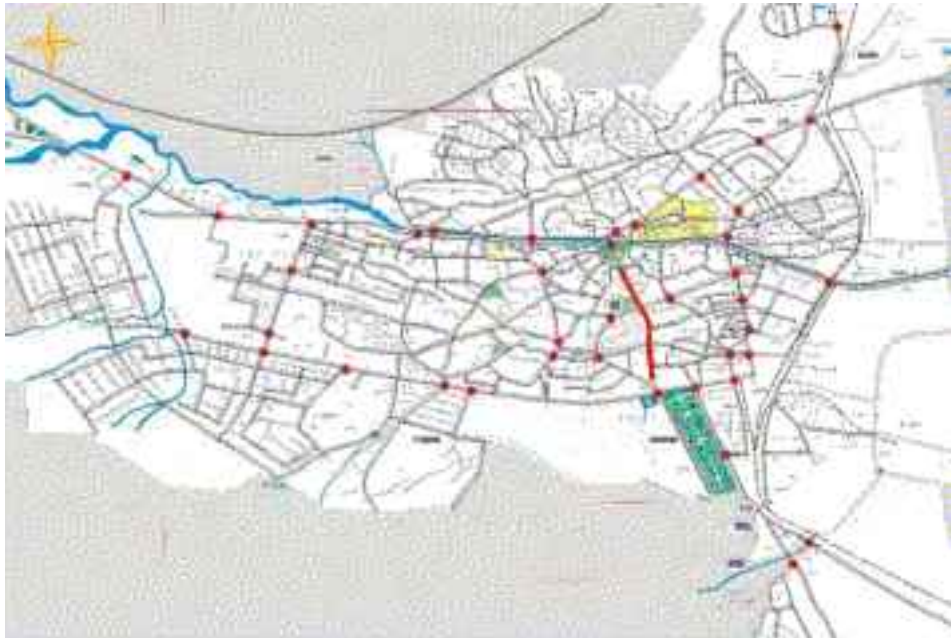

**Figure 3** Intersections counting in the area where the research was conducted

## 4 Transport demand forecast

### 4.1 Forecast for the existing situation

Forecast is a scientific prediction of some phenomena that are of great importance to human society. Based on the created synthetic model, the resulting O-D matrix, corrections are made as well as the forecast on vehicles in Bitola, for the next 5 years.

When conducting a forecast, an increase of 2% annually is taken into account, for the main zone 13 (Barracks in Bitola), i.e. the zones 26 and 27, taking into account the DUP (detailed urban plan) in this part of town. A balanced growth of 5% annually - for the first 2 years and 3% annually - for the next 3 years was presumed.

Illustrative, in particular sections would look like this: the section between the two junctions Partizanska - Ivo Lola Ribar and Partizanska – Kliment Ohridski, have 635 vehicles counted, while the model gives us the value of 666 vehicles. The projected forecast for 5 years, obtained 739 vehicles.

On Fig. 8 counted values are represented with green, and red are the obtained model sizes values.



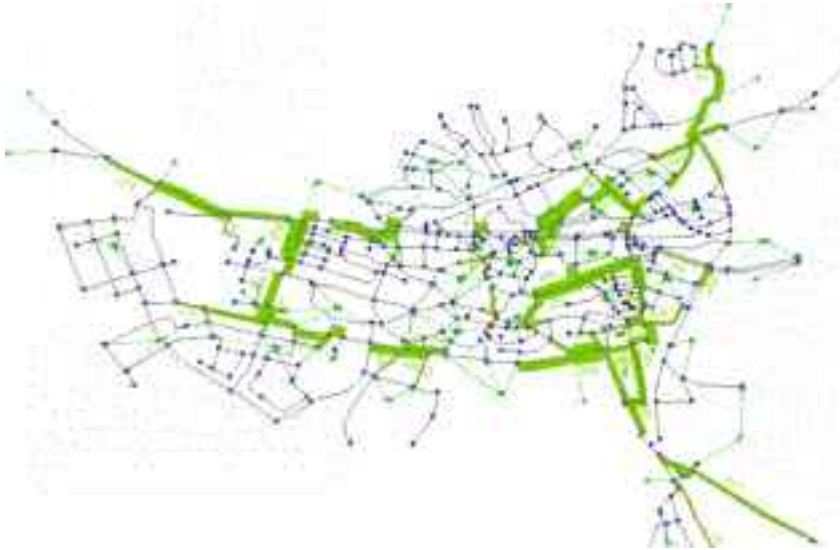

**Figure 4** Counted values for cars on intersections, calculated in Visum, and presented in sections

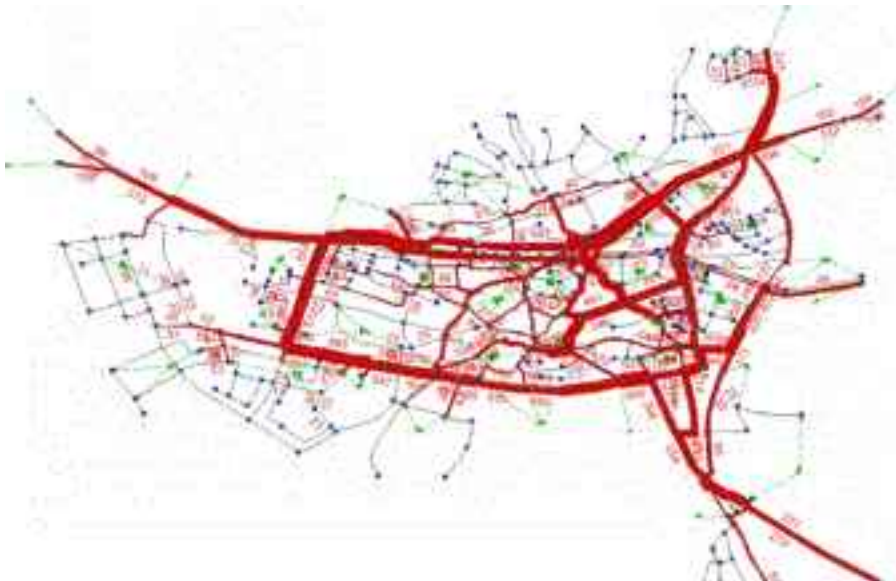

**Figure 5** Modal values for cars on the whole network - existing situation



Figure 6 Counted and modal values for cars - existing situation

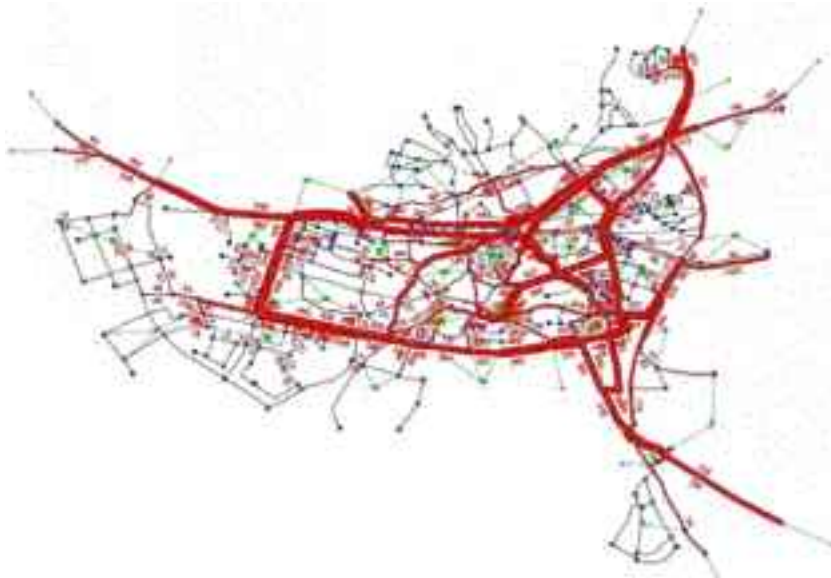

Figure 7 Forecast on vehicles in Bitola, for the next 5 years.



**Figure 8** An illustrated example for the section Partizanska–Ivo Lola Ribar and Partizanska–Vasko Karangelevski.

## 5 Conclusion

The forecast has always been a big challenge for scientist who conduct research in the field of future predictions as well as for others. Forecast is a prediction of some scientific phenomena that are of great importance to human society. Using the software package PTV Vision–VISUM we made a forecast on vehicles in Bitola, for the next 5 years, based on a lot of input data, we got an investigation outreach and data collection. We made comparative analyses of counted, modal and forecasted values. From the output results we can conclude that there is an acceptable deviation of modal values from counted values that mean suitability for modal's usage.

## References

- [1] Traffic study for Bitola town, Agreement number 08-1124/1, from 03.06.2010, during one year (June 1 2010 to June 2011).
- [2] General urban plan of the city of Bitola, 1 book, Institute of Urban Planning and Design, LLC, Bitola, Bitola, 1999.
- [3] Vaska Atanasova, Ph. D., M.S.E., BA. soob. Eng. "Traffic Planning", internal lectures, University "Ss. Kliment Ohridski ", Faculty of Technical Sciences, Bitola, 2010.
- [4] Towards sustainable urban transport policies, Recommendation for local authorities, SMILE project, European Commission, 2004.
- [5] PTV America, visum User Manual, Version 7.50. 2. MODEL DESCRIPTION. 2.1. Network Model. 2-3. 2.1.1. Transport systems, April 2001.
- [6] White Paper 2011, Roadmap to a Single European Transport Area – Towards a competitive and resource efficient transport system, European Comission, - COM/2011/0144 final/ Brussels, 28.03.2011

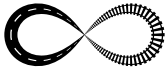

## E–MOBILITY IN URBAN AREAS AND THE IMPACT OF PARKING ORGANISATION

Harald Frey<sup>1</sup>, Anna Mayerthaler<sup>2</sup>, Paul Pfaffenbichler<sup>1</sup>, Tadej Brezina<sup>1</sup>

*1 Research Center of Transport Planning and Traffic Engineering, Institute of Transportation, Vienna University of Technology, Austria*

*2 Wiener Stadtwerke Beteiligungsmanagement GmbH  
(Vienna Public services provider), Austria*

### Abstract

In this paper we explore the preconditions and requirements to enable the renewal of the vehicle fleet towards e–cars without weakening eco–mobility (public transport, cycling, walking). We follow a combined approach of arranging charging infrastructure and parking space regulations. We analyze the results of this approach by modelling different scenarios for the case study city of Vienna with the LUT<sub>I</sub> (land–use transport interaction) model MARS (Metropolitan Activity Relocation Simulator). Four different policy scenarios are modelled and the results presented. We look at changes in transport behaviour (modal split and vehicle kilometres), the emissions and the impact on public transport ridership.

*Keywords: e–mobility, parking organisation, modal split,  
dynamic modelling, human behaviour*

### 1 Introduction

E–mobility is currently facing a promising boom, which readjusts both the requirements and possibilities of organizing a future transport system. The chances of individual e–mobility to reach certain transport policy goals are obvious – minor dependency on fossil fuels and the reduction of greenhouse gases and air pollutants. However, lower user–specific operational expenses, exclusion of certain classes of vehicles from environment–based cordons (e.g. low–emission–zones) and the omission of 'environmental reasoning' for certain user groups can lead to counterproductive system effects and a net–growth of private motorized transport (PMT). Various urban administration authorities have set themselves objectives such as the strengthening of public and non–motorized transport.

We show what kind of organizational structures are necessary for enabling the renewal of the vehicle fleet towards e–cars without weakening public transport (PT), cyclists and pedestrians. We describe and present four different scenarios which were influenced by different transport policies.

### 2 Method

The analysis was carried out with three models. Two models (SERAPIS) served for calculating the fleet composition for conventional & hybrid (in the following named as cars) and electric vehicles (e–cars) for the city of Vienna and its hinterland.

SERAPIS (Simulating the Emergence of Relevant Alternative Propulsion technologies in the car and motorcycle fleet Including energy Supply) is a dynamic model that simulates fleet

developments and the shares of different propulsion technologies. Hence the demand for the electricity economy and the potentials for reducing CO<sub>2</sub> emissions are derived. With the land–use transport model MARS the traffic behaviour in the model region was simulated. The MARS (Metropolitan Activity Relocation Simulator) model was developed at Vienna University of Technology’s Research Center of Transport Planning and Traffic Engineering [1]. It is a land–use transport interaction model which simulates the mutual interactions between the land–use and the transport system [2–4]. The model zones from the model described in this paper cover the 23 Viennese districts and the Vienna hinterland. The MARS model was connected to SERAPIS via two variables: the operating costs, calculated in MARS, served as input variable for the SERAPIS models; and the fleet development as an output of SERAPIS served as input for MARS.

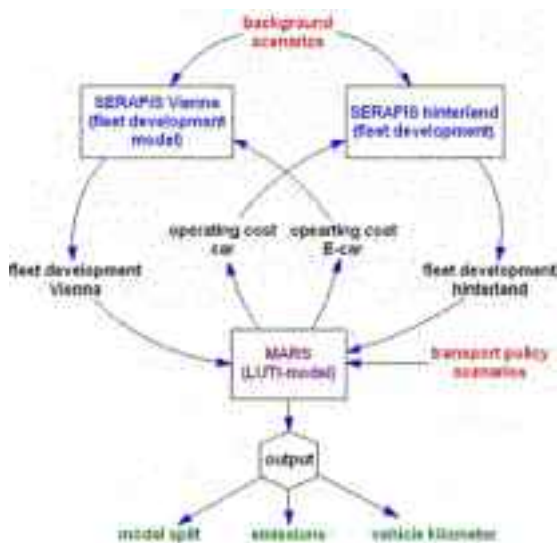

Figure 1 Links of the three models and external input.

The data basis covers demographical data for the case study area, transport relevant data (level of motorization, modal split, etc.) and transport policy goals.

### 3 Scenario overview

Besides the extrapolation existing trends of relevant traffic indicators (Business as usual – BAU), we designed three different transport policy scenarios (E–car, Equidistance, Equidistance + E–car). The background scenarios cover the development of crude oil price and subsidies for e–cars as well as different fleet developments for e–cars which are the basis for each scenario. We combined the transport policy scenarios with different background scenarios in order to define and model four policy runs.

Table 1 shows the assumptions for our four scenarios (subsidies for e–cars, transport policies).

Table 1 Scenario setting in Vienna.

Scenario			BAU	E-car	Equidistance	Equidistance + E-car
Sub-sidies	Funding for e-cars	low	X		X	
		high		X		X
Transport policies	Density of charging stations	low	X		X	X
		high		X		
	Availability of public parking spaces	low			X	X
		high	X	X		
	Parking fees for e-cars	yes	X		X	X
		no			X	
	Fuel duty	low	X	X		
		high			X	X

### 3.1 Background scenarios

In this paper we assume a progressive increase of the crude oil price until the year 2030. Compared to the base year 2010 the price will double. Our assumed crude oil price development was compared with several studies [5–10] and projects and for two scenarios (BAU, E-Car) the fuel duties equal Austria's 2010 levels (0.43 EUR/litre for petrol, 0.30 EUR/litre for diesel) and remain constant. In both equidistance scenarios the fuel duty increases constantly over time up to +30 % in the year 2030 (0.59 EUR/litre for petrol, 0.41 EUR/litre for diesel). We distinguished between the subsidy levels for e-cars of the E-car and Equidistance scenarios. In the E-car scenario the subsidies increase rapidly in the first year to 5,000 EUR/vehicle and then decrease until the year 2021. Further we distinguish between the development of the gross and net purchase prices of e-cars. The net purchase price disregards differences in sales tax, engine related insurance tax and standard fuel consumption tax.

## 4 Transport policies

We modelled four different transport policy scenarios varying in the following parameters:

- a Spatial arrangement of the charging infrastructure and parking places for e-cars.
- b Walking time from trip origin to the charging stations, respectively the parking place.
- c Parking fees (level and location).
- d Fuel duty for diesel and gasoline cars. E-cars were excluded.

Each scenario was calculated separately for e-cars and cars for the case study area of Vienna and its hinterland.

### 4.1 BAU scenario

The BAU scenario extrapolates the current development. No massive infrastructure changes are considered. The charging infrastructure for e-cars in Vienna is organized in collective parking garages provided with a low density (<5 %). In this scenario charging infrastructure is not provided in public streets. In comparison to conventional cars the walking time to charging & parking places for e-cars is therefore very high (~5 min.). Both, e-cars and conventional cars need to pay inner city district parking fees. In the urban hinterland the private car is easily accessible. The scenario is based on the fact that in the surroundings of Vienna people can park and charge their car nearby their house or their apartment. The access time is short (about 0.5 minutes). A lot of detached houses have their private parking place (minimal walking time to the car) and most of the communities have no parking fee.

## 4.2 E-car scenario

The E-car scenario is based on a strong increase in the density of charging infrastructure in public spaces in Vienna (>30 %). Therefore the walking time from trip origin to the charging infrastructure alternatively to the parking place for e-cars is equal to the access time for cars (~1 min.). Parking for e-cars is free (the parking fees in parking garages are reduced) and no taxes similar to the fuel tax are levied. The parameters for the Vienna hinterland remain similar to the BAU scenario.

## 4.3 Equidistance scenarios

### 4.3.1 Principle of equidistance

Pedestrians in their walking behaviour follow a certain function of attractiveness [11]. Short walks offer 100 % attractiveness – longer walks far less. Pedestrians assess time subjectively and therefore value their walks considering their surrounding areas.

Walther [12] found that the access walks of pedestrians to PT stops and the access and egress times to parking places play an important role in transport mode choice. Humans do not perceive access and egress time linearly but exponentially. With increasing walking distance the perception thereof increases disproportionately. If it is possible to park a car in the basement parking garage of one's house, or in the public space directly in front of one's home or work place, the car presents a 100 % attractive accessibility. A PT stop 400 meters away holds less than 20 % of attractiveness in inner city surroundings. Thus people are going to prefer their car over the bus, if somehow possible.

To create equal opportunity conditions between PMT and PT, equidistance between parked cars and adjacent PT stops for all activities needs to be introduced.

Cars and other PMT need to be parked in centrally organized parking garages distributed over the city, resulting in at least a distance equal to the distance of frequently operating PT stops.

### 4.3.2 Equidistance scenario

In the Equidistance scenario the charging and parking for e-cars and parking cars are organized in collective parking garages. The charging infrastructure for e-cars is provided in collective parking garages (>5 %). Thereby the access time (walking) is increased for conventional cars to 3 minutes in the city equal to e-cars in this scenario.

Parking space management is in action area-wide in Vienna. Parking fees for cars are increased until the year 2020, they have to be paid city-wide and are compulsory for e-cars too. The fuel duty is increasing over time until the year 2030 (+30 % of the base value), but is not assigned to e-cars. A similar energy consumption tax for e-cars is not implemented. The conditions for the hinterland do not change in reference to the previous scenarios.

### 4.3.3 Equidistance + E-car scenario

There are two major differences between the Equidistance and the Equidistance + E-car scenario:

- 1 The increased number of e-cars in the fleet due to higher subsidies.
- 2 The organizational form of parking space and charging is equal (collective parking garages) but more garages are equipped with charging facilities in this scenario (>30 %).

The other settings remain the same.

## 5 Evaluation of the results

The scenarios were modelled under consideration of the transport policy goals of the city of Vienna for the year 2020. The Vienna transport master plan defines the following modal split objectives for Vienna in the year 2020:

- Reduction of PMT trips to 25 % of all trips.
- Increase in bicycle share to 10 %.
- Increase in PT share from 34 % to 40 %.
- For commuting flows from the Vienna hinterland the distribution between public transport and PMT should shift from 35 % / 65 % to 45 % / 55 %.

## 6 Results

We analyzed the results of the scenarios concerning the changes in transport behaviour by looking at the changes in modal split.

### 6.1 Changes in transport behaviour

The scenario E-car shows no relevant change in transport behaviour compared to the BAU scenario. Some car users switch to e-cars, but the share of eco-mobility modes remains constant. The sole increase in funding of e-cars without changing the organizational structures for parking does not change the modal split very much (see Figure. 2).

The scenarios Equidistance and Equidistance + E-car show crucial changes. Figure 2 and 3 depict the modal split for the year 2020 for Vienna citizens and in-commuters to Vienna. The combination of equidistance with an increased funding of e-cars is the most effective way of changing transport behaviour.

The modelled measures in these two scenarios also enable the achievement of Viennese transport politics objectives. Basically shifts from car to public transport occur.

The picture looks different for the in-commuters. Many people living in Vienna's hinterland have the possibility to park their car or e-car close to their home respectively on private ground. Due to the policy that only destination locations in Vienna include a charged parking organization the modal split changes are modest (see Figure 3).

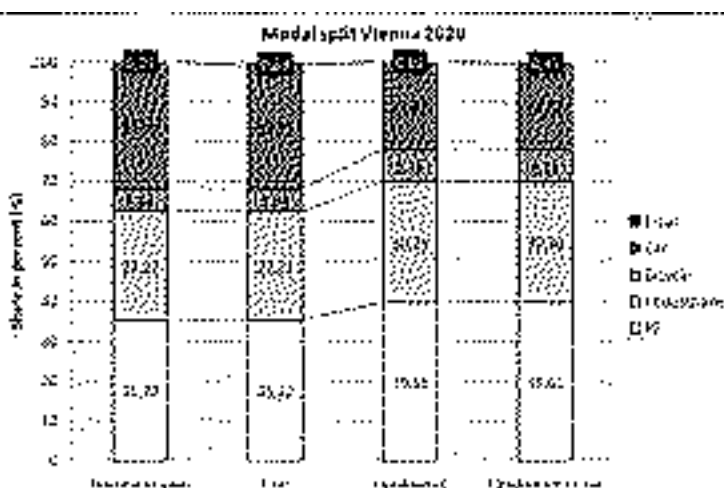

Figure 2 Modal split Vienna 2020 – comparison of the scenarios.



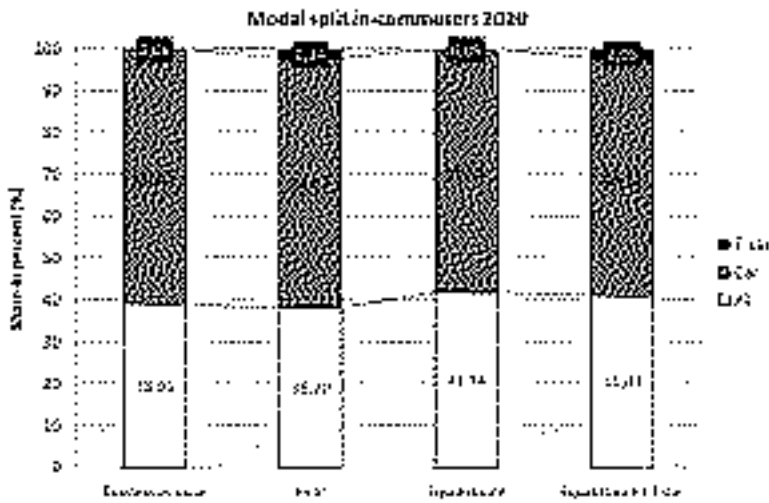

Figure 3 Modal split in-commuters 2020 – comparison of all scenarios.

## 6.2 Emissions

Table 2 shows the reduction of vehicle kilometres, NO<sub>x</sub> and CO<sub>2</sub> emissions in the year 2020 compared to the BAU scenario. It's clearly visible that the most effective emission reduction scenario is the Equidistance + E-Car. More than half of Vienna's primary emissions can be reduced in this scenario.

Table 2 Vehicle kilometres, NO<sub>x</sub> and CO<sub>2</sub> emissions in the year 2020 compared to the BAU scenario.

Reduction of vehicle-km, NO <sub>x</sub> and CO <sub>2</sub> emissions in the year 2020 in relation to the BAU scenario [%]			
Parameter	E-car	Equidistance	Equidistance + E-car
Veh-km Vienna	-2.1	-29.3	-30.4
Veh-km in-commuters	-1.7	-6.6	-8.2
NO <sub>x</sub> Vienna	-16.4	-31.2	-41.6
NO <sub>x</sub> in-commuters	-15.9	-8.1	-22.0
CO <sub>2</sub> (total)	-3.8	-14.9	-17.9

## 6.3 Impact on ridership in public transport

Whereas the ridership in public transport increases in the Equidistance scenario in Vienna as well as in its hinterland the percentage decreases in the hinterland in the scenario Equidistance + E-car. The massive one-way advancement of e-cars (near parking places and charging stations) has negative effects on the transport policy goals and takes effect especially in the car-oriented suburban areas of the city. The promotion of PMT and its infrastructure decreases the ridership of PT. In the city of Vienna these negative effects can be diminished because of the parking organization based on the principle of equidistance.

**Table 3** Ridership in PT changes for the 3 policy scenarios.

Increase/Decrease of ridership in public transport [%]			
Region	E-car	Equidistance	Equidistance + E-car
Vienna	-0.2	2.0	2.0
Hinterland	-4.4	1.2	-2.5
Total	-1.5	1.7	0.5

## 7 Conclusions

We show in this paper that the one-way promotion of e-cars contradicts the transport policy goals of the city of Vienna. The results can be applied to other cities which plan to organize traffic in a more efficient and sustainable way. One of the key measures to strengthen the modal split of non-motorized traffic and public transport lies in the parking organization. As soon as car drivers have to park their cars in collective parking garages a more equitable choice of means of transport is possible. The principle of equidistance and collective garages fits perfectly into the requirements for a liveable city structure. E-cars are able to support these needs as far as the charging infrastructure is allocated in central parking garages and not in public space. Structures which permit short access and egress times to the car, promote PMT. Some negative effects of fossil fuel powered cars, like carbon dioxide emissions, can be reduced by e-cars.

The problems of congestion, use of space, energy consumption and accidents cannot be solved by e-cars. In order to benefit from e-cars without counterproductive effects, an implementation of charging infrastructure under consideration of the principle of equidistance is necessary.

## References

- [1] Pfaffenbichler, P., The strategic, dynamic and integrated urban land use and transport model MARS (Metropolitan Activity Relocation Simulator), in Institute for Traffic Planning and Traffic Engineering. 2003, University of Technology: Vienna.
- [2] Pfaffenbichler, P. and G. Emberger, Die Bewertung der Nachhaltigkeit innovativer städtebaulicher Maßnahmen mit dem Simulationsmodell MARS, in CORP 2004. 2004: Vienna.
- [3] Pfaffenbichler, P. and S. Shepherd, A Dynamic Model to Appraise Strategic Land-Use and Transport Policies. *European Journal of Transport and Infrastructure Research*, 2003. 2003(2/3): p. 255–283.
- [4] Mayerthaler, A., R. Haller, and G. Emberger. A Land-Use/Transport interaction model for Austria. in *The 27th International Conference of the System Dynamics Society*. 2009. Albuquerque/USA.
- [5] Renner, S., Baumann, M., Jamek, A., Lang, B., and Pfaffenbichler, P. (2010). 'Visionen 2050 - Identifikation von existierenden und möglichen zukünftigen Treibern des Stromverbrauchs und von strukturellen Veränderungen bei der Stromnachfrage in Österreich bis 2050.' Österreichische Energieagentur im Auftrag von Österreichs Energie (VEÖ), Wien.
- [6] Haas, R., Kloess, M., Könighofer, K., Canella, L., Jungmeier, G., Prenninger, P., and Weichbold, A. (2009). 'Entwicklung von Szenarien der Verbreitung von PKW mit teil- und voll-elektrifiziertem Antriebsstrang unter verschiedenen politischen Rahmenbedingungen - vorläufiger Endbericht Projekt ELEKTRA.' Technische Universität Wien, Institut für Elektrische Anlagen und Energiewirtschaft, Wien. [http://verkehrstechnologien.at/Out/lib\\_binfile/get\\_attachment?attachmentid=112](http://verkehrstechnologien.at/Out/lib_binfile/get_attachment?attachmentid=112).
- [7] Monzon, A., and Nuijten, A. (2006). *STEPS - Transport Strategies under the Scarcity of Oil Supply*, Buck Consultants International, The Hague.

- [8] OECD/IEA. (2009). World Energy Outlook 2009, Organisation for Economic Co-operation and Development, International Energy Agency, Paris.
- [9] US EIA. (2009). 'Annual Energy Outlook 2010.' U.S. Energy Information Administration. [www.eia.doe.gov/oiaf/aeo/index.html](http://www.eia.doe.gov/oiaf/aeo/index.html).
- [10] Prognos. (2009). 'Trendstudie Energiemarkt 2020 mit Ausblick auf 2030. Energie in privaten Haushalten.' Bundesverbandes der Energie- und Wasserwirtschaft e.V. (BDEW), Berlin, Mai 2009.
- [11] Knoflacher, H. Human Energy Expenditure in Different Modes: Implications for Town Planning. in International Symposium on Surface Transportation System Performance. 1981: U.S. Department of Transportation.
- [12] Walther, K., Nachfrageorientierte Bewertung der Streckenführung im öffentlichen Personennahverkehr. 1973, Rheinisch-Westfälische Technische Hochschule: Aachen.

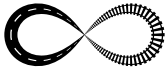

## DEMOGRAPHIC MODEL 'AGE-COHORT' FOR MODELLING OF URBAN MOBILITY IN LONG TERM

Zoran Krakutovski

*University St. Cyril and Methodius, Faculty of Civil Engineering Skopje,  
Republic of Macedonia*

### Abstract

The forecast of urban mobility in the long term is one of the great challenges of planning of the urban transport. The classical model for traffic demand forecast is represented by one algorithm based of following four steps: trip generation, trip distribution, mode choice and route assignment. The contestation of traditional method, based of statistical data collected on one period, shall be improved by usage of demographic model. The demographic model is pertinent for estimation of trip generation. The use of the demographic approach with data from repetitive surveys makes it possible to get insight in the behaviour dynamics of individuals belonging to the several generations at various stages of their life cycle. The decomposition of temporal effects into an effect of age and an effect of generation (cohort) makes it possible to draw the sample profile during the life cycle and to estimate its temporal deformations. It is the fundamental concept of the 'age-cohort' model which has been developed in INRETS-DEST (France – from January 2011, the INREST-DEST is a part of The Institute of Science and Technology for Transport, Development and Networks – IFSTTAR: [www.ifsttar.fr](http://www.ifsttar.fr)), basically for projection of car household ownerships, and after it is adapted for forecast of mobility on long term. The comparison of forecasts between the 'age-cohort' model and the growth factors method shows the relevance of the demographic model. Sensitivity tests of the model, as well as the capacity of the model to carry out simulations are also justified. The application of the model relates to the agglomeration of Lille (France), where we have three data surveys at approximately 10 years intervals.

*Keywords: urban mobility, age, cohort, transport planning, mobility forecast model.*

### 1 Introduction

The demographic model in its basic form describes the change in number and structure of a human population in a particular territory. Demographic changes are characterized by great inertia of change and this is a reason why the projections are generally based on extrapolation of past trends. To apply the model in the projections of daily mobility, it should separate projections of the population on the one hand, and projections of mobility on the other. Thus, the general structure of a population model contains two main parts (Gallez, 1994):

- the first part includes projections of population based on purely demographic phenomena like fertility, mortality and migration of the population. Thus, we obtain estimations containing the number of individuals (or households) according to age, sex and area of residence;
- the second part is principal for modeling of mobility and includes estimates of a standard profile-type during the life cycle. The basic idea is to trace the evolution curve of the endogenous variable of mobility (for example, the number of trips per day, distances ...) according to age of individuals and to quantify the deformation of this standard profile-type

caused by the effects of generation and time. The modeling is done through a model Age–Period–Cohort (APC), or a model Age–Cohort (AC). The first part of this model is the subject of demographic study and the second part is the subject of our interests with the objective of achieving the projection of mobility on long–term.

## 2 Data used in the analysis

### 2.1 Cross–sectional standardized surveys

The main sources of mobility analysis are cross–sectional surveys designed to identify the principal determinants of mobility at a given date. The indicator normally used to measure daily mobility is the number of trips a person makes each day.

These surveys are standardized, but they contain large heterogeneities on the age of individuals and generations to which these individuals are associated. In this paper we show how cross–sectional surveys repeated at regular intervals can be used to construct a longitudinal data essential for analysis and projections of daily mobility.

Using personal mobility surveys conducted in Lille (French urban agglomeration), we can reconstitute the mobility of several generations (cohorts) of Lille residents, and project daily mobility up to 2030 with a model distinguishing age and cohort effects.

Mobility data shall be collected using specific techniques to ensure optimum reliability. These techniques can be classed in two broad families (Orfeuil, 2000):

- Counts made in public transport facilities or road traffic counts to record the number of travellers or vehicles at one point in the network
- Household surveys to estimate the main mobility indicators with reference to several factors (CERTU – Centre for studies on urban planning, transportation and public facilities, France – standard).

The data used in this paper come from CERTU standard household travel surveys conducted in 1976, 1987 and 1998 in Lille. Sample size is large enough to distinguish three zones of residence and to disaggregate the population for analysis by age groups and gender.

**Table 1** Samples used for the analyses – Lille agglomeration

Questionnaire type	Number of responses by survey		
	1976	1987	1998
Households	9804	3465	3744
Individuals (age>5years)	27005	8345	8454
Internal trips	76383	29967	33907
Total trips	79948	31969	35804

\*Internal trips are those whose origin and destination are inside the 1976 survey limits Sources: INRETS, Household travel surveys 1976, 1987 and 1998

### 2.2 Creation of a longitudinal data

The analysis and long–term projections of urban mobility, based on temporary effects of age, cohort and period, need use of longitudinal data. The ideal basis for longitudinal data analysis is a panel of individuals observed over a long period. However, the main statistical sources on daily mobility are cross–sectional surveys designed to identify its determinants on a given date. These surveys are not panels, but they can be used to construct a 'pseudo panel'.

The cross–sectional data have the potential to identify individuals from the same cohort, named the cohort of birth. Between the observation period (p), age of individual (a) and birth of cohort (c) exist the following relationship:

$$c = p - a \quad (1)$$

Using this technique, we can create longitudinal data (pseudo-panel), which enables to follow the dynamic of behaviour (Deaton, 1997; Godwin and Layzell, 1985). According to these three surveys we can make a following longitudinal data sample (table 2).

This longitudinal data is sufficient to create cohort by gender and precede the analysis and projections of mobility through demographic variables. Therefore, the pseudo-cohorts are formed using the date of birth and the individual characteristics which are not subject to variation during life cycle as a gender.

### 3 Analysis of mobility according to cross-sectional surveys and pseudo-panel data

The mobility in the study area is measured along three specific variables:

- The average number of trips per person aged 5 or over made by city-dwellers in a normal weekday for any purpose and using any form of transport.
- The average distance travelled daily (named 'distance budget') calculated over 26 zones in urban agglomeration,
- The average time spent on daily trips, called the 'time budget'.

The mobility in the Lille agglomeration grew rapidly over the period 1976–1998, particularly among women population.

**Table 2** Longitudinal data sample sizes – Lille agglomeration

Birth year (cohort)	1976 survey		1987 survey		1998 survey	
	Age of cohort in 1976	Cohort size	Age of cohort in 1987	Cohort size	Age of cohort in 1998	Cohort size
Pre 1895	82 &+	444				
1895–1905	71–81	1807	82 &+	159		
1906–1916	60–70	2603	71–81	519	82 &+	150
1917–1927	49–59	3485	60–70	832	71–81	526
1928–1938	38–48	3842	49–59	1039	60–70	793
1939–1949	27–37	4032	38–48	1111	49–59	958
1950–1960	16–26	5403	27–37	1520	38–48	1418
1961–1971	5–15	5389	16–26	1661	27–37	1350
1972–1982			5–15	1504	16–26	1835
1983–1993					5–15	1424
<b>Total</b>		<b>27005</b>		<b>8345</b>		<b>8454</b>

Sources: Calculation based on household travel surveys in Lille

**Table 3** Evolution of mobility in the Lille agglomeration – internal trips\*

Year	Number of trips/per.			Distance budget (km/per./day)			Time budget (min./per./day)		
	Men	Wom.	Total	Men	Wom.	Total	Men	Wom.	Total
1976	3,02	2,66	2,94	7,1	4,2	5,6	49,1	40,2	44,4
1987	3,74	3,47	3,54	8,5	6,3	7,4	52,9	46,1	49,4
1998	4,05	3,97	4,07	9,9	7,8	8,8	56,9	53,5	55,1

\*Internal trips are those whose origin and destination are inside the 1976 survey limits Sources: INRETS, Household travel surveys 1976, 1987 and 1998

The greater use of private car affects growth of the daily mobility. The existence of urban infrastructure and access to modes of transport also affect mobility behavior. The trips realized by walking and by public transport are more frequent in centre than in the suburbs where the car is dominant mode of transport.

The age dependent variations in mobility obtained by each cohort according to the longitudinal data are different from those obtained through cross-sectional observation (figure 1).

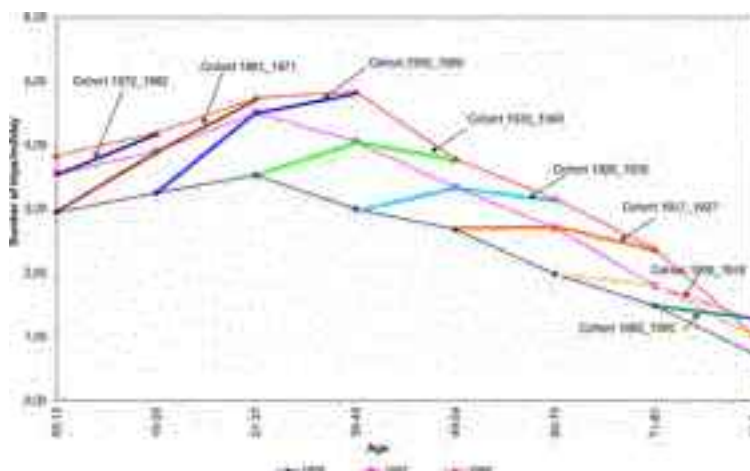

**Figure 1** Cross-sectional and longitudinal view of mobility by age and cohorts – number of trips/individual/day

The figure 1 clearly illustrate the difference between a cross-sectional view of mobility by age (a curve for each of the three survey dates) and a curve showing the variation in mobility by age (the curves for each cohort). The divergences between the curves of the different cohorts at any given age can be interpreted as the cohort effects.

#### 4 Notion of the model 'age-cohort' (AC)

The effects of time in the analysis can be introduced along the three dimensions of age, cohort and period. Nevertheless, the pure effects of each component are impossible identify separately. We assume here that there are no period effects, since these can be ignored when dealing with short-term instabilities. Besides, the number of surveys used in this study is too small to correctly identify period effects. This is the raison to use the model AC specification that captures the influence on behaviour of the 'age' and 'cohort' factors only. The standard profile-type of mobility during the life cycle can be reconstructed for a reference cohort (figure 2).

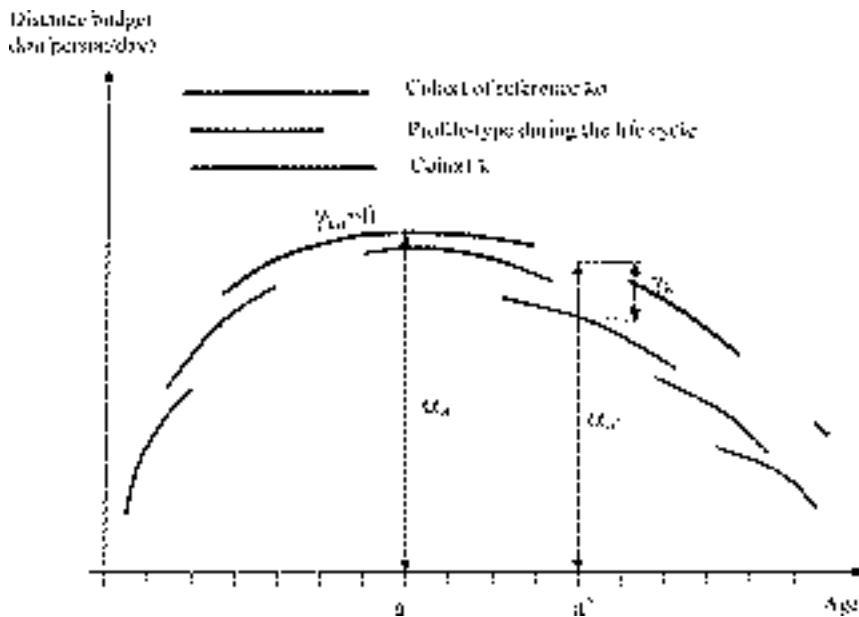

Figure 2 Theoretical basis for estimating 'age-cohort' model

The cohort effects are showed by the difference between each cohort's trajectory and the curve of the standard profile-type for the reference cohort  $k_0$ . For an additive AC model we make the assumption of parallel trajectories for successive cohorts. The effects for a cohort  $k$  are thus given by the divergence between its life-cycle curve and the standard profile-type for the reference cohort  $k_0$  which is equal in distance to the relative difference  $\gamma_k$ . The mathematical expression of the model is follows:

$$M_{a,k} = \alpha_{a(k_0)} \cdot A_a + \gamma_k \cdot C_k \cdot \varepsilon_{a,k} \quad (2)$$

where:

- $M_{a,k}$  is the measure of observed mobility at age  $a$ , for the individuals of cohort  $k$ ,
- $\alpha_{a(k_0)}$  is the measure of estimated mobility at age  $a$  for an individual of the reference cohort  $k_0$ ; this defines the 'standard profile-type' over the life cycle,
- $\gamma_k$  is the difference in the trajectory of cohort  $k$  relative to the curve for the reference cohort  $k_0$  ( $\gamma_0=0$  for the reference cohort  $k_0$ ),
- $A_a$  and  $C_k$  are indicator variables for age and cohort,
- $\varepsilon_{a,k}$  is the error term for the model.

## 5 Projections of mobility on long-term

The application of the model AC needs to separate population projections from the mobility projections. The population projections are based on fertility, mortality and migration assumptions. They can be made according to age and sex of individual by zone of residence. The projections of mobility up to year 2030 in the Lille agglomeration are made using this AC model following the methodology presented earlier (Armoogum and Madre, 1997; Armoogum et al., 2002).

The model AC is use first to project the proportion of persons living in no-car households, single-car households, and multiple-car households, then we make mobility projections for each population category.



The projections for the number of trips per day per person within the study area yield a growth rate of 20% until 2030, which indicates a slowdown in the increase observed in the period 1976–1998 (about 42% increasing).

The projections of time budget indicate small growth of around 6,5% between 1998 and 2030, which is also slower relative to the period 1976–1998. The estimations show that the time budget will approach a value of 59 minutes.

The model also indicates a 24% growth in budget distance between 1998 and 2030, which is lower than the rate of growth observed in the past (57% between 1976 and 1998).

The projections based on the rates of growth are also made. The growth rates are calculated according to three surveys, and they can be compared with the projections produced by the AC model.

## 6 Conclusions

The results estimated with the AC model are not as high as those obtained with the growth rate method. Comparison of the projections shows large differences between the results from AC model and those obtained with the growth rates. The trend extrapolation approach does not take into consideration the behaviour specific to each cohort and the projected values are higher than the model estimates. The demographic models appear to be much better than classic modelling approaches based on growth rates, since they capture more fully the tendency to saturation observed in a part of population.

The age-cohort model reaches its limits when modelling is geared towards evaluation of transport policy scenarios. Because economic variables such as incomes and prices are not taken into account, their respective roles in the changes cannot be estimated. Nevertheless, the long-term projection of economic factors also presents some difficulties related to discontinuities. In reality, the age and cohort effects encompass several dimensions that are not explicitly defined by one variable, but are embedded in individual habits and behaviour. The introduction of individual speed into the model makes it possible to constitute several scenarios for evolution of total daily distance and to consider several actions in transport planning.

## References

- [1] Gallez Caroline, *Modèles de projection à long terme de la structure du parc et du marché de l'automobile*, thèse de l'Université de Paris I, 353 p, 1994.
- [2] Deaton A., *The analysis of Household Survey: A Microeconomic Approach to Development Policy*, Baltimore, Johns Hopkins University Press for the World Bank, 479 p, 1997.
- [3] Goodwin P.B., Layzell A.D., 'Longitudinal analysis for public transport policy issues' in Jansen G.R.M., Nijkamp P., Ruijgrok C.J. (eds.), *Transportation and Mobility in an Era of Transition*, Amsterdam, Elsevier, p.p.185-198, 1985.
- [4] Orfeuil J.-P., *L'évolution de la mobilité quotidienne, comprendre les dynamiques, éclairer les controverses*, Les synthèses de l'INRETS, 37, 146 p., 2000.
- [5] Armoogum J., Madre J.-L., Buissière Y., *Uncertainty in Long Terme Forecasting of Travel Demand from Demographic Modelling*, The 13-th Mini-Euro Conference: Handling Uncertainty in Transportation Analysis, 10-13 June, Bari, Italy, 2002.
- [6] Armoogum J., Madre J.-L., *Accuracy of data and Memory Effects in Home-based Surveys on Travel Behaviour*, Washington, Transport Research Board, 1997.

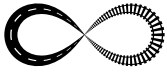

## APPROACH TO DEALING WITH THE TRANSPORT DEMAND MANAGEMENT IN CITIES WITH THE REVIEW ON CITY OF ZAGREB

Marko Slavulj, Davor Brčić, Ljupko Šimunović

*University of Zagreb, Faculty of Transport and Traffic Sciences, Croatia*

### Abstract

All over the World, cities register an increasing population growth, the economy and the number of vehicles, which affects the number of trips and transport network congestion. The effects of the congestion reduction strategies are highly variable and related to a specific area. Certain strategies can be highly effective in one situation, but also completely ineffective in another. When considering the congestion reduction strategies it's important to take into account generated traffic. Generated traffic does not eliminate the benefits of capacity expansion projects, but it can significantly change the nature of their benefits. It often means that congestion reduction benefits are smaller and shorter lived than projected, that more benefits consist of increased consumer mobility and urban fringe property values, and induced vehicle travel can exacerbate problems such as downstream congestion, crashes, pollution emissions, urban sprawl and overall automobile dependency. Estimation that ignores the effects of generated traffic tends to overstate the true benefits of roadway capacity expansion and understate the benefits of demand management strategies. Current transportation planning practices tend to favour roadway capacity expansion over demand management solutions to traffic congestion problems. These practices should be changed for Transport Demand Management (TDM) strategies to be implemented when it is the most cost effective solution overall. This paper analyzes the definitions, purpose and goals of TDM. Also, a classification of TDM measures was done and a combined approach of planning measures explained. TDM measures considering the location can be applied to the new built areas, existing work sites, other trip generators and the regional (subregional) areas. At the end, situation in the transport system and the applicability of TDM measures in the City of Zagreb will be commented.

*Keywords: traffic planning, congestion reduction strategies,  
Transport Demand Management, CIVITAS, Zagreb*

### 1 Introduction

Transportation demand management (TDM) measures came into being during the 1970s and 1980s in response to a desire to reduce peak period congestion, improve air quality and save energy. TDM strategies focused on changing modal split during working days. Therefore, things as transit use, walking and bicycling for work purposes, car sharing, carpooling, vanpooling, congestion charging, car-free planning are most often associated with TDM. All demand management strategies aim to increase the costs of road use either explicitly through charges (parking or congestion charges or fuel prices) or implicitly (through limitations to movement) such that road user costs more closely approach full costs of travel. Demand management and restraint in traffic volumes may be realised by a range of measures, many of them well go beyond the concept of 'traffic management' and often deal with national policy (e.g. fuel pricing) [1].

## 2 Definitions

In its broadest sense, transportation demand management (TDM) is any action or set of actions aimed at influencing people's travel behaviour in such a way that alternative mobility options are presented and/or congestion is reduced (Meyer, 1997) [2]. Some authors define Transportation Demand Management (TDM) as a strategy which aims to maximize the efficiency of the urban transport system by discouraging unnecessary private vehicle use and promoting more effective, healthy and environmental-friendly modes of transport, in general being public transport and non-motorised transport [3]. According to the EU-funded MAX project (Successful Travel Awareness Campaigns and Mobility Management Strategies, MAX 2006), Mobility Management (also called Transport Demand Management – TDM) may be defined as 'a concept to promote sustainable transport and manage the demand for car use by changing travellers' attitudes and behaviour' [4]. Online TDM Encyclopaedia defines Transportation Demand Management (TDM, also called Mobility Management) as a general term for strategies that result in more efficient use of transportation resources [5]. Transportation demand management (TDM) defined by Trombka and Renkema refers to a set of strategies that increase the efficiency of a region's transportation resources including roadways, transit lines, bikeways, pedestrian connections, and parking facilities [6].

## 3 Purpose and goals of TDM

The purpose of TDM is to organise urban mobility more efficiently with an emphasis on sustainable practices. The central idea is to promote a modal shift in favour of more sustainable transport modes, which may be a valid alternative to car ownership. Transportation demand management strategies in urban centres are designed to change travel behaviour. Goals of urban traffic demand management policy are:

- a to reduce traffic congestion; and
- b to reduce adverse traffic related impacts on the city environment.

## 4 Types of TDM measures

TDM measures can be categorized in a variety of ways depending on the researcher's point of view. For example, reference to the work of Meyer yields a list of measures – although some of these are essentially the same measures but applied at different scale (site based, area based or region-wide).

Tanaboriboon separates different TDM strategies into categories, namely, traffic constraints, public transportation improvements, peak-period dispersion, ride sharing, parking controls, and land-use control techniques [7]. One of the more interesting categorizations was by Rosenbloom, who divided essentially different techniques into four categories: social, socio-economic, sociotechnical, and technical approaches [8]. Still another approach was offered by Ferguson, who categorized TDMs according to the four steps of the urban transportation planning process—namely, trip generation, trip distribution, mode choice, and route selection [9]. There are different types of transport policy measures, for example legal policies, economic policies, measures changing the physical context, and informational/educational measures [10], [11]. While Vlek makes a distinction between structural or hard measures (i.e., measures intending to alter the individual's context) and psychological or soft measures (i.e. measures aiming to increase awareness/knowledge) [12], Steg and Vlek distinguish between push measures intending to make car use less beneficial (e.g., prohibiting car use in city centres, raising the tax on fossil fuel, road user charging schemes), and pull measures aiming to improve alternative travel options (e.g., improving the public transport, improving the facilities for cycling or walking, information) [13].

Table 1 Demand Management Tools [2]

TRM Category	TRM	Sub-Category	Examples
Work	<ul style="list-style-type: none"> <li>Car-pool</li> <li>Car-pool</li> <li>Flexi-time</li> <li>Staggered working hours</li> <li>Alternative work hours</li> <li>Home working</li> <li>Parking policies</li> </ul>	<ul style="list-style-type: none"> <li>Subsidies</li> <li>Concessions</li> <li>Part-time work</li> <li>Flexi-time</li> <li>Subsidies</li> </ul>	<ul style="list-style-type: none"> <li>Home working</li> <li>Home office</li> <li>Home office</li> <li>Home office</li> <li>Home office</li> <li>Home office</li> <li>Home office</li> </ul>
Shop	<ul style="list-style-type: none"> <li>Shops</li> <li>Shops</li> <li>Shops</li> <li>Shops</li> <li>Shops</li> <li>Shops</li> </ul>	<ul style="list-style-type: none"> <li>Shops</li> <li>Shops</li> <li>Shops</li> </ul>	<ul style="list-style-type: none"> <li>Shops</li> <li>Shops</li> <li>Shops</li> <li>Shops</li> <li>Shops</li> <li>Shops</li> </ul>
Travel	<ul style="list-style-type: none"> <li>Shops</li> <li>Shops</li> <li>Shops</li> </ul>	<ul style="list-style-type: none"> <li>Shops</li> <li>Shops</li> <li>Shops</li> </ul>	<ul style="list-style-type: none"> <li>Shops</li> <li>Shops</li> <li>Shops</li> <li>Shops</li> <li>Shops</li> <li>Shops</li> </ul>

TDM Encyclopaedia divided the strategies into four major categories: Improved Transport Options, Incentives To Use Alternative Modes and Reduce Driving, Parking and Land Use Management, Policy and Institutional Reforms [5]. While Broaddus divided the strategies into three major categories: Improve Mobility Options, Economic Measures, Smart Growth and Land Use Policies [3]. However categorized, TDM measures are essentially designed with one of three primary goals in mind—namely, increasing the use of alternative modes, discouraging the single-occupant vehicle (SOV) mode choice, and shifting travel demand to off-peak times or alternative routes.

## 5 Applicability of TDM measures in the City of Zagreb

The cities of Ljubljana (Slovenia), Ghent (Belgium), Zagreb (Croatia), Brno (Czech Republic) and Porto (Portugal) joined together in the CIVITAS ELAN project (2008–2012) 'Mobilising citizens for vital cities'. They have agreed on the mission, 'to 'mobilise' our citizens by developing, with their support, clean mobility solutions for vital cities, ensuring health and access for all'.

The CIVITAS initiative helps cities to test and develop an integrated set of TDM measures for sustainable urban mobility [14]. Zagreb as one of CIVITAS cities takes an integrated planning approach that addresses all modes and forms of transport in cities. The aim is to demonstrate that it is possible to ensure a high level of mobility for all citizens, offer a high quality of urban space and protect the environment through sustainable mobility. It is this integrative approach based on innovation, collaboration, research and results-orientation that sets CIVITAS apart.

City of Zagreb should implement 14 TDM measures through CIVITAS ELAN project. Objectives and effects are analyzed individually for each measure.

### 5.1 Energy-recovery system for trams

Aims are to use energy efficient trams in the public transport fleet to make it more attractive to citizens. This will be done by gradually substituting the existing fleet with state of the art air-conditioned low-floor trams. ZET (Zagreb Electric Tram) has concluded the public tender for introducing 70 innovative tram vehicles and they have been integrated into the tram fleet. Thus far more than 700 tram drivers have been trained how to operate new trams.

## 5.2 Clean public transport strategies in the bus network

An aim is to introduce energy efficient buses to the city's fleet to improve the sustainability and quality of the service. Seventeen new CNG articulated buses have been introduced in regular circulation, with a total of 160 clean fuels and energy efficient buses now in circulation: 100 biodiesel and 60 CNG. The majority of bus drivers have been trained on safe driving, as well as on how to operate the new buses. Passenger safety was improved with the installation of safety cameras in vehicles. Noise level of buses is reduced by 3 dB.

## 5.3 Clean public vehicle fleet

This measure aims at introducing energy efficient vehicles and clean fuels, and raise share of clean fuels in public fleet. In 2011 CISTOCA introduced last 3 of total 47 clean biodiesel vehicles into its fleet. Also, from July 2011 all diesel vehicles of CISTOCA's fleet run on B7 and a carefully selected group of MAN vehicles (about 30) runs on B20.

## 5.4 Intermodal high-quality mobility corridor

Aims are to define a high-quality mobility corridor going from the historic city centre towards and across the river, where public transport, bicycle lanes and pedestrians will have priority over individual motorised traffic. The second objective is to conduct traffic and design study for the new terminal. The study for the New Intermodal Passenger Terminal Sava-North was jointly prepared by the City of Zagreb, Croatian Railways – Infrastructure, ZET and NGO BICIKL. The remarks and suggestions from stakeholders and citizens were collected and many were incorporated into the final study. The building permit for the new railway station Buzin, situated on the extended corridor on the southern bank of the river Sava was obtained by Croatian Railways – Infrastructure. The city of Zagreb installed bicycle parking facilities at 12 locations in the CIVITAS ELAN corridor with 120 parking places altogether.

## 5.5 The promotion of electronic public transport tariff system

The purpose of this measure is to introduce an electronic PT ticketing system defining the appropriate model for joint public transportation (bus, tram and rail). The new electronic public transport tariff system implementation in ZET and activities on establishing an integrated transport system, including the tariff union among public transport operators in Zagreb and the two neighbouring counties in the Zagreb region is continuing (the text of the agreement on cooperation in this area is preparing). The ticketing project is in its final phase. A new improved version of the software has been installed. Introduction of electronic ticketing could be used for insight into the needs and habits of users.

## 5.6 Study of congestion charging and dialogue on pricing

The main objective of this measure is to carry out a feasibility study on Congestion Charging, Based on well-established technical solutions of urban road charging, an analysis of applied urban charging strategies, and an analysis of the existing transport system of the city of Zagreb, the proposed preliminary solution in study suggests the introduction of an eco-zone in the city of Zagreb. To enter the zone, drivers need to obtain an annual vignette. The price of the vignette depends on the type of engine, i.e. engines with a lower Euro-standard (bigger polluters) will pay a higher amount. No date has been set yet when the proposal will be submitted to the City Council.

## **5.7 Mobility management for large institutions**

The main objective of this measure is a promotion of more sustainable commuting, which includes carpooling, public transport, cycling and walking. The measure is oriented towards employees and other users within large organisations (i.e. hospitals, factories, universities, schools, municipal and other administration etc.). Data collection on the demonstration corridor of the CIVITAS ELAN project refers to following key data (basic units): modal split, vehicles number, vehicle occupancy, carpooling, etc. Eight dedicated travel plans are set up for different organisations. Web site for carpooling is launched.

## **5.8 Improving cycling conditions**

Currently, cycling has a limited role in Zagreb. Of all trips in the city, cycling merely accounts for one percent. Zagreb aims to develop measures to contribute to the city's sustainable cycling policy and improve cycling conditions in general. Cycling was heavily promoted at a number of events such as mobility week and car-free day, world health week, Zagreb Energy week and the 'Wednesdays in Tram' series. A cycle lane through Savska street is under negotiation and the Bicycle Master Plan as the Zagreb White Paper on Cycling is produced. In close cooperation between Bicikl and the traffic office of Zagreb 60 bicycle racks were installed on several points along the corridor and adjacent streets. Study on a public bicycle scheme in Zagreb is done, but tender for public bicycles are not announced.

## **5.9 Comprehensive mobility dialogue and marketing**

The CIVITAS ELAN Info Point was opened in September 2009, during European Mobility Week. The Info Point is coordinated by NGO ODRAZ in cooperation with ZAGREB and all partners. Nineteen presentations followed by discussions have been held up until December 2011 within the 'Wednesdays in tram' cycle. One of the main activities in the later stage of the project implementation were meetings with different target groups of citizens. Zagreb has nourished a dialogue with interested groups and individuals via a Facebook group established in 2010 which counts 524 fans as of December 2011. Regular communication with the media has been established, coordinated and maintained. This has resulted in 31 press releases and a list of interested media and journalists. The first concrete results of the project's activities have started opening new space for collaboration with specialised media and expert publications.

## **5.10 Safety and security for seniors**

Though older people are a growing user group, they are not usually considered in urban transport policies in Zagreb. The first training on safety and security for seniors took place in a senior citizens' home in March 2010. Questionnaire is prepared to be filled in by senior citizens, which deals with their public transport habits, safety, communication with operators etc. Possible users were informed of the benefits of new public transportation vehicles, such as the introduction of low-floor trams and buses.

## **5.11 Security improvement in public transport**

Public transport vehicles are occasionally subject to vandalism by passengers. Staff training was given on how to use surveillance equipment and the results from video surveillance in public transport vehicles and at tram and bus stops. New vehicles were promoted in media. It appears that the majority of customers are satisfied with the new trams and buses, which are equipped with CCTV.

### 5.11.1 Freight delivery restrictions

Freight delivery in Zagreb is controlled by different regulatory systems. However, these systems have either been disrespected or not been implemented properly in the past. Before introducing the proposal of new freight delivery measures, several workshops with relevant target groups has been conducted. The aim of these workshops was to inform stake holders with a new regulation of delivery, and to collect the suggestions of any betterment of the new regulation system before the implementation phase. After the analysis of all collected data the proposal of new delivery regulation system has been made and it was sent to the city authorities in May 2011. For now there is no response of authorities on the implementation of new delivery regulations that is prescribed by the project.

### 5.12 Public transport priority and traveller information

This measures objective is to give priority at intersections to public transport, and to provide passengers real time information. Data on the present situation has been collected and simulated using PTV Vision Planning and Simulation software. The signal equipment on the Savska corridors was analysed and it was found that there is a very low availability and interoperability of equipment on different intersections because the equipment is outdated. The concept and architecture of the adaptable traffic light system for public transport priority has been presented. At the beginning, it was planned that the measure will be implemented across the entire Savska street.

### 5.13 Comprehensive safety and security strategies

Safety and security is an ongoing area of public transport concern, but businesses and the government should be involved too. Zagreb will carry out safety audits with local transport operators to assess the current situation and identify improvements than can be made. A matrix for safety and security audits was prepared and data was collected to compare the technical situation of providing security in various cities, as well as user satisfaction with the existing service. Many activities in the field of safety and security in public transport have been implemented in Zagreb, with CIVITAS being used as a platform for sharing experiences, and ideas on how to improve the situation in the field.

## 6 Conclusion

Sustainable mobility with transport demand management strategies is a prerequisite for achieving a better quality of life and greater social cohesion in cities. People should have easy access to basic facilities in order to benefit from their work and leisure activities, in a comfortable, safe and healthy environment, minimising their contribution to pollution and congestion. Transport demand management should be based on an integrated approach whereby a package of well-balanced measures is implemented, rather than single initiatives with a low likelihood of being effective. Sustainable Urban Mobility Plans may provide a sound and appropriate framework for such integration. Citizens should be a part of the process leading to a Mobility Management strategy. This is fundamental for securing public acceptability of the proposed transport demand management measures. Examples of TDM measures in the City of Zagreb show the success of most measures. It is important to emphasize that the excellent co-operation is achieved through the CIVITAS-ELAN project between stakeholders who are key to decision-making or planning the transport system of the City of Zagreb.

## References

- [1] Cracknell, J.A.: Experience in Urban Traffic Management and Demand Management in Developing Countries, Final Report, Department for International Development, UK, 2000.
- [2] Meyer, M.D.: Demand management as an element of transportation policy: using carrots and sticks to influence travel behavior, *Transportation Research Part A – Policy and Practice* 33 (7–8), pp. 575–599, 1999.
- [3] Broaddus, A., et.al.: *Transportation Demand Management*, Training Document, Federal Ministry for Economic Cooperation and Development: Eschborn, Germany, 2009.
- [4] Silvia, M., et.al.: *Mobility management*, Directorate general for internal policies, Policy department b: structural and cohesion policies, Transport and tourism, Brussels, November 2009.
- [5] VTPI, Online TDM Encyclopedia, Victoria Transport Policy Institute, Canada, [www.vtppi.org](http://www.vtppi.org), 09.02.2012.
- [6] Trombka, A. & Renkema, J.: The Office of Legislative Oversight's review of transportation demand management in Montgomery County, December, 2008.
- [7] Tanaboriboon, Y.: An Overview and Future Direction of Transport Demand Management in Asian Metropolises. *Regional Development Dialogue*, Vol. 13, autumn 1992.
- [8] Ferguson, E. *Transportation Demand Management—Planning, Development, and Implementation*. *APA Journal*, autumn 1990.
- [9] Rosenbloom, S. *Peak Period Traffic Congestion: A State-of-the-Art Analysis and Evaluation of Effective Solutions*. *Transportation*, Vol. 7, 1978.
- [10] Gärling, T. & Schuitema, G.: Travel demand management targeting reduced private car use: effectiveness, public acceptability, and political feasibility. *Journal of Social Issues* 63, pp. 139–153, 2007.
- [11] Steg, L.: Factors influencing the acceptability and effectiveness of transport pricing. In: Schade, J., Schlag, B. (Eds.), *Acceptability of Transport Pricing Strategies*. Elsevier, Oxford, pp. 187–202, 2003.
- [12] Vlek, C.A.J.: Collective risk generation and risk management: the unexploited potential of the social dilemma paradigm. In: Liebrand, W.B.G., Messick, D.M. (Eds.), *Frontiers in Social Dilemma Research*. Springer, Berlin, pp. 11–38, 1996.
- [13] Steg, L. & Vlek, C.: The role of problem awareness in willingness-to-change car use and in evaluating relevant policy measures. In: Rothengatter, T., Carbonell Vaya, E. (Eds.), *Traffic and Transport Psychology. Theory and Application*. Pergamon, Oxford, pp. 465–475, 1997.
- [14] CIVITAS Initiative ('City-Vitality-Sustainability', or 'Cleaner and Better Transport in Cities'), [www.civitas.eu](http://www.civitas.eu), 19.02.2012.





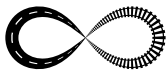

## NEW TRANSPORTATION SYSTEM OF THE CITY OF DUBROVNIK

Damir Pološki<sup>1</sup>, Željko Stepan<sup>2</sup>, Igor Majstorović<sup>2</sup>

<sup>1</sup> Polytechnic of Zagreb, Professional Study Program of Civil Engineering, Croatia

<sup>2</sup> University of Zagreb Faculty of Civil Engineering, Croatia

### Abstract

The paper presents the idea of introducing a new transportation system in the city of Dubrovnik. The efficient solution of the problem of fast public mass transport connecting the port of Gruž and the Čilipi airport with the old center of Dubrovnik could be found in the metro system. The need of introducing the metro system based on the integral transport model of Dubrovnik is discussed. The paper analyzes the evaluation of the planned scenario by comparing transport effects of the new system through savings in the system and investments of the new integral transport system. The evaluation results proving the purposefulness of the idea of new transportation system design in the city of Dubrovnik in the future are discussed.

*Keywords: public transport, transport modeling, transport planning, transport effects, metro, evaluation and selection of solutions*

### 1 Introduction

The transportation system of the city of Dubrovnik as a world tourist destination confirms its inefficiency with traffic congestions during summer, the period with the greatest number of tourists. The problem of fast and mass transport cannot be solved by reorganizing and reconstructing the main roads for the private transport. Within the current public transportation system including bus and taxi services there is no solution in finding the fast transport connection between the Gruž port, the old City and the Dubrovnik airport which are points with the busiest traffic. The paper presents the idea of introducing a new transportation system of the public transport improving the efficiency of the integral transport model of the city of Dubrovnik. The evaluation of the scenario by introducing a new transportation system which entirely redesigns the traffic in the City based on calculations of transport and economical effects confirms the purposefulness and justification of the idea.

### 2 Traffic model and methodological approach

The traffic model observing the idea of the new transportation system is a contemporary traffic model of integral transport for the area of the city of Dubrovnik. The traffic model was performed by the software package VISUM. Both models of the existing and the future transportation systems were made. The model includes the transportation systems of private transport, public bus transport as well as track transport system.

The model is made for the base year 2011 and the following three periods:

- the phase up to 2016
- the phase from 2016 to 2021
- the phase from 2021 to 2031

In the traffic model of private transport the network is organized into motorways, state roads, county roads and local roads, and in the City area the main city roads, city roads, collector roads and the other kinds including pedestrian roads.

The modeled network of the public city and suburban bus transport include all the bus lines, stops and schedules. The new transportation system of light metro is precisely routed taking into consideration the location and the height. The stops are also included into the model. The overview of the public transport network in the model is shown in the Table 1.

**Table 1** The overview of public transport network

	NU	Public
Number of lines	10	4
Routes length [km]	718,1	75,5
Network length [km]	424,5	26,1
Number of stop points	120	18

The trip distribution by trip modes for the base year 2011 and the planned year 2021 is shown in the Table 2. :

**Table 2** Trip distribution by trip modes

Distribution of trip by mode	Number of trip			
	2011		2021	
Public transport	56.264	27,85%	73.988	26,89%
Private transport	101.705	42,74%	117.170	42,58%
Pedestrian transport	70.000	29,42%	84.000	30,53%
<b>Total</b>	<b>227.969</b>		<b>275.158</b>	

### 3 Solution description and characteristics of the new transportation system

There have been two recent suggestions for connecting the city of Dubrovnik with the Dubrovnik airport with a track system.

The first idea was to connect Dubrovnik with the airport through Cavtat by a single track electrified railway 21,8 km long. The facilities (tunnels and viaducts) make 60 % of this route [1].

Another idea is to build the track system connecting the Gruž port and the Dubrovnik airport. This proposal sees the solution in the double track light railway 24,1 km long, which makes 73% of the total route in the terrain [2].

Both of these suggestions deal with construction possibilities disregarding the quality of the built environment which does not allow the implementation of the new infrastructure corridor. The new track system described here includes a double track light metro from the Gruž port to Viktorija and a single track light metro from Viktorija to the Dubrovnik airport as well as from the Dubrovnik City to Babin kuk. The plan is to construct two tracks at the metro stops. The technical solution derived from the conceptual design to present the validity of the light metro. The project was based on DOF 1:5.000, DOF 1:2.000 and a digital model of terrain 1:25.000. It shows that a sector in the Srebreno area allows and requires the route above the terrain (partly as an embankment, mostly as a viaduct) while other parts of metro would be under the terrain. The sector above the terrain covers 7,3 % of the total metro route. Since the rock mass characteristics are made of limestone deposits the plan is to excavate one tube for a single track and a double track metro system.

The cross-sections of a single track and a double track light metro are shown in the Figure 1.

The lines of the new track system are marked with geometric characteristics of a light metro, i.e. with the horizontal radius of more than 100m and the maximum longitudinal slope of 4%. The route of light metro is shown in the Figure 2.

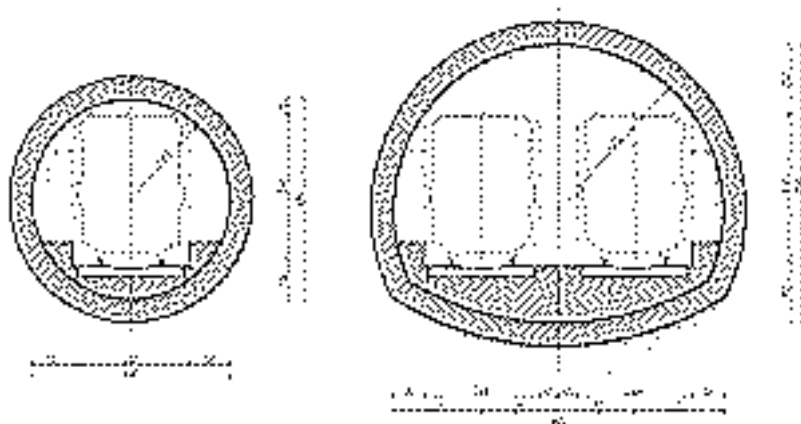

Figure 1 Cross-sections of a single and a double track light metro



Figure 2 The route of light metro in the Dubrovnik area

Table 3 Length characteristics of the metro routes

Route	No.	Name	Distance	Height	Altitude
M1 Luka Gruž - Viktorija	1	Gruž	0+020		-13,09
	2	Tržništa	0+952	932	-12,85
	3	Gruško polje	1+572	620	-11,90
	4	Dubrovnik "City"	2+268	676	-1,79
	5	Stara bolnica-kampus	2+877	629	8,51
	6	Ivo grada (Ruža)	3+511	634	0,86
	7	Viktorija	4+821	1.370	38,94
	Total		4.901		
M2 Viktorija - Račna luka Dubrovnik	8	Hotel Belvedere	5+865	984	68,52
	9	Dubac (P&R)	8+199	2.395	107,63
	10	Čibrač	9+102	908	71,51
	11	Seobreno	11+321	2.219	12,14
	12	Mlini	13+300	1.979	66,16
	13	Plat	15+756	2.457	66,85
	14	Cavtat	18+304	2.747	19,52
15	Čilipi	22+480	3.976	139,42	
	Total		16.555		
M3 Babin kuk - Dubrovnik City	1	Babin kuk	0+020		35,90
	2	Lapad polje	1+232	1.212	3,95
	3	Bolnica	2+054	823	31,64
	4	Čokplino	2+797	743	18,06
	5	Dubrovnik City	4+006	1.209	-1,29
	Total		4.026		
	Total		25.582		

The solution includes 3 metro routes with the following working titles:

- M1 Luka Gruž – Viktorija,
- M2 Viktorija – Dubrovnik Airport,
- M3 Babin kuk – Dubrovnik City.

The length characteristics and stop points are shown in the Table 3. The new metro system provides the solution for the mass public transport in the City zone (route M1) as the double track system, for connecting the City with the Dubrovnik airport (route M2) and with Babin Kuk (route M3) as a single track metro system. The route is set in the way that it connects all the tourist attractions of the City and all the stop areas for taking another transport mode, and it also connects the City with the planned Park&Ride system in the Dubac area.

## 4 Evaluation of the new transportation system

The evaluation of the new transportation system was conducted by determining the efficiency of the future transport network valued within the integral transport model. The efficiency of the light metro was determined by the calculation of effects of the transportation system and the costs of its construction throughout particular time periods.

The efficiency calculations include transport indicators both for the public and private transport which were transformed into money values in the analysis of benefits and costs.

For public transport:

- Transport indicators
  - Duration of travel (number of people - hours/year)
  - Vehicle costs without energy (millions euro /year)
  - Energy expenses
- Investment indicators:
  - Infrastructure maintenance costs
  - Investment costs including:
    - price of land

- construction of roads
- equipment for roads
- other appliances

For private transport:

- Transport indicators
  - Time costs (millions euro /year)
  - Vehicle costs (millions euro /year)
- Investment indicators:
  - Infrastructure maintenance costs
  - Investment costs including:
    - price of land
    - construction of roads
    - equipment for roads
    - other appliances

The efficiency of this idea is based on the cost-benefit analysis of the performed action in the transport system (the planned situation - doing something/moving forward) in comparison with the costs in the case the planned action is not performed (keeping the status quo – the minimum).

Apart from the public transport scenario, the scenario of the needed actions in the private transport was analyzed in the evaluation process.

The introduction of the light metro in the zone of the new transportation system reduces the number of private travels by 15% and it consequently increases the public transport for that number of travels.

The Table 4 shows the efficiency list of introducing the light metro in the public transportation system.

The success of the planned action in the public transport is shown in the display of traffic load in the transport network in the city of Dubrovnik (see Figure 3.) There are several times more passengers on the route M1 of the metro in comparison with the number of passengers in the public bus transport.

The economic and financial analysis included the calculations of: savings in the traffic system, the net present value (NPV) in the year of starting the investments, the internal rental rate (IRR) and the cost-benefit factor (C/B factor). All the indicators present the criteria for the justification mark of a specific investment implementation, a specific action in the infrastructure system. The net present value being higher than zero proves the acceptability of the planned action.

Inlet parameters for the calculation of economic and financial indicators are discount rate of 5%, and the indirect benefits were not taken into consideration.

The calculations of the indicators for each scenario of the light metro network are shown in the Table 5.

The calculations show that the route M1 Luka Gruž – Viktorija in the scenario S-2031\_PSD\_ME-TRO-04 is profitable with IRR of 17,42% and positive NPV of 76,75 It needs to be emphasized that the savings in the transportation system of this scenario are prevailing in comparison with other scenarios. The saving is 10,38 million € per year. The proven justification of the metro route M1 Luka Gruž-Viktorija indicates the need to intensify all the activities included in the implementation of this idea.

Table 4 Overview of service kilometers and travel duration by routes of light metro

Route	Component	Description	Scenario			Difference
			Bus	Bus	MTPO	
M1 + M2 + M3 (without cruising)	Cost component	Length of infrastructure [km]	341,000	341,000	26,446	-26,446
	Benefit component	Vehicle service kilometres [km/day]	8.957	8.654	6.816	-6.513
		Duration of trip [hour/day]	10.588	5.163	3.732	1.693
M1 + M2 + M3 (with cruising)	Cost component	Length of infrastructure [km]	341,000	341,000	26,446	-26,446
	Benefit component	Vehicle service kilometres [km/day]	8.957	8.654	6.816	-6.513
		Duration of trip [hour/day]	12.076	5.450	4.209	1.817
M1 + M3 (with cruising)	Cost component	Length of infrastructure [km]	341,000	341,000	8,847	-8,847
	Benefit component	Vehicle service kilometres [km/day]	8.957	8.654	1.683	-1.380
		Duration of trip [hour/day]	12.076	10.381	1.886	-191
M1 (with cruising)	Cost component	Length of infrastructure [km]	341,000	341,000	4,860	-4,860
	Benefit component	Vehicle service kilometres [km/day]	8.957	8.957	713	-713
		Duration of trip [hour/day]	12.076	10.924	1.481	-329
M1 (without cruising)	Cost component	Length of infrastructure [km]	341,000	341,000	4,860	-4,860
	Benefit component	Vehicle service kilometres [km/day]	8.957	8.654	713	-410
		Duration of trip [hour/day]	10.588	10.811	414	-637

Table 5 Economic and financial indicators for the proposed scenarios of the light metro network

No.	Scenario	Network Year	Without cruising	With cruising	Investment [€M]	Economic			NPV [€M]
						NPV [€M]	IRR [%]	Pay back [yr]	
1	S-2021_PSO_NETWORK-0040-0040	network Year 2021 **	without cruising	with cruising	380,468,258	7,383	301,17	0,357	-
2	S-2021_PSO_NETWORK-0040-0040	network Year 2021 **	without cruising	with cruising	380,468,258	7,875	186,62	0,592	-
3	S-2021_PSO_NETWORK-0040-0040	network Year 2021 **	without cruising	with cruising	346,795,477	8,669	20,08	1,168	6,005
4	S-2021_PSO_NETWORK-0040	network Year 2021 **	without cruising	with cruising	34,108,254	10,380	76,75	3,080	17,589
5	S-2021_PSO_NETWORK-0040	network Year 2021 **	without cruising	with cruising	34,108,254	8,820	88,47	1,882	16,126

\* without cruising  
\*\* with cruising

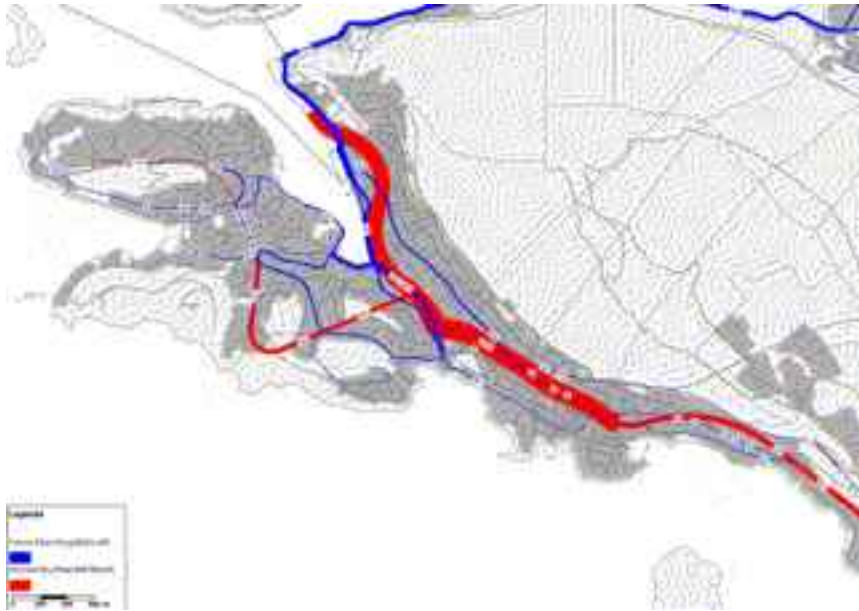

**Figure 3** Traffic load in the public BUS and METRO network

## 5 Conclusion

The introduction of any kind of a new transportation system into the traffic system of an area or a city has to be based on a contemporary traffic modeling of integral transport and economically justified and not only on the analysis of project feasibility and its technical characteristics.

The paper presents the introduction of light metro in the traffic system of the city of Dubrovnik which are based on the basic principles of modern traffic planning which deals with issues such as the use of space, integration of transport systems, traffic safety, sustainability, reduced traffic congestion, reducing the harmful substances emissions, innovative technologies, convenience for users, innovative financing as well as modern construction technologies.

The results show that the planned underground transport network in Dubrovnik offers positive economic indicators based on which further elaboration of technical solutions can be made. Consequently, the ideas from the organization and implementation aspects could be realized by the year 2021 which is an assurance of the sustainable development of traffic in the city of Dubrovnik.

## References

- [1] Lakušić, S., Haladin, I., Galijan, I.: Željeznička pruga Dubrovnik-Cavtat-Zračna luka Čilipi, Projektiranje prometne infrastrukture, Dani prometnica 2011, pp. 511-537, 2011.
- [2] Kolić, D., Hadžiahmetović, E., Škerbec, E.: Dubrovnik city light rail line Gruž-Čilipi, 1st ITA SEE "Using Underground Space, Dubrovnik, 2011.
- [3] Promel projekt d.o.o. Zagreb, Građevinski fakultet Sveučilišta u Zagrebu: Prometna studija Grada Dubrovnika, Zagreb, 2012.





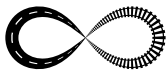

## TRAFFIC LIGHTS ON CONSECUTIVE INTERSECTIONS AND PEDESTRIAN CROSSINGS ALONG LINEAR SETTLEMENTS LOCATED ON NATIONAL ROADS

Alina Burlacu<sup>1,2</sup>, Mihai Dicu<sup>1</sup>, Valentin Anton<sup>1</sup>

*1 Technical University of Civil Engineering Bucharest, Romania*

*2 SC Search Corporation SRL – Traffic Design Department, Romania*

### Abstract

In Romania, with time, settlements located along the main roads have developed and transformed into linear towns, with significant local and connection traffic, important administrative, economic, commercial and touristic activities concentrated in the central area, as well as pedestrian traffic of over 200 pedestrians per hour in the main pedestrian crossings on the route. The object of the present study is made by a series of junctions situated on National Road 1 in Busteni town, on a dangerous road sector. For this study, traffic measurements, simulations and suggestions for improving the existing situation were made.

Based on the simulated traffic flows, there were performed capacity analysis with PTV Vissim and Trafficware Synchro softwares, and were developed appropriate planning solutions for the intersections, resulting in tables with extracted performance indicators based on micro simulation of the traffic values. Also planning solutions for horizontal design and proposals for traffic lights were made for junctions that can not operate under priority traffic on one direction or which are presenting traffic safety risk.

Based on the traffic data, it was taken in consideration the necessity to make planning proposals and to develop design solutions immediately applicable, with minimum intervention. Solutions will refer to the geometric planning of the intersections, but with new plans and timings for traffic lights, including proposals for new equipment; regulating the traffic flow: development/ refurbishment of intersections and pedestrian crossings; optimization of routing programs in order to achieve a higher level of service and more efficient traffic control indicators; segregation of pedestrian movements by vehicles traffic, implementation of physical devices to lock / channel the traffic.

*Keywords: traffic study, linear settlements, road traffic, intersections, road safety*

### 1 Introduction

Linear village or linear locality is that kind of area where humans are developing activities along a main road. This type of area is common in Romania along the national and county roads. It can be also observed in other Central or Western European countries and it is common to small size cities/villages, especially where geography and/or topography of the area does not allow much expansion on the side.

Specific human activities have been developed in time along the main central road: housing, shopping, services, recreational and economic related ones (small industries). Beside this, as the time has passed, the linear village is extended on specific areas not so close to the main road, but getting access to it via the local streets or roads. Thus, it is obvious that this kind of main central road get more functions to be fulfilled: flow function (to ensure a reasonable

travelling speed and Level Of Service), distributor function (to ensure the access to lateral developed areas) and access function (to ensure direct access to the activities developed at the roadside directly).

This mixture of functions gives the opportunity to different traffic participants with different purposes to use the main road. Both vehicles and vulnerable traffic participants like pedestrians, bicycles and children make use of this road, either to travel along it when footways are not provided or by crossing it to get access to specific locations as schools, markets, shops, banks, restaurants, etc. Thus, first and the most critical conflicts are given by the interactions between vehicles and vulnerable road users: pedestrians, bicycles and children.

The national road section DN 1 placed on Busteni locality territory is requested for the generated traffic by the local tourist activities, but also serves to others important tourist area in the neighbourhood: Sinaia, Azuga, Predeal.

Figure 1 shows the traffic evolution trend on the national road section DN1 that includes linear village Busteni, as resulted from the traffic study performed by Search Corporation for Bucharest – Brasov motorway in hypothesis without motorway.

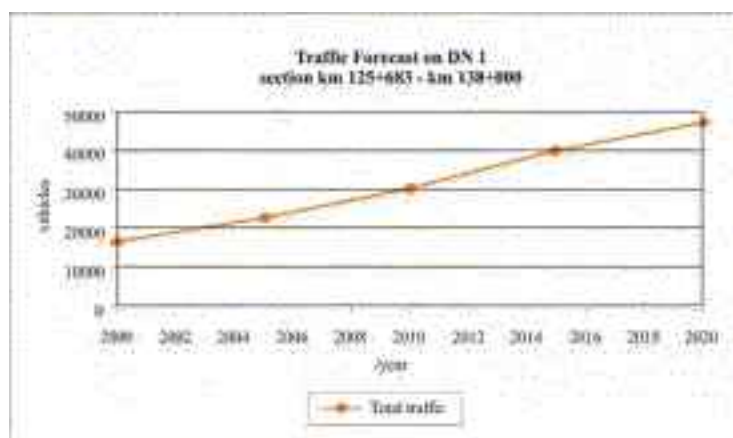

Figure 1 Traffic forecast on DN 1

## 2 Traffic data

The project team from Search Corporation has proceeded on a field survey in Busteni during the month of November 2010, to identify the main characteristics of DN 1 and of local streets and access areas linked to the main road, in order to establish the traffic counting locations and to define the working procedures and schedule for the traffic counts.

The traffic data collection was carried out through manual measurements in DN1 sections and on 10 local streets/roads where they cross DN1, and also through automatic counts in five specific sections of DN1.

The automatic traffic counters can identify the type of vehicle (car or truck) and they have been scheduled to register the traffic flows for two weeks, four days per week (Thursday, Friday, Saturday and Sunday), in order to collect information to obtain the traffic pattern (per hour, day, week). One of the DN1 sections where traffic is registered automatically is doubled by the manual counts in order to have a more detailed distribution of traffic flows by type of vehicles.

## 2.1 Vehicle traffic

At the survey sections, it was found that vehicles travel with mean speed between 70 km/h at hours with low traffic (in the night and early in the morning) and 30 km/h at peak hours (between hours 10:00 – 18:00).

The traffic volume registered during working days is higher than the traffic volume registered during week-ends, even though no significant peaks are noticed. Figure 2 gives the daily variation of the total traffic and variation of the heavy vehicles traffic recorded on DN1 at a survey section placed in the linear village Busteni (between Poiana Tapului and Busteni Center).

The peak hour is Friday in hour gap 16:00 – 17:00. Figure 2 gives hourly intervals with high traffic volume, where the peak hour is included. The maximum hour traffic is 8% of the total traffic on 24 hours.

Given the Annual Average Daily Traffic (AADT) level, in November (when the traffic survey was made) a lower traffic level is recorded. The maximum traffic volume corresponds to August. Using the program Synchro, a simulation of the present traffic on the road network of the linear village Busteni was made and it was found that given the size of the vehicle flows from survey sections, in average, the transit is in this interval of time:

- for the direction Sinaia – Predeal, 80% of total
- for the direction Predeal – Sinaia, 73% of total
- the rest being local traffic of Busteni locality or connection traffic between this and environment territory.

About traffic capacity we can specify that the vehicle traffic on DN1 at peak hour at level of August exceeds significantly the traffic capacity, relating to the Norm for roads capacity, or to STAS for streets capacity.

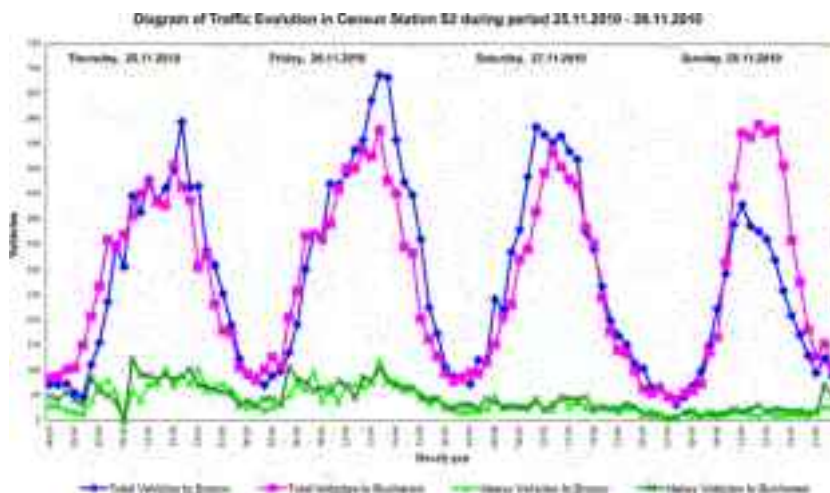

Figure 2 Diagram of daily traffic evolution

Concerning the capacity of the main intersections from DN1, where the traffic from accesses has values over 100pcu/h, this is exceeded especially due to the high traffic values on DN1. In these intersections, especially for left turn, of entering on DN1 from access, the level of service resulted from calculus is 'F', as for the whole intersection. Thus for a better understanding of the way these intersections from DN1 operate, a dynamic simulation of the traffic was made with the programs Synchro and PTV Vissim, taking into account the present layout of the intersections, the vehicles and pedestrians traffic. Simulations were made both for a mean traffic at AADT level, and for maximum traffic corresponding to August.

## 2.2 Pedestrian Traffic

The pedestrian traffic has significant values of over 200 pedestrians per hour in November and, 400 – 500 pedestrians/hour respectively, in August, at the peak touristic season, mainly at Busteni Centre area. This generates important problems related to vehicle flows (queues of vehicles on DN1 due to frequent crossing of the pedestrians at zebras). Another area, where pedestrian traffic is high enough to generate conflicting locations with risk of accident, is the area Centre – North.

## 2.3 Traffic environment, parking capacity

Taking into account that the linear locality Busteni is an appreciated touristic spa, one of the problems it faces especially in the summer time is finding a parking lot, associated with the need of information and guidance to important places.

Although in November, the month when traffic data were collected, the parking capacity wasn't totally used, the deficit of parking lots from periods with maximum traffic generates malfunctions of traffic running.

By instance, especially in the central area of the town, in the neighbourhood of some economic units or commercial centres, local widening were made of about 1,5 – 2 m, that are used as parking lots, this involving additional manoeuvres on traffic lane. Of course, it can be possible in some situations, to be a favourable element for an accident and as result these parking lots should be eliminated and allocated in some other place, with access from lateral streets.

## 3 Traffic study

The collection and processing of the counted data from the analyzed junctions allow us to determine the maximum hourly traffic flows, values which are the basis in dimensioning intersections capacity. Graphically, the maximum hourly traffic flows are represented by traffic diagrams.

Based on simulated traffic flows, capacity analyses were made using the program Synchro and solutions were developed in order to obtain an adequate planning of the intersections. This software allows, through micro simulation of traffic values, to obtain a large number of performance indicators of junctions. Based on these indicators, planning and traffic light solutions for each intersection can be compared and placed on levels of service (LOS), so that the optimal solution can be highlighted.



Figure 3 Example of traffic light simulation in Synchro

The analysis module of the program Synchro was used for the capacity analysis in the intersections proposed for traffic lights. In this analysis module we used as input data the following parameters: traffic light cycle length, the share of green light duration for each phase of the cycle, the existent geometry of the junction, traffic flow on each access and travel direction, and the output data for each junction consists in the level of service, the average delays, queue length, emissions of pollutants.

The program Synchro has the following advantages:

- introducing input data in the design module, such as existent geometry of the junction and traffic volumes on each access and travel direction, in order to obtain optimal cycle, the optimal sequence of phases and the optimal duration for green light in each phase (Figure 3);
- for a particular cycle of traffic lights and a particular volume of traffic, in the evaluation module the output data is the cost for each road user.

As a result of the tests performed with the program Synchro for each analyzed junction, it has been developed an outline with the functioning of the intersection on traffic phases, and also an ongoing plan of phases in characteristic periods for working or non-working days, in different times of day (peak hours and normal hours).

Regarding the optimization of the intersections so that each one operates independently on local area, it was analyzed the current arrangement and improving solutions were elaborated according to the estimated traffic circulation and current traffic regulations, transposing the concepts used for re-organized intersections into detailed solutions.

For the timing of the traffic circulation on the axis, proposals were made in order to modify the actual geometry of the junctions, such as left turn lanes or right turn lanes, as shown in the figure below.



**Figure 4** Example of proposed planning solution

Also, uneven solutions for the crossing over of the pedestrians were taken into consideration, such as footbridges or pedestrian subway passages. From traffic analysis they turned out to be ineffective and not feasible for two reasons: first of all, a highway is designed to take over the transit traffic from DN 1, so the traffic flow will considerably decrease; second, the width of the national road in Busteni is between seven and nine meters, so most pedestrians will rather cross over illegal rather than walk three or four times more on a footbridge/ underground pedestrian passage.

At the same time an analysis was made regarding the traffic lights plans and the traffic circulation on the main axes of movement. Based on this analysis there were identified and established the conditions under which the right turn can be removed from under traffic lights. To improve the traffic circulation on the axes, especially on those with one way or on traffic routes separated by median large green areas and wide interior storage space, the timing of traffic lights in a system of 'green line' was investigated.

The calculus of the optimal cycle length and of the duration for 'green line' for a main corridor was also made with the program Synchro. After entering the input data set in the Linear Scheme, the program provides data regarding the maximum band width of 'green line' for a route, according to the traffic light cycle, the splits on the corridor direction (green light on the corridor compared to the entire cycle) and a certain traffic speed (resulting as optimal) to go through the corridor.

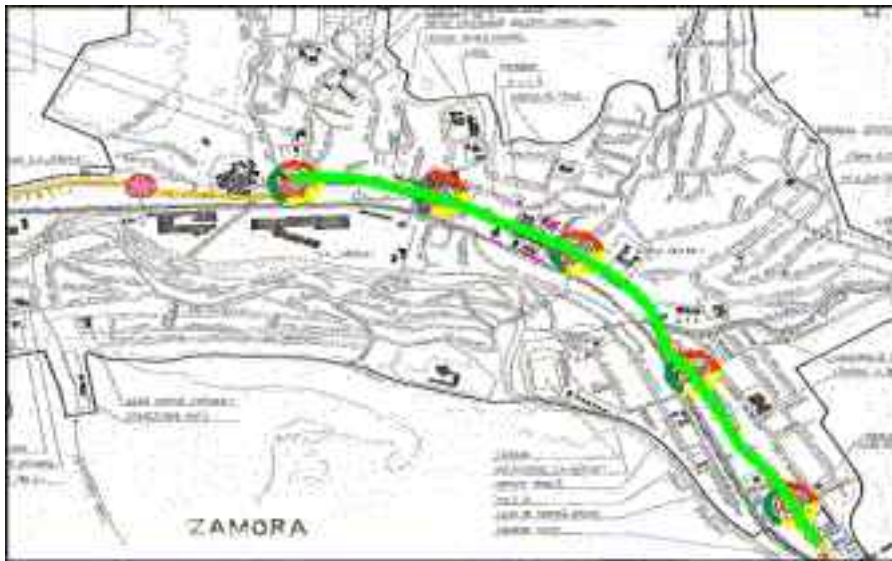

Figure 5 Green line of a continuous flow between the analyzed junctions

Also, for pedestrian crossings from the routes between the intersections was analyzed their continued appropriateness, and for each case proposals for planning, traffic lights or demolition were made.

## 4 Conclusions

Analysing the data from the exported tables with performance indicators, it is noticeable that the proposed planning solutions for the junctions not only will contribute to a better channelling of the traffic flow and a better order in the movement of vehicles and pedestrians, with significant road safety benefits, but also to a significant reduction of the duration of travel.

In this regard, the following were developed: planning solutions in the horizontal plane, immediately applicable, where appropriate; proposals for traffic lights in intersections that don't function properly or present traffic safety risks; optimization of routing programs in order to achieve a higher level of service and more efficient traffic control indicators; segregation of pedestrian movements by vehicles traffic; implementation of physical devices to lock / channelling the traffic.

By introducing traffic lights to the analyzed junctions and their correlating functioning, the traffic safety is improved due to the clear regulation regarding the alternative occupation of the roadway by vehicles and pedestrians. At the same time, the traffic flow is improved throughout the network and the time travel is reduced, along with the waiting time across the junctions and the emissions of pollutants.

## References

- [1] Search Corporation & Finnroads: Road Safety Pilot Project on National Road 1 Bucharest Brasov, 2004.
- [2] Search Corporation & NEA: Road Safety Pilot Project in Linear Village Busteni, 2004.
- [3] Search Corporation: Project for Planning of Junctions in Linear Village Busteni, 2011.
- [4] David Suciu, Anca Damian: Road Safety Pilot Project in Linear Village Busteni, Roads and Bridges Magazine, no. 8, no.9, no.10, 2004
- [5] Transportation Research Board of the National Academies: Highway Capacity Manual, 2010.
- [6] Trafficware: Traffic Signal Software – User Guide, Synchro Studio 7, Synchro plus SimTraffic and 3D Viewer





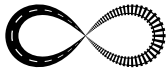

## REQUIREMENTS FOR HIGH QUALITY CYCLING INFRASTRUCTURE DESIGN

Tadej Brezina<sup>1</sup>, Nikolaus Ibesich<sup>2</sup>, Martin Niegler<sup>3</sup>, Helmut Lemmerer<sup>1</sup>

<sup>1</sup> Vienna University of Technology, Institute of Transportation,  
Research Center of Transport Planning and Traffic Engineering, Vienna, Austria.

<sup>2</sup> Umweltbundesamt GmbH, Department Transport and Noise, Vienna, Austria.

<sup>3</sup> Komobile w7 GmbH, Vienna, Austria.

### Abstract

Cycling is increasingly recognized as a significant component of an integrated urban transport system. Following leading bike cities like Copenhagen or Amsterdam, many other European cities have been working to improve conditions for cycling. Thus, two trends can be observed: a) a general increase of bicycle use and b) in particular an increase of pedelecs. The rising popularity of cycling calls for an appropriate infrastructure supporting both intra-city cycling and suburbia-city commuting.

This paper presents two results from an Austrian research project on new perspectives for cycling in the suburban-urban relation [1]. On the one hand this paper presents requirements for providing a high quality cycling infrastructure, on the other hand it introduces a new organizational element for road junctions – the 'Viennese diagonal'.

The design and construction requirements focus on capacity, speed and curve radii and the effects of surface quality on body energy expenditure.

The 'Viennese diagonal' is especially aimed at top-level high capacity cycling routes and allows a 'one-step crossing' in contrast to the traditional and widespread 'two-step-crossing', where cyclists need to wait at least one period at traffic lights, are being confronted with limited space and sharp turns before they can go on, because the cycling infrastructure continues on the other side of the road – similar to pedestrians.

*Keywords: cycling infrastructure; pedelecs; design requirements; intersection design; cycling improvement*

### 1 Introduction

Many city transport concepts proclaim that cycling will play an important role in their future transport regimes, e.g. the Vienna Transport Masterplan 2003 [2].

As the bicycle traffic shares of Vienna have increased in recent years, also the average daily traffic (ADT) of cyclists is considerably high and, for example, counts more than 5,000 bikes at the bikeway next to Vienna Opernring. (Fig. 1); by comparison: the main road's ADT counted 27,300 motorized vehicles. The latest impact of electrically assisted cycling is, among others, one of the reasons for this upward trend as Pedelec sellings for Austria show (Fig. 2).

Pedelecs are attractive because they reduce body energy expenditure by utilizing electric power as a support. The path-time diagram shows the pedelec's ability to improve a regular bike's range of attractiveness. This improvement is about a factor of 3.3 (Fig. 3) and results from the equal modal access distance but an improved average speed (from 15 to 20 km/h) due to external power.

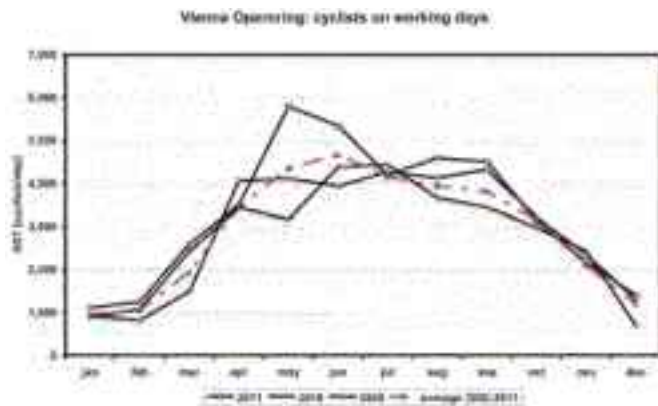

Figure 1 ADT of cyclists on Vienna Opernring route from 2009 to 2011. Data: www.nast.at.

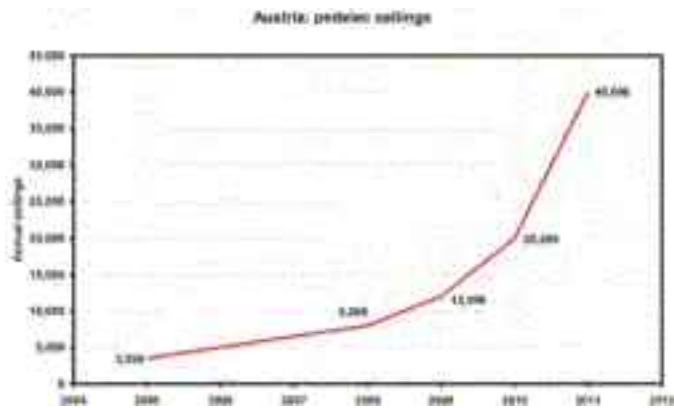

Figure 2 Recent Austrian pedelec sellings, 2011 data is preliminary. Data: BMVIT & WKÖ.

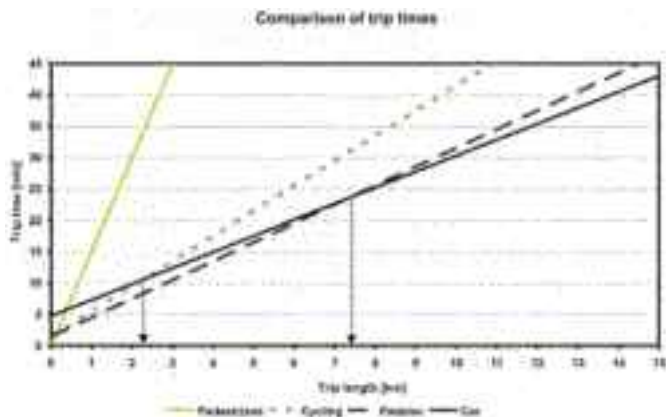

Figure 3 Trip time comparison of regular bikes and pedelecs with other cars and pedestrians. Modified after [3–5].

Apart from a convenient gear, be it bike or pedelec, an appropriate infrastructure enhances cycling popularity.

## 2 High quality cycling infrastructures

To experience cycling as a useful and pleasurable means of transport, cyclists frequently express infrastructural needs and preferences such as sufficient manoeuvre space, dense route network, steady cruising speed level, no sharp turns or obstacles [6–10]. Sufficient lane width is top ranked [11]. Furthermore, cyclists don't like diversions, they prefer direct routings and thus often even choose major road routes over off-road paths [12]. Although these cyclists' needs are well published, easy to understand when actually riding a bike, and transport engineers are trained in vehicular dynamics, the solutions they provide leave a lot to be desired. Fajans and Curry proposed that city administrations should buy bikes for their traffic planners' commute to experience cyclist needs from first hand [13]. Here we focus on three basic infrastructural requirements: capacity, design speed and radii and surface quality.

### 2.1 Capacity

Western capacity values usually include less than 3.5 m wide paths – real cycling highways rarely exist. We utilized density measurements from Asian roads (almost exclusively used by bikes and mopeds under slow speeds) for two-wheel capacity values of wider bicycle paths (Fig. 4). This diagram perfectly illustrates that a width of 4 m is able to cater for 5,000 to 6,000 bikes per hour.

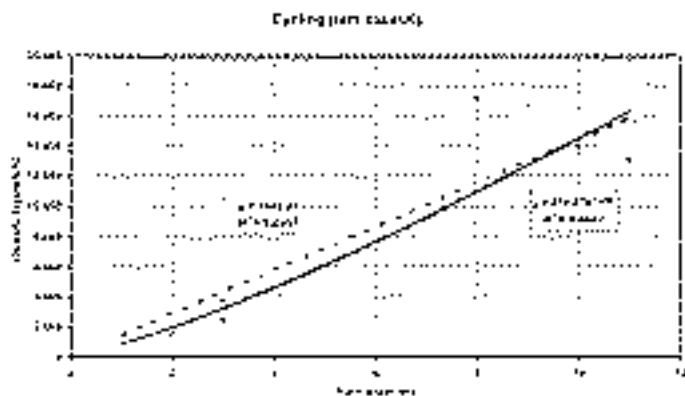

Figure 4 Bicycle path capacity, European sources and Asian measurements. Source: [14].

## 2.2 Speed and curve radii

Fig. 5 shows the radius–speed relationship for asphalt and water–bound surfaces according to selected sources. A reasonable design speed for intra–urban cycling infrastructure is 30 km/h leading to 22 m and about 38 m of inner curve radius depending on the surface.

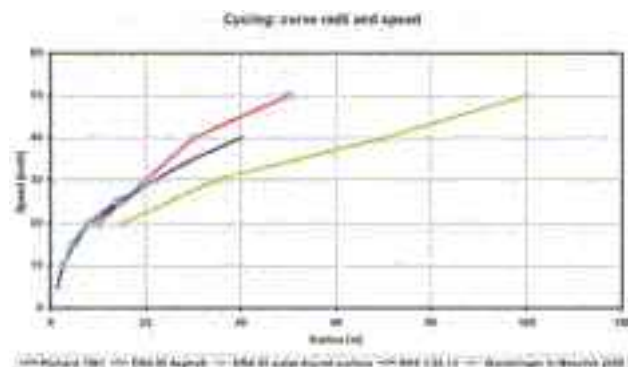

Figure 5 Speeds–curve radii relation for asphalt and water–bound surfaces. Data sources: [15–18].

## 2.3 Surface quality

Cycling is a mode of transportation closely related to body energy expenditure and it provides energy savings over pedestrians. Good surface quality is of great importance – bad quality imposes a constant stimulus on riders and thus reduces comfort and design speed remarkably. Fig. 6 shows the influence of surface quality on the rider’s energy expenditure – spanning a range of 220 %. In his survey, Utkin points out that besides the increased energy use, coarse or badly maintained surfaces superpose vibrations on cyclists that are similar to the usage of construction machinery like jackhammers. Ongoing exposure to intense vibration can cause health issues for riders. Therefore a well designed and maintained surface is necessary for premium cycling conditions [19].

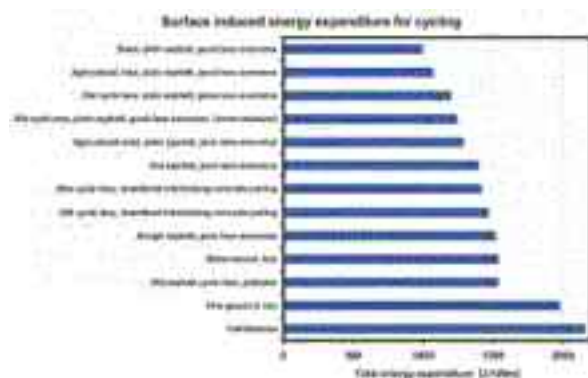

Figure 6 Surface induced energy expenditure for cycling ranging from 1,000 J for smooth asphalt to 2,200 J for a cobble stone cover. Source: [20].

### 3 The Viennese Diagonal

#### 3.1 The principle

High quality and high priority bicycle connections are frequently issued demands by cyclists – and hardly ever met with current intersection situations and changes in bike infrastructure setups.

Generally, two types of routings can be distinguished: two-sided and mono-directional vs. one-sided and bi-directional. External boundary conditions, e.g. topography or space constraints, often lead to changes from one type to the other or one side to the other along one route. At intersections, they are very often connected with 'two-step crossings' which reduce comfort due to sharp turns, little space and travel delays for cyclists (Fig. 7a).

We therefore propose the Viennese diagonal as a comfortable and viable solution for providing high quality cycling routes. The Viennese diagonal is a diagonal cycle lane alignment and aims at high priority bike routes with a large number of cyclists in comparison to normal numbers of cyclists and cars, e.g. the cycling super highways being introduced to London [21]. Such high priority bike routes may incorporate progressive signalling schemes ('green waves') and counting devices with displays as already existing in Denmark and South Tyrol. The Viennese diagonal's principle given in Fig. 7c is a well-established layout known to transport systems design, e.g. from railroads changing sides of a road (Fig. 8).

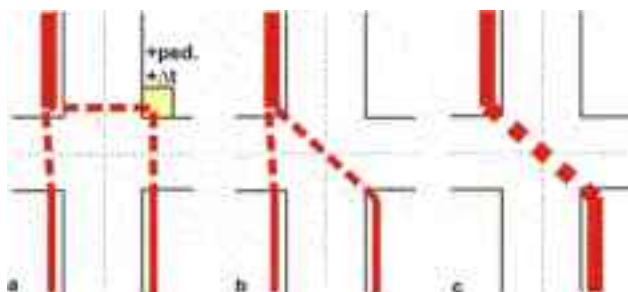

Figure 7 Intersection with regular two-step crossing (a) and two variants of the Viennese diagonal (b, c).



Figure 8 Two-track light rail changing sides of a road (Badener Bahn at LB17, Traiskirchen, Austria). Photo: T.Brezina.

### 3.2 Capacity case study

We took a standard four-way intersection with a standard two-step crossing and calculated the signalling programme and performance for a 90 seconds interval. Then we modified the intersection with a Viennese diagonal and redid the calculations (Fig. 9). With the introduction of a third phase for the Viennese diagonal, the grade of saturation increases but remains below one (Fig. 10).

To sum it up, the newly introduced bicycle infrastructure entails the following

- Benefits: It is a highly visible and present prioritization of cycling without (significant) reduction of road-flow utilizing similarities to public transport prioritization schemes;
- Challenges: It is a new concept and not yet introduced to the road code or professional's guidelines in Austria and elsewhere;
- Minor disadvantages: additional traffic light programming and roadway maintenance for on-pavement markings are necessary.



Figure 9 Diagram of two-step crossing (left) vs. diagonal layout (right).

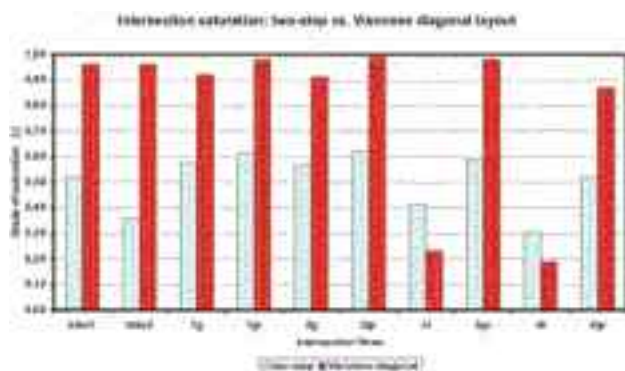

Figure 10 Diagram of intersection saturation, two-step vs. Viennese diagonal.

## 4 Conclusion

A local, high quality infrastructure is needed so cyclists can profit from their vehicular dynamics instead of being forced into pedestrian movement patterns. A dedicated cycling infrastructure needs to be optimized for cycling to tap the full potential. We introduce the Viennese diagonal as such a prioritization measure for already well used cycling routes. It is a promising idea in need of further research and pilot projects before an introduction into road traffic regulations can be considered.

## References

- [1] Molitor, R., Niegl, M., Brezina, T., Ibesich, N. & Lemmerer, H.: su:b:city (suburbia bike city) - Endbericht. 2011, pp. 59.
- [2] Winkler, A. & Oblak, S.: Masterplan Verkehr Wien 2003 - Kurzfassung. MA 18 - Stadtentwicklung und Stadtplanung. 2003, pp. 55.
- [3] Whitelegg, J.: Transport for a Sustainable Future - The Case for Europe, John Wiley & Sons, 1993.
- [4] Knoflacher, H.: Fußgeher- und Fahrradverkehr: Planungsprinzipien, Böhlau, 1995.
- [5] Schnabel, W. & Lohse, D.: Grundlagen der Straßenverkehrstechnik und der Verkehrsplanung, 2., neu bearbeitete Auflage ed, Vol. Band 2 - Verkehrsplanung, Verlag für Bauwesen, 1997.
- [6] Hagemester, C., Schmidt, A., Seidel, T. & Schlag, B.: Criteria for cyclists' everyday route choice, 3rd International Conference on Traffic and Transport Psychology, Nottingham, 2004.
- [7] Menghini, C., Carrasco, N., Schüssler, N. & Axhausen, K.W.: Route choice of cyclists in Zurich, Transportation Research Part A, 44 44, pp. 754-765, 2010.
- [8] Sener, I.N., Eluru, N. & Bhat, C.R.: An analysis of bicycle route choice preferences in Texas, us, Transportation, 36 36, pp. 511-539, 2009.
- [9] Alrutz, D., Bohle, W. & Willhaus, E.: Bewertung der Attraktivität von Radverkehrsanlagen, Berichte der Bundesanstalt für Straßenwesen - Unterreihe Verkehrstechnik, v 56. BAST. 1998, pp. 104.
- [10] Christmas, S., Helman, S., Butress, S., Newman, C. & Hutchins, R.: Cycling, Safety and Sharing the Road: Qualitative research with Cyclists and Other Road Users, Road Safety Web Publication, 17. Department for Transport. 2010, pp. 78.
- [11] Kirner Providelo, J. & de Penha Sanches, S.: Roadway and traffic characteristics for bicycling, Transportation, 38 38(5), pp. 765-777, 2011.
- [12] Aultman-Hall, L.: Commuter bicycle route choice: Analysis of major determinants and safety implications, in: Dept. of Civil Engineering, McMaster University 1996.
- [13] Fajans, J. & Curry, M.: Why Bicyclists Hate Stop Signs, Access, (18), pp. 28-31, 2001.
- [14] Niegl, M., Ibesich, N., Brezina, T., Lemmerer, H. & Molitor, R.: Integrierter Ansatz zur Erhöhung des Radverkehrsanteils im Stadt-Umland Verkehr - suburbia bike city (su:b:city), ways2community, Wien: BMVIT, 2010.
- [15] Richard, H.: Handbuch für Radverkehrsanlagen und Radverkehr, Otto Elsner Verlagsgesellschaft, 1981.
- [16] [16] FGSV: Empfehlungen für Radverkehrsanlagen - ERA 95, Forschungsgesellschaft für Straßen- und Verkehrswesen, 1995.
- [17] Meschik, M.: Planungshandbuch Radverkehr, Springer Verlag, 2008.
- [18] FSV: rvs 03.02.13: Nicht motorisierter Verkehr - Radverkehr. rvs - Richtlinien und Vorschriften für den Straßenbau, FSV - Österreichische Forschungsgemeinschaft Straße und Verkehr, 2011.
- [19] Utkin, M., Rolinski, T. & Pawlowski, P.: Surface of cyclepaths and its influence on health and safety of cyclists, Velo-city global 2010, Copenhagen: European Cyclist Federation, 2010.
- [20] Teufel, D., Bauer, P., Lippold, R. & Toczek, N.: Entwicklung und Potentiale des Fahrrad-Verkehrs, UPI-Bericht Nr. 41. Umwelt- und Prognose-Institut e.V. 2000, pp. 30.
- [21] TfL: Barclays Cycle Superhighways FAQs. Transport for London. 2011, pp. 25.





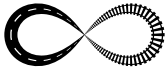

## CRITICAL PLANNING AND DESIGN PARAMETERS FOR GARAGES

**Rudolf Eger**

*University of Applied Sciences RheinMain,  
Faculty of Architecture and Civil Engineering, Wiesbaden, Germany*

### Abstract

Acceptance and usability – and thus also the economic success – of garages are based on sufficiently designed parking lots, driving/manoeuvring lanes, ramps and entrance/exit control systems. International, especially European and German design guidelines define certain measurements regarding these major garage elements.. In many cases, garages have been and are being built by applying only the minimal requirements or even less. On paper (drawings) a maximum number of lots can thus be shown by minimizing the costs. In reality, after the start of the operation, problems arise, e.g.: two lots are needed for one (bigger) vehicle which reduces the projected revenue; scratches on cars and pillars might lead to litigation; customers complain for getting wet shoes; long queues occur at entrance and/or exit. This paper discusses the necessary design vehicles, depending on the customer demand for a certain garage. Measurements for such vehicles and new statistical data (from Germany) are presented and show – as one result – that a lot for an average personal car should at least be 2,50 m wide (at 90° to lane) and lanes at least 6,00 m wide. Based on a wide range of realised garages and presenting examples, typical tasks for planning garages are being discussed: manoeuvrability of lots and lanes; best practise of column grid versus lots and lanes; headroom over lots, lanes and ramps; slope and curves of ramps; slope/folding of garage floors and queue calculation at garage entrance barriers.

*Keywords: garage, parking, design vehicle, parking lot, queue length*

### 1 Introduction

Parking facilities can be open space, one–level, on–ground sites with dedicated stripes for lots and lanes or they are garage buildings above–, on–or under– ground. Garages are often not stand–alone buildings but parking levels integrated into a building – in city centres often underground.

Demand for parking lots has lots of variables. For city centres the number of necessary parking lots depends largely on the quality of the public transport system. Many big cities – at least in Germany – restrict the realisation of new parking lots to a certain percentage if the project is well connected to public transport, thus in the inner city of Frankfurt Main/Germany you are only allowed to build 10 % of the parking lots you normally would have to build at a site outside the city.[1] Nevertheless, despite a very good and very well used public transport there usually is still a high demand of good–quality parking lots which has to be satisfied to keep residents, customers, visitors and employees staying and coming. As an example, the map of the inner city of Frankfurt Main/ Germany shows both the main pt–stations and public garages, Fig. 1.



**Figure 1** Pt-stations and garages in the city centre of Frankfurt Main/ Germany (Basic data: 11.700 public lots; i.e. 164 lots/km<sup>2</sup> built-up land; 17 lots/1.000 residents)

The following introduces some crucial criteria and tasks for a satisfying garage design.

## 2 Critical planning and design parameters

### 2.1 Vehicle design

Many older garages – but surprisingly some newly built garages too – provide lots and lanes which already cause problems if used by medium sized cars. Therefore, the first step of any planning process of a garage is to define a typical vehicle design for the actual garage project. The design vehicle for a public garage should usually be a personal car which represents 85 % of the currently running cars in the region where the garage is situated (e.g. in central Europe there is no need to consider provisions for the United States personal vehicle design, which is 5,80 m long; 2,10 m wide without mirrors); outer turning radius 7,30 m [2]). Some countries choose the 80 % and/or 90 %-percentile (e.g. Austria) to decide the size of the design vehicles. Despite widely talked-about small cars, the 85%-vehicles in Germany – and it can be assumed in other central-European countries as well – have increased in size quite considerably during the last decades. Mainly the width (+ 8 cm) and the height (+ 16 cm) have risen since 2000 (last data collection before 2010). The following table 1 shows the data for Germany [3, 4, 5, 6, 7]:

**Table 1** Development of the personal car size in Germany (85 % car)

Year	Length [m]	Width (without mirrors) [m]	Height [m]
1975 / 1991	4,70	1,75	1,50
2000 / 2005	4,74	1,76	1,51
2010 / 2011	4,77	1,84	1,67

The resulting measurements, for the 2011, of 85 % design personal cars are shown in the following figure 2 (typical cars, approximately in the frame of the mentioned percentage, are the Mercedes-C class and the vw Passat 2010).

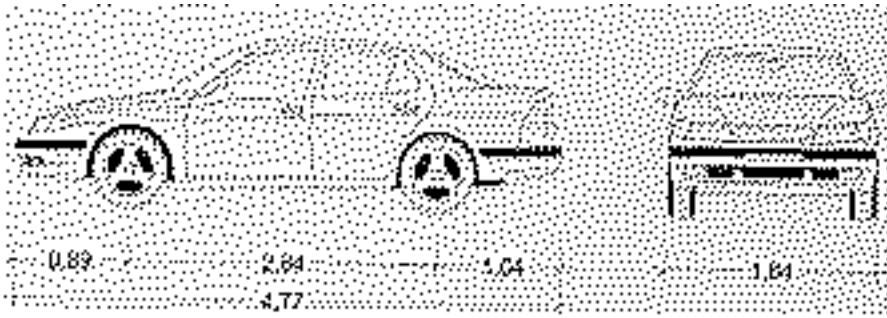

Figure 2 Design vehicle (personal car) in Germany 2010/11 (source: [7])

This car size has been derived from all new personal cars, including small and large ones, weighed with the number of registrations in the year 2010 in Germany.

Conclusion: For users with no clearly defined special needs, the design vehicle for a garage in central Europe – as an assumption based on the mentioned German data – is 1,84 m wide (without mirrors) and 4,77 m long.

For special purposes, e.g. a) garages in buildings with luxury apartments where more luxury cars and/or SUVs can be expected; b) garages or levels of garages designated for small-sized vehicles like Smart other design cars representing 85 % of a certain class should be chosen. The following Table 2 shows some of these classes:

Table 2 Special car-classes in Germany (85 % car of the class 2010/11)

Car-class	Length [m]	Width (without mirrors) [m]	Height [m]
Ultra-small (e.g. Smart)	3,64	1,65	1,56
Upper	5,20	1,95	1,49
SUV (with reeling)	5,15	1,93	2,06

## 2.2 Parking lots and lanes size

Parking lots and the adjacent area, respectively the lanes along the lots, must provide enough space to manoeuvre the above mentioned design vehicle into and out of the lot. In addition to the size of the car (width 1,84 m x length 4,77 m) there has to be enough reserves on all sides to allow a secure, comfortable and careful driving. The German guidelines for parking facilities ([6] chapter 4.2.1.6) consider 0,75 m between adjacently parked cars as comfortable and 0,55 m as acceptable for having the mirrors popped out and the door opened in an acceptable angle. At the front and the rear of a parked car  $2 \times 0,15 \text{ m} = 0,30 \text{ m}$  clearance is proposed. Together with the size of the design vehicle and assuming that all cars are parked right in the middle of the lots, the numerically deduced size of a parking lot perpendicular to the lane would be:

Length:  $0,15 \text{ m clearance} + 4,77 \text{ m car} + 0,15 \text{ m clearance} = 5,07 \text{ m}$

Width:  $0,375 \text{ m clearance} + 1,84 \text{ m car} + 0,375 \text{ m clearance} = 2,57 \text{ m}$

As cars are not always parked in the centre of the lot and drivers and passengers vary considerably in their behaviour entering and leaving the car, it can be rightly assumed that the size of a parking lot perpendicular to the lane should be:

Parking lot for 85 % design personal car: length x width = 5,00 m x 2,50 m

If upper class vehicles are chosen as a benchmark for a garage project, the proposed size – taking Table 2 under consideration and allowing more space for door–opening – should be: Parking lot for 85 % upper class car: length x width = 5,20 m x 2,70 m

If a parking lot is directly marked along a wall, additional 0,20 m should be added to the width to make it possible for most cars to move into the lot forward and not to have to turn around first and then enter the lot in reverse.

Lanes along parking lots should allow a secure slow driving along and moving into and out of the lots. To make it possible to enter a parking lot of a certain width, from a lane with a certain width, the necessary space for turning curves of cars, the column grid of the garage construction and the angle at which the lots are aligned to the lane have to be considered (see figure 3).

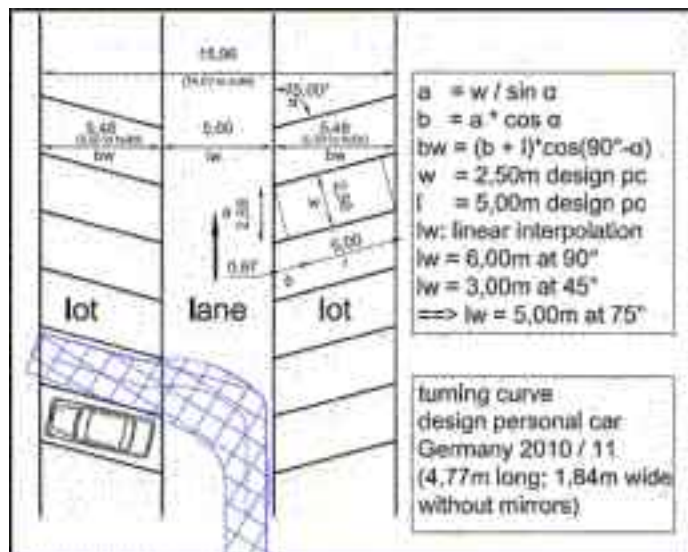

Figure 3 Geometry of parking lots and lane (example: lots at 75° angle)

Some regulations still allow lanes of 5,50 m width which is too narrow for today's car sizes. The above mentioned necessary length of a perpendicular lot is 5,07 m for the design personal car, of which 5,00 m are marked as bay, overlapping is 0,07 m into the lane.



Figure 4 Parking lots and lane with cars overlapping into the lane

If the construction system of a garage is not open spaced without columns, the necessary space for columns, walls, insulation and technical installations has to be added to the measurements of lots and lanes shown in figure 4. As many garages are underground levels of residential or office buildings, the construction grid of the building has to be adjusted with the grid of the garage. A good example is shown in figure 5 with a quadratic grid of 8,10 m which is 5 x 1,35 m, a common module in architecture.



**Figure 5** Example of a construction column grid for buildings with underground garage level(s). Realized: Opernturm garage, Frankfurt Main

### 2.3 Headroom

Sufficient headroom for a garage has to be defined properly for ramps and parking levels. At the entrance a sign has to show the allowed maximum height for a vehicle to enter (in addition a hanging girder should warn if a too high car tries to pass). The usual displayed height is currently 2,00 m. Newer data shows that the height of cars has increased considerably (see tables 1 and 2). If it is foreseeable that a garage will be used regularly by SUVs and/ or cars with roof tops, reeling's, sport facilities, the allowed height of a car to enter should be not less than 2,10 m.

As there are legally permitted tolerances between planned measures and actually realised measures (at least 0,02 m up to 0,05 m, depending on national regulations and the local construction), these tolerances should be considered. Also the actual height of a car can differ from the height printed in the car's papers (e.g. tire pressure, suspension). Therefore, as a sum of tolerances at flat garage levels at least 0,10 m should be added to the height displayed at the entrance (e.g. entrance sign 2,00 m height leads to planned headroom of 2,10 m at flat level). Along sloped ramps more headroom has to be provided: + 10 cm along the ramp (altogether 2,15 m if 2,00 m is displayed). Where the slope changes 8 % or more (e.g. from 15 % sloped ramp to 0 % flat garage level) + 20 cm at slope-changing points and 1,50 m along both sides of these points have to be considered (altogether 2,25 m if 2,00 m displayed).

Additional headroom can be necessary if the garage level is sloped for drainage (cleaning water, thawing ice and snow) and to avoid uncontrolled puddles and resulting danger of chloride impact. The necessary slope has to be at least 2 % to ensure water flowing in the right direction and having in mind the construction tolerance.

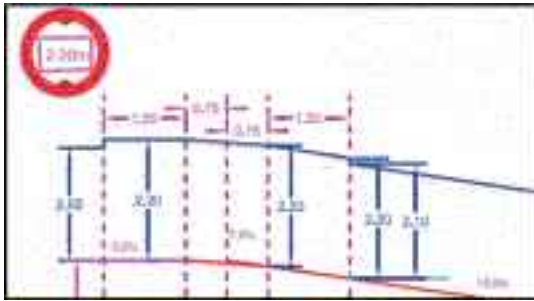

Figure 6 Example for calculating headroom along a garage ramp (5 cm construction tolerance not included!)

## 2.4 Ramps

Ramps are garage elements for changing levels upwards or downwards. For longitudinal section design a ramp should not exceed 15 % (in the middle of the respective lane) and short ramps inside a garage may be sloped up to 20 %. If the slope difference is more than  $\Delta s = 8 \%$ , a flatter section with  $\frac{1}{2} s$  for 1,5 m at the top and 2,5 m at the foot of the ramp has proved to be sufficient to avoid car damages (e.g. see figure 6: a flatter section with 7,5 % between 15 % ramp slope and 0 % garage level slope) [6].

The horizontal design of a ramp has to comply with the turning curves of the chosen design vehicle with additional clearance to allow comfortable and secure driving. Linear ramps should at least have a lane width of 2,75 m and additional clearance of 25 cm on both sides should be provided. Curved ramps must have a radius of at least 5,00 m at the inner lane boundary with at least 3,50 m lane width. Additional clearance of at least 25 cm should be provided on both sides. Some sources demand for 3,70 m lane plus 30–50 cm clearance for more comfortable driving [6], [8]. The following Figure 7 shows a spiral ramp with (nearly) minimum size: inner radius 4,75 m, outer radius 8,75 m (= lane width 3,50 m +  $2 \times 0,25$  m). This ramp serves a 4-level underground garage with 1.400 lots with no known complaints.



Figure 7 Spiral ramp 4 m in width, inner radius 4,75 m (My Zeil, Frankfurt)

## 2.5 Queue length at barriers

Entrance and exit barriers can lead to considerable queue lengths and these can disturb traffic on the adjacent street and/or the inner garage traffic flow. The German guidelines for garage facilities ([6], annex K) introduce a method to assess the queue length based on known and proven capacity of certain control devices. Summarizing and compressing the data the following figure 8 gives an impression of the expected queue length (number of personal cars, each car can be assumed to be 6 m long including distance between cars) for a known volume

of entering traffic flow. The results have proven to be quite reliable, leaning a bit to the safe side if tried with real traffic evaluations [9, 10].

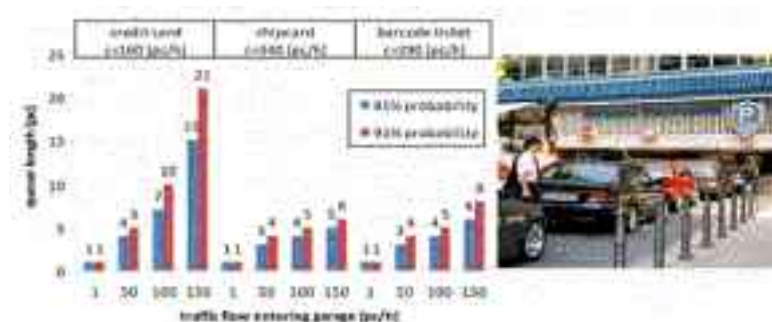

Figure 8 Queue length assumption (data from [6])

## References

- [1] Stellplatzsatzung und Stellplatzeinschränkungssatzung Frankfurt Main, 1998
- [2] AASHTO: Geometric design of highways and streets. Chapter 2, 2001
- [3] Richtlinien für Anlagen des ruhenden Verkehrs. FGSV, Köln 1975
- [4] Empfehlungen für Anlagen des ruhenden Verkehrs EAR 91. FGSV, Köln 1991
- [5] Bemessungsfahrzeuge und Schleppkurven zur Überprüfung der Befahrbarkeit von Verkehrsflächen. , Köln 2001
- [6] Empfehlungen für Anlagen des ruhenden Verkehrs EAR 05. FGSV, Köln 2005
- [7] Schuster, A., Sattler, J. & Hoffmann, S.: Neues Pkw-Bemessungsfahrzeug für den Entwurf von Anlagen des ruhenden Verkehrs, Straßenverkehrstechnik, pp. 5-10, 2012
- [8] Pech, A., Jens, K., Warmuth, G. & Zeininger, J.: Parkhäuser – Garagen. Springer Verlag, Wien, 2006
- [9] Bouhezzo, M.: Staulängen vor einer Garageneinfahrt. Thesis at Hochschule RheinMain, faculty of architecture and civil engineering, Wiesbaden 2011
- [10] Afewerki, D.: Staulängen vor Garageneinfahrten. Diploma work at Fachhochschule Wiesbaden (now: Hochschule RheinMain), faculty of civil engineering, Wiesbaden 2004





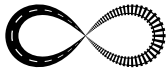

## FUTURE TRANSPORT NETWORK OF THE CITY OF DUBROVNIK

Igor Majstorović, Mario Njegovec, Ana Rigo

*University of Zagreb, Faculty of Civil Engineering, Croatia*

### Abstract

The paper presents the planned transport network of the city of Dubrovnik in the future. Being the Croatian tourist pearl Dubrovnik needs to deal with its transport problems through the contemporary transport modeling. An optimization model in solving crucial traffic problems for the functioning of the City in the future is presented. The tests of planned actions of the existing plan documentation and the introduction of new ideas are shown. The tests are based on the integral transport model of Dubrovnik. An estimation of transport effects of planned scenario for both the private transport and the public transport is elaborated. The method of evaluating planned scenarios is described. New transport solutions in the network of the city of Dubrovnik are discussed and the efficiency of the planned network is elaborated.

*Keywords: private transport, public transport, transport modeling, transport planning, transport effects, evaluation and selection of solutions*

### 1 Introduction

Tourism is the basic economic activity of Dubrovnik. 28% of its population is directly or indirectly involved in tourism. The number of tourist arrivals grows each year. In the year 2010 Dubrovnik was visited by 588.568 tourists with the total of a little bit less than 2,2 million overnight stays. Most tourists visit the City during summer months, which means that 2/3 of tourists come there in the period between June and September. Only in August 2010 there were 123.184 tourists with more than 515.000 overnight stays. Dubrovnik is one of the greatest Mediterranean destinations on the cruise market. In 2010 more than 915.000 cruise passengers visited Dubrovnik, 150.000 of them came in August only. On average in August 2010 more than 21.000 tourists a day stayed in Dubrovnik which means that the population of the city was increased by 50%. In spite of a significant increase in the number of tourists coming to Dubrovnik the transport infrastructure has not been upgraded. After the required traffic study report was made the city recognized the discrepancy between its value and the current transportation system. Therefore, an integral transport model of the current transportation system was conducted for the city of Dubrovnik. The model was used to locate the traffic problems within the existing transportation system and in the planned periods of its development. The model also served to propose different solutions the effects of which were tested.

## 2 Traffic model

The area covered by this traffic model includes the city of Dubrovnik with 32 settlements, municipality Župa dubrovačka with 16 settlements and municipality Konavle with 23 settlements (Figure 1).

For the purposes of the traffic model the area is divided into 105 zones. The city of Dubrovnik is divided into 57 zones or statistical circles while the surrounding area covers 48 zones based on the settlements. In order to define specific areas of the greatest assembling and tourist attractions within the research study we created additional zones of interest, the Dubrovnik airport, the Dubrovnik port, the center, the Old City and the County hospital. The three cordon zones are determined for the outside area representing important traffic corridors and providing transport connection between the research area and the surrounding area. All the zones are described by attributes serving for generating traffic demand (Table 1). The information used for demographic, migrational and economic attributes of the zones were obtained by the Croatian bureau of statistics, Dubrovnik tourist board and global urban plan of the Dubrovnik city.



Figure 1 Research area

Table 1 Zone attributes

Zone attributes		
number	number of citizens	high schools
code	number of employees	facilities
name	number of workplaces	allocation of space
type	tourist accommodation	

### 2.1 Model of demand

The transport model is developed as a four level transport model for the private and the public transport. The levels of the transport model are: trip generation, trip distribution, transport mode choice and transport assignment.

Trip generation was made for the following activities: home – workplace trip, home – high school trip, home – college trip, home – other places, not from home – other places, tourist

trip – accommodation and tourist trip – others, per personal groups as: active population, the employed, students, college students and tourists.

Trip attractions are workplaces, tourist accommodation, tourist attractions, school and college capacities and purpose of the areas (public, economic and mixed).

Activities and personal groups are connected by an attraction and a number of trips from one zone into another are calculated. Trip distribution was made by the gravity model and distribution matrices defining travels from one zone into another are calculated.

Trip matrices were calibrated on the basis of data obtained by traffic counts at 23 locations. The final level of transport modeling, the transport assignment was conducted for all transportation systems, i.e. car transportation, bus transportation and new metro transportation. The traffic is generated for four time terms: the base year 2011, short term from 2011 to 2016, medium term from 2016 to 2021 and long term from 2021 to 2031

Two scenarios of traffic growth, the conservative and the optimistic one, for the private transport are introduced. The growth in public transport travels is estimated to be 1% on. The growth factors for private and public transport are shown in the Table 2.

**Table 2** Growth factors for private transport

Planning period	Years growth				Public transport
	Optimistic scenario		Conservative scenario		
	1% in the narrow area of network	2% in the wider area of network	1% in the narrow area of network	1% in the wider area of network	
2011	1.04	1.08	1.04	1.08	1.04
2021	1.09	1.2	1.09	1.09	1.09
2031	1.21	1.48	1.21	1.21	1.21

The introduction of the metro lines in the year 2031 in the zone of the new transportation system reduces the number of individual travels by 15% which are then added to the public transport.

## 2.2 Model of supply

The model of supply is described by the transport network. The total network includes 1.284 nodes, 3.525 links (192 one way links) and 804 connectors.

The roads are interpreted by links and their characteristics are described by link attributes. The basic link attributes are shown in the Table 3.

**Table 3** Basic link attributes

Link attributes		
number	length	free flow speed
start node	number of lanes	longitudinal slope
end node	transport system	EWS-4 parameters
link type	capacity per direction	

In the traffic model of private transport the network is organized into freeways, state roads, county roads and local roads, and in the city area the main city roads, city roads, collector roads and the other kinds of roads as well as pedestrian roads both for the existing and the planned network. Categories, free flow speed and the length of the existing and the planned network included in the transport model are shown in the Table 4.

**Table 4** Road categories given in the transport model

Category	Length of road (km)				Free flow speed (km/h)	Capacity per road direction (vw/dm)
	City of Dubrovnik		Subs & Environs			
	existing	planned	existing	planned		
Freeway	0,00	27,84	0,00	17,32	80	15.000
State road	34,69	7,83	55,58	0,00	60	8.000
County road	10,22	0,00	55,47	0,00	50	6.000
Local road	34,45	3,70	47,71	0,00	40	4.000
Main city road	17,43	4,84	-	-	60 / 50 / 40	7.200 / 8.000
City road	38,04	10,56	-	-	50 / 40	6.400 / 4.800
Collector road	8,92	1,06	-	-	30	4.800
Other roads	88,32	7,62	-	-	30	4.800
Pedestrian	34,40	0,24	-	-	-	-
<b>Total</b>	<b>216,70</b>	<b>63,69</b>	<b>158,76</b>	<b>17,32</b>	-	-

The modeled network of the public city and suburban bus transport include all the bus lines, stops and schedules. The new transportation system of light metro is introduced and precisely routed taking into consideration the location and the height. The stops are also determined.

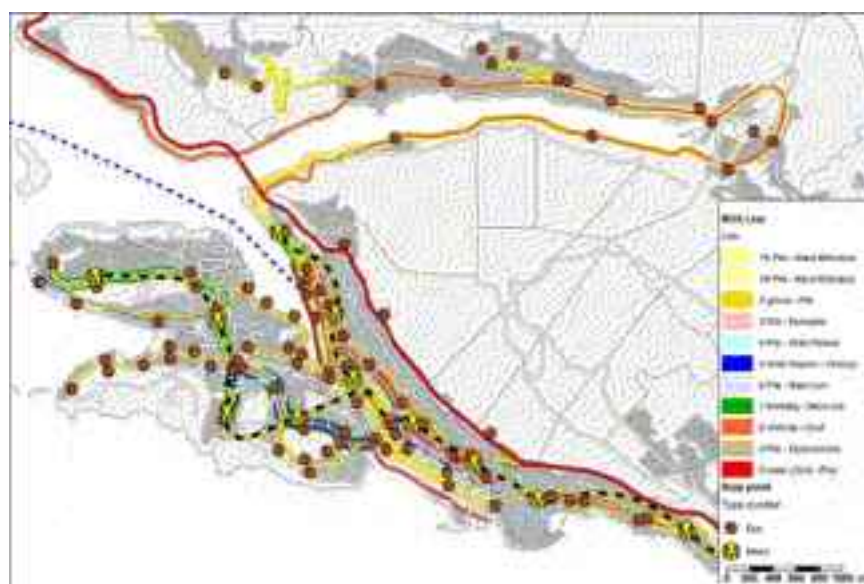

**Figure 2** Network of city bus lines and light metro with stops

The light metro network analyzed by the transport model consists of 3 routes with the following working titles: M1 Gruž port – Viktorija, M2 Viktorija – Dubrovnik airport and M3 Babin kuk – Dubrovnik City. The network of city bus and light metro lines with stops is shown in the Figure 2. The passengers would get on and off each of the public transport systems at hierarchically structured stops:

- stop point,
- stop area,
- stop area for taking another transport mode.

Stops which belong to one area of changing transport mode will exchange passengers from different transportation systems. Thus, the designed integral transport model was used for the evaluation of the existing transport system and the planned scenarios of the total transportation system of the city of Dubrovnik.

### 3 Future road network in Dubrovnik

Being at the foot of Mountain Srđ, Dubrovnik was developed along very narrow belt (up to 500 m) between the coast and the steep mountain slopes. By the end of the 1960s the Adriatic Highway D8 was built beneath Srđ slopes. Fifty years later this highway is still the only connection between Dubrovnik and the other parts of Croatia. The state road D233 to Border crossing Gornji Brgat (BH border) – Dubac connects Dubrovnik with Bosnia and Herzegovina.

Plans for the future were analyzed through 18 scenarios of the network for 4 time periods (2011, 2016, 2021 and 2031) and include connecting Dubrovnik by freeway to the state system of freeways at Osojnik in the north. In the south Dubrovnik will be connected to freeway system Župa – Plat – Čilipi at Župa junction geographically located north of Donji Brgat.

The road network of the city is connected to the external system at three locations, Sustjepan in the northwest, the Ilijina Glavica node centrally and Orsula in the east. Entering Dubrovnik when compared to the existing road system will be different by introducing the east entrance into the city at the crossroad of D8 and the Frane Supila street.

The internal road network of Dubrovnik is determined by the principle of the private and city bus transport organization as one way transportation system. One way road system can be described with 7 internal road rings:

- 1 V. Nazora – A. Starčevića – Put Republike – Splitski put,
- 2 Vukovarska – connector road Vukovarska – A. Starčevića,
- 3 tunnel 'Radeljević' – Obala S. Radića,
- 4 Od Batale – Od Svetog Mihajla,
- 5 Zagrebačka – Iza grada – tunnel 'Minčeta' – Splitski put – V. Nazora,
- 6 Tunel 'Minčeta' – Brsalje – Put branitelja – Splitski put,
- 7 P. Krešimira IV – Viktorija – F. Supila – Iza grada – Zagrebačka.

The Dubrovnik link to the system of freeways and one way road system inside the city is shown in the Figure 3.



Figure 3 City link to the system of freeways



**Figure 4** Dubrovnik City

The road ring consisting of the streets of Vladimir Nazor – Ante Starčević – Put Republike – Splitski put (under the working title 'Dubrovnik City') is the busiest part of the inner road network (Figure 4). The Dom zdravlja roundabout, intersection of the streets Put Republike, Ante Starčevića, Pera Čingrije, Branitelja Dubrovnika and Splitski put, is an integral part of the Dubrovnik City road ring and the busiest roundabout in Dubrovnik.

## 4 Evaluation

The newly proposed technical solutions of the Dubrovnik road network derived from the conceptual design to present the validity of the system. The technical solutions were tested on the basis of DOF 1:5.000, DOF 1:2.000 and a digital relief model 1:25.000. The calculation of investment value includes the price of land. The evaluation was performed for the following time periods:

- 2016 – short term period,
- 2021 – medium term period and
- 2031 – long term period.

The costs and economic indicators were calculated through the savings in the traffic system, the net present value (NPV) in the year of starting the investment, the internal rental rate (IRR) and the cost–benefit factor (C/B factor). The net present value is calculated with the discount rate of 8%. The indirect benefits were not taken into consideration. The Table 5 shows the scenarios of road transport network for particular periods with specific cost calculations and economic indicators.

Table 5 Overview of costs and economic indicators by each scenario for the private transport

Period	Scenario	New segments (* investment not included)	Investment (€)	Saving (€)	NPV (€)	B/C	IRR
2012 - 2016	S-2016_PSD_R	- Bijina glavica - 'Dubrovnik City', jednonosni sistem Nasravska - Maršićeva - Spilski put - Plo - OB - Frana Supila - N. Tesle - A. Starčevića (2 lanes)	15.563.302	1.758	-0,49	0,974	7,62%
	S-2021_PSD_R1	- Tunnel 'Mlineta' - Tunnel 'Batajjević'	17.364.039	1.417	-6,07	0,704	-
2021 - 2031	S-2031_PSD_R1	- Od Botara & Od Se. Mihajla - N. Tesle - A. Starčevića (4 lanes) - BC Ouzjeik - bridge 'Dubrovnik' * - BC Župa - Plat * - Bijina glavica - Dubac (8 lanes) - Dubac - (across) Rigat - Mikolčić detour	70.232.627	4.170	-66,95	0,475	-

The transport system for each scenario for the medium term and long term periods provides the traffic without congestion which will require certain financial sacrifices.

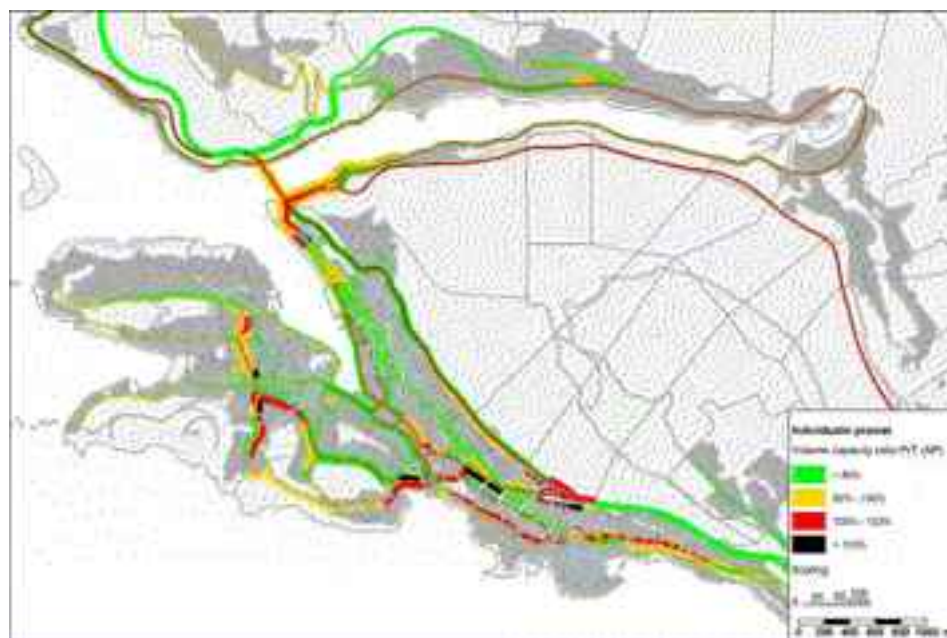

Figure 5 Saturation of planned transport network in 2031 (S-2031\_PSD\_R1)





**Figure 6** Dubrovnik City, traffic flow simulation

The evidence of the traffic without congestion of the planned Dubrovnik transport network by the year 2031 in the scenario S-2031\_PSD\_R1 is shown in the Figure 5 with the saturation of transport network.

## 5 An evidence of validity of the technical solution

Based on the planned development of road network from the scenario S-2021\_PSD\_R1 as a resultant scenario for the year 2021 traffic flow simulation (microscopic traffic model) for the Dubrovnik City area as an evidence of validity of the technical solution (Figure 6) is designed. Signalization plans for the Ilijina Glavica junction and the Dom zdravlja roundabout with traffic lights are calculated for the purpose of the simulation.

Functioning of road transportation system without congestion is indicated by a visual mark. Road indicators shown in the Table 6 demonstrate the authenticity of the proposed transport solution for the Dubrovnik city area.

**Table 6** Road indicators

		Dom zdravlja	IJA roundabout	Ilijina Glavica	Ilijina Glavica
Average Delay	s/veh	18	0	4	34
Emission CO	g/h	287	04	335	230
Emission NOx	g/h	56	16	26	43
Fuel consumption	l/h	302,60	39	342	283
LOS	-	B	A	A	B

## 6 Conclusion

The narrow coastal strip by the Adriatic Highway is completely built. There is hardly any possibility of building new infrastructure corridors in that area. Thus, planning new road corridors can be provided by the use of the underground. The plan is to build the road tunnels 'Minčeta' and 'Radeljević' by 2021 and to introduce the new public transportation system of light metro by 2031.

The problem of congestion of main road routes in Dubrovnik is solved by introducing a one way road system in the narrower area of the city by 2016. Consequently, parking lots by the roads are eliminated or a number of parking lots is reduced. Parking lots need to be substituted by new parking space away from the main roads or new garage facilities.

With the system of freeways by the year 2031 the city will be connected at Osojnik (Osojnik junction) in the north and at Donji Brgat (Župa junction) in the east regardless of potential freeway system behind Srđ. The technical procedure for finding the quality solution of the future transport network is described in 4 steps:

- 1 designing the integral transport model (macroscopic or mesoscopic) which includes all the transportation systems (pedestrian, road, bus, railway, ship, air,...),
- 2 designing the technical solutions (more versions)
- 3 evaluating the proposed technical solutions, i.e. scenarios of the future development of the transport network,
- 4 designing the microscopic transport model as an evidence of validity of proposed technical solutions.

## References

- [1] Prometna studija grada Dubrovnika, Promel projekt d.o.o. i Građevinski fakultet Sveučilišta u Zagrebu, siječanj 2011



## 16 URBAN TRANSPORT INFRASTRUCTURE





## SPEED AS AN ELEMENT FOR DESIGNING ROUNDABOUTS

Hrvoje Pilko<sup>1</sup>, Davor Brčić<sup>1</sup>, Nikola Šubić<sup>2</sup>

*1 University of Zagreb Faculty of Transport and Traffic Sciences, Croatia*

*2 HOK Insurance d.d. Zagreb, Croatia*

### Abstract

The increasing construction and implementation of roundabouts in the last 20 years is a result of a need for capacity increment, as well as the safety level increment on road intersections at-grade. Designing and shaping roundabouts, especially in urban areas, represents a complicated problem with a number of different conditioned elements that need to be satisfied. Geometrical elements such as the dimension of the outer roundabout diameter and number and width of the lanes considerably affect the trajectory of the vehicle's path through the intersection, respectively the vehicle speed that has an immediate effect on the safety and the capacity of the roundabout. Through a depiction of four existing roundabouts in the City of Zagreb, this paper will analyze the speed as an important roundabout designing factor. The research results will provide guidelines for roundabout designers, considering that the design speed is in correlation with the measured actual vehicle speed on a roundabout.

*Keywords: roundabouts in urban areas, modelling and designing, vehicle movement trajectory vehicle speed*

### 1 Introduction

Modelling and designing roundabouts with small diameters ( $D_v \leq 35\text{m}$ ) in urban areas, presents a complicated task where a series of conditioned elements must be satisfied. Geometrical elements such as the inscribed circle radius and the number and width of the approaching lanes considerably affect the shape of vehicle movement trajectory through the intersection, i.e. the speed of the vehicles that has direct impact on the roundabout safety and capacity. A well-designed roundabout reduces the relative speeds between conflicting traffic streams by requiring vehicles to negotiate the roundabout along a curved path. Therefore, the ability to predict the vehicular speeds through the roundabout in the preliminary design is an important element while designing and modelling roundabouts. This paper will show an analysis of four roundabouts in the City of Zagreb, as well as the predicted speed on the roundabout entrance, circulatory roadway and exit in relation with the actual measured speeds of the analyzed intersections.

### 2 The speed on the vehicle path through roundabout

#### 2.1 Design speed

Achieving the adequate speed throughout the roundabout results in accident possibility decrement, and also in intersection capacity increment. With the increment of the trajectory curve, the speed between the vehicles entering the circulatory roadway decreases as well as the speed of the vehicles already in the roundabout. Thus, the number of traffic accidents that happen while entering or exiting the circulatory roadway considerably decrease. However, on

roundabouts with multilane roundabouts (on circular roadways and approach legs) increasing vehicle path curvature creates greater side friction between adjacent traffic. This could result in traffic accident increment caused by the interlacing of vehicles or their overrunning the roadway [6]. Therefore, with the goal of decreasing traffic accidents for every roundabout type an optimum design speed is suggested (Figure 1) [6].

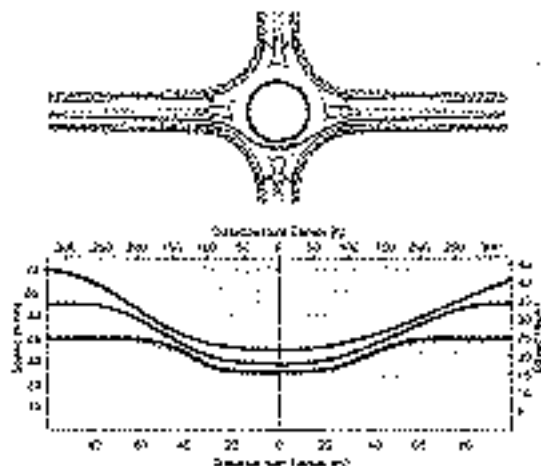

Figure 1 Depiction of the design speed values for a single-lane roundabout [6]

Table 1 shows maximum recommended values of the design speed for a vehicle entering a roundabout.

Table 1 Maximum recommended design speed for a vehicle entering a roundabout [2, 6]

Roundabout type	Maximum recommended design speed at the roundabout entrance [km/h]
Mini roundabout (RKT <sub>m</sub> )	25 [km/h]
Small, single-lane <sup>(1)</sup> roundabout (RKT <sub>w</sub> )	35 [km/h]
Small, double-lane <sup>(2)</sup> roundabout (RKT <sub>M</sub> )	40 [km/h]
Medium, single-lane (RKTSV)	40 [km/h]
Medium, double-lane (RKTSV.2)	50 [km/h]

Calculating the design speed is based on the radii of the vehicle path as shown:

$$V = \sqrt{127R(e + f)} \quad (1)$$

where: V = design speed [km/h], R = radius [m], e = superelevation rate [m/m], f = side friction factor [6].

Adherence between the pneumatic and the roadway is important for the stability and the safety of the vehicle movement through the roundabout, i.e. for the safer negotiation of the vehicle path. Superelevation values are usually assumed to be +0.02 for entry and exit curves and -0.02 for curves around the central island. Values of the side friction factor depend on the vehicle speed, the roadway type and the condition of the roadway (Figure 2.).

The design speed shouldn't differ considerably from the actual roundabout speed, and should be in correlation with other design parameters, respectively with the presumed traffic environment [4, 6].

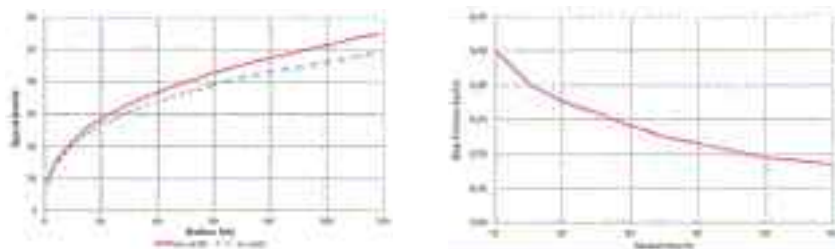

a) vehicle speed and diameter relation      b) side friction factor and vehicle speed relation

**Figure 2** Relation depiction; a) diameter of the vehicle path and vehicle speed b) vehicle speed and side friction factor [6]

## 2.2 Vehicle path through the roundabout

For determining the speed on the roundabout, it is necessary to determine the fastest vehicle path allowed by the geometry (the trajectory that allows the maximum vehicle speed through the roundabout). While determining the vehicle path it is assumed that there is no other traffic or marked traffic lanes. Therefore, the vehicle can move freely through the approach leg, the approach entrance, around the central island, and towards the exit. It can be noticed that every vehicle path is characterized by three radii: the entry path radius, circulating path radius and the exit path radius. It is assumed that the vehicle is 2 m wide, and that it will maintain a minimum clearance of 0.5 m from a roadway centerline or concrete curb and the drawn edge of the splitter island. Therefore, the centerline of the vehicle path is 1.5 m away from a roadway centerline, 1.5 m away from the concrete curb and 1.0 m away from the drawn line of the splitter island (Figure 3.) [4, 6].

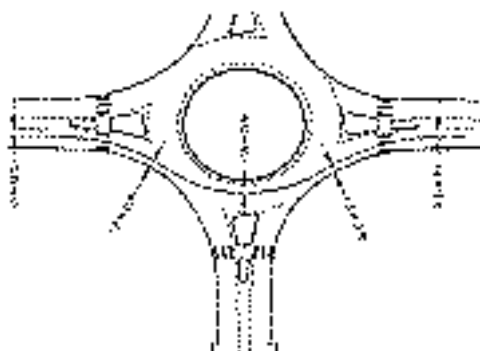

**Figure 3** Layout of the fastest vehicle path through a roundabout [6].

The fastest vehicle path for the drive through manoeuvre is a series of reverse curves (to the trajectory on the right a trajectory on the left continues, and then a right trajectory again takes place). In cases with no central island the vehicle path will be straight. Therefore, the radius of reverse curve depends on the smallest radius that usually appears while the vehicle turns around the central island. For all the approaches it is necessary to sketch the fastest vehicle paths, which can be done by using the AutoCAD tool [1, 4, 5, 6].



## 2.3 Vehicle path radii on roundabouts

With the goal of achieving an adequate design speed for the fastest vehicle path it is necessary to check the consistency/permanence for all movements. Speed consistency results in a higher level of traffic safety by decreasing the speed difference among conflicting traffic flows. Also, it simplifies the task of merging into the conflicting traffic stream, minimizing critical gaps, thus optimizing entry capacity. Therefore, for each approach it is necessary to check five critical radii:  $R_1$  – entry path radius;  $R_2$  – circulating path radius;  $R_3$  – exit path radius;  $R_4$  – left-turn path radius;  $R_5$  – right-turn path radius (Figure 4.). It is necessary to note that the values of these radii are not equal to the presumed curb radii [4, 6].

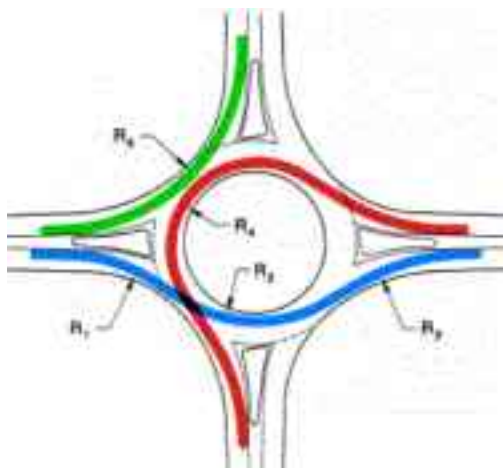

Figure 4 Vehicle path radii [6]

It is desirable that on the fastest vehicle path,  $R_1$  is smaller than  $R_2$ , which on the other hand needs to be smaller than  $R_3$ . This ensures that speeds will be reduced to their lowest level at the roundabout entry and will thereby reduce the likelihood of loss-of-control crashes. In cases where the  $R_1 < R_2$  condition is not possible to satisfy, then it is necessary that  $R_1$  is greater than  $R_2$  provided the relative difference in speeds is less than 20 km/h. At mini and small roundabouts with higher intensity of pedestrian traffic, and with the goal of maximizing exit speeds, it is desirable that the exiting radii are equal or inconsiderably greater than  $R_2$ . By checking the values of the radius  $R_4$  the condition that maximum speed difference between the entrance flow and the circulatory roadway flow is smaller than 20km/h is assured. The design speed for the  $R_5$  radius should be the same as the maximum design speed of the whole roundabout and not higher than 20km/h from the design speed of the  $R_4$  radius, which has a conflict point with the  $R_2$  [4, 6].

## 3 Analysis of the research results

The analysis of the speed on the vehicle movement trajectory in the conditions of a normal flow has been conducted on four single-lane roundabouts with four single-lane approaches, situated in central and periphery part of Zagreb. Design parameters of the observed roundabouts are shown in Table 2. Because of the design characteristics of the chosen roundabouts and analyzed traffic flow movements, speed on the vehicle path through a roundabout from every leg approach has been analyzed. The vehicle speed at the entrance ( $V_1$ ), in the roundabout ( $V_2$ ) and at the roundabout exit ( $V_3$ ) was measured, as well as the corresponding radii ( $R_1$ ,

$R_2$  and  $R_3$ ). Speed on right turns ( $V_4$ ) and left turns ( $V_5$ ) through the roundabout, respectively the radii ( $R_4$  and  $R_5$ ) because of previously mentioned reasons are not the research topic. Measurements of the approaching vehicle speed were done in cooperation with The Ministry of the Interior on the 07.07.2008., Tuesday, in morning peak-hours, in intervals of 5, 10 and 15 minutes. Meteorological conditions were appropriate, it was mostly sunny with slight clouds which allowed good visibility on all intersections, and the roadway was dry. In accordance with the specifics of analyzed intersections, and needed information on the traffic flow speed and technical characteristics of the instrument a MULTANOVA 6F instrument was chosen and used. During measurements a police automobile without police markings was used along with an officer in a civil uniform, in order to reduce the possibility of spotting the police, which could affect the driver reactions [1, 5]. Measurements of the approaching speed, the speed in the circulatory roadway, and the speed at the roundabout exit were done on the 15.09.2011., Thursday, in the morning peak-hours, in intervals of 15 minutes with a GPS installed in a personal vehicle. Also, meteorological conditions were appropriate, sunny weather enabled good visibility on all intersections, and the roadway was dry.

**Table 2** Design elements of chosen roundabouts [1, 5]

No. of roundabout	Type	Location	Approach layout				Driveway				Superelevation	
			$D_v$ [m]	$D_u$ [m]	$t_k$ [m]	$q$ [%]	$b_p$ [m]	$r_1$ [m]	$r_2$ [m]	$r_3$ [m]		$r_4$ [m]
1	Roundabout	...	...	...	...	...	...	...	...	...	...	...
2	Roundabout	...	...	...	...	...	...	...	...	...	...	...
3	Roundabout	...	...	...	...	...	...	...	...	...	...	...
4	Roundabout	...	...	...	...	...	...	...	...	...	...	...
5	Roundabout	...	...	...	...	...	...	...	...	...	...	...

Depiction:  $D_v$  – outer roundabout diameter [m],  $D_u$  – inner roundabout diameter [m],  $t_k$  – circular roadway width [m],  $q$  - superelevation rate on circular roadway gradient [ $\pm\%$ ],  $b_p$  – approach leg width [m].

Table 3 shows data acquired with speed measurements for vehicle movement trajectories through the roundabout. The design speed of the roundabout was calculated in accordance with the formula (1) with the help of measured radii in the layouts [4, 5, 6], while on the specimen of 50 measurements the average measured vehicle speed was depicted, as well as the deviating values.

**Table 3** Design speed and average measured vehicle speed on chosen intersections

No. of roundabout	Location	Approach layout			Driveway			Superelevation		
		$D_v$ [m]	$D_u$ [m]	$t_k$ [m]	$r_1$ [m]	$r_2$ [m]	$r_3$ [m]	$r_4$ [m]	$q$ [%]	$b_p$ [m]
1	...	...	...	...	...	...	...	...	...	...
2	...	...	...	...	...	...	...	...	...	...
3	...	...	...	...	...	...	...	...	...	...
4	...	...	...	...	...	...	...	...	...	...
5	...	...	...	...	...	...	...	...	...	...

For comparison of acquired results, speed on the vehicle path through the roundabout is shown in the following graphs.

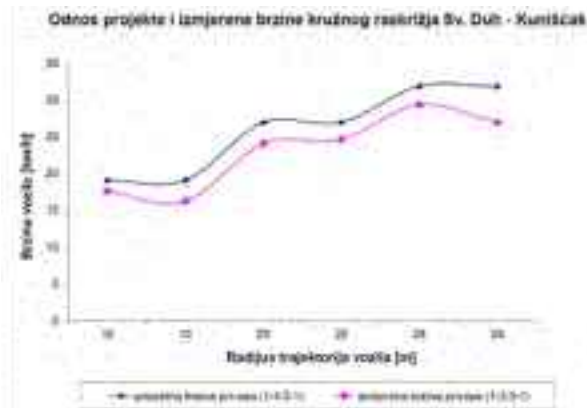

Figure 5 The relationship of the design speed and the measured speed in the roundabout Sv. Duh–Kunišćak



Figure 6 The relationship of the design speed and the measured speed in the roundabout Petrova–Jordanovac



Figure 7 The relationship of the design speed and the measured speed in the roundabout Voćarska–Bijenička

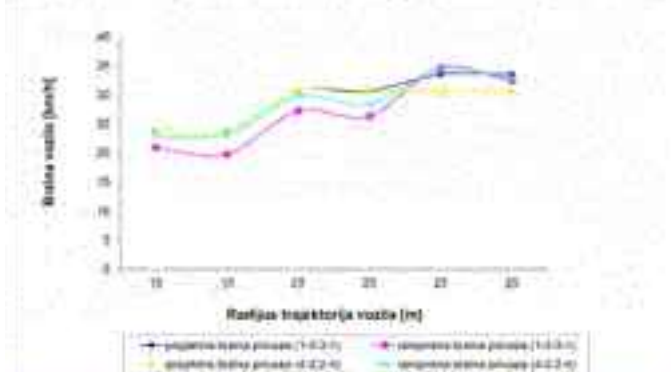

**Figure 8** The relationship of the design speed and the measured speed in the roundabout Radnička–Petruševac

On the Figures 5, 6, 7 and 8 the relationship between the measured vehicle speeds is shown, respectively from every approach. The diagrams show that the conditions  $R_1, R_2 < R_3$  have been satisfied while designing the roundabout. Respectively, the lowest measured speed is the one on the vehicle path around the central island, while the highest speeds are measured at the roundabout exit.

Research results also show that average values of measured speed at the entrance are smaller than 35 km/h, and are in accordance with the recommendations from Table 2. However, on certain intersections deviations of measured individual speeds from the design speed were noted (Table 3.). On the Sv. Duh–Kuniščak intersection the average measured speed from the approach leg 3 to the approach leg 1 was 15.50% smaller than the design speed. On the Petrova–Jordanovac intersection the average measured speed from the approach 3 to the approach 1 had a 21.11% smaller value than the design speed, while the actual speed from the approach 2 to the approach 4 was 4.46% higher than the design speed. On the Voćarska–Bijenička intersection the measured speed from the approach 1 to the approach 3 was lower than the design speed for 10.23%, while the same speed was 16.97% higher than the design speed for the movement from the approach 4 to the approach leg 2. On the Radnička–Petruševac intersection the average measured speed from the approach 3 to the approach 1 was 16.65% smaller than the design speed, while for the movement from the approach 4 to the approach 2 the speed difference was 12.21% (actual speed was higher than the design speed). These deviations are a result of specific spatial locations of mentioned roundabouts, their design elements and characteristics of traffic flow during the measurements.

## 4 Conclusion

Designing and dimensioning of roundabouts with small diameters in urban areas ( $D_v \leq 35$  m) presents a complex problem where it is necessary to determine a series of elements out of which the size of the inner and outer diameter of the roundabout, the number and width of approaching legs are of most importance. The mentioned elements considerably affect the vehicle path through the roundabout, i.e. the speed of the vehicles that has direct impact on the roundabout safety and capacity [1, 4, 5, 6].

The research on the vehicle path speed in normal conditions was conducted on four single-lane roundabouts with four single-lane approaches in the City of Zagreb. The research results showed that the basic design condition  $R_1, R_2 < R_3$  was satisfied. Looking at traffic intersections, deviations between the design and actual speed are spanning from -21.11% to +16.69%, and are the result of the location and function of the intersection in the road network, design elements and characteristics of traffic flow as well as driver conduct during the measurements.

It should be pointed out, that in the Republic of Croatia there is no existing legislative regulative for roundabout design. In the existing guidelines 'Smjernice za projektiranje raskrižja u naseljima sa stajališta sigurnosti prometa' [7] conditions/rules for determining the design speed are not defined. Therefore, guidelines 'Roundabouts; An Informational Guide, 2000, Federal Highway Administration'[6] can serve the designers while designing the roundabout speed, which the conducted research confirms.

The conducted research on the vehicle path speed should serve as a basis for future thorough and systematic research of the causality of speed and vehicle path on roundabouts. The research should comprise a larger number of roundabouts with a bigger number of test samples, and the speed for left and right turns through the roundabout. Furthermore, it would be necessary to bring into connection the effect of the design speed with the level of safety on the existing roundabouts, analyzing traffic accident by types and samples.

## References

- [1] Korekcija oblikovnosti i sigurnosti u raskrižjima s kružnim tokom prometa (voditelj prof. dr. sc. Ivan Legac), Fakultet prometnih znanosti, Sveučilište u Zagrebu, Zagreb, 2008-2011.
- [2] Legac, I., i dr.: Gradske prometnice, Fakultet prometnih znanosti, Sveučilište u Zagrebu, Zagreb, 2011.
- [3] Legac, I., Pilko, H., Šubić, N.: Introduction of Roundabouts in Croatia – preliminary experiences, Proceedings on 16th IRF World Congress, Lisabon, Portugal, 25 – 28 svibnja 2010.
- [4] Mehmood, A: Geometric design of single-lane roundabouts for optimum consistency and operation, Ryerson University Toronto, Ontario, Canada, SAD, 2003.
- [5] Prometna analiza i unapređenje sigurnosti i protočnosti raskrižja s kružnim tokom prometa (studija), Fakultet prometnih znanosti, Sveučilište u Zagrebu, Zagreb, listopad 2009.
- [6] Roundabouts: An Informational Guide, Publication No. FHWA-RD-00-067, Kittelson & Associates, Inc., Portland, Oregon, SAD, lipanj 2000.
- [7] Smjernice za projektiranje raskrižja u naseljima sa stajališta sigurnosti prometa (prijedlog), Fakultet prometnih znanosti Sveučilišta u Zagrebu, Zagreb, siječanj 2004.



## DEVELOPMENT OF METRO ZAGREB PROJECT

Davorin Kolić

*Infranumerika doo, Croatia*

### Abstract

One city as Zagreb needs a massive transport public system that answers to daily public traffic commuting. First ideas about development of one metro system started more than 20 years ago. In the meantime first steps have been performed in direction of development in the future: traffic study has been finished in the year 2000 and first comparative studies for some type of metro system have been finished in 2006. Evaluation of minimal required alignments leading to the metro network and types of required structures have been evaluated and presented. Overall cost estimation and comparison of variant has been presented and prepared for future discussions.

*Keywords: massive public transport, metro system, light rail, underground structures*

### 1 Introduction

The first technically argued views on building metro in the City of Zagreb were put forward 25 years ago [1]. The traffic demands were clearly articulated and its growth accurately forecasted as witnessed by the situation, in which we have found ourselves today: ever increasing traffic congestion, chronic lack of parking spaces, growing noise and air pollution within the urban area, large masses of people within the historic centre moving day by day in the north–south and east–west direction. Construction funding was based on the financial model normally practiced at that time (the loans taken by the city or the state government).

Today there is a broad variety of ways and means to fund urban public transport projects, the recent trend being a change from direct financing by a local owner (city, state) to involvement of private sector funding, which makes the problem of finding financial sources for construction of urban underground railway more easier to solve. The initial reactions to the article in the technical literature [2] have indicated that there exists a body of experts acutely aware of the problem and ready to share their views. Through subsequent discussion the terms used for urban transport modes were agreed upon and their characteristics specified. The term metro was used as equivalent for urban underground railways, the other urban transport modes being considered were suburban railways (light rail systems), tram based systems and bus systems. Particular attention has been given to tramways and their comparison with bus based systems, the constraints of each mode of public transport being pointed out. The detailed explanations given may be subsequently used when trying to justify the application of the metro system in the specific traffic environment of the city of Zagreb. On such basis, and supported by the enthusiasm of the engineering community a preliminary meeting of an informal group was organized 20 years after that, or more exactly on April 4, 1994, in the year marking 900th anniversary of the City of Zagreb, to review the ideas concerning the project of the working title 'Zagreb–Metro' [3]. The meeting was attended by 10 participants who, based on the working material, reviewed current awareness, demands and possibilities of the urban community, and exchanged information on the ongoing studies, plans and priorities prevailing in the city. The suggested material deals with the most visible transportation problems of the city, pointing to the solutions applied in other cities, particularly those concerning metro systems.

The idea of the first ring line of the future metro was presented along with the comparison of the traffic conditions in Zagreb with those in other cities of the similar size, geologic conditions and traffic demands. The length of the line was about 12 km, the distance between the stations from 0,5–1,5 km encompassing the inner city core on the side of Donji grad (Lower Town) and the four areas of Novi Zagreb (New Zagreb): Velesajam, Siget, Sopot and Središće. One of the most important guidelines of the meeting was the information on existence of the transportation planning study of the city of Zagreb, which at that time was at the first stage of preparation to be subsequently further elaborated [4].

## 2 Traffic demands and flows

Status–quo analysis presented in the study characterized the traffic in the city of Zagreb as follows:

- 214 private cars per 1000 inhabitants in the city of 930.000 inhabitants (excluding wider city area), i.e. about 200.000 private cars in the city;
- chronic lack of parking spaces;
- intensive daily traffic through the inner city core;
- absence of bicycle traffic (not surprising due to the absence of separate bicycle paths, and the private car traffic being so intense making bicycling very dangerous exercise);
- high degree of air pollution by exhaust gases from motor vehicles (the absence of monitoring stations for measurement of air pollution degree);
- exceptionally high noise load (the absence of detailed measurements);
- great number of traffic accidents.

The study was prepared in collaboration with one of the leading consulting companies dealing with traffic issues having head offices in Germany (Aachen/Munich). The guidelines proposed for improving traffic conditions in the city clearly illustrate the methods and means used for solving such problems in Central European cities:

- encourage use of nonmotorized modes of transportation;
- increase traffic safety;
- car–free city centre (Donji grad) (applies to all vehicles, aside from public transport, taxis, emergency–and public utility services);
- ensure safety of pedestrian movements in the car–free city centre;
- drastic lowering of pollution by exhaust gases from private cars and measurement of air pollution degree: CO<sub>2</sub>, NO<sub>x</sub>, SO<sub>2</sub>, O<sub>3</sub>;
- drastic lowering of traffic induced noise in the city centre.



Figure 1 Natural and transport barriers in the wider Zagreb area

Further parts of the study comprise the analyses of various traffic concepts, investigating better use of existing traffic modes and corridors. The topic of metro was mentioned in one sentence only, not being further elaborated, probably due to unfamiliarity with such transport mode, as well as the absence of tradition of construction of underground spaces in soft ground and lack of experience of our investors, designers and contractors in tunnelling in urban environment. In any case, that particular study had decisive influence on traffic-related ideas to be elaborated in preparing proposal of the metro system presented in this work.

The city of Zagreb is spread longitudinally in the east-west direction, the natural and transport barriers in the city area being of the same direction: the Medvednica Mountain, the main railway line passing through Glavni kolodvor (Main Railway Station), the motorway running north of the Sava River (Ljubljanska Avenue), the flow of the Sava River, the southern railway passing through the Zagreb railway freight yard and finally the Zagreb bypass road.

Traffic flow process in the city is characterized by the intensive traffic in the east-west direction, but also in the north-south direction connecting Novi Zagreb with Donji grad. The traffic flow is intensive also over the roads linking outer suburbs and satellite towns Velika Gorica, Sesvete, Samobor, Zaprešić and Podsused with the inner city core. Following such relations the alignments of the first metro lines were set down, having underground, at grade and elevated sections.



**Figure 2** Final variant of the proposed Zagreb metro alignment network

The first stage, representing the first section of the proposed first line will be a link of two areas located on the north-south tangent line from Donji grad to Novi Zagreb, and extension of this line further south to the Pleso Airport and the satellite town of Velika Gorica. The southern part of the line to the Sava River would run at grade to cross the Sava River over the bridge after which it would continue underground. The underground section would follow Draškovićeva street up to one of the future underground junctions: Trg hrvatskih velikana. The second stage of the development would comprise closed ring line running from Trg žrtava fašizma across main city square (Ban Jelačić Square) and further across Trešnjevka to the new areas such as Jarun, crossing the Sava River again to reach Dubrovačka Avenue in Novi Zagreb, and proceeding further to TE-TO (thermal power plant), from where it would return back to the city centre and the junction at Trg hrvatskih velikana. This line strengthens the link of the central part of Donji grad with new suburbs, linking at the same time the historic city centre with regional centres in new suburbs, thus strengthening the regional traffic south of the Sava River. [5,6].



### 3 Geological setting

Providing, the plan view arrangement of metro lines proves to be acceptable, the question remains at what depth to locate the underground system, so as to make the construction process cost effective and safe for execution, and future operation efficient. Looking at the geological longitudinal profiles we could see that the basin below the Medvednica Mountain covering Donji grad area, Sava river bed, and Novi Zagreb plain consists of layers of sand, gravel, sandy and silty gravels or gravelly clay. The groundwater levels are typically at about 2–3 meters below ground level, and the layers of clay are located at about 8–12 m below ground level [7]. The geological longitudinal profiles considered during analysis are located along the north–south direction and crossing the city across three directions: Trešnjevka–Sava–Remetinec–Botinec; Donji grad–Sava–Velesajam–Klara–Mala Mlaka; D. Bukovec–Maksimir–Sava–Zaprude–Hrelič–Buzin, Fig. 3.

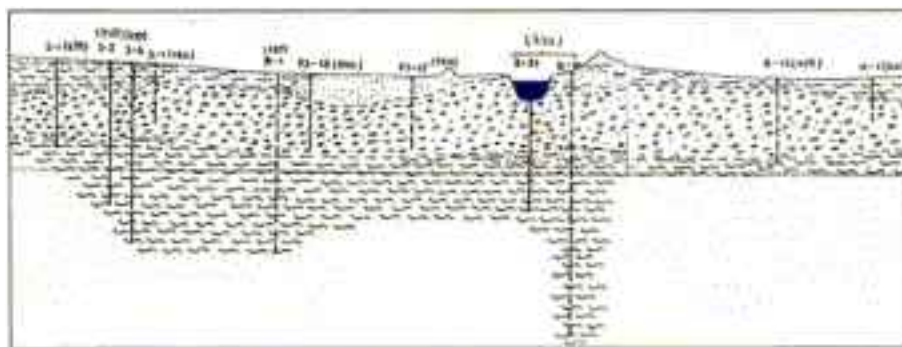

Figure 3 Geological longitudinal profile at the location of the new bridge.

Taking into account the experiences of other metro systems in the cities lying on the plains along the rivers (Munich, Budapest, Vienna), it would be to advantage to lower the longitudinal axis of the underground line to a depth of 15–20 m under the ground into the layer of clay. Such location has several advantages and represents the best solution, for the following reasons:

Simpler construction of the line being driven through mostly uniform sediments of a single geological formation, the cohesivity of clay being to advantage when tunnelling by either conventional method (NATM = New Austrian Tunnelling Method), or by using TBM, or by compressed air method.

Tunnelling in clay strata has an advantage as the clay layers, on account of their lower permeability, act as a sort of barrier to ingress of water, thus reducing substantially dewatering costs and increasing safety of tunnelling works, regardless of the excavation method applied.

### 4 Technology of construction of metro structures

If we consider the technology of construction of underground and aboveground structures as parts of the metro system, we could apply the methods used in the Central Europe under similar conditions, e.g. those in Munich, Vienna and Budapest [8–14]. The stations of the said metro systems are located at a depth of about 15–20 m (rail top level at the station platform), those in Budapest being located somewhat deeper: in the range of 20–35 m. These depths make it still possible to build the stations from the ground level. That method of building underground station developed in the last thirty years consists of first constructing the diaphragm walls (nowadays, pile walls are used more often), followed by excavation of a building pit to a depth of several meters, the roof slab is then constructed, upon completion of which the

ground is subsequently back-filled and the traffic reinstated. Following that all the works on station construction are carried out underground under the protection of the roof slab. This method is known under the name of top-down method, or in German speaking countries as Schlitzwand-Deckelbauweise, Fig. 4. It is a cost effective and appropriate solution for construction of stations in urban environment, in soft soils with problems of water ingress.

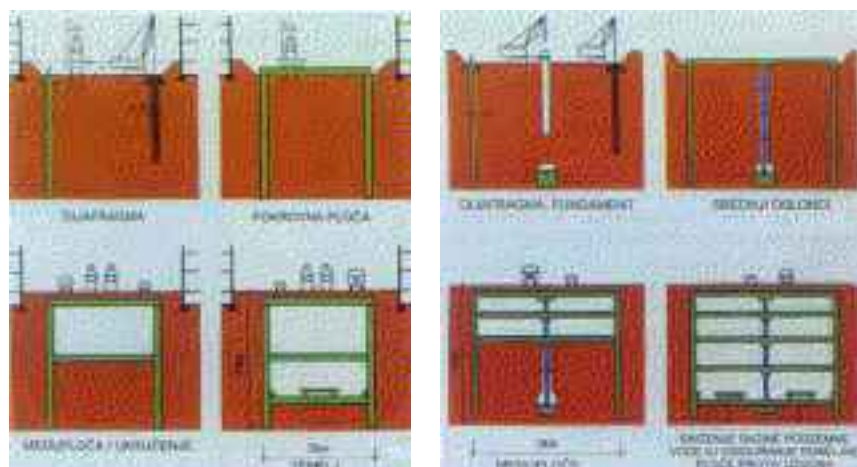

**Figure 4** Construction of metro stations by Top-Down method (case of Munich subway) : construction of diaphragm with roof slab (left) and with roof slab and central column (right).



**Figure 5** Excavation methods-conventional: top left- single sidewall drift;bottom left- twin sidewall drift, TBM technology (example from Paris metro)

The excavation of tunnel between adjacent stations is carried out by conventional methods or by using tunnel boring machines (TBM). The most often conventional method used is the New Austrian Tunneling Method (NATM) known in Germany under the name of Spritzbetonbauweise. Its application in soft soils in the city of Munich differs in regard to geological formations: tertiary sediments (marl, clay) or quaternary sediments (sands, gravels). NATM was applied most of all on account of being cost effective considering that each metro section from station to station represented separate tender lot during procurement process. As the distances between stations in the city are relatively small, 0.4-1.5 km, NATM was in most cases superior to other methods due to its flexibility in regard to geology variation and smaller initial costs. Application of tunnel boring machines (TBM) is nowadays considered as a common tunnelling method with provided economic justification. By rough estimate, tunnelling by TBM techno-

logy is cost effective for the tunnel lengths over 2 km, regardless of the diameter. In other cases, TBM is applied in soft soils when the measures needed for soil stabilization are of such extent that the application of TBM is more advantageous in regard to safety and cost or results in smaller settlement of ground surface. Some cities, e.g. Budapest, divided procurement of construction works for new Budapest Metro Line 4 into several lots: for bored tunnels of 8.0 km length, and separately for the stations.

Of course, all the lines, or sections of the line, of the metro system need not be run underground, at least not in the first stage of construction. The first line of 'Zagreb–Metro' is planned with surface sections too including crossing of Sava River, and for that purpose a conceptual solution of a new bridge is prepared located on the extension of Draškovićeve street [15]. The cabled–stayed bridge option was selected with single pylon and stay cables in inclined symmetrical arrangement as the economically most feasible solution for the designed loads of road, railway and pedestrian traffic which the new city bridge of central location should bear, [15].

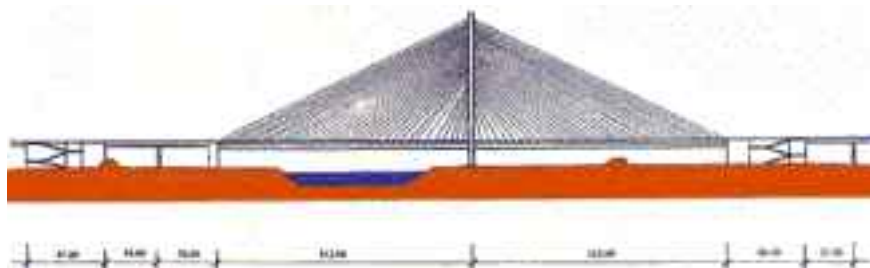

Figure 6 New bridge across Sava River

## 5 Economical factors and system development dynamics

Looking at current representative costs on tunnel markets in urban environment in Central Europe, the total capital costs per route–meter including stations (and excluding equipment and ventilation) lie mainly between EUR 17.500–25.000 (2006 prices). These costs should be adjusted in accordance with respective labour cost on home market, but also in accordance with real productivity of that labour. This analysis shows that any cost estimate is site and country specific as regards ground conditions, environmental and safety constraints, labour costs, etc. However, such a complex venture could hardly be carried out without collaboration with foreign contractors, because it requires specific experience and expertise which is built over the years working on concrete projects. As the time schedule is concerned, it takes in average 12–14 years to develop a single metro line, which broken down into stages gives as follows:

- elaboration of variants 4 years; year 1–4
- design preparation 8 years; year 5–13
- line construction 5 years; year 8–13
- line equipment 4 years; year 9–13

## References

- [1] Brezarić, V.: Metro u Zagrebu, Građevinar 25 (1973) 5, str. 162.-165.
- [2] Žagar, Z.: Metro u Zagrebu – za ili protiv, Građevinar 26 (1974) 3, str. 84.-88.
- [3] Hudec, M.; Kolić, D.: Zagreb zaslužuje bolju prometnu budućnost (podloga pripremljena za inicijativni sastanak o projektu 'Metro Zagreb', održanom u Zagrebu 20. travnja, 1994., str.1-23, neobjavljeno
- [4] Ploss, G.; Boesefeldt, J.; Hösch, M.; Poloski, D.; Korlaet, Ž.: Verkehrsentwicklungsplan Zagreb – Phase I.: Projektplanung, s. 1-70, Građevinski fakultet Sveučilišta u Zagrebu, Juli, 1993.
- [5] Blennemann F.: Effects of Urban Rapid Transport System Construction, Tunnel 2/1989., pp. 70.-80.
- [6] Planung der Tunnel für die Fern-, S- und U-Bahn in der Mitte Berlins, TIS 1/ 1994, s. 30.-32.
- [7] Magdalenić, A.; Jurak, H.: Seizmička mikrorajonizacija grada Zagreba – Geološki profili, Geološki zavod, Zagreb 1968
- [8] Greschik, G.: Budapest's Metro – Past and Present, Tunnels & Tunneling International, Nov. 1997., pp. 30.-32.
- [9] Gulyas, L.: General Information on the Metro Line 4, Section I (Kelenföldi pu. – Keleti pu.)- Technical Solutions and Main Features of the New Metro Line Section, 1999., pp. 1.-20.
- [10] \*\*\*\*\* : Die 1. Und 2. Ausbauphase der Wiener U-Bahn, 1969- 1983, Compress Verlag, Wien, 1985.
- [11] \*\*\*\*\* : Die U-Bahn Linie U3, 1981-1997, Compress Verlag, Wien, 1991.
- [12] Hochmuth, w. und and.:U-Bahn für München : U-Bahn-Linie 8/1, 1980.
- [13] Hochmuth, W.und and.: 25 Jahre U-Bahn –Bau in München, 1990.
- [14] Hackelsberger, C.: U-Bahn Architektur in München, Prestel-Verlag, München, 1997.
- [15] Kolić D., Gulyas L., Irshad M. :'Structural and Economical Parameters of Feasibility of Light Rail Zagreb System', Symposium 'Traffic Problematics in Zagreb City', HAZU Croatian Academy of Sciences and Arts, Zagreb, Croatia, June 12-13, 2006, pp.535-542
- [16] Kozary, I. et al.: The Budapest Metro, Uvaterv Technical Publications 1976/2, 1976., pp. 1.-110.





## MINI–ROUNDBABOUTS IN URBAN AREAS

Sanja Šurdonja, Sergije Babić, Aleksandra Deluka–Tibljaš, Marijana Cuculić  
*University of Rijeka Faculty of Civil Engineering, Croatia*

### Abstract

Today's urban space offers little possible traffic solutions of the intersections, especially when it comes to city centres. Possible solutions, which do not require great area, are mini–roundabouts. They are characterized by a transit central island, around which passenger vehicles (and other small sizes vehicles) operate as in other roundabouts, while long vehicles (buses, trucks, etc.) operate as in classic intersections at level, crossing fully or partly over the central island. This type of roundabouts is usually carried out in populated areas, as a measure traffic calming or as a solution to increase the capacity of existing classic intersection or intersection with traffic lights. Many studies have shown that the application of this type of intersection has significantly increased the capacity of the intersection and reduced the number of traffic accidents. Traffic calming and relatively low construction costs are considered to be a significant positive feature of these intersections. However, in case of application of mini–roundabouts as traffic calming measures it is necessary to be careful because a roundabout without a raised central island may be poorly visible for drivers of passenger cars and thus may increase the risk of accidents. In such cases, special attention should be given to street lighting and other elements to calm traffic at the approach to the intersection. In the case of a large number of pedestrians and cyclists, mini–roundabouts are poorer solutions compared to classic intersections because at classic intersections their crossing is usually protected by traffic lights.

This paper will compare the guidelines for the performance of mini–roundabouts of other states, because the Croatian guidelines do not deal with this type of intersection, even though there are many mini–roundabouts already exist in Croatia.

*Keywords: mini–roundabout, guidelines, urban area, design, costs*

### 1 Introduction

Mini–roundabouts are subtypes of roundabouts, but deserve to be viewed as a chapter for itself because of the special features associated with the design, implementation and capacity of these intersections. For this reason, in the guidelines of many countries, these intersections have a separate chapter.

Although one might expect that from these types of roundabouts other roundabouts were developed, the fact is that these intersections developed more recently and still are quite unexplored. The first mini–roundabout appeared in USA, in early 20th century. Vehicles were circling in one direction around the central pillar which was called 'dummy cop'. Sometime later, those mini–roundabouts (primarily those with a minimum diameter of 10m) were made with a small central island, in the form of a dome or fungi. Connecticut State first started with the performance of mini–roundabouts. At the beginning, those intersections were made without a raised central island. Those islands were drawn in white colour. The first such intersection, made by the engineer Eno, had a 'target' in the middle, which consisted of a white circle with a diameter of 60cm and 2 concentric circles 30cm width on the mutual distance of 30cm, so the diameter

in whole was 3m. This was the beginning of mini-roundabouts, which are used all over England even today [1].

In the United Kingdom mini roundabouts were developed in the 1960s and 1970s. The yield-on-entry rule was widely tested and proven over the period from 1962 to 1966. Roundabouts could become smaller because they were no longer locked up. Tests in 1971 showed that large roundabout layouts didn't work well even with the yield rule. Further tests on smaller three-arm roundabouts proved that the mini-roundabout with its nominal central island would work at appropriate sites and would yield much higher capacity than equivalent traffic signals [2].

The period between the 1966 and 1974 in England, was the time of extensive research on the roundabouts with small and very small diameter of central islands and on roundabouts without a raised central island. Small expenses enabled verification of many ideas and requirements for their performance and use. It is interesting to mention that in England all studies during that time, were performed at the 'real' roundabouts, not at polygons, or using computer simulation, in a real environment! During this period of extensive analysis another, less known form of roundabouts appeared (double mini-roundabouts, 'split minis', 'multiple minis', 'hollow minis', 'ring systems'). Only recently they started to gain their meaning and application [3].

Since the beginning of the introduction of mini-roundabouts in England, three extensive and comprehensive analysis of traffic safety were performed on those roundabouts (in 1974, 1980. and 1993.), which included almost all previously built mini-roundabouts. The last one (1993) covered the 85% of all mini-roundabouts, of which 95% were three-arms. The main conclusions of this analysis were as follows [3]:

- mini (and 'normal') roundabouts had a lower level of accidents than other types of roundabouts,
- multiarm mini-roundabouts had the largest number accidents, in which one participant was a pedestrian,
- number of car accidents (vehicle-vehicle) was increased with decreasing the radius of the mini roundabout,
- no accident has occurred at a U-turn ('U' manoeuvre),
- at the traffic load of 15.000–25.000 veh/day, the level of traffic accidents in a mini-roundabout amounted to 2.5 accident/year, and at the 'normal' roundabout 1.5 accident/year.

Prof. Werner Brilon research group (from Ruhr Universitat Bochum, Germany), conducted a study on 18 intersections in the centres of major cities or in their suburbs (residential areas), which were reconstructed in four years in the mini-roundabouts. Traffic volumes on these intersections were from 2.000 to 17.000 veh/day. Those intersections were selected for the mini roundabouts reconstruction because of the low level of traffic safety, high speeds of vehicles, high conflict area, long waiting time from the minor directions [4].

The results of the German study show that traffic volume of 15,000 vehicles/day for a mini-roundabout does not represent any problem. In especially good conditions (the traffic load is evenly distributed on all approaches, and the percentage of left-turning vehicles is very small), those intersections can handle the traffic load of up to 20,000 vehicles/day [4].

The study results confirmed that the mini-roundabouts in the German residential areas are not only a better solution than classic intersections, but also better than common (small and medium) roundabouts. It was also concluded that for the German conditions mini-roundabout is a much cheaper solution than reconstruction in a new classic intersection [4].

The first mini-roundabout in Croatia was built in Zagreb in 2002. After that, a double mini-roundabout was built on the island of Rab in 2003 and that was the beginning of small and mini-roundabouts in Zagreb and Istria, especially in Poreč. The first prefabricated mini-roundabout was built in 2006 near Opatija, which has already, in the first summer season after the performance (with a very low-cost performance), confirmed the expected increase in capacity and reduced speeds at the intersection [5].

The goal of this paper is to present basic strategies for design of mini-roundabouts applied in UK, USA, Switzerland and Germany.

## 2 Brief summary of guidelines of different countries

### 2.1 UK guidelines

UK guidelines define design elements for mini-roundabouts, give instructions about the safety, about road users specific requirements, about the assessment, and about the conspicuity.

Mini-roundabouts must only be used on roads with a speed limit of 50km/h or less and where the 85th percentile dry weather speed of traffic is less than 60km/h within a distance of 70 metres from the proposed give way line on all approaches, unless installed in combination with speed reduction measures.

Mini-roundabouts must not be used:

- at new junctions;
- at direct accesses;
- on dual carriageways;
- at a junction where the forecast traffic flow on any arm is below 500 vehicles per day (2-way AADT).
- at or near junctions where turns into or out from side roads are prohibited, because drivers do not expect to see vehicles U-turning on mini-roundabouts;
- if there is five or more arms.

Careful consideration is required where significant numbers of pedestrian crossing movements are likely to take place across any of the arms of a mini-roundabout. The safety of cyclists and motorcyclists must be considered when choosing, siting and designing a mini-roundabout. They should not be used at sites where inexperienced riders are likely to use them (on routes to schools for example) except in conjunction with adequate speed reduction measures [6].



**Figure 1** Mini-roundabout with a transit central island [7]

The maximum inscribed circle diameter (ICD) of a mini-roundabout is 28m. Above this dimension, a normal roundabout can accommodate the largest design vehicle and must be used. The white circle (in the centre of a mini-roundabout) must be as large as practicable (diameter 1m–4m), positioned using the inside of the swept path of cars. Vehicle proceeding through the junction must keep to the left of the white circle, unless the size of the vehicle or the layout of the junction makes it impracticable to do so (Fig. 1.). Therefore, the white circle must be sized and located so that drivers of light vehicles are not encouraged to drive on it or pass on the wrong side of it when negotiating the junction. The white circle should be formed and in white reflectorised materials. It may be domed to a recommended maximum height at the cen-



tre of 100mm (125mm, but not recommended) for a four-metre diameter marking. No other road markings than the prescribed mini-roundabout markings are permitted. A concentric overrun area (maximum diameter is 7.5m) may be used if required to increase the deflection and conspicuity. Overrun areas may be sloped up to the white circle at an angle of up to 15°. Traffic islands may be provided to separate opposing streams of traffic and to assist provision of adequate deflection of the path of vehicles approaching the mini-roundabout. They can increase conspicuity to drivers approaching the mini-roundabout and also provide location for pedestrian crossing. A kerbed splitter island must be provided where, without it, vehicles would encounter an easier path if they were to pass on the wrong side of the white circle. The entry lane width is 3–4m, except at a two lane approach where the minimum lane widths can be reduced to 2.5m. [6]

Local authority consultation suggests the range £10,000–£30,000 for 3-arm or £15,000–£50,000 for 4-arm single mini-roundabouts (at 2003 outturn prices) [8].

## 2.2 U.S. guidelines

The U.S. guidelines define a mini-roundabout as a type of intersection that can be used at physically-constrained locations in place of stop-controlled or signalized intersections to help improve safety problems and reduce excessive delays at minor approaches.

A mini-roundabout can often be developed to fit within the existing right-of-way constraints, and generally it is not recommended for intersections with more than four arms. In some cases there may be adequate spacing between arms to allow for two closely-spaced mini-roundabouts. Mini-roundabouts do not provide explicit priority to specific users such as trains, transit, or emergency vehicles. They are less suited for roadways with speeds exceeding 30 to 35 mph (50 to 55 km/h).

A number of these factors may preclude the installation of a mini-roundabout:

- high volumes of trucks;
- locations in which U-turn truck traffic is expected;
- locations with light volumes of minor street traffic.

Mini-roundabouts are generally recommended for intersections in which the total entering daily traffic volume is no more than approximately 15,000 vehicles. Multilane mini-roundabouts have been used in the U.K. but are rare elsewhere.

A mini-roundabout inscribed circle diameter generally should not exceed 90 ft (30 m). Above 90 ft (30 m), the inscribed circle diameter is typically large enough to accommodate the design vehicles navigating around a raised central island.

The central island is typically fully traversable and may either be domed or raised with a mountable curb and flat top for larger islands. The central island should be domed using 5 to 6% cross slope, with a maximum height of 5 in (12 cm).

Raised islands are preferred over flush islands. A non-traversable island is used if all design vehicles can navigate the roundabout without tracking over the splitter island area, if there is sufficient space available to provide an island with a minimum area of 50 ft<sup>2</sup> (4.6 m<sup>2</sup>) and if there are pedestrians present at the intersection with regular frequency (Fig. 2.). A traversable island is used if some design vehicles must travel over the splitter island area and truck volumes are minor, and if there is sufficient space available to provide an island with a minimum area of 50 ft<sup>2</sup> (4.6 m<sup>2</sup>). A flush island is used if vehicles are expected to travel over the splitter island area with relative frequency to navigate the intersection, an island with a minimum area of 50 ft<sup>2</sup> (4.6 m<sup>2</sup>) cannot be achieved and the approach has low vehicle speeds (preferably no more than 25 mph [40 km/h]) [9].

Costs range from about \$50,000 for an installation consisting entirely of pavement markings and signage to \$250,000 or more for mini-roundabouts that include raised islands and pedestrian improvements [9].

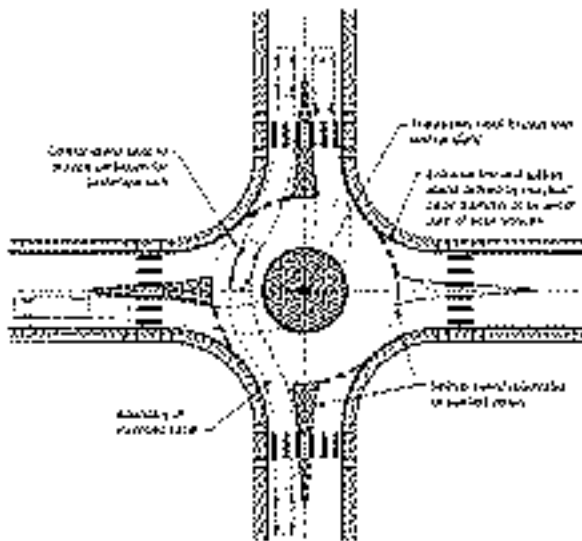

Figure 2 Design features of a mini-roundabout [9]

### 2.3 Swiss guidelines

Swiss guidelines recommend the use of mini-roundabouts on the roads in urban areas, while only exceptionally on roads outside populated areas, if it is not possible to apply other types of roundabouts or other intersections. Mini roundabouts should not be built:

- if it is not possible to apply the minimum design elements;
- when in a certain area a small roundabout (not mini!) can be build;
- when the daily traffic load exceeds 15.000 veh/day, or when the sum of the traffic load at the entrance and in the circle is more than 1200 veh/hour;
- where pedestrian traffic is especially dense.

The minimum outside diameter of these roundabouts is 14 to 26m. Mini-roundabouts with transit central island have a minimum diameter of 14m, while the mini-roundabouts with partially transit central island, must have a minimum diameter of 18m. The centre of the roundabout should be located at the intersection of all arm axis. Arrangement of arms should prevent passing without turning. Entrance angle should be selected so as to prevent tangent entry into the roundabout. The minimum angle between the two arms must be at least 30 degrees.[10]

### 2.4 German guidelines

German guidelines recommend a diameter between 13m and 24m for mini-roundabouts. Larger vehicles can override the central island as far as their swept pat. As a result of the investigations the following rules are recommended for application [11,12]:

- application only in urban areas (maximum allowed speed = 50 km/h);
- inscribed circle diameter between 13 and 24 m;
- circular roadway width between 4,5 and 6 m;
- cross slope 2,5 % inclined to the outside;
- central island with a maximum height of 12 cm (in the centre) above the circular lane.
- capacity up to a maximum of 20.000 veh/day;
- no flaring of the entries;
- only single lane entries and exits.



**Figure 3** Mini-Roundabout in Hamburg [13]

Experiments with rural mini-roundabouts have also been performed. As a result, mini-roundabouts are not further recommended outside built up areas due to safety concerns [13].

### 3 Conclusion

Mini-roundabouts in some countries are present for decades, which enabled their detailed research. The results of these studies have greatly contributed to the development of guidelines for the design of this type of roundabouts. UK guidelines stand out as a particularly detailed one. Apart from suggesting sites where the use of mini-roundabouts is favorable, they provide detailed guidelines on the safety, about road users specific requirements, about the assessment, about the geometric design features, and about the conspicuity. U.S. guidelines have taken over a large part of U.K. guidelines, although in some parts they are applying their own experiences (e.g. avoiding only flashed central islands because they believe that traversable raised central islands are more visible).

Regarding the main design elements, nearly all guidelines are similar: maximum inscribed diameter is recommended by the U.S. guidelines (up to 30m), while the German guidelines recommend up to 24m. Regarding the speed on these intersections, all the guidelines point out 50–55 km/h as a maximum speed. Marking a mini-roundabout (horizontal and vertical) is different from country to country, but all have in common timely identification and notification such as intersections for all road users.

The capacity of these intersections is poorly covered in all guidelines: UK guidelines suggest the use of software to calculate the capacity, the U.S. provide information on maximum daily load of the intersection in which this type of intersection is applicable, while this area is slightly more elaborated in the paper of Werner Brilon [13].

Recently, mini-roundabouts began to appear in Croatia, but in the absence of experience and guidelines, designers often reach for the guidelines of countries, where the tradition of mini-roundabouts is present for several decades. Such a great experience, which of course included a number of mistakes in the beginning of design of these intersections, is a precondition for the development of quality guidelines. However, 'copying' of guidelines of other countries does not ensure a quality design of mini-roundabouts in Croatia. Driving culture in some countries and the presence of a large number of other types of roundabouts are a precondition for the proper functioning of mini-roundabouts. Given the above, it is necessary to ask yourself whether such requirements exist in our county and at which level.

## References

- [1] Brown, M.: The Design of Roundabouts,TRL, HMSO, 1995.
- [2] Sawers, C.: Mini-Roundabouts for the United States, ITE Journal, pp. 46-50, 2009.
- [3] Tollazzi, T., Sawers, C.: Mini kružna čvorišta – iskustva nekih država i mogućnost primjene u našoj sredini; *Suvremeni promet Hrvatskog znanstvenog društva za promet*; 3-4, pp. 205-209, 2001.
- [4] Tollazzi, T., Lanović, Z.: Njemačka pilotska studija o mini kružnim raskrižjima i prvi predlagani primjeri u našem prostoru; *Suvremeni promet Hrvatskog znanstvenog društva za promet*; 5, pp. 359-364, 2002.
- [5] Benigar, M., Tollazzi, T.: Nova kružna raskrižja - mini, mala i montažna – optimalna rješenja u urbanism sredinama, *Drugi Internacionalni naučno-stručni skup Građevinarstvo – nauka i praksa, Žabljak*, pp.637-642, 2008.
- [6] Design manual for roads and bridges, Volume 6: Road Geometry, Section 2: Junctions, Part 2 TD 54/07, *Design of Mini-Roundabouts*, London, 2007.
- [7] Chris's British Road Directory, <http://www.cbrd.co.uk>
- [8] Department for Transport and the County Surveyors Society. *Mini Roundabouts, Good Practice Guidance*. Department for Transport, United Kingdom, November 27, 2006.
- [9] FHWA. *Mini-Roundabout, Technical Summary.*, 2010.
- [10] Schweizer Norm 640 263, *Vereinigung Schweizerischer Strassenfachleute, Knoten*, pp. 14-15, Zurich, 2000.
- [11] NRW, *Empfehlungen zum Einsatz und zur Gestaltung von Mini Kreisverkehrsplaetzen. (Recommendations for the application and design of mini roundabouts)*, Ministry for Economy, Energy, and Transportation of the state of Northrhine Westphalia (NRW), 1999
- [12] FGSV, *Merkblatt für die Anlage von Kreisverkehrsplätzen. Forschungsgesellschaft für Strassen und Verkehrswesen*, FGSV, Köln, 2006
- [13] Brilon, W.: *Studies on Roundabouts in Germany: Lessons Learned*. Paper presented at the 3rd International TRB-Roundabout Conference, Carmel, Indiana, May 2011



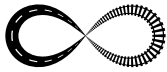

## DESIGN ELEMENTS OF MODERN ROUNDABOUTS

Mario Njegovec, Željko Stepan, Ana Rigo

*University of Zagreb, Faculty of Civil Engineering, Croatia*

### Abstract

Roundabouts are used in the transportation system all around the world. Design elements of German, Swiss and Austrian guidelines are analyzed in the paper. Different approaches in determining design elements and their differences and similarities are discussed. The advantages of roundabouts when compared to conventional intersections are based on the appropriate geometric design. Based on implemented and designed roundabouts in the county of Varaždin a comparison to the guidelines is shown. Options in geometry optimization for increasing the efficiency of the analyzed roundabouts are also presented.

*Keywords: roundabouts, geometric design, intersection planning*

### 1 Introduction

Today modern roundabouts are the most attractive kind of intersections in many countries. They are characterized by the improved safety, time saving and road capacity.

The modern roundabout was developed in the United Kingdom in the 1960s by introducing a rule of that required entering traffic to give way to circulating traffic. This changed the design and the analysis of intersection capacity. Traditional roundabouts where circulating traffic yields the right of way to any entering vehicles are designed with a large diameter which provides more longer circular segments for path overlap, and stopping in the circulating lane causes a total congestion in the intersection. The new rule provides the reduced size of a roundabout with equal road capacity, increased traffic safety and the prevention of the congestion at the very intersection.

Positive experiences with modern single-lane roundabouts contributed to further research and development of other types of roundabouts. Substantial practical experiences initiated the formation of guides for designing such roundabouts. The recent achievements in this field for Germany [1], Austria [2], Switzerland [3] and the United States of America [4] are shown in the Table 1. Geometric design is crucial for appropriate operation of roundabouts in terms of the safety and the road capacity.

**Table 1** Overview of the guides

Country	Guides	Year
Germany	Merkblatt für die Anlage von Kreisverkehren	2006
Austria	Plangleiche Knoten-Kreisverkehr – RVS 03.05.14	2010
Switzerland	Schweizer Norm SN 640 263	1999
USA	NCHRP: REPORT 672, Roundabouts: An Informational Guide, 2nd Ed.	2011

## 2 Achievements in different countries

### 2.1 General

The basic principle of the geometric design is to induce the desirable vehicular speeds resulting in improved intersection safety. Types of roundabouts are defined by spatial limitation, location and traffic capacity (Table 2).

Mini-roundabouts are a type of roundabout characterized by a small external diameter and traversable central island for large vehicles. They are commonly used in urban environments with average operating speeds of 50 km/h or less.

Single-lane roundabouts represent a standard solution and they are characterized by single entry lane, exist lane and circulatory lane. There is a non-traversable central island and they are used both in urban and rural environments. Their geometric design typically includes raised splitter islands.

Multi-lane roundabouts have two or more entry and exit lanes which means that more vehicles can travel side by side in circulatory lane. Due to a possibility of path overlap at the entry and the exit as well as higher speeds these multi-lane roundabouts are less safe in comparison with single-lane roundabouts.

**Table 2** Types of roundabouts

	Germany (D)	Austria (A)	Switzerland (CH)	United States of America (USA)
Types of roundabouts	Mini	Mini	Mini	Mini
	Small single lane	Single lane	Single lane	Single lane
	Small with two lane curculatory lane	Multi lane		Multi lane
	Big with traffic lights			

### 2.2 German guides

Mini-roundabouts have a diameter of 13 m to 22 m and the road capacity of 18000 veh/day. A central island is traversable and has truck apron raised by 4 cm–5 cm, and 12 cm maximum in the center. The width of circulatory lane is between 4 m and 6 m with transversal inclination of 2.5% outwards. The entry and exit radius is from 8 m to 10 m.

Small single-lane roundabouts have the road capacity of 25000 veh/day. The external diameter is from 26 m to 45 m, the entry radius is from 10 m to 16 m and the exit radius is from 12 m to 18 m. These dimensions provide great traffic safety. Smaller radii are used in urban environments. Distance of transit traffic around the central island should not be less than double widths of approach lane. Circulatory lane being 6.5 m–9 m wide consists of driving and traversable part used by large vehicles.

Small double-lane roundabouts have one or two lane entry with the entry radii of 12 m–16 m, depending on the traffic load and one lane exit with the exit radii of 12 m–18 m. In the circulating area there are two traffic lanes with the total width of 8 m–10 m, but they are not marked with the horizontal signalization. Diameter varies from 40 m to 60 m with the maximum road capacity of 32000 vehicles a day.



**Figure 1** Types of roundabouts in German guides

Light signalization is used at big roundabouts. Their diameter is more than 60 m and they have two or more lanes in entry, exit and circulatory lanes.

According to the German guides the designing of small double-lane roundabouts is not allowed due to the reduced safety. The solution of the problem of increased through traffic is found in the use of roundabouts with the spiral traffic course, the so called 'turbo roundabouts'. This type of a roundabout was developed in the Netherlands and it provides the safety characteristics of a single-lane rotary with the capacity increased up to 30% in comparison with a double-lane roundabout. The idea of the turbo roundabouts is based on lane change maneuver prior to entering the intersection and on the spiral traffic course to the desired exit. The entry is perpendicular to the circulatory lane. Lanes are separated by spiral horizontal signalization and physically splitted by small cambers. A number of conflict points is reduced from 16 to 10 when compared to classical double-lane roundabouts [5] and [6]. Several such roundabouts, with certain modifications, are built all over Germany. Lanes are separated only by road surface marking. The guides for such roundabouts are expected to be issued. The concept of turbo roundabout is shown in the Figure 2.

### 2.3 Austrian guides

Table 3 shows the main characteristics of roundabouts with the basic geometric design elements. The geometric elements in mini-roundabouts are determined on the basis of curve of the course of design vehicles. It is recommended that single-lane roundabouts have the external diameter of 35 m to 40 m and that multi-lane roundabouts have the external diameter of 50 m to 60 m.



**Figure 2** Basic concept of turbo roundabout and its design in the Netherlands and Germany



**Table 3** Design elements of roundabouts in Austria

	Mini roundabouts	Single-lane roundabouts	Multi-lane roundabouts
Environment	urban	urban or rural	urban or rural
External diameter	< 26 m	≥ 26 m	≥ 40 m
Circulatory lane	single lane	single lane	multi lane
Entry lane	single lane	single lane	single or multi lane
Exit lane	single lane	single lane	single or multi lane
Central island	traversable	non-traversable	non-traversable
Entry radius	–	10–14 m (12–16 m)	10–14 m (12–16 m)
Exit radius	–	12–16 m (15–25 m)	12–16 m (15–25 m)
Circulatory lane width	–	6.5–9.0 m	8–10 m
Maximum capacity	10000 veh/day	25000 veh/day	30000 veh/day

## 2.4 Swiss guides

Mini roundabouts and single-lane roundabouts are designed with the entry radii of 10 m to 12 m, while the approach radius is five times larger. In a properly designed entry the entry angle  $\alpha$  has to be as large as possible. The exit radius is from 12 m to 14 m. Small roundabouts with circulatory lane width of 7–8 m are characterized by external diameter of 14–16 m. Single-lane roundabouts have external diameter of 26–40 m. The deflection angle of  $\beta > 45^\circ$  has to be reached for achieving the necessary deflection.

The Figure 3 left shows the design elements of Swiss roundabouts. Appropriate operation at low entry and circulatory lane speeds by defining the entry/exit radius is regulated by the entry angle (Figure 3 right) and the deflection angle.

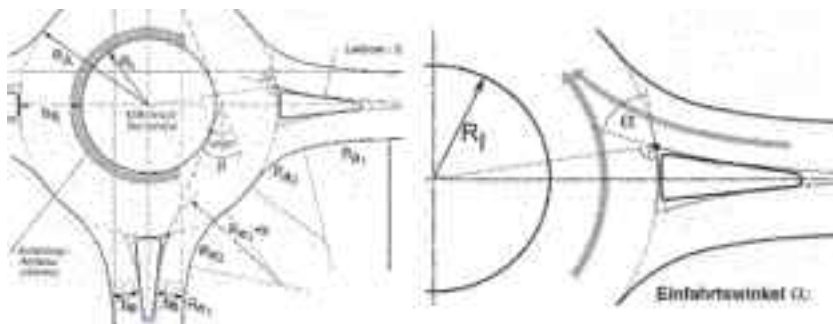

**Figure 3** Design elements and entry angle at Swiss roundabouts

## 2.5 USA guides

All the geometric components are interrelated in order to provide basic features of roundabouts, i.e. safety and road capacity. In the design of the intersection characteristics have to be tested through the fastest path for all the directions.

The Table 4 shows the basic design characteristics and the Figure 5 shows types of roundabouts according to the American guides.

**Table 4** Basic design characteristics

Design elements	Mini roundabouts	Single-lane roundabouts	Multi-lane roundabouts
Desirable maximum entry design speed	25–30 km/h	30–40 km/h	40–50 km/h
Number of entering lanes per approach	1	1	2+
External diameter	13–27 m	27–55 m	46–91 m
Central island treatment	Fully traversable	Raised (may have traversable apron)	Raised (may have traversable apron)
Typical daily capacity (veh/day)	≤ 15000	≤ 25000	≤ 45000 (for two lane roundabout)

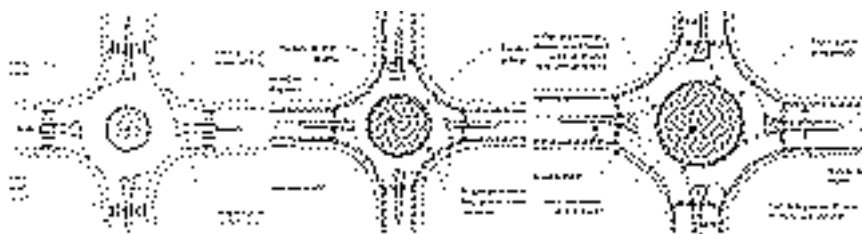

**Figure 4** Types of roundabouts according to the American guides

Mini-roundabouts are most commonly used in urban environment with low speed entries. Splitter islands have to be raised, traversable or only marked. The design according to design vehicle. The width of circulatory lane in single-lane roundabouts varies from 4.8 m to 6 m. Circular shape of a central island is recommended, but oval, irregular or raindrop shapes can also be used. The entry radius is from 15 m to 30 m and the exit radius is from 15 m to 60 m. The traversable portion of a central island is 50–75 mm raised.

Multi-lane roundabouts have at least one entry with two or more lanes which requires a wider roadway in circulating part of the intersection so that at least two vehicles can travel side by side. When driving through multi-lane roundabout lanes do not need to be changed. When entering and exiting a multi-lane roundabout, vehicle must travel by its natural path in order to avoid overlap path. Reaching appropriate deflection along natural vehicle path represents an optimally designed multi-lane roundabout. The width of circulating double lane is from 8.5 m to 9.8 m and of circulating triple lane is from 12.8 m to 14.6 m. Firstly an entry is designed with a smaller radius of 20 m to 35 m, and then with a radius of 45 m and more. The entry lane can be moved to the left in order to obtain increased deflection which reduces it at exit (Figure 5 left). Radius of the fastest path is between 53 m and 84 m which results in design speed of 40–50km/h in the intersection. Determining of the fastest path in a multi-lane roundabout are shown in the Figure 5 right.

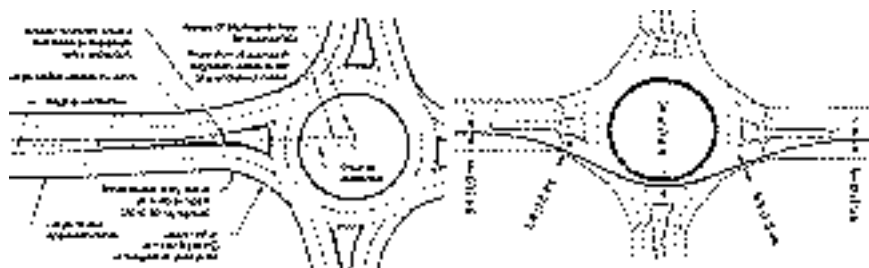

Figure 5 Design of multi-lane entry and determining the fastest path

### 3 Roundabouts in the Varaždin county

The advantages of roundabouts have been recognized by the institutions dealing with management, maintenance and construction of road infrastructure. In the last 10 years City offices, County road offices and the Croatian roads ltd. have been using roundabouts in reconstructing and building intersections.

12 roundabouts are already built and two more are planned. It is important to point out that 79 % of  $\gamma$  and  $\tau$  junctions were covered to roundabouts and the rest 21 % of them are new intersections. According to the types they are small roundabouts with one circulating lane, one entry and one exit lane. In 36% of intersections a bypass lane was designed to increase the road capacity and to take right turning vehicles outside of a circulating lane (Figure 6). The geometric design analysis shows the implementation of modern design elements (Table 5).



Figure 6 Single-lane roundabout with additional lanes for the right turn

Table 5 Design elements of roundabouts in the Varaždin county

	Single-lane roundabouts	
	urban	rural
External diameter	29 m – 33 m	36 m– 48 m
Entry radius	12 –16 m	12 m–20 m
Exit radius	14 m –16 m	14 m –20 m
Circulatory lane width	7 m–8.5 m	6.5 m–7.5 m

Vehicle distance from the central island by the value of two lanes provides low speed in the circulatory lane in all the roundabouts. Although 90% of roundabouts are designed to have traversa-

ble central island only 40% of them are built as paved surfaces (granite blocks) when related to asphalt circulatory lane. It is recommended for the central island to be made of different material and raised up by apron which increases the safety conditions from a number of aspects. The Figure 7 shows the roundabout in Ludbreg with splitting and central island raised by blocks and a mound covering the view of the opposite entry lane. The central ring is made of granite blocks which provide the circulating traffic to stay in the lane and it provides additional width to be used only by larger vehicles.



Figure 7 The roundabout in Ludbreg

## 4 Conclusion

The insight into achievements in roundabouts design is characterized by the basic principle of speed controlling through the geometric design resulting in the improved safety of intersection. Different types and their basic characteristics show uniformity in all the countries that were considered. Single-lane roundabouts represent a standard solution. There are different elements of geometric design defining the basic characteristics of single-lane roundabouts. The Swiss guides define an entry angle and a deflection angle while the American guides test the fastest path speed. In all the countries mini-roundabouts are used with a diameter of 27 m and less and a traversable central island.

There are some differences in the design approach with multi-lane roundabouts. The German guides allowing only one exit lane at double-lane roundabouts have a restrictive approach. In the American guides the entry and exit radius are increased due to the principle of a natural path in order to avoid path overlap while entering and exiting.

Disadvantages of multi-lane roundabouts can be eliminated by using turbo roundabouts.

The design of roundabouts in the Varaždin county follows the modern guides. The solution of the traffic safety also has to be found in the use of other types of roundabouts. Creating the national guides based on positive experiences from all around the world could significantly contribute to the safe and unified use of roundabouts.

## References

- [1] Merkblatt für die Anlage von Kreisverkehren, Ausgabe 2006, Forschungsgesellschaft für Straßen- und Verkehrswesen, Köln
- [2] Schweizer Norm 640 263, (1999.g.) - Knoten mit Kreisverkehr, Vereinigung Schweizerischer Strassenfachleute (vss), Zürich
- [3] RVS 03.05.14 Straßenplanung, Plangleiche Knoten - Kreisverkehr, 2010.g. Österreichische Forschungsgemeinschaft Straße und Verkehr, Wien
- [4] NCHRP: REPORT 672, Roundabouts: An Informational Guide, Second Edition, 2011.
- [5] Fortuijn L.G.H.: Turbo Roundabouts: Design Principles and Safety Performance, Transportation Research Record: Journal of the Transportation Research Board, ISSN0361-1981, Volume 2096/2009.
- [6] Fortuijn L.G.H., Carton P.J.: Turbo Circuits: A well-tried concept in a new guise, Board of Economy and Transport, Province of South Holland, objavljeno na [http:// www.pzh.nl/](http://www.pzh.nl/) 2001.



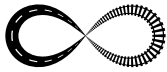

## RENAISSANCE OF THE RAILWAY CONNECTION TRSTENA–NOWY TARG

Juraj Muzik, Zuzana Gocálová, Andrej Villim, Janka Šestáková, Ľubomír Pepucha  
*Faculty of Civil Engineering, University of Žilina, Slovakia*

### Abstract

Common projects of the crossborder cooperation – Žilina and Silesia counties – exceed the borders of our states. Map as a scaled and generalized image of earth's surface, created on the basis of specific mathematical rules, provides tools for the description of economical and social aspects as well as cultural, natural and social heritage of the regions using map language. As the map shows georeferenced spatial data and their relations, the map becomes the platform for creation of the information systems for regions. On the Polish and Slovak sides the map is created using different cartographic view.

*Keywords: track, crossborder cooperation, railways*

### 1 Introduction

In the context of the projects 'Transportowe studium przedolimpijskie – Zakopane 2008' and 'Tatzański system komunikacyjny a ochrona przyrody', a study for renovation of the railroad track Trsten–Suchá Hora, which belongs to the obsolete railroad connection with Poland, Trstená–Nowy Targ, was born.

The objective of the study is to connect the Orava region with the Cracow region and to widen economical relations between regions and states. This objective requires a modernization of the existing traffic structures. The study assumes the load movement from truck traffic to the railroad, which is more economical, energetically safe and is with less influence on the living environment.

Other advantages are the thinning of traffic on the road communications in favour of personal transport, which is more effective in the context of traffic safety and road maintenance. Reactivation of the historical railroad, which integrates from the beginning of the 20th century the regions on both sides of the High Tatras, will create the connection between regions with rich cultural and historical values. A development of conditions, that will intensify tourist traffic and the economical and social development of the regions, will occur.

### 2 Nature of the railroad space Trstená–Suchá Hora

Cross station railroad space Trstená – Suchá Hora was, as a part of Oravian local railroad 3rd section, opened on 21.12.1899. To Poland the track was extended during the year 1904 (track Nowy Targ – Podczerwone – Suchá Hora).

This rail track was running until 1975, when the traffic deputy cancelled the service on this railroad. The rail track upper structure was destroyed during the eighties, but the earth structure was kept in its original conditions.

The track is connected to the existing rail station Trstená in km 56,930 and it goes to km 70,406 where the track ends on the border with Poland near Suchá Hora village.

The proposal for a new track is using the existing directional conditions of the cancelled track and existing earth structure. Another condition was that the maximal speed is to be 80km/h, and this value was used to derive other base rail structure parameters.

Maximal uphill gradient on the track do not exceed original uphill conditions e.g. 21,803‰. Proposed maximal uphill was determined according to the standard TNŽ 736301 'Design all-state tracks with normal gauge' article 31 'for design speed  $V = 80$  km/h and less, the slope could not be more than 20‰.'

Minimal radius is  $r = 320$  m, maximal uphill in the track arc  $p_{d1} = 150$  mm. Continual transition between the straight track and the arc is designed using a cubic parabola spiral curve.

Objects on the track are fully functional, and during potential renovation they should be cleaned and modified to meet the service conditions. Some bridges were removed and renewal of the service requires creation of new bridges.

The track is designed as a monorack with one level crossing with local communications.

Design of the earth structure is based on the theoretical knowledge and visual findings. After geotechnical survey the structure character might change which may lead to lowering costs. Subsurface layer is designed from gravelous sand with minimal grain diameter of 300mm.

The designed upper part of the railroad embankment is the S49 type using concrete crossties SB8.

The track is designed as a monorack with total length of 13,364 955 km, number of railway bridges – 4, crossings – 15, floodgates with a pipe – 9, slab floodgates – 6, vault floodgates – 2, viaducts – 2 and designed traction – motor.

### 3 The characteristic design of railway stations

Railway station Suchá Hora is positioned on the 69,869 340<sup>th</sup> km, station begins on the km 69,468 854 with the rail switch object no. 7 and ends on the km 70,240 339 with the rail switch object no. 1. The total station length is 771,485 m. In the dispatcher building there is waiting room, entrance hall and a cash-desk. Through the entrance it is possible to exit and enter the platform, for continual access between platforms the slab subway is designed. The station building is under reconstruction.

The railway station Suchá Hora is designed for track speed of 80km/h on the main track and track speed of 50km/h on side tracks. The station has 4 tracks. Axial distance between the track no.4 and no. 2, as well as between track no.1 and no.3 is 5m, axial distance between the track no.1 and the track no.2 is 10 m.

Railway tracks are designed using the following rules. Track no.1 of the new state is identified with the track no.1 of the old state. This track is the main entrance and exit track for all trains and its effective length is  $l_{uz} = 550$  m. Track no.3 is the side entrance and exit track for all trains and its effective length is  $l_{uz} = 518$  m.

The service handling track, track no.4 with the effective length  $l_{uz} = 566$  m and track no.2 with effective length  $l_{uz} = 566$  m, are used mainly for loading and unloading or as store tracks. Designed rail superstructure is type S49 with gravel bed of thickness min.  $hk = 300$  mm on wooden crossties 1A types.

Rail switches no.1, 2, 3, 4, 5, 6, 7 were designed as ratio switches of the S49 type on the wooden crossties. South track head was designed as an arc head with the radius of  $r = 600$  m, to keep effective track length  $l_{uz} = 550$  m. Rail switches no.7, 5 is transformed to the arc with speed of 50 km/h, the switch no.6 is transformed outside of the arc with speed also 50km/h. To level super elevation on track no.3 the arc was designed with  $r = 429,723$  m and a spiral curve, on the track no.4 the arc is designed, with  $r = 645,801$ . On the northern rail head the arcs with radius  $r = 200$  m and  $r = 500$  m are designed.

On the rail station Trstená, with the reason of using modern rules of goods transfer and using higher standards of traffic services, the study was counting on combination traffic. Using com-

combination traffic requires reconstruction of the railway station Trstená along with the creation of the combination traffic terminal.

## 4 Conclusions

Considering the suggested resolution of monorail Trstená–Suchá Hora (state border with Poland) with maximum speed of 80 km/hour and length of 13,365 km the total costs were estimated as 28 672 811 €, which presents 2 145 366 € per 1 km.

The suggested railway connection creates good conditions for economical-commercial trade and social growth of the regions. It gives the opportunity to make closer connections and attract people to the regions as Orava, Spiš, Liptov and Pieniny. These are the areas with huge potential for tourism with architectural, cultural and natural national heritage. Construction of mentioned monorail requires coordinated management of this project. Possible solution is an extensive cooperation with the Polish side where both parties will participate on the management. This management would consist of full project management, plus financial studies impact, commercial and financial affectivity, full preparation stage including the application for sponsorship from the European funds and all planning and executive steps. Project realization could play the key role in strategic forming of the regions as well as subject related to these and their successful presentation within international competitors.

## Acknowledgements

This contribution is the result of the project implementation: 'Support of Research and Development for Centre of Excellence in Transport Engineering' (ITMS: 26220120031) supported by the Research & Development Operational Programme funded by the ERDF.



'We support the research activities in Slovakia'.



## References

- [1] MALÍČEK, I., a kol. : Projektovanie, stavba a rekonštrukcia tratí, vŠBs Žilina,1993
- [2] KOŤKA, V.,: Digitálne mapy s AutoCADom - 1. diel AutoCAD, cd verzia, 2006, strán 340, ISBN 80-8070-482-1
- [3] IŽVOLTOVÁ, J., KOŤKA, V.,: Kartografická interpretácia niektorých atribútov databázových štruktúr, 17. kartografická konferencia, Bratislava 6. 7.9.2007, ISBN 987-80-89060-11-5
- [4] MASAROVÍČOVÁ, S. - SITÁNYIOVÁ, D.: GIS application for solution of the problems of public transportation system in Žilina, Communications - scientific letters of the University of Žilina. ISSN 1335-4205. - Vol. 6, Nr. 3 (2004), pp. 47-50.
- [5] HODAS, S. - ŠESTAKOVÁ, J.: Railway track modeling in 3D system. In.: xx Polish - Russian - Slovak Seminar Theoretical Foundation of Civil Engineering Warszawa and Wrocław, Poland, 5.-9.9.2011, p. 355-360. - ISBN 978-80-970248-6-4
- [6] KICOVÁ, E.- PALIDEROVÁ, M.: The importance of comparative analysis at appraisal of company's financial health In: Obchod, jakost a finance v podnicích - determinanty konkurencieschopnosti vi : sborník příspěvků z mezinárodní vědecké konference konané ve dnech 16.-17. dubna 2008 na České zemědělské univerzitě v Praze pod garancí katedry obchodu a financí, provozně ekonomické fakulty. - Praha: Česká zemědělská univerzita, 2008. - ISBN 978-80-213-1774-1. - S. 78-81.
- [7] MUŽÍK, J.: Použitie GIS pre určovanie stability svahov. In: Sborník studentské konference GISáček 2005: Ostrava, 2.5.-3.5. 2005. - Ostrava: VŠB - TU, 2005.
- [8] MUŽÍK, J. - SITÁNYIOVÁ, D.: Aplikácie GIS v geotechnickom prieskume zosuvných území. In: Geotechnika v urbanizovanom prostredí = Geotechnics in urban areas : zborník 7. Medzinárodnej geotechnickej konferencie, Bratislava 27. a 28. júna 2005. - v Bratislave: Slovenská technická univerzita, 2005. - ISBN 80-227-2225-1. - S. 117-122.

**17 VEHICLES**



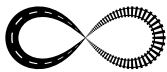

## BOARDING ACCESSIBILITY TO TRAIN VEHICLES FOR EVERYONE

Bernhard Rürger<sup>1</sup>, Goran Simic<sup>2</sup>

<sup>1</sup> Vienna University of Technology, Austria

<sup>2</sup> University of Belgrade, Serbia

### Abstract

EU regulations require that public transportation systems be accessible for everyone without any restrictions. This includes not only disabled people, but also elderly, passengers with baby carriages, big sized luggage etc., i.e. all people with some kind of reduced mobility. Assuring accessibility for all is an inevitable future obligation for railway operators. The interface between the platform and the rail vehicle is one of the largest railway accessibility problems particularly for wheelchair users. To advance the current situation a project consortium (PubTrans4All) funded by the EU in FP7 will develop a new boarding assistance system that can be used not only by wheelchair users, but by other people with reduced mobility.

*Keywords: accessibility, vehicle entrance, boarding assistance device, PRM*

### 1 Introduction

The process of boarding rail vehicles consists of several connected steps: passengers must get to the rail station; they must get to the platform; finally, they must get from the platform to the rail vehicle. Once on the rail vehicle they must have an appropriate space in the vehicle and access to various services. The process of alighting follows the same steps in reverse. The PubTrans4all project - funded by the EU within the 7th framework programme - focuses on the problems of people with reduced mobility when getting from the station platform into the rail vehicle. The project's main goal is the development of a better boarding assistance system (BAS).

#### 1.1 Main problem—existing high floor vehicles

The main accessibility problem for rail transport operators is that many old trains, suburban or tramway lines have significant vertical differences (e.g. steps) and horizontal gaps between the vehicle and the platform. This problem is accentuated by the fact that rail rolling stock and infrastructure has a very long service life. Railway operators will use their current rolling stock for many more years and therefore, temporary solutions must be found until the fleet can be replaced with modern fully accessible rolling stock.

#### 1.2 Difficulties – huge variety of platforms and vehicles

It is difficult to develop a standard accessibility solution because of the huge variety in rolling stock and platform heights. Even on a single railway line several different types of rolling stock are often used and platforms may have different heights and profiles. Moreover, the exact physical dimensions of rolling stock (e.g. height) can also vary depending on its occupancy

and wear. Designers must also consider a safety margin between the train and platform to account for train rocking etc. Finally, accessibility devices must work under all types of environmental conditions (e.g. rain, snow, etc.).

## 2 Evaluation Criteria for boarding assistance systems

The PubTrans4All-Consortium developed an evaluation criteria catalogue of all relevant parameters that need consideration when designing a new boarding assistance system. The following tables give a summarised overview of the evaluation criteria. Features rated as not important, are not shown herein.

### 2.1 User related criteria

For wheelchair users and some groups of people with walking disabilities like people being depended on walking-aids, technical boarding assistance systems are a must in order to be able to board a high-floor vehicle.

For most other passengers the use of a Boarding Assistance System would be a 'nice to have' feature. These passengers are the ones with luggage or baby prams, persons with walking disabilities, which are the absolute majority of passengers. On one hand this leads to the fact that these groups also need be content when using a train, and especially while boarding, on the other hand it is not possible to offer technical devices which require a longer operational time, and do block the entrance for other passengers like lifting devices, normally being used for wheelchair users only.

For big group of travellers it is ideal that personnel assistance is asked for before boarding, because in this way, only passengers needing help will call on it, and staff can also act flexibly and quickly. The ultimate solution, ideal for all passenger-groups, is a level boarding situation. Technical devices like automatic gap bridging systems, or occasionally short ramps can also be used for all passengers without causing any train delay.

Another user-related criterion is automatism. The possibility of operating boarding assistance systems automatically scores as 'impotent'. Automatisation means that the system either works automatically in each and every station (e.g. folding steps or gap bridging systems), or can be operated by the users themselves. The difficulties of offering systems operated by the users are not technical reasons, but safety and legal issues.

**Table 1** Boarding assistance – necessity for different user groups

Score	Users
Very important ("must have")	wheelchair walking frame
Important high benefit for users & operators ("nice to have")	baby prams walking disabled with a crutch or sticks elderly diminutive people passengers with luggage
Less important ('nice to have' - but not absolutely necessary)	children pregnant visual and hearing impaired

## 2.2 Operator and manufacturer related criteria

**Table 2** operator and manufacturer – evaluation criteria

Framework Requirements	limit
Very important ('must have')	Reliability of boarding assistance system: Prevention of malfunction Operational quality: Short dwell time Operational effort: Number of required staff Failure management: Problems easy to solve Costs: Costs as low as possible Safety risks: No safety risks to be tolerated Safety/Alert features: Visual , e.g- flash-light, contrast etc, and audio signals Maintenance effort: Number of personnel required? Special tool required?
Important high benefit for operators ('nice to have')	Operational quality: malfunctions must not influence train operations Universalism: The system needs to be universal and allow retro-fitting Manufacturing effort: The manufacturing/installation effort needs to be low – especially when retro-fitted on vehicles
All regulations according to TSI-PRM must be fulfilled as a minimum standard. Some specifications in project PT4All have been set higher and in more detail than the minimum requirements as specified in the current version of the TSI PRM.	

Table 2 shows an overview of the importance of different criteria that a boarding assistance device must fulfil, e.g. technical features, from the operators' point of view. Most criteria are evaluated as 'very important' by the operators, especially a high level of reliability, operational quality, easy maintenance, low cost, and no safety risks are scoring high as very important.

## 3 Improving the vehicle accessibility situation on the rolling stock

Improving accessibility means either creating level-boarding situations by adjusting the platform height according to the vehicle floor height, or providing boarding assistance systems that enable mobility impaired passengers to reach rolling stock floor levels from the platforms at different levels. There are two main types of boarding assistance systems: platform-based and vehicle-based versions.

Platform-based systems are usually manually operated devices simple to apply. At least one device is needed at each station that is usually only suitable and designed according to wheelchair user's specifications and needs. One person per station should be available as boarding assistance system operator. Before the train arrives at the station, the boarding assistance system must be moved to the exact position on the platform where the adapted vehicle for wheelchair users is expected to stop.

The advantage of all vehicle-based devices is that they are always available, i.e. at the right time and place and in all stations) as they are stored on the train-vehicle. This enables people with reduced mobility to travel even without making travel-arrangements in advance. This is very important for both the users and the accessibility policy of the railway operators.

The on-board conductors are trained to operate this kind of boarding equipment, which is more convenient for operators than the use of platform-based boarding assistance systems. For each boarding assistance system there are two main technologies: ramps or lifts; and, two sources of powering them, manual or electro-mechanical.

A short overview of existing systems that are typically used for high floor vehicles is given in the following chapters. Existing systems for low floor vehicles, i.e. gap bridging systems, are not part of this project.

### 3.1 Ramps as a Boarding Assistance System

Ramps are generally the simplest and least expensive boarding assistance devices. However, they can only be used if the vertical difference between the vehicle floor-platform is not significant, typically not more than one step, since otherwise the ramp gradient would be too steep in order to use the device safely, otherwise the ramp-platform would be too long to be used on narrow platforms. Most ramps cannot be operated without the assistance of the rail operating staff.

There are five different types of ramps based on boarding assistance systems solutions: platform-based manual ramps, vehicle-based manual ramps, vehicle-based electro-mechanical ramps, vehicle-based and platform-based gap-bridging devices to close horizontal gaps only.

#### 3.1.1 Manual Ramps – platform-based applications

A movable ramp is usually located on the station platform and requires staff assistance to be operated.

Manual ramps must have an ergonomic design, both for the wheelchair users' comfort and also to ensure good operating conditions for the train-staff such as weight, manoeuvrability, etc. If a boarding assistance system is easy to handle, staff will be more willing to use it. Fig.1 shows an example of platform based ramps used in Norway.



Figure 1 Platform based Ramp NSB, Norway

Several railway transportation operators are using manually deployed ramps for high floor vehicles also, although ramps do have their technical limits.

#### 3.1.2 Manual Ramps – vehicle-based applications

Vehicle-based manual ramps are ramps located on the train vehicle. They also require the assistance of the rail operating company staff to be deployed and used. The advantage of vehicle-based ramps is that they provide accessibility to all stations from the train since they are stored on board. The ramps may be permanently attached to the vehicle or simply stored on the vehicle.

Fig.2 shows the example of a vehicle based ramp used for bridging vertical gaps, and height differences where needed. Such short ramps can theoretically be used by all passengers. Some operators provide such easy to handle ramps in each station. The main advantage of manual, vehicle- or platform-based ramps is that many passengers, other than PRMs, are using that particular entrance for their convenience, as the provided ramp is more comfortable than taking an entrance with a step, or more than one. The ramp as shown in Fig.8 can be stored on board but also on platforms.



**Figure 2** Manual mobile Ramp (Port-a-Ramp, UK), bridging the gap between the train and the platform (South Eastern Trains, England)

### 3.2 Lifts as Boarding Assistance System

Lifts are mechanical lifting devices either installed on the vehicle, or mobile lifts placed on the platform. Lifts are the preferred solution over ramps in situations of great height differences, usually more than one step, where slopes are too steep for the application of ramps but also on very narrow platforms on low floor vehicles if ramps are too long.

A key advantage of lifts is their vast flexibility. Platform-based lifts can be adapted to almost all types of rolling stock and stations since they can be moved around on the platform and can bridge variable horizontal gaps and vertical changes. Similarly, vehicle-based lifts can be adapted to many different platform heights accordingly.

#### 3.2.1 Lifts – platform–based applications

These lifts are operated by train-operating staff and are usually pushed on the platform to the train door and then manually operated. Similar to manually deployed ramps, these lifts require ergonomic design, not only to be used for the wheelchair users, but also for the staff who moves and operates the lift. Fig. 3 shows an example of platform-based lifts.



**Figure 3** Platform based lift used in Switzerland (and many more countries)

#### 3.2.2 Mechanical Lifts – vehicle–based applications

They consist of elevator platforms that deploy and unfold from the train, and are operated by the railway operating staff only, due to a complex lift operation, and the operator's legal responsibility, in order to avoid potential injuries.

These boarding assistance systems can be used to provide access for differences in platform to vehicle floor heights of 1100mm, which is more than a platform-based lift can manage.



Usually this type of boarding assistance systems requires a sufficient width of the platform in order to provide enough space for entering the lift platform safely with the wheelchair, but less than platform based lifts. Existing vehicle-based lifts designed for a boarding and alighting process parallel to train are suitable for narrow platforms, which ultimately enhances passenger flow.

An additional advantage of most vehicle based mechanical lifts is the possibility to evacuate wheelchair users under extraordinary conditions in case of an emergency, even without platforms in-between stations, as lifts can usually manage greater floor-to-ground distances than ramps.

Vehicle-based mechanical lifts require an energy source. Two devices must be provided, one on each side of the vehicle. The measurements of the lift platform in a folded stowing position need to be narrower than the door width. Lifts occupy space at the entrance doors and behind it, inside the wagon, which is a difficult situation in classic UIC wagons since space is at a premium. Fig.4 shows examples of vehicle based lifts.



Figure 4 Examples for vehicle based lifts in Norway, Switzerland, Sweden and Germany

## 4 Conclusion and Outlook

Today accessibility is a must for each railway operator – not only because of regulations. One special barrier is the link between the platform and the wagon. Two possibilities are state of the art – either level boarding which means accessibility and advantages for all passengers and the operator, i.e. shorter boarding time, or classical high-floor railway coaches fitted with steps, which represent boarding and alighting problems for mobility impaired people. The second case will be an ongoing situation within the next decades in the field of long-distance travelling, especially in high speed traffic. Here we need some kind of boarding assistance devices to make vehicles accessible, especially for wheelchair users. A variety of types of railway vehicles and the variety of platform heights lead to the today's situation of having various different solutions for making boarding accessible. The PubTrans4All project tries to find a standardized boarding assistance device that can be implemented in as many coaches in Europe as possible and can be used at a variety of different platform heights. Additionally the project tries to find a technical solution for as many of the users as possible.

The goal of the PubTrans4All project is to develop an improved boarding assistance system, in order to facilitate the accessibility of railway vehicles. The project is being completed as part of the EU Commission's 7th Framework Programme.

The project's first step completed was the development of evaluation criteria for both existing and new boarding assistance system to be designed. The second step was the completion of a comprehensive research study about existing boarding assistance systems across Europe and the world, and finally to evaluate these boarding assistance systems and apply those criteria accordingly.

The results of these activities illustrate the complexity of developing a universal and standardised boarding assistance system solution which shall work for as many types of vehicles and platform conditions as possible.

The project focuses on the most difficult scenarios of accessibility situations for classic UIC wagons, expecting an effective solution for these vehicles, being universal and covering most other types of rail vehicles as well.

By creating an 'Existing Boarding Assistance System Evaluation Matrix Report', the evaluation and assessment of existing solutions has been performed. Further steps included the definition of recommendations and requirements for new boarding assistance system for existing UIC type vehicles, provided and developed by a task-force, the 'Prototype Development Group of the FP 7 PubTrans4All Project', consisting of the Vienna University of Technology and University of Belgrade, industrial manufacturers such as MBB Palfinger as the developer of the Boarding Assistance System, Bombardier and Siemens for the train-vehicle side, BDŽ, the Bulgarian passenger railway operator, and Rodlauer Consulting, project coordinator. A final Prototype Solution will be presented at the Innotrans 2012.

## References

- [1] [Rüger B, Tauschitz P, Vienna University of Technology; Petutschnig B - BP International Consulting, Boarding Assistance System Evaluation Criteria Report, Deliverable 2.1, June 2010. EU-FP7-Project Public Transportation – Accessibility for all
- [2] Rüger B, Tauschitz P, Vienna University of Technology; Petutschnig B - BP International Consulting, Existing Boarding Assistance System Evaluation Matrix Report, Deliverable 2.2, August 2010. EU-FP7-Project Public Transportation – Accessibility for all
- [3] [www.pubtrans4all.eu](http://www.pubtrans4all.eu)



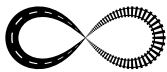

## RAILWAY INTERIORS IN ORDER TO REDUCE DWELL TIME

Bernhard Rüger

*Vienna University of Technology, Austria*

### Abstract

Today, passenger exchange of trains is mostly insufficient. The most important factor determining exchange times is passenger behaviour which is influenced by traveller characteristics, like age and / or mobility constrictions, the amount of luggage and finally the vehicle's design. On days with high passenger-frequencies prolonged passenger exchange time results in extensive stop-over time. This leads to delays, which can also influence other trains and therefore cause further delays. Any delay reduces customer satisfaction, which, on the other hand, shifts modal split to the disadvantage of public transport.

An extensive investigation at the Institute for Railway Engineering at Vienna University of Technology analyses exactly passenger exchange times and intends to demonstrate potential for improvement.

*Keywords: passenger exchange, customer satisfaction, dwell time, railway interiors*

### 1 Introduction

There are two alternatives for designing passenger vehicles. One possibility is to try to obtain the maximum number of seats per wagon in order to increase capacity; the other is to take care of passengers' needs and expectations.

The first case is highly inefficient. Not more than 80% of the seats offered can be taken, the dwell time may triple and safety risks will rise. However more efficient vehicles can be designed by taking actual passenger behavior into account. This is the conclusion reached by Vienna University of Technology (TU Vienna), following 10 years of studies by its Research Centre for Railway Engineering. Passenger vehicles can be divided into three areas with different influences on passenger behavior. Firstly immediate access, secondly the entry area and thirdly the passenger saloon. The general design of all three decides whether the wagon or the whole train can be operated efficiently or not.

### 2 Access

Too narrow doors, too steep and too many steps cause difficulties especially for the elderly, handicapped or simply for passengers with luggage, prams or bicycles. With regards boarding trains in various situations, i.e. different vehicles combined with different platforms, the problems faced by passengers can be categorised as following:

- Cat 1: level boarding, one stair step max.: travellers of all ages, with or without luggage, rarely have difficulties
- Cat 2: access with two stairs, wide doors and stairs with flat angles: travellers with luggage independently from age rarely struggle when accessing the vehicle. Nevertheless more than 10% do have severe and very severe difficulties, of which 7% need assistance
- Cat 3: access with UIC-wagons and related trains (three steps from platform): Between 10–15% of travellers have difficulties or a lot of difficulties when accessing the train without

luggage and 25–30% when carrying luggage. Whereas only between 1 and 2% need assistance for themselves, more than 10% need assistance for their luggage

- Cat 4: old-type vehicles, steep stairs (three to four steps from platform): 20–30% of travellers do have difficulties and severe difficulties without and 50% of travellers with luggage. Approximately 20% of travellers having luggage do need foreign assistance. Approximately 8% amongst the group of 40 to 59 year old, and approximately 20% amongst the group of over 60 year-old, require personal assistance when accessing the vehicle

Figures 1 and 2 illustrate the combinations and connections between parameters such as access type, luggage and passenger age:

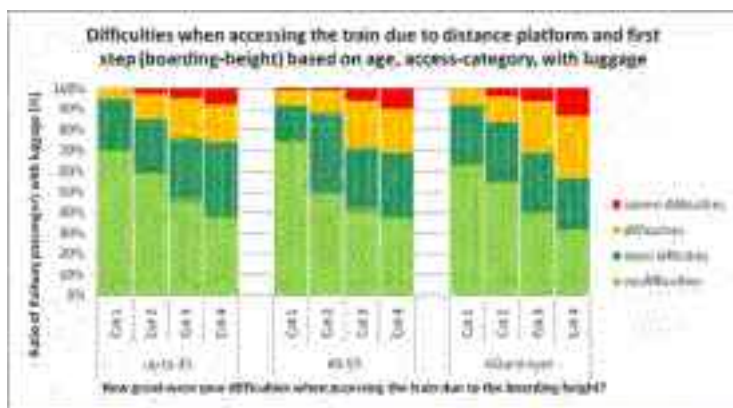

Figure 1 Difficulties encountered by passengers with luggage when accessing trains



Figure 2 Assistance required when boarding with luggage, based on different access categories

Surveys clearly reveal that the majority of travellers have no trouble when using an access without a step or even just one. However negotiating two steps with luggage is more problematic. To speed up passenger flow in stations to gain shorter dwell times, the most comfortable access possible must be provided – in the best case level boarding, in the worst, two, non-step steps and wider doors (at least 90cm). In addition to the operating benefits, customer satisfaction will rise too.

### 3 Entry area

The entry area must also function as retention area. Since passengers always walk in a row, a wide space is unnecessary – it is more important that passengers need to go a longer way before they enter the passenger saloon.

For example, in compartment coaches passengers normally need to walk further to reach the first compartment, but also many trains such as the German ICE have a longer route at least at one car end because of the toilets. Even more effective entry areas are those leading to a division of the passenger flow, as occurs in the old Danish IC3 trains or generally in double deck trains.



Figure 3 Entry area as retention room

A missing retention area causes an earlier passenger tailback from the passenger saloon plus dwell times may rise considerably. Vehicles with well-designed entry areas and the possibility of passenger flow division deliver shorter dwell times than conventional wagons. This time difference can be up to 100%.

### 4 Passenger saloon

The passenger saloon is the area in a train where most design mistakes can be found. A too narrow aisle, too little space for luggage and a uniform adjustment of seats lead to trouble with passenger flow, strongly reduce the number of available seats and increase passenger dissatisfaction.

#### 4.1 Passenger behaviour, difficulties, needs & expectations

Passengers behave differently depending on their age, group size, gender and especially luggage. Most travelers on high-speed or long distance trains have luggage. This circumstance is not taken into account in most of the trains in service today. Approximately every passenger has one medium or large bag plus hand luggage. Regarding luggage storage, this raises two points:

- passengers do not want to lift up their bags
- passengers want eye contact with their bags

The fact is that for each passenger approximately the space for one item of luggage must be offered. Otherwise travelers will store their belongings on or in front of seats, in the aisle, etc. This occurs not only when there is no or insufficient space for the luggage but also when storage is badly designed. As mentioned above, passengers must not be coerced into lifting up their bags. Most of them won't do it. Similarly they want to keep an eye on their possessions. And if they can't, they will once again store it close by. Both facts result in the following behavior – if there are no luggage racks nearby, offering comfortable storage, passengers will store all their belongings, including large items, close at hand on the floor.

Interior designs providing unsuitable and insufficient space for luggage will increase dwell times because of a rapidly forming tailback caused by bags in aisles, as well as passengers

trying to store them in the overhead rack and blocking the path of others. So where is the ideal space for storing luggage? Two possibilities are efficient and appreciated by travelers:

- Luggage racks in the saloon
- Space between seat backrests

To meet the need for eye contact, the racks must not be in the entry area. Passengers also hardly ever use them if the wagon is fully occupied and there is no space for bags in the saloon. Additionally, racks in the entry impede passenger flow and so impact dwell times. The same is true for those located just inside the saloon at the entrance. In both cases we have 'lost space' because passengers rarely make use of it.

The best solution is to provide racks fitted around the quarter points of the saloon. This location provides good eye contact and causes minimum disruption to passenger flow.

The space between back-to-back seats is also likely to be used. The big advantage here is that there is no need to raise bags, plus they can be stored close to their owners and within eye range.

Besides the location of storage space, its size is important too. Just a few centimeters determines whether the space is efficient or not. For example, if the backrest distance at the top of the headrest of standard seats is approximately 30cm, 95% of all suitcases can be stored upright. If the distance is 20cm, only 20% of large- and medium-sized suitcases can be stored upright, and all of them in a tilted position. When the gap is only 10cm, no more than 20% of medium-sized suitcases can be stored upright. And if one seat is located direct to the other with no distance between the headrests no medium or large luggage items can be stored at all. And unfortunately this is the situation in most rolling stock today!



Figure 4 Lost space for luggage



Figure 5 Old Greek waggon with much and comfortable space for luggage

The same applies to luggage racks. If they are designed 5 to 10cm too low, 50% of suitcases cannot be stored. Likewise if the racks are narrow. For efficient luggage storage every centimeter counts! To ensure efficiency, it is important to take into account the estimated mix of travel purposes then design the storage space on demand. The vast amount of research findings gathered by TU Vienna is proving extremely helpful for precise and efficient designs, which are demonstrated by several research studies.



**Figure 7** Wrong dimensions of luggage racks lead to inefficient storage

#### 4.2 Seat preferences

Beside behavioral problems with luggage, passengers also have different preferences for seats. TU Vienna analyzed real-life passenger behaviour in trains in Austria, Switzerland and Germany. On the one hand passengers were given questionnaires about their wishes and expectations; on the other their actual behavior was analyzed. Out of more than 2,000 trains (about 50 different vehicle types) all information on the real behavior of about 120,000 passengers, combined with personal data, was collected. This database provides precise details on where passengers stow their bags, which seat types are preferred, which ones remain free the longest and much more besides. Special data interpretations of vehicles with different seat configurations in one vehicle and with low utilization rates (about 20% or lower) where passengers have total free choice of seats allow conclusions about which seats are preferred by the travelers.

#### 4.3 Open saloon coach or compartments?

If passengers are free to choose, one half prefers compartments and the other open saloon coaches. As they get older, travelers prefer sitting in open saloons: only about 40% of teenagers prefer open saloon coaches, compared to 55% of adults and 60% of seniors. There are no gender differences if travelling in groups of at least 2 persons but there is a major difference depending on the sex of people travelling alone. While more than 50% of male single travelers choose compartments, only about 20% of women do – 80% prefer the open saloon. In the latter, vis-à-vis seats are chosen approximately as often as row seats.

#### 4.4 Window, aisle or against the direction of travel?

About two thirds of passengers prefer sitting in the direction of travel; one third chooses seats against. About 75% prefer window seats, although this depends on whether they anticipate many passengers boarding the train at the next stations. Passengers don't want to be confined. That means if they are sitting in a facing seat group with a table or in a row seat and



they expect many other passengers to board in the next stations – meaning there is a risk someone will choose the neighboring seat – they will opt for aisle seats. Because others also dislike the confined seats at the window then there is a strong likelihood that others will pass by. And if someone wants to take a free seat than the seat at the aisle allows more freedom. About 80% of passengers choose a seat where the neighboring one is empty because they don't want to be disturbed by others. While around two thirds say they also want to use the free seat to store their luggage.

But although passengers don't want to be disturbed, only around 20% of them who are putting luggage on this empty set do so to prevent anyone from using it! And 80% want their luggage close by or don't want to lift it up.

## 5 Designing around behaviour

The decade of research at the Research Centre reveals that it is vital to take passengers wishes, needs and expectations, plus all knowledge of their actual behavior into consideration when designing new vehicles or redesigning them.

A maximum seat load in a vehicle does not increase the potential capacity. The break point of the maximum possible capacity is about 15% lower than in vehicles in service today. That means that typical, open saloon coaches with about 84 seats only provide capacity of 65 to 70 seats because the others are blocked – mostly by bags that can't be stored because of the lack of space in general or missing storage space to fulfill the passengers' expectations of not lifting up the luggage and having visual contact. Besides the huge 'luggage issue', paying attention to the general behaviour of passengers and their seat choice is also important. Offering a diversified seat arrangement is vital. A good mix between compartments, facing and row seating in open saloon coaches helps meet both passenger wishes but also matches the needs of different group sizes. Fitting interiors for most of the passengers and different groups not only increases satisfaction but also efficiency, since fewer seats will be blocked compared to today. The greatest wishes of passengers that must be taken into account when designing efficient passenger coaches are:

- luggage storage that offers eye contact at floor level
  - most passengers – single travelers or groups – want to isolate themselves from others
  - comfortable access – 90cm wide doors, level boarding or two, non–steep steps (maximum)
  - good mix of compartments, facing and row seating
  - efficiently–designed luggage storage – between seat backrests and in racks. The space between headrests must be at least 20cm in order to efficiently exploit the space for luggage
- This article sums up the key recommendations, but of course there are plenty of others. Nevertheless by following the main suggestions dwell times can be minimized, actual capacity and passenger satisfaction can be maximized and safety risks reduced.

## References

- [1] Rüger B, Loibl C.; 'Präferenzen bei der Sitzplatzwahl in Fernreisezügen'; ETR - Eisenbahntechnische Rundschau, 59 (2010), 11; S. 774 - 777
- [2] Rüger B, Mirkovic S, Radosavljevic A; passenger behavior in boarding situations and relation between platform height and rolling stock floor height, 14. Scientific conference on railways, Nis, 08.10.2010
- [3] Rüger B, Cis P, 'Auslastung in Eisenbahnwagen - Kapazität abhängig vom Verhalten des Fahrgastes' ETR - Eisenbahntechnische Rundschau, 3 (2010)
- [4] Rüger B, Plank, V, Tuna D: 'Des voitures plus confortables et fonctionnelles'; Le Rail 160 (2009), S. 16 - 20

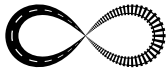

## VIRTUAL ROAD MODELS FROM DYNAMIC MEASUREMENTS

Kai Tejkl, Wolfram Ressel

*University of Stuttgart, Institute for Road and Transport Science,  
Chair for Road Design and Construction, Germany*

### Abstract

For modelling real road characteristics in a driving simulator, a measuring vehicle and an algorithm to generate virtual road models from recorded data were developed. Especially properties which affect driving dynamics and comfort are of great interest. Therefore a standard passenger car was equipped with several instruments to detect the road geometry and the longitudinal profile for describing surface characteristics. After a measurement run, the processing of measurement data is performed offline with a purpose-made software that semi-automatically creates road models in the formats OpenDRIVE® and OpenCRG®, which are widely-used in driving simulators. Therefore several independent steps are necessary. Preliminarily a node-edge model of the investigated road network is established. An algorithm which allows an automated parameter calculation for the standard road alignment elements straight, arc and cubic polynomials, based on the measured, discrete GPS-waypoints was developed with regard to a realistic modelling. This reference line can be amended afterwards by further cross-sectional properties. For this purpose the software visualizes data from a laser scanner. Finally all roads are merged to a network by adding a logical linkage. In the next step, a three-dimensional surface model for each road section is created from longitudinal profiles. The result is stored as an OpenCRG®-model, a 'Curved Regular Grid' where each cell contains discrete height information. In combination with the OpenDRIVE® roads this yields to a visual and haptic road description for the driving simulator. This work was carried out as part of the research project VALIDATE (Virtual Automotive Lab for Integrated Digital Automation Technologies) at the University of Stuttgart leading by the Institute for Internal Combustion Engines and Automotive Engineering with the partners High Performance Computing Centre Stuttgart and the Institute for Road and Transport Science, funded by the German Federal Ministry of Education and Research (BMBF).

*Keywords: alignment, surface, road survey, driving simulator*

### 1 Introduction

The development of new systems in automotive engineering requires always risky and costly tests under real conditions. To reduce these disadvantages the project VALIDATE [1] had the aim to create a research platform to investigate future control and assistance systems in a virtual environment. Therefore one of the biggest driving simulators in Europe was constructed. Within this framework the creation of virtual road models was object of investigation at the Institute for Road and Transport Science. In contrast to the fictitious roads, which are commonly used in driving simulators, this research had the aim to model a real road network including the characteristics of roads, which influence driving dynamics, driving resistance and driving comfort in order to provide a realistic driving experience.

The research consisted of two parts, the design and construction of a measuring vehicle to record the relevant road characteristics and the development of algorithms to process these

data into an appropriate road description. This article gives an overview about the main steps as shown in Figure 1.

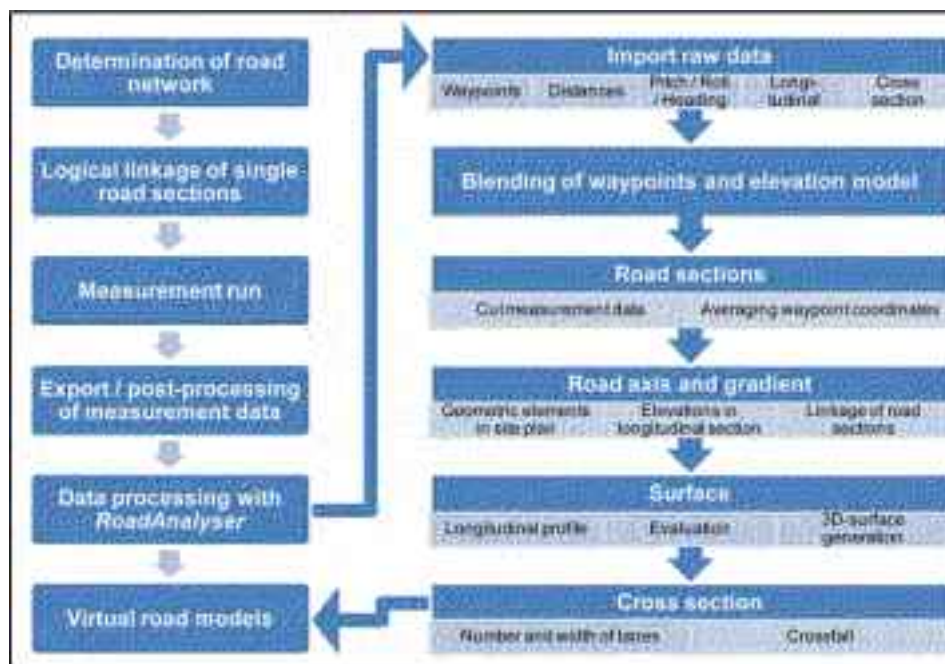

Figure 1 Workflow for creating virtual road models

## 2 Road measurements

Basis of the virtual road models are measurements of the investigated road network carried out dynamically. Therefore a standard passenger car was equipped with different measuring instruments, which amongst others record GPS-waypoints, heading-, pitch- and roll-angle, longitudinal and cross-sectional profile. A data acquisition unit [2] synchronously stores all signals with a time stamp in a single data file and guarantees a consistent data set of all properties. The different measurement instruments mounted at the vehicle are shown in Figure 2. A combined inertial measurement unit (IMU) and GPS-receiver [3] records GPS-waypoints as well as all vehicle motions in three spatial directions in real-time. An additional optical sensor [4] allows a more precise navigation by slip-free measurement of velocity. For the measurement of the longitudinal profile a profilometer as described in [5] consisting of four triangulation laser sensors [6] is used. As the profilometer is mounted flexible, the longitudinal profile can be recorded either in the left or right wheel track. So the resulting road surface can be described by two independent tracks. Crossfall and lane width are determined using a laser scanner [7] at the rear of the vehicle in combination with data from IMU. The scanner measures the distance to the road surface crossways in driving direction over 180 degrees. Two video cameras on the roof additionally record every measurement run.



Figure 2 Measurement vehicle at Institute for Road and Transport Science

### 3 Target data formats

For later visualisation and driving dynamics simulation a common data format for the description of the investigated road network and the road characteristics is necessary. As they are already widely-used the open formats OpenDRIVE® [8] and OpenCRG® [9] were chosen. The open XML-format OpenDRIVE® allows a hierarchical description of all road characteristics. Within a road network single road sections corresponding to the node-edge model in section 4 are determined. These are linked by their unique ID. A particular role is given to junction areas as the roads inside this area allow a lane-specific connection of each incoming and outgoing road. The geometry of each road section is initially described by a reference line (the road axis) in the site plan, consisting of the geometric elements straight, arc, spirals or polynomials with reference to an absolute x/y-coordinate system. Along the reference line a relative s/t-track-coordinate system is introduced as basis for all further descriptions like the elevation profile, lane width or positions of signs and signals. Additionally to the OpenDRIVE®-format the OpenCRG®-format describes the three-dimensional surface characteristics. Basic principle of OpenCRG® is a two-dimensional regular grid along the predefined reference line in longitudinal and cross direction. A discrete height-value in z-direction is defined for each cell thus results in a three-dimensional surface. The resolution of the grid can be chosen arbitrarily. However, small excitations won't influence the driving comfort.

### 4 Preparation of road network

The investigated road network has firstly to be determined and transferred into a node-edge model with unique ID's where all junctions are divided into several sub-nodes and the edges represent single road sections between them. An example of the dissolved junction ID = 1 is shown in Figure 3: The sub-nodes 1E, 1W and 1N are defined on the road axis of each access to the junction. Incoming and outgoing roads ID = 1, 2 and 3 to the adjacent junctions are then treated as free road sections. Every possible connection between the sub-nodes is finally described by six separate connecting roads ID = 11 to 16.

As almost every junction has own characteristics – especially complex junction areas like interchanges with a lot of sub-nodes – this preparatory step can only be carried out manually with the help of aerial photographs. This concerns also the second preparation step: the logical linkage of all roads and junctions by their ID according to the OpenDrive® specifications. However it's possible to define standard junction types as the linkage e.g. inside a T-junction is always the same.

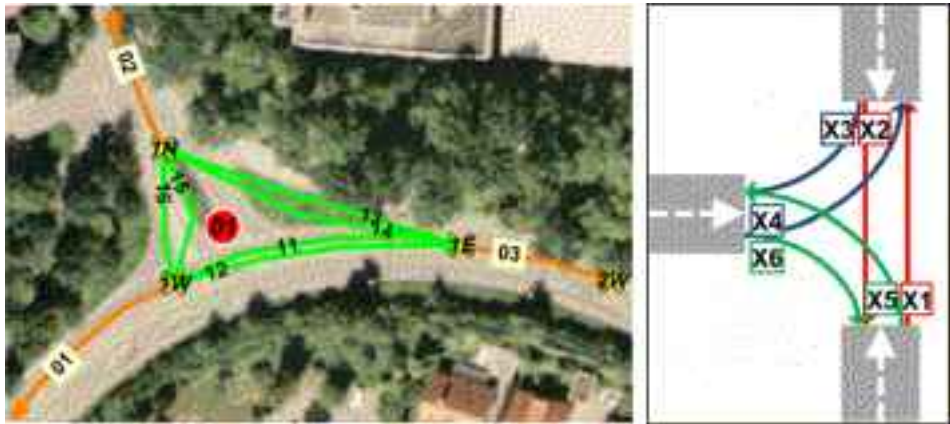

**Figure 3** Example of node–edge model in junction area and standard linkage of a T-junction (Source aerial photograph: LGL Baden Wuerttemberg)

## 5 Road geometry

Main target of the research was the development of an algorithm which generates the virtual road models according to the formats described in section 3 based on the raw data of a measurement run. It was implemented as a MATLAB–Toolbox with the main steps shown in Figure 1.

As described in section 3 the road axis represented by the reference line is essential for all further characteristics like number of lanes, lane width, crossfall and surface. However, the measurement data contain only discrete waypoints. So the continuous reference line described by mathematical functions has to be approximated. On the contrary to other methods which use cubic spline–curves the developed algorithm calculates the geometric standard elements straight, arc and transition curves.

The data preparation initially contains a coordinate transformation into a local metric system. All measurement data of the whole road network are then cut into single sections according to the predefined node–edge model. If a road section was recorded more than one time (along both driving directions), the waypoints of each lane can be averaged to identify the central road axis. Basis for the determination of straights and arcs is the road heading along the track coordinate  $s$  (Figure 4). The heading gradient allows their identification as it can be interpreted as the antiderivative of the curvature. Therefore statistical values of the heading gradient are stepwise calculated. While these values are within a predefined tolerance, constant or linear segments are recognized. Between the known start and end point of each element further parameters (radius, length etc.) can then be calculated.

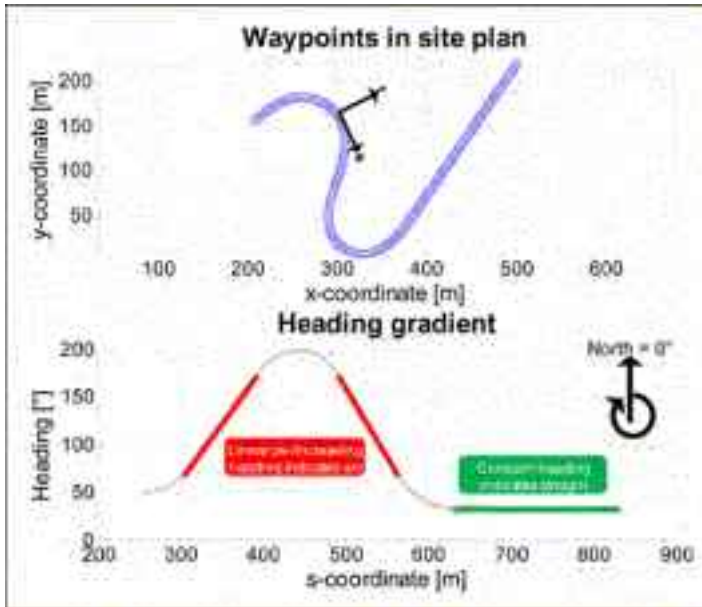

Figure 4 Determination of arcs and straights in heading gradient calculated from waypoints in site plan.

Finally transition curves are fitted between the straight and circular elements (Figure 5). For this purpose 3<sup>rd</sup> grade polynomials described by Eq. 1 are used. The coefficients  $a$ ,  $b$ ,  $c$  and  $d$  of a polynomial element  $i$  are calculated from the boundary conditions derived from the end point of the preceding ( $i-1$ ) and the start point of the following ( $i+1$ ) element (Eq. 2 and 3).

$$y = a + bx + cx^2 + dx^3 \quad (1)$$

$$f(x_{i-1,end}) = f(x_{i,start}) \text{ and } f'(x_{i-1,end}) = f'(x_{i,start}) \quad (2)$$

$$f(x_{i+1,start}) = f(x_{i,end}) \text{ and } f'(x_{i+1,start}) = f'(x_{i,end}) \quad (3)$$

All calculated parameters of straights, arcs and transition curves describing the continuous road axis are then stored in the OpenDRIVE<sup>®</sup>-format and further road characteristics can be attached to this reference line.

The gradient in the longitudinal section is calculated in the same way as described above. However, the elevation profile is used instead of the heading gradient and only continuous defined 3<sup>rd</sup> grade polynomials are assumed.

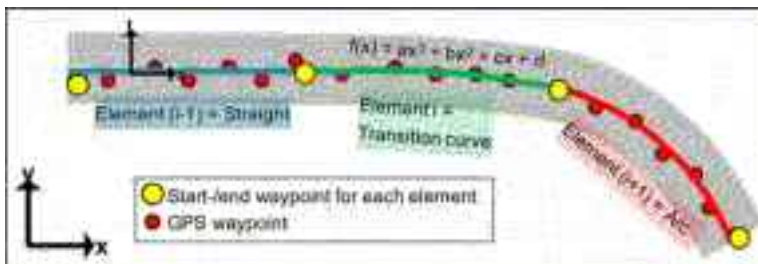

Figure 5 Calculation of transition curve between straight and arc.

## 6 Road surface

The road surface consists firstly of the 'flat' lanes along the previously defined reference line. It is then superimposed by the regular elevation grid.

### 6.1 Lanes

The width of each manually predefined lane can be calculated from the measurement data of the laser scanner. These contain also information about the reflectivity of a laser beam, so light/dark boundaries as they result from the marking along a road can be identified (Figure 6). The abscissa in the diagram of reflectivity specifies the positive  $s$ -coordinate along the road axis and the algorithm searches for the first light/dark boundary in positive and negative  $t$ -direction which represents the road marking left and right of the vehicle in driving direction. The lane width at each  $s$ -coordinate can then be calculated as the absolute difference of the filtered and interpolated  $t$ -coordinates and will be described by an approximated 3<sup>rd</sup> grade polynomial as a function of  $s$ .

Furthermore the crossfall and superelevation of each lane can also be defined. For this purpose, the data from the laser scanner in combination with the synchronous measured roll angle of the vehicle is used.

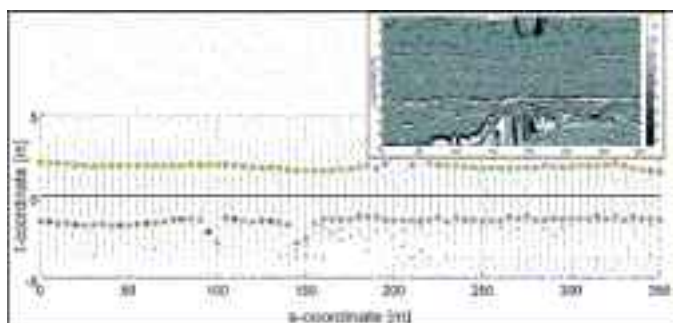
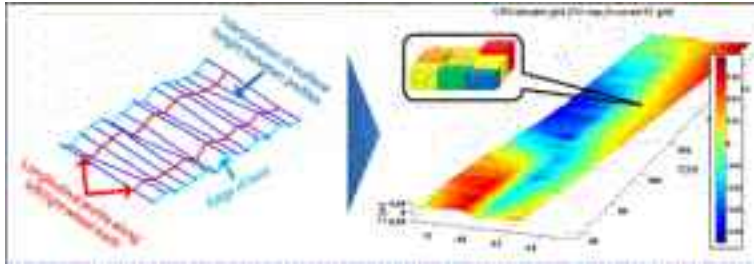

Figure 6 Diagram of reflectivity along the road axis and approximated interpolation points along the lane edge.

### 6.2 Longitudinal unevenness

With regard to a realistic driving experience in the simulator the road models contain also longitudinal unevenness as wave lengths between 50 cm and 50 m, which are mainly responsible for driving comfort [10]. As described in section 2 the longitudinal profiles are measured in both wheel tracks. This especially respects different vehicle excitations [11]. The profile contains all relevant wave lengths and describes the height of the road surface with 10 cm resolution relative to a fictitious base line. Additionally the longitudinal unevenness is evaluated based on the power spectral density at a frequency of  $\Omega_0 = 1/m$  according to German rules for road surveys [12].

The process of generating a three-dimensional surface is shown in Figure 7. The corresponding profile heights between the two longitudinal profiles are interpolated over the wheel gauge respectively extruded to the edge of the lane. According to the arbitrarily chosen resolution of the elevation grid the heights are then discretised and stored for each cell in the OpenCRG<sup>®</sup>-format.



**Figure 7** Interpolated profiles along left and right wheel track and resulting three-dimensional surface model with discrete heights of each cell.

## 7 Conclusions

This article gives an overview about the process to convert data from real road measurements into a virtual road model. Based on this a complete road network can be described including road geometry, cross-sectional properties and surface properties. The road models can be used for visualisation as well as driving dynamics simulation and were already successfully tested in a driving simulator. Furthermore the principle of the developed virtual road models also allows implementation of more detailed properties like short-wave texture.

## References

- [1] VALIDATE - Virtual Automotive Lab for Integrated Digital Automation Technologies, [www.validate-stuttgart.de](http://www.validate-stuttgart.de), 08.02.2012.
- [2] DEWESoft: DEWESoft v6.6 User manual v1.3.0, 2008.
- [3] Oxford Technical Solutions Ltd.: User Manual RT2000, RT3000, RT4000 products, Upper Heyford, 2010.
- [4] Corrsys-Datron Sensorsysteme GmbH: Correvit L-350 Aqua, Bedienungsanleitung, Wetzlar, 2008.
- [5] Still, P.B. & Jordan, P.G.: Evaluation of the TRRL high-speed profilometer, TRRL Laboratory Report 922, Transport and Road Research Laboratory, Crowthorne, 1980.
- [6] Allsens Messtechnik: AR700 Laser-Wegsensor Bedienungsanleitung, Version 2.0, Dreieich, 2008.
- [7] Sick AG: Technische Beschreibung Lasermesssysteme LMS200/211/221/291, Waldkirch, 2006.
- [8] Dupuis, M.: OpenDRIVE® Format Specification Rev. 1.3, VIRE Simulationstechnologie GmbH, Bad Aibling, 2010.
- [9] VIRE Simulationstechnologie GmbH (ed.): OpenCRG® User Manual, 30.03.2010.
- [10] Sandberg, U. & Ejsmont, J.A.: Tyre/road noise reference book, Informex, Kisa, pp. 7-9, 2002.
- [11] Ammon, D.: Modellbildung und Systementwicklung in der Fahrzeugdynamik, B.G. Teubner, Stuttgart, 1997.
- [12] Forschungsgesellschaft für Straßen- und Verkehrswesen e.V. (ed.): Zusätzliche Technische Vertragsbedingungen und Richtlinien zur Zustandserfassung und -bewertung von Straßen, ZTV ZEB-StB, FGSV-Verlag, Cologne, 2007.





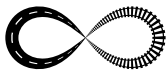

## IDEA AND TESTS OF THE RAILWAY WAGON WITH A ROTATABLE PLATFORM FOR INTERMODAL TRANSPORT

Tadeusz Niezgodą, Wiesław Krason, Wiesław Barnat

*Department of Mechanics and Applied Computer Science, Faculty of Mechanical Engineering, Military University of Technology, Poland*

### Abstract

In recent years, combined systems based on vertical or horizontal handling have been implemented into European railway transport. In vertical and horizontal systems, loading and unloading require special terminals. Vehicles, using their own engines, are driven on and off platforms through a ramp at the last carriage (horizontal system). A railway wagon with a rotatable low and flat loading floor for bimodal transporting will be presented in this paper. Such a structure can be used for transporting various types of vehicles, for example, tractors, trucks, trailers, semitrailers, cargo containers. The railway wagon allows quick and convenient loading/unloading of vehicles and containers (without cranes), no platform infrastructure is required, instead of hardened, flat, surface; no need for hubs, terminals or special logistics; each wagon can be operated separately. It is possible to transport vehicles of 4m height and 36 tons mass on a GB1 gauge. The railway wagon comprises a body having end portions mounted on the standard two-axis bogies and a middle portion recessed with respect to the end portions along recess walls, a loading floor horizontally rotatable above the body. The loading floor is rotated by a pair of linear actuators, connected pivotally at each longitudinal side of the body to the longitudinal side edge of the body and to the middle of the corresponding longitudinal side edge of the loading floor. By dint of supporting the loading floor on guides and stabilizing it with locking pins, the wagon keeps a stable and rigid configuration during the transport. The loading floor is further supported on the rollers. The wagon may further comprise stabilizers mounted under the end portions of the body and configured to support the body on rails in the loading configuration.

*Keywords: Intermodal transport, railway wagon with a rotatable platform for transport of semitrailers, numerical FE analysis*

### 1 Introduction

Application of a set of special railway wagons for combined transport [3] benefits in the following areas: reducing of trucks transit time, reducing traffic on the roads reducing harmfulness of the influence on natural environment and many others. There hasn't been implemented a system to combined transport in our country so far. In European railway transport in recent years, there have been implemented combined systems based on horizontal or vertical reloading or others systems. These systems require developed reloading terminals equipped with, for example, vertical reloading devices of accurate load capacity or other expensive and complicated devices enabling loading and unloading activities.

The latest solution, developed in Europe in recent years, is the system of transportation of TIR type trucks by railway developed by French company MODA LOHR [5]. This system requires an extended infrastructure, especially, railway platforms as well as proper maintenance of the

platform devices, particularly in winter conditions. Figure 1 presents new intermodal systems developed by above mentioned French company and MEGASWING wagon built by Swedish company Kockums Industrier [6]. MEGASWING wagon is equipped with a low-loader rotating platform, which is rotated in respect to an asymmetrically located rotating junction, placed at the rear part of the wagon over its 'over-bogie' part. The other end of the moving platform, shifted outside the outline of the wagon, is equipped with a special running mechanism cooperating with overhanging arms stabilized by hydraulic supports on the surface of the reloading railway platform ramp.



**Figure 1** Wagons for trucks semitrailers transportation developed by French company MODA LOHR and MEGASWING developed by Swedish company Kockums Industrier [5, 6].

The wagon with a rotatable platform for combined transport, proposed by Military University of Technology (MUT), enables easy and fast autonomic loading followed by transport and autonomic unloading of TIR type trucks without the need of investment into development of additional infrastructure. Fundamental assumptions, the essence of a constructional solution of the wagon with a low-loader rotatable platform for combined transport were described in the paper. A technology demonstrator and selected results of simulation tests of such a wagon were also presented.

## 2 Idea of a special railway wagon with a rotatable platform for intermodal transport

A railway wagon with a rotatable, low and flat loading floor was presented in the paper. Such a structure can be used for transporting various types of vehicles, for example, tractors, trucks, trailers, semitrailers, cargo containers. The railway wagon allows quick and convenient loading and unloading of vehicles and containers (no cranes needed), self loading and unloading; no platform infrastructure is required, instead of hardened, flat, surface; no need for hubs, terminals or special logistics; each wagon can be operated separately. The developed methodology of examination of such a wagon structure enables its implementation both at the stage of the design and during tests on already exploited or renovated constructions.

### 2.1 Initial constructional assumptions

The concept of a new type wagon–platform in the below described tests meets the following initial constructional assumptions:

- outer dimensions of a wagon–platform result from DB1 gauge and dimensions of a basic semitrailer of 36 t weight, which was assumed for constructional works,

- platform is supported by two typical biaxial railway bogies,
- frame–support is equipped with over–bogie parts and a lowered bottom plate for building–up the moving body of the wagon,
- rotatable part of the wagon–platform enables an independent entry of the set of tractor/ towing vehicle and semitrailer from the one side and exit from the other side (the arterial body of the wagon),
- motion of the rotatable part is developed by two horizontal hydraulic actuators located in tailboards of the wagon body. The motion is implemented in respect to the central junction connected to the wagon frame–support on the lowered bottom of the frame,
- rotating junction is not subjected to extensive loads, either during transit or during loading/ unloading,
- during loading, in order to stabilize the platform, a bottom plate of the wagon frame will be supported on the heads of rails on the additional hydraulically controlled supports,
- during transport, the tailboards of the rotating part will be connected to the over–bogie part with the locks operating as the pin joints with two shear planes. The locks will be also hydraulically controlled,
- at the ends of the rotating part of the wagon body, there will be located rolls enabling its moving on the railway platform and simultaneously constituting a support of the rotating platform in the process of loading/unloading.

## 2.2 Structure of a new type wagon–platform

The innovative system of TIR type trucks railway transport proposed by MUT is schematically presented in Figure 2.

The proposed wagon for combined transport is built of a rotatable platform (3) – Fig. 4, which is rotated in respect to a rotating junction (4) placed in the central part of the floor plate of the wagon chassis (9) with the use of two hydraulic actuators (5 and 6) fixed in the platform tailboard and leading tracks mounted to over–bogie parts of the wagon chassis (7).

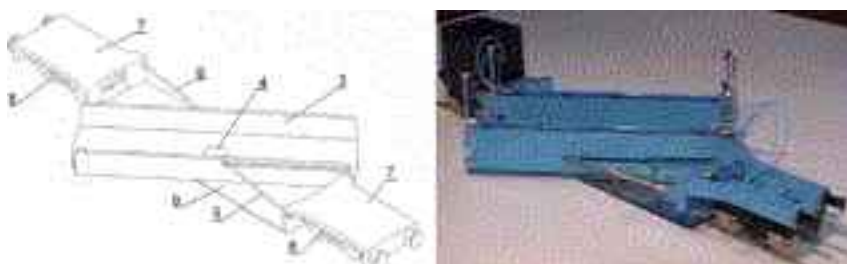

**Figure 2** Scheme and 1:14 scale model of the special railway wagon with a rotatable platform for transport of TIR–type semitrailers.

The wagon is also equipped with an openwork over–bogie carrying structure (7) located over the carriageable bogies (8) at the both ends of the chassis. The wagon chassis is equipped with supporters used for stiffening the construction during loading and unloading. The moving platform of the wagon is equipped with a group of special retaining tools, so called rolls, installed in the area of its ends, constituting its additional support during the rotation and enabling the free rotation of the platform in respect to the bottom plate of the wagon as well as in respect to the railway platform plate during loading and unloading. During these operations, there are also applied additional supports of the plate of the wagon chassis (9) resting on the heads of the rails. In the transport position, the rotating platform of the wagon for combined transport is firmly mounted on the over–bogie part with the use of special buckles with locking pivots (Figure 3).

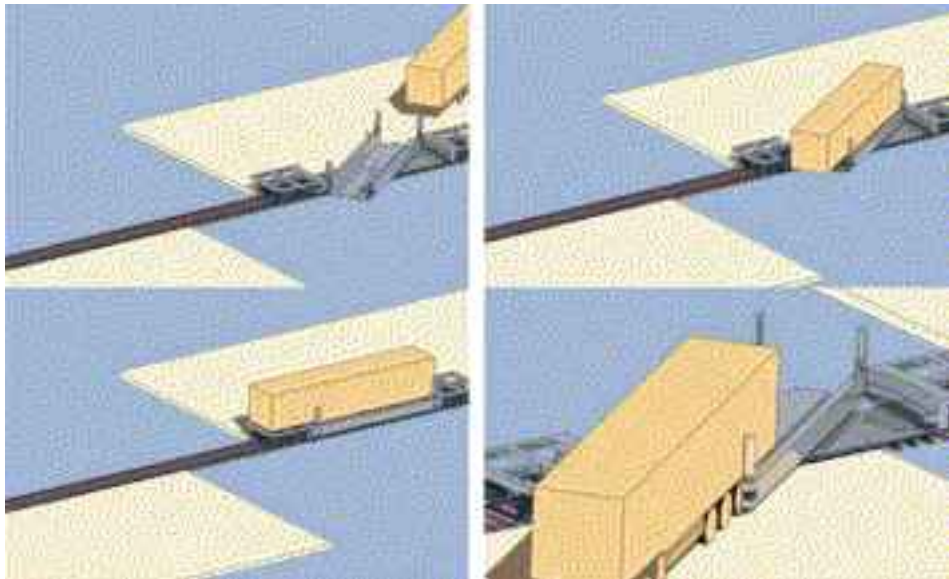

**Figure 3** Geometrical model of the special railway wagon with a rotatable platform – view of four vertical pin joint type locks and a part of the wagon structure prepared for loading and unloading operations.

The standard carriageable bogies, selected on the base of producers catalogues for combined transport, are applied in the proposed wagon. Dependently on the applied bogies, the wagon can be used also in broad-gauge traction.

Applying of the special locks connecting the rotating part of the body–platform with over-bogie parts of the frame–support of the wagon is of significant importance for accurate working of such a solution. Figure 3 schematically presents pin joint type locks with a hydraulic drive. Such locks inactivate the rotatable platform of the wagon body in the transportation position and assure accurate stiffness of such a system.

Figure 4 presents selected views from the animation explaining the procedure of preparing, loading and unloading of a semitrailer of a truck with a rotatable platform of the body.



**Figure 4** Selected animations of loading and unloading operations for the wagon with a rotatable platform.

### 2.3 Main features of the special railway wagon with a rotatable platform

In relation to presently utilized construction of such a type, the presented wagon's advantages are as follows;

- applying of repeatable wagons—platforms with an automatic rotating body for fast, safe and easy loading and unloading of trucks,
- constructional dimensions of the wagon with the load in the form of a semitrailer up to 4 m meet GB1 gauge, with the special consideration to 130 mm height over the rail head,
- applying of repeatable reloading railway platforms in the form of a system of repeatable segments for quick, easy and safe loading and unloading of trucks without additional crane devices,
- relatively simple and cheap infrastructure of the proposed system,
- enabling of cheap, ecological and safe transport of truck tractors with a semitrailer with a total length of 17,
- low exploitation costs of such a system.

## 3 Numerical tests

The object of the presented paper is selected problems of numerical analysis of strength of a constructional solution for a wagon with a rotating platform subjected to the influence of standard loads. The calculations were carried out on the basis of PN-EN 12663 standard [1]. There were discussed the selected results of numerical tests of constructional subsystems obtained in the considered version of the wagon for combined transports.

### 3.1 FE model of the special railway wagon

Taking into consideration the character of the designed wagon, it was assumed that correct mapping of the construction is possible only when all the subsystems are simultaneously subjected to the analysis considering boundary conditions resulting from their cooperation. Due to the nonlinear character of the mapped cooperation of wagon subsystems, including contact phenomena, MSC.Marc [4] software was selected for calculations.

The model of the presented constructional version of the wagon with a rotating platform consists of 93000 nodes and 83000 elements. Figure 5 presents an FE model with all essential constructional subsystems of the wagon considered.



**Figure 5** Wagon FE model – general view and model of boundary conditions (constraints and loads).

In a numerical model, there was applied a contact algorithm for both mapping the cooperation of particular subsystems of the wagon and connecting the layer elements with solid elements. For this purpose, a 'Glue' type contact was applied [2, 4]. The same type of contact

('glue' type) was defined between a pivot and a rotating platform and between a pivot and a frame and a chassis of the wagon.

It should be noted that such connection of different kinds of elements does not allow exact calculation of stresses in the area of connecting. In such a case, the only way to exactly determine stresses is a global–local analysis [2], i.e., constructing individual detailed models of connections and their analysis taking into consideration the results obtained from a global model of a complete structure.

### 3.2 Numerical results

Discrete FE models of the wagon with a rotating platform, discussed above, were applied and numerical analyses were carried out with the use of a finite element method (FEM). The interaction of the load was defined as sets of concentrated forces acting in the regions of pressure of the semitrailers wheels. Basic values of forces and an application region were assumed on the basis of the triplexial semitrailers with a maximum load of the total mass of 36 tons. In some variants of the loading, inertial forces were also acting on the platform. For the particular cases of loading, the values of forces were scaled according to standard requirements [1]. The following cases of numerical analysis are developed:

- variant I – the case of compression the wagon in the axis of buffers with force 2MN,
- variant II – the case of loading with own mass and mass of load increased by coefficient equal to 1.95,
- variant III – the case of loading with both own and load masses at simultaneous compression with 2MN force in the axis of bumpers,
- variant IV – the case of loading with both own and load masses in the unloading position.

Figure 6 presents the selected results in the form of maps of displacements and reduced stresses HMM corresponding to the case of numerical tests defined according to a standard [2].

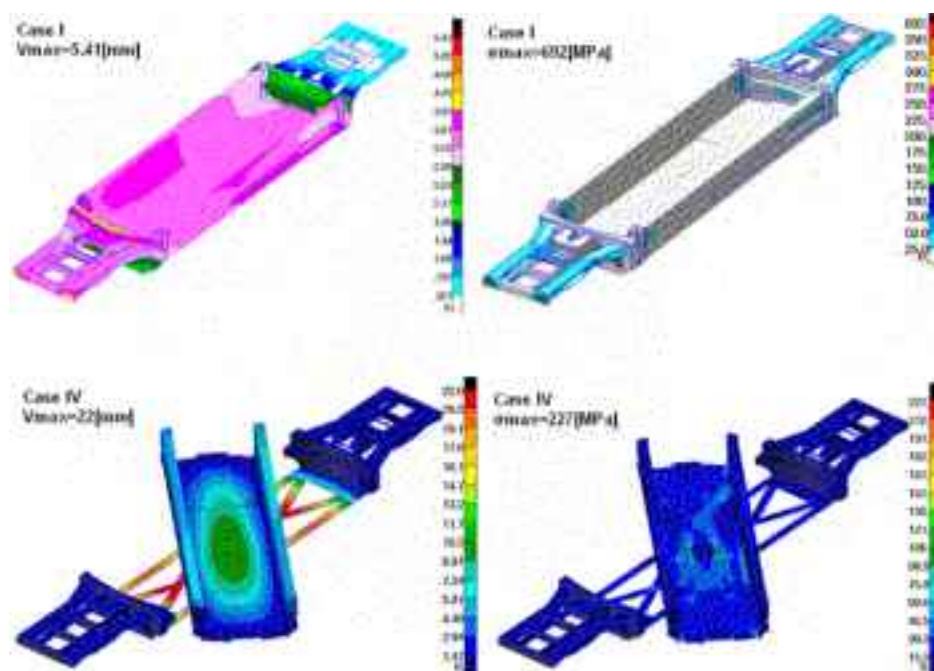

Figure 6 Case I and IV – selected results in the form of maps of displacements and reduced HMM stresses.

## 4 Summary

The results of analysis carried out in variant I show that the pivots locks of buckles connecting a rotating platform with the wagon frame (over-bogie parts of the wagon chassis) are the most strained region in the model. The maximum of stresses occur locally at the places necessary model simplifications were possible to influence accumulation of stresses. It mainly concerns small areas of mounting of the tailboard buckles with the support and parts of pivotal locks. In variant IV, there was examined the strength in the wagon configuration occurring after unlocking of pivotal buckles between the tailboards of a rotating platform and an over-bogie part of the wagon frame as well as after rotating the platform to the loading/unloading position. In this case of loading, there were applied additional boundary conditions considering the fact of the rotating platform leaning against the railway platform (through the rolls mounted under the utmost edges of the platform) and acting of additional supports founded hydraulically onto the rails under the wagon support during the loading – unloading operations. On the basis of the carried out examinations, it can be concluded that the highest values of contact stresses occur in the slight areas of mounting of the buckles connecting the tailboards of the moving platform with the over-bogie part of the wagon support. Unfortunately, these concentrations occur in the areas where very accurate geometry mapping and considering even slight constructional details is required. It results in a significant increase of dimensions of discrete models and extension of calculation duration time.

The work is financed by National Center of Research and Development – PBR R10 0023 06/2009

Presented constructional solution is protected by European patent application – EP 10461528

## References

- [1] PN-EN 12663: Railway applications - Structural requirements of railway vehicle bodies, Warsaw, 2002.
- [2] Zienkiewicz o. c, Taylor R.L.: The finite element method. V-edition, McGraw-Hill, London, 2000.
- [3] Kwasniowski S., Nowakowski T., Zajac M.: Transport intermodalny w sieciach logistycznych, Oficyna Wydawnicza Politechniki Wrocławskiej, 2008 (in polish)
- [4] MSC.Patran/Marc, Manual, MSC, 2005.
- [5] Rail-road. [www.lohr.fr/index\\_gb.htm](http://www.lohr.fr/index_gb.htm), LOHR 11.2009.
- [6] Intermodal wagons. MEGASWING. [www.kockumsindustrier.se/en-us/start/](http://www.kockumsindustrier.se/en-us/start/), 05.09.2011.





## 18 TRAFFIC SAFETY



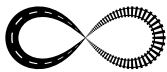

## SAFETY MEASURES ON RAIL AND ROAD ENGINEERING STRUCTURES – A COMPARATIVE ASSESSMENT

Christos Pyrgidis, Fotini Kehagia

*Civil Engineering Department, Aristotle University of Thessaloniki, Greece*

### Abstract

Safety is one of the key parameters defining the service level of a transportation system. A good safety level makes the system more competitive and attractive to the users and thus contributes to the increase of its potential patronage. Safety is evaluated by the number of incidents that take place during a certain time period which have negative effects on the track, on the rolling stock, on the passengers, on the cargo and on the environment. Incidents occur in all three components of the transportation system (permanent way, civil engineering structures and operational facilities). In particular, the accidents taking place on engineering structures have the worst consequences, including large numbers of fatalities, due to the difficult rescue and escape conditions (on bridges, in tunnels etc) and high cost of the applied mitigation measures. This paper focuses on the rail and road engineering structures applied in high-speed rail and highway networks. In this context, the incidents and their causes are examined and explained. Moreover, the mitigation measures used in order to increase the safety level are recorded and evaluated. The engineering structures under examination are a) tunnels, b) bridges, c) road overpasses, d) embankments, e) cuttings. The approach is based on the comparison between the two transport modes through their engineering structures. The results highlight significant differences in safety measures implemented to the two transport modes due to their different technical and operational characteristics. However, significant similarities are also apparent as the same fundamental safety principles govern rail and road projects. The results of this paper could form the basis of the drawing up of safety recommendations addressing the planning, design, construction, operation, inspection and maintenance, of engineering structures in the rail and road infrastructure.

*Keywords: road safety, railway safety, road engineering structures, rail engineering structures, safety measures*

### 1 Introduction

This paper deals with the safety aspects of civil engineering structures applied in high-speed railways and highways networks. In particular the following structures are examined: bridges, tunnels, road overpasses, embankments and cuttings. Incidents taking place in these structures are identified and mitigation measures implemented to increase their level of safety are presented and analyzed. The whole approach is based on a per structure category comparison between the above two transport systems. The results of this paper highlight significant differences in safety measures adopted for the two systems due to their different technical and operational characteristics. However, similarities are also apparent as the same fundamental safety principles govern rail and road projects. This fact is the main motivating factor initiating this paper. The findings of this paper could form the basis of the drawing up of safety recommen-

dations addressing the planning, design, construction, operation, inspection and maintenance, of engineering structures in rail and road infrastructure.

## 2 The safety parameter in rail and road civil engineering structures

Engineering structures in rail and road transportation systems are taken to be all the constructions built—in along the track or the road aiming to achieve their layout insertion into areas with difficult topography and sensitive environment. They must ensure the safe movement of trains and road vehicles and they must be harmoniously integrated in the environment.

The safety provided by a transportation system is evaluated by the number of specific incidents (derailments, collisions, etc) that take place during a certain time period (for example a year) which have specific negative effects on the track, on the rolling stock, on the passengers, on the cargos and on the environment.[1] According to another definition, the safety of a transportation system is the assurance that the provided risk level (combination of frequency and severity of incident factors) is not characterised as 'non-permissible'.[2]

Measures taken by the system operator to reduce the likelihood of incidents are characterised as preventive measures. Measures aiming at reducing the consequences of the incidents (measures to reduce the consequences) so that the actions taken following the incident are performed rationally (escape and rescue measures), are characterised as management measures. In the engineering structures virtually all the incidents taking place on the 'open' track can also occur. Table 1 shows the incidents which occur and require special handling for the two transport systems under examination for each individual engineering work.

As a transportation system, the railway differs from the road vis-à-vis in three components, that is, infrastructure, rolling stock and operation.[3] As a consequence, there are marked differences in terms of safety between the road vehicle and the train concerning both the characteristics of the incidents (type, severity) as well as the safety measures taken for the prevention and management of incidents. .

**Table 1** Incidents on rail and road engineering structures requiring special management

Engineering structure	Railway track	Highway
<b>Bridges</b>	Train derailment and falling from the bridge (for various reasons) Pedestrians dragged along by rolling stock Train derailment due to strong cross winds and falling from the bridge Workers dragged along by rolling stock (due to aerodynamic phenomena) Immobilisation of a train on a bridge	Road vehicle falling from the bridge (for various reasons) Pedestrians dragged along by road vehicle Road vehicle hits a parapet due to different reasons (poor driving behaviour, misreading of road design and layout)
<b>Tunnels</b>	Fires or emission of toxic gases and smoke inside the tunnels Work accidents Passengers' discomfort in terms of noise Shattering of window pane in train carriage Immobilisation of a train in a tunnel	Fires or emission of toxic gases and smoke inside the tunnels Work accidents Collision of road vehicles Loss of road vehicle control for various reasons (poor driving behaviour, misreading of road design and layout)

<b>Road Over passes</b>	Loss of road vehicle control and falling from the road to the track Object falls from the road to the track	Loss of road vehicle control and falling from the road overpasses to the highway
<b>Embankments</b>	Train derailment due to strong cross winds and falling from the embankment Appearance of non permitted limits of track defects due to embankment subsidence – Train derailment Immobilisation of a train on a high embankment	Loss of road vehicle control and running off the road Collision of road vehicles with fixed obstacles
<b>Cuttings</b>	Collision between train and obstacle on the track Accident due to landslide Rock fall Immobilisation of a train on deep cuttings	Collision between road vehicle and obstacle on the road Accident due to landslide Rockfall Collision of road vehicles with fixed obstacles

Indicatively:

- The railway has only one degree of freedom. Due to the impossibility of a train to perform manoeuvres while moving, braking is the only option when faced with the risk of two trains colliding or a train crashing into an obstacle. However, during braking, as a result of the low adherence between wheel and rail (steel/steel contact) and the greater braking load, the braking distance of a train is much greater than that of a road vehicle. Given this fact, since braking seldom prevents a collision, it is of great importance that the railway can 'prevent' such accidents by taking those measures necessary in order to avoid collision conditions.
- Trains possess operational and constructional features which increase the aerodynamic phenomena as they move (high speed, great length, large frontal cross section). These phenomena may have negative consequences for rolling stock, passengers, system users who are on the platforms and staff working near the track. At the same time, due to the train's large lateral surface, it receives greater transversal wind loading, thereby making it more susceptible to being overturned as a result of cross winds.
- The railway moves along the railway track which, because of its construction (rails/sleepers/ballast) cannot be used by the usual road transport. Also, in many instances the layout of the track is integrated into the topography of the ground which is inaccessible to road transport. Given this fact, if a train is immobilised on the track, either due to a fault or an accident, the evacuation of passengers from the site of the incident and the provision of first aid is a particularly challenging operation.
- The rolling surface of roads in contrast to that of the railway track is impermeable to water, meaning that driving in icy conditions or following heavy rainfall is hazardous (risk of sliding or aquaplaning).

In particular, in regard to engineering structures, the two systems, railway and road, differ in terms of design, construction, operation and maintenance.[3]

As far as design is concerned, the differences are generally to be found in the alignment, loading and typical cross-section of the structures. The railway requires greater horizontal curvature alignment and smaller longitudinal slopes. The static loads used for dimensioning of the structures are much greater, while special attention is needed for dynamic loads which might produce resonance phenomena.

Great importance is placed on differential settlements as any exceeding of the allowed limits will lead to derailments. The track gauge of a double railway track has less than a 2X3 road (ratio of

1:3) while the clearance gauge on the railway is greater, particularly in the case of electrification because of the traction system installations.

The most significant differences as far as the operation is concerned relate to the aerodynamic impact, the ground-borne noise and vibrations and acoustic nuisance. Problems concerning aerodynamics, particularly in high-speed tunnels, impact on passengers' health (sudden changes in pressure) can create feelings of insecurity in those living adjacent to the track. Vibrations are felt in the embankments resting on loose and soft soil, which could affect the nearby buildings. Lastly, railway engineering structures require greater maintenance in comparison with those of the road due to increased static and dynamic loads and the very small room for track defects.

### 3 Safety on bridges

#### 3.1 Railway bridges

The main cause of accidents on railway bridges is cross-wind. It has been proven that when the speed of 25 m/s is exceeded, the transversal and vertical acceleration of the bridge body increases dangerously, thus reducing the safety of its passage. The thicker the bridge body, the greater the transversal force coefficient is. In the event of an untoward incident (collision of trains, derailment, immobilisation of train on a bridge) due to construction of the specific structure above natural ground level or above a water hazard, together with the narrowness of the space, increases the severity of the incident while at the same time making the evacuation of the passengers and access of the rescue services more difficult. In all cases the placement of anti-derailment protective checkrails along the track should be envisaged.

#### 3.2 Road bridges

Road accidents at bridge locations are common and usually very serious in nature. The characteristics of the design of the road alignment and cross-sections providing the safe sight distance affect the appearance of the incidents. The installation of adequate safety barriers on the approach holds the vehicles on the road.

Table 2 presents the safety measures used on bridges for the two systems in question.

**Table 2** Mitigation measures implemented on railway and road bridges

Category of measures	Rail bridges	Road bridges
<b>Preventive measures</b>	Wind barriers and drapes Harmonic buffers Anemometers Footways for workers	Signing and road markings Pedestrian facilities Footways for workers
<b>Measures to reduce the consequences</b>	Anti-derailment protective checkrails	Safety parapets and barriers
<b>Escape and rescue measures</b>	Footways for pedestrians Construction of steps for evacuation to safe place Safety Manholes	Footways for pedestrians

## 4 Safety in tunnels

### 4.1 Railway tunnels

Accidents common on the rest of the railway line such as collisions on level crossings, collisions with impediments, derailments caused by wind or landside cannot occur in tunnels. The most serious accidents to have occurred inside tunnels have involved fire, the release of smoke and toxic gasses. Additional problems are created by increased aerodynamic pressures or reduced ventilation (in the case of diesel locomotives). In tunnels servicing high-speed trains, a sudden reduction in the passenger's acoustic comfort and cracking of window panes may be experienced due to the sudden change in pressures. In cases of such incidents (train collisions, fire, immobilisation of the train inside a tunnel etc), due to the construction the specific structure below ground, the severity of consequences increases especially in long tunnels as does the need for fast evacuation from the incident site, while access for the rescue services becomes more problematic.

Two construction types for railway tunnels have prevailed internationally: the standard single-track tunnel and the single tube double-track tunnel. The main advantage of the twin-tube is zero collisions with passing trains (and the avoidance of aerodynamic problems occurring from the crossing of trains moving in opposite directions) and the high degree of protection in case of a fire event. The single-tube tunnel has respectively the major advantage of lower construction costs and clearly reduced aerodynamic problems

### 4.2 Road tunnels

Road accidents in tunnels are characterized by their importance in human, economic and cultural terms. Special consideration has to be given to safety in the design of the horizontal and vertical alignment of a tunnel because these parameters have a significant influence on the probability and severity of accidents. Safety measures should enable people involved in incidents to rescue themselves, allow road users to act immediately so as to prevent more serious consequences and ensure that emergency services can act effectively and protect the environment as well as limit material damage. However, the probability of an accident occurring and of being injured is lower in tunnels than on open stretches of roads, but the severity of injuries is significantly higher. [4]

Table 3 presents the safety measures used in tunnels for the two systems in question.

## 5 Safety on road overpasses

### 5.1 Passage of the rail track under a road bridge

Accidents on road overpasses– railway underpasses usually occur as a result of objects falling from road bridges.

### 5.2 Passage of highway vehicles under a road bridge

Road accidents on road underpasses are due to loss of road vehicle control and falling from the road bridge. The installation of adequate safety barriers, on the approach, holds the vehicles on the road. However, when the road overpasses supporting columns have no protection it results in their crashing onto the trains.

Table 4 presents the safety measures used on road overpasses for the two systems in question.



**Table 3** Mitigation measures implemented in railway and road tunnels

Category of measures	Rail tunnels	Road tunnels
<b>Preventive measures</b>	Control centre for surveillance of tunnels Hot-box detection devices placed at tunnel entrance Avoidance of turnovers and crossings in tunnels	Control centre for surveillance of tunnels Video monitoring systems Road signs and panels Special lighting
<b>Measures to reduce the consequences</b>	Fire resistant structures Automatic fire, smoke and toxic gas detection systems, Installation of fire extinguishing system Ventilation system to control heat and smoke Water supply Emergency power supply Measures to reduce aerodynamic problems	Fire resistant structures Automatic fire, smoke and toxic gas detection systems, Installation of fire extinguishing system Ventilation system to control heat and smoke Water supply Emergency power supply Ventilation system to control pollutants Drainage system for flammable and toxic liquids Equipment for emergency closing of tunnel
<b>Escape and rescue measures</b>	Escape routes and emergency exits Safety and evacuation lighting Emergency exits leading to ground surface Emergency contacts Auxiliary tunnel for single-tube, double-track tunnel. Cross connections between tunnel tubes Staff refuge area	Escape routes and emergency exits Safety and evacuation lighting Emergency exits leading to ground surface Emergency contacts Cross connections between tunnel tubes

**Table 4** Mitigation measures implemented on road over-passes

Category of measures	Rail underpasses	Road underpasses
<b>Preventive measures</b>	Proper design of alignment and cross-section of the road. Pedestrian facilities on the road bridge. Signing and road markings on the road.	Proper design of alignment and cross-section of the road Pedestrian facilities on the road bridge Signing and road markings on the road.
<b>Measures to reduce the consequences</b>	Safety parapets and barriers Protective wall for road bridge supporting columns  Horizontal protective nets on the road bridge	Safety parapets and barriers

## 6 Safety on embankments

### 6.1 Railway embankments

In the construction of embankments for engineering structures, particular attention must be paid to their height (lower height relative to road embankments) and to their compactness so as to avoid subsidence and by extension the geometrical defects of the track panel. When subsidence of an embankment does occur, the difference in elevation which may be produced in the two rails on the track becomes particularly hazardous for train movements and certainly detrimental to the operation of the system.

### 6.2 Road embankments

The terrain along the roadside may affect the number of accidents and the severity of injuries. Steep slopes increase the probability of a vehicle falling from the embankment in the event of running off the road. Moreover, permanent obstacles close to the road can increase the number of accidents and leave a smaller margin for regaining vehicle control when it has been lost.[5] Table 5 presents the safety measures used on embankments for the two systems in question.

Table 5 Mitigation measures implemented on rail and road embankments

Category of measures	Rail embankments	Road embankments
<b>Preventive measures</b>	Protection from groundwater and rain water Strengthening of embankment foundation soil Monitoring of movements by optic fibres Wind barriers and anemometers	Proper design of alignment and cross-section Signing and road markings Flattening of side slopes Removal of fixed obstacles Increasing distance between the edge of the road and fixed obstacles
<b>Measures to reduce the consequences</b>		Safety parapets and barriers
<b>Escape and rescue measures</b>	Separating of the railway track into 'safety zones'. Linking up of 'safety zones' with road network. Construction of steps for evacuation to safe areas	

## 7 Safety on cuttings

### 7.1 Railway cuttings

The most common accidents occurring at cuttings are caused by rocks falling on the track or by landslips. When rocks fall onto the track, there is a high risk of the train colliding with the obstacle on the track, since it cannot be avoided by braking, while usually falling rocks are not identified in time. Often such collisions can lead to derailment. A high water table and poor drainage contribute to the breaking up of the superstructure and substructure of the track, thus particular attention must be paid to them. **Road cuttings**

Road crossings of mountainous terrain in zones with steep gradient may provoke rockfall or a landslide. Sliding soil masses or sudden displacement or collapsing rocks reduce the safety and increase the need of operational expenses. Controlled release of landslides or periodic closure of roads may be used as preventive measures.[5]

Table 6 presents the safety measures used on cuttings for the two systems in question.

**Table 6** Mitigation measures implemented on rail and road cuttings

Category of measures	Rail cuttings	Road cuttings
<b>Preventive measures</b>	Protection from rockfall (fences and catch nets, protective gullies, rock-trap ditches, retention walls) Protection against slope slip  Track guard presence	Protection from rockfall (fences and catch nets, protective gullies, rock-trap ditches, retention walls) Protection against slope slip
<b>Measures to reduce the consequences</b>		Removal of fixed obstacles Increasing distance between the edge of the road and fixed obstacles
<b>Escape and rescue measures</b>	Separating of the railway track into 'safety zones'. Linking up of 'safety zones' with road network. Construction of steps for evacuation to safe areas	

## 8 Conclusions

Incidents which take place in both engineering structures of high-speed railway lines and highways have many similarities as already shown but also a number of significant differences. The differences result from different technical and operational characteristics of the two transport systems, and are related both to the kind of incidents taking place and to the measures used to deal with them. In Table 1, incidents which differ between the two systems are shown in italics, while those which are the same appear in regular characters. Tables 2 to 6 present the measures used to combat the incidents. More analytically:

On the railway

- Embankments must have the lowest height possible and the greatest possible degree of compactness
- Horizontal protective netting must be placed on road overpasses
- Provision must be made for appropriately designed steps on high embankments, deep cuttings and bridges for the evacuation of passengers to safe areas in the case where a train is immobilised on the track
- Falling rocks at cuttings must be avoided at all costs while such events must be identified and managed at the earliest possible time.

On highways

- Lighting in tunnels needs to be designed especially for the purpose
- Barriers must be placed along all engineering structures
- Good design and road signs are particularly important on all engineering structures

## References

- [1] C.Pyrgidis, L. Kotoulas, 'An integrated system for the recording and monitoring of railways incidents', presentation to the 7th World Congress in Railway Research (WCR), Montreal, 6-8/6/2006, Congress Proceedings.
- [2] European Standard, 'Railway Applications-The specification and demonstration of R.A.M.S', European Committee for Electro technical Standardization, (June 1997)
- [3] CH.PYRGIDIS, A.MOURATIDIS,S.TZAVARA , 'Railway structures— Peculiarities /differences in relation with road structures', 8th International Congress Railway Engineering –2005, 29-30/06/05, London
- [4] Directive 2004/54/EC of the European Parliament on minimum safety requirements for tunnels in the Trans-European Road Network
- [5] Elvik R. Vaa T.: The Handbook of road safety measures, Elsevier, 2004.

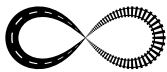

## CONTROL SYSTEM FOR TRAINS IN MOVEMENT

Dobrinka Atmadzhova<sup>1</sup>, Emil Dimitrov<sup>2</sup>, Nencho Nenov<sup>1</sup>

*1 Todor Kableshkov University of Transport, Sofia, Bulgaria*

*2 Technical University of Sofia, Bulgaria*

### Abstract

Bulgaria's accession to the European transport system and its strategic geographical location has imposed the necessity of a high-level operational reliability in the rail sector. With particular urgency and profoundness, in relation to the commitments stipulated in the regulations of the European Parliament (Directive 2001/14/EC on the allocation of railway infrastructure capacity and the levying of charges for the use of railway infrastructure and safety certification and EN 14363: 2005 E 'Railway applications – Testing for the acceptance of running characteristics of railway vehicles – Testing of running behaviour and stationary tests'), the problem to develop systems for monitoring on the national railway infrastructure has become a priority. The mandatory implementation of control systems for trains in movement should create conditions for continuous objective monitoring on the transport process. It will result in providing traffic safety and preventing accidents as well as in a number of other effects such as increased economic efficiency in operation and maintenance of infrastructure and rolling stock, allocation of railway infrastructure capacity and collection of charges, etc. This paper developed by scientists working in the field of diagnostic equipment to determine the technical condition of the most important vehicle undercarriage elements is intended to interested public. A detailed study and comparative analysis of the systems used by leading railway administrations have been made. The basic principles of the construction are examined and Check PointBG functions related to its regional purpose are determined. Alternative methods have been proposed, which concern the nature of vehicle–track interaction, hence traffic safety. A number of diagrams experimentally established under conditions similar to real operational environment are presented. Some peculiarities in measurement defining the conditions necessary to model the Bulgarian control system of trains in movement are shown.

*Keywords: movement of train, control systems for trains in movement*

## 1 Introduction

### 1.1 Effects of introducing a system for control of trains in movement

The most important benefits of development and implementation of the system of technical, economic and social nature and can be summarized as follows:

- ensuring a high level of rail system operational reliability;
- increasing economic efficiency in infrastructure and rolling stock operation and maintenance;
- preventing failures and accidents;
- allocation of railway infrastructure capacity;
- charging for using the railway infrastructure;
- certification for train traffic safety;
- ride comfort, etc.

## 1.2 European regulations

- Directive 2001/14/EC on the allocation of railway infrastructure capacity and the levying of charges for the use of railway infrastructure and safety certification
- EN 14363:2005 E, 'Railway applications – Testing for the acceptance of running characteristics of railway vehicles – Testing of running behaviour and stationary tests', Brussels 2005

## 2 Advanced international experience

In Europe such systems are under development, implementation and operation by the railway administrations of Germany, Holland and Austria.

Example: In 2005 the infrastructure provider ProRail jointly with companies Baas R&D and NedTrain Consulting implemented the system Quo Vadis in the railway network of the Netherlands.

The system is designed for monitoring on the status of infrastructure and rolling stock. Its construction has been initiated by the entry of EU Directive EC 2001/14 into force. The system employs about 40 work points for the construction of which have been invested about 3.5 million EUR. It uses fibre optic technology as the measurement is guaranteed at speeds up to 40 km/h. The trains passing through the adjacent posts carry about 80% of the total passenger transport and about 96% of the freight transport in the country. The system provides information about the mass of the train, axle load, vehicle wheel condition, the speed and number of axles of the trains passed. The operation of all points is controlled remotely from a central post.

The system Quo Vadis registers the condition of wheels (reduces the costs of bandage/ tread grinding) and significantly decreases the number of overheated axle boxes (almost 90%). The information from the system component performing identification of rolling stock provides accurate data of the actual use of infrastructure and its occupation.

The data for 2005 showed that the trains running within the railway system are actually with a mass 16% bigger than estimated according to the train traffic schedule and about 1,6% of the axle passed are of load exceeding the permitted one of 22,5 t. The results obtained from the system can be used as a basis for developing draft amendments of route and track development to streamline operational and technical-economic indicators of the train traffic organization.

According to the data cited in European Railway Review [1], the annual economic effect of the system implementation is about 2 million EUR.



## 4.1 Recognition systems

The recognition system of trains by frequency sensors is shown in the figure 1.



Figure 1 RFID Recognition System

Features of the rail system RFID:

- immediate identification of the vehicle;
- long life cycle, low energy consumption;
- multifunctional applications (infrastructure, logistics and management);
- technology for all types of vehicles and speed of passing;
- not using external power;
- basis for innovative services;
- quick and inexpensive installation.

An example of train recognition system by intelligent optical sensors is shown in the figure 2.

Functions of the optical recognition system:

- reading the wagon (locomotive) number;
- imaging and comparison of the read numbers with database;
- video recording of passing;
- wagon data transfer (number, date and time);
- identifying images of dangerous characters;
- investigation of special vehicles.



Figure 2 Optical Recognition System

## 4.2 Measurement of the load of each wheel

The standards and regulations existing and being in force up to now are presented in table 2. The sensor for measurement of wheel load and the device for testing and calibration are presented in figures 3 and 4.

Table 2 Regulations for a wheel loading of rolling stock.

Standard	Parameters related to the force in rail-wheel contact			
	Force in rail-wheel contact	Force in rail-wheel contact	Weight in rail-wheel contact	Allowed maximum
EN 14013-1	$F_{\text{max}} = F_{\text{max}} \cdot 2 \cdot 2 \cdot 2$	$F_{\text{max}} = F_{\text{max}} \cdot 2 \cdot 2 \cdot 2$	$F_{\text{max}} = F_{\text{max}} \cdot 2 \cdot 2 \cdot 2$	
EN 14013-1	$F_{\text{max}} = F_{\text{max}} \cdot 2 \cdot 2 \cdot 2$	For loading wheel axle, regardless of axle number and location: $F_{\text{max}} = 42 \cdot E_{\text{min}} \cdot L \cdot 2 \cdot 2$ reduced axm. divided by 2		$F_{\text{max}} = F_{\text{max}} \cdot 2 \cdot 2 \cdot 2$
EN 14013-1	$F_{\text{max}} = F_{\text{max}} \cdot 2 \cdot 2 \cdot 2$	For loading wheel axle, regardless of axle number and location: $F_{\text{max}} = 42 \cdot E_{\text{min}} \cdot L \cdot 2 \cdot 2$		$F_{\text{max}} = F_{\text{max}} \cdot 2 \cdot 2 \cdot 2$
EN 14013-1		N/A		$F_{\text{max}} = F_{\text{max}} \cdot 2 \cdot 2 \cdot 2$

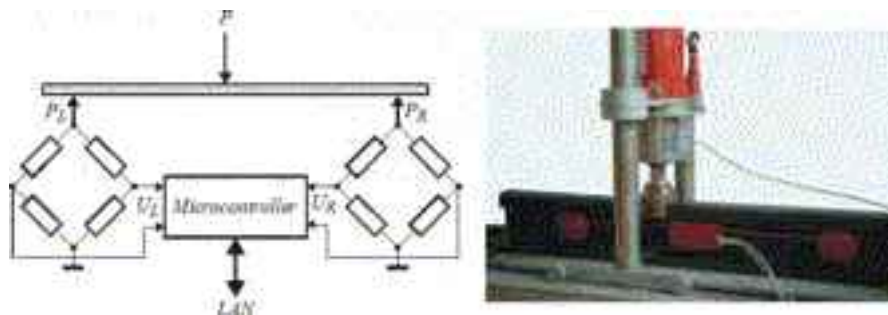

Figure 3 Sensor for measurement of wheel load and the device for testing and calibration

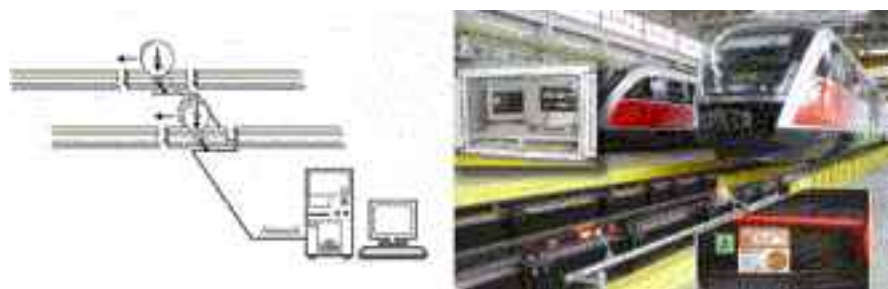

Figure 4 Principle of measurement and Device for measuring load of DMU and EMU Siemens



### 4.3 Detection of periodic deviations from circularity of the rolling surface

Figure 5 shows typical wheelflats / entrenchment (stratification) on the rolling surface of the wheel and a block diagram of the electronic measuring system.

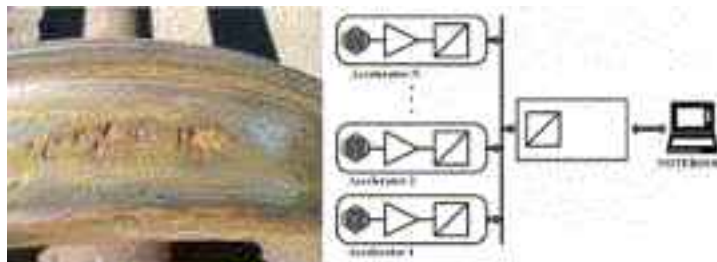

Figure 5 Wheelflats and Block scheme of the electronic system

The sensor unit is attached to the bottom ('foot') of the rail and measures the accelerations caused by the passing wheels with periodic deviations from circularity. The registered signals are processed by Wavelet–decomposition of the signal, replacing the classical decomposition in Fourier series.

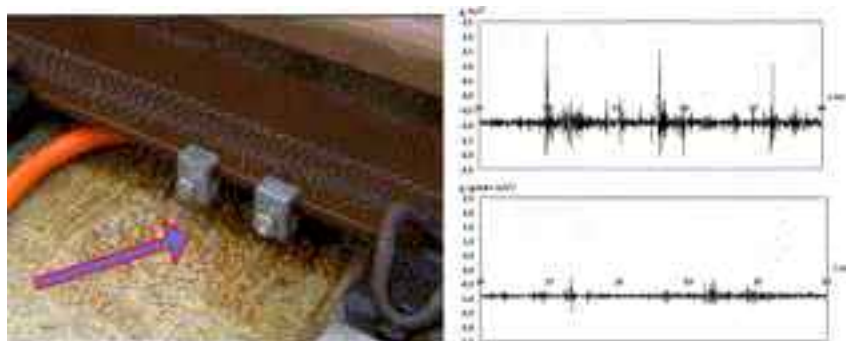

Figure 6 Sensor unit and signals with a faulty/properly operating wheel

### 4.4 Detection of temperature limit excess

Detection is achieved by thermal imaging cameras and processing and analyzing software. This subsystem monitors the excess of the limit values for temperatures of axle bearing assemblies, of the adhesion braking system friction surfaces, of the surfaces of tread profiles, etc.

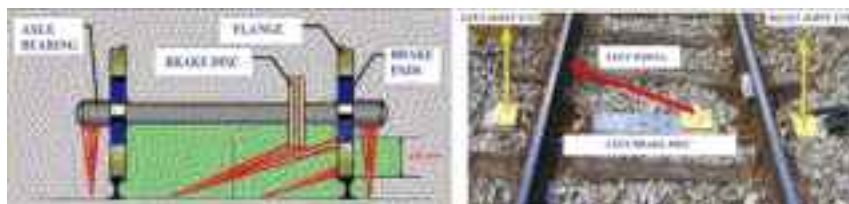

Figure 7 Principles of measurement and detection of overheating

#### 4.5 Telecommunication connection

The information from each local point of the systems enters the central server from where control activities are generated and entire diagnostics information is accumulated analyzed and summarized [6].

The second system component allows monitoring on the cargo location and condition of, transport service pricing (without influence of the human factor) and on this basis, payment between the shipper and transport operator and between the operator and infrastructure provider.

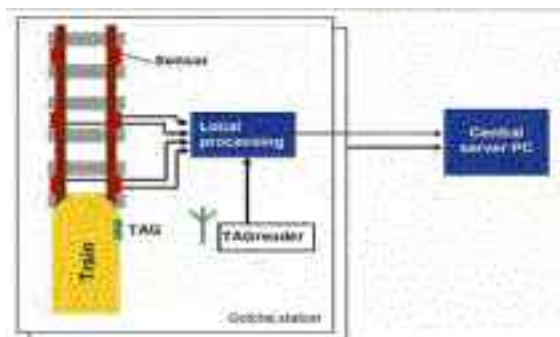

Figure 8 System for telecommunication connection with the central server

## 5 Conclusion

This paper has examined the main principles for building Check Point systems defining their main functions. It suggests alternative methods to control a set of parameters whose characteristics of changing are directly connected with the nature of 'vehicle-track' interaction, hence with traffic safety. A number of diagrams proved through experiments are presented and some peculiarities in the measurement philosophy defining the prerequisites for modelling the Bulgarian system of train control in movement are shown.

## References

- [1] European Railway Review, №3, p.80-86, 2005.
- [2] Mallab S., A wavelet tour of signal processing, Academic Press, 1999.
- [3] Lasca: Automatic monitoring of the running quality of railway vehicles, Railway Technical Review, 2/2007.
- [4] MATTILD – Laserwaage fuer die Messung von Radlasten und Flachstellen am fahrenden Zug, Signal + Draht ,1+2/2003.
- [5] [www.argos-systems.eu](http://www.argos-systems.eu).
- [6] [www.gotchamonitoringsystems.com](http://www.gotchamonitoringsystems.com).
- [7] [www.railbam.com.au](http://www.railbam.com.au).
- [8] [www.schenckprocess.com](http://www.schenckprocess.com).



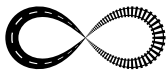

## ENSURING SAFETY OF OPERATION BY AUTOMATIC MEASUREMENT OF ROLLING STOCK WHEELS GEOMETRY

Janusz Madejski

*GRAW, Silesian University of Technology in Gliwice, Poland*

### Abstract

Safe rolling stock operation calls for objective and reliable monitoring of wheel wear which is an important factor affecting passengers' and cargo transportation safety. Wheel wear developing continuously during operation includes deterioration of the wheel flange cross sectional profile and reduction of wheels' diameters, which have to be analysed for all wheels in a bogie, and coach. Wheel profile and diameter have to be inspected regularly, as their uncontrolled change with time would pose threat to safety of train operation as, for instance flange angle and root radius are the variables that have a significant effect on the possibility of derailment. In any case change of the wheel profile may lead to the increased rolling contact fatigue which can have expensive and dangerous consequences. Another important issue is the out-of-roundness error, very important especially for the high-speed trains. The wheel wear process is more intensive than the track and turnouts degradation.

Polish fast train operator InterCity decided to monitor its entire fleet of coaches and the relevant measurement system was required, so the laser system was developed by GRAW (Poland) to measure automatically wheel sets on all coaches using the machine vision technology. The system has been designed to perform the automatic, contactless measurement and monitoring of flange height and thickness, Qr parameter, wheel diameters on rail vehicle wheel sets, as well as for bogie geometry control. Moreover, the system can identify coaches from their RFID tags, and based on the wheel history, it can recommend the pre-emptive maintenance operations. The paper presents the measurement system principle and measurement results, as well as the independent portable devices used to verify its readings.

*Keywords: tram, track, vibrations, urban areas, environmental protection*

### 1 Introduction

During wheelset operation, its wheels are subject to wear and when the worn profiles reach one of the limit values defined by international standards [1], the wheels have to be reprofiled. This continuous wear of the vehicles' wheels is an important factor affecting safety of train operation. The problem has to be analysed from two, conflicting sometimes, points of view: the impact of trains operation on the infrastructure condition, and the damage on vehicles caused by the infrastructure condition [2]. Having that in mind one has to analyse these factors affecting heavily the life cycle costs of the railway networks. The goals of many projects (like, e.g., AWARE – ReliABle Prediction of the WeAr of Railway WhEels) and new developments are finding the methods to reduce the operation and maintenance costs, by increasing the life cycle of both vehicles and tracks, however, with increasing the speed, safety and ride comfort of the trains [3].

Apart from the safety issues, economy is also becoming the increasingly important issue. It is known that some wheelsets may require reprofiling after only 80.000 km of service, while

others can safely operate for more than 400.000 km in similar conditions without need such maintenance procedure. It has to be also born in in mind that the railway wheels can be usually reprofiled not more than 3 or 4 times and that wheelset replacement is very expensive [3, 4]. One has to take into account also that the premature wheel wear usually results in the excessive wear of the rails condition deterioration. The rolling stock operators' losses include both the wheel reprofiling or wheelset replacement costs and also a cost resulting from the damage done to the permanent way, which they have to incur either as a penalty paid for the bad condition of wheels of their fleet, or by spending more money on the permanent way repairs should it be their property, like it happens for metro or some tram companies.

The process of the loss of relatively large (up to 5mm) pieces of metal from the wheel tread surface is caused by stresses generated by rolling contact of the wheel with the rail. To make the process more complex, the rolling contact stresses are always affected by other factors also. These other factors finally result in differentiation of the wheel surface damage by shelling (initiated by contact fatigue) and spalling (initiated by thermal cracking) [5].

Therefore the wheel wear developing during operation includes deterioration of cross sectional profile of the wheel flange, diameter reduction, and which is especially important – this reduction has to be analysed for all wheels in a bogie, and for both wheels of a wheelset. Another important issue is the out-of-roundness error, very important especially for the high-speed trains. This process is affected by track geometry and condition, as well as by such rolling stock operation characteristics like operation velocity, load, and overall technical condition of the coaches and locomotives. The wheel wear process is more intensive than the track and turnouts degradation [6÷8].

Wheel profile and diameter have to be inspected regularly, their change with time may pose threat to safety of train operation as, for instance flange angle and root radius are the variables that have a significant effect on the possibility of derailment. In any case change of the wheel profile may lead to the increased rolling contact fatigue which can have expensive and dangerous consequences [9÷10].

Therefore, monitoring wheel wear is crucial for ensuring the safe fast trains operation. Polish fast train operator InterCity decided to monitor its entire fleet of coaches and the relevant measurement system was required. GRAW developed the laser system to measure and detect automatically wheelset defects on all coaches being unique in that the profile/diameter modules take many laser images of the wheels from which all measurements are taken and statistical analysis is performed [11÷12]. The system can identify coaches from their RFID tags, based on the wheel history it can enable the pre-emptive maintenance to be conducted having the relevant defect thresholds set.

The system has been designed to perform the automatic, contactless measurement and monitoring of flange height and thickness, Qr parameter, wheel diameters on rail vehicle wheelsets, as well as for bogie geometry control. Additionally, measurement of distance inner faces is carried out. The system operation is unattended and can be remotely monitored..

## 2 System design

The system (Fig. 1) has been designed to be installed at the entrance to the depot for the automatic non-contact measurement of bogies, as well as wheel profile and diameter of coaches moving at speeds of up to 20 km/h. The system is suitable for operating at temperatures from -30 to +60°C, with humidity of up to 98%.



**Figure 1** Train entering the measurement system at Intercity Depot in Warsaw

All measurement system modules are fixed to the carrying frame, thermally insulated to minimise the effect of the changing ambient temperature. The cameras, along with the lasers are built into the housings into which the conditioned air is continuously blown in to keep them in stable conditions and to protect from dust and water.

The measurement procedure is fully autonomous and does not call for any operator involvement, as the train is detected by the ultrasonic sensor at the entry and the measurement data are stored in the local database, whose contents is automatically uploaded to the host computer at the supervisory level system. All successive axles are detected by axle sensors (Fig. 2). The particular coaches are identified using the RF/ID technique, so all measurement readings can be assigned to particular wheels for further analysis and reporting.

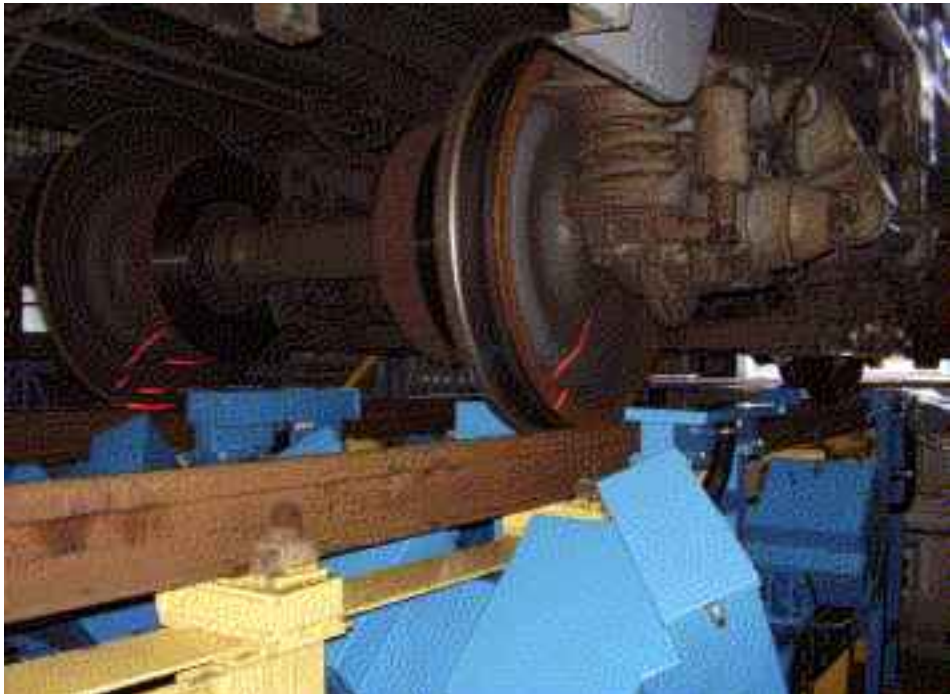

**Figure 2** Wheelset passing the measurement zone

The system consists of three main subsystems: wheel profile measurement, wheel diameter measurement, bogie geometry measurement. All measurement data is sent to the respective measurement computer and after processing the wheel data is sent to the local database. The measurement computers with the QNX real time operating system are autonomous and may operate independently from the host computer. Once the host computer is switched on all data from the local system database is automatically transferred to the main SQL database on the system operator's host computer running on MS Windows platform.

The wheel measurement database has built in reporting features making it possible to produce tabular and graphical printouts. The measurement results for coaches are stored in the databases which makes monitoring possible of the progressing degradation of the wheel profile and diameter. These reports are used for planning of repairs of coaches. For those coaches which do not have the RF/ID tags alarm signals are generated when the wheel is detected with the excessive profile wear parameter value.

### **3 Measurement principle**

The goal was to develop the system has to carry out all measurements with the contactless method. Another requirement was the unattended operation and the maintenance reduced to minimum. The laser based measurement system (Fig. 3) was developed using experience gathered in similar previous projects involving wheelset measurements [12÷15].

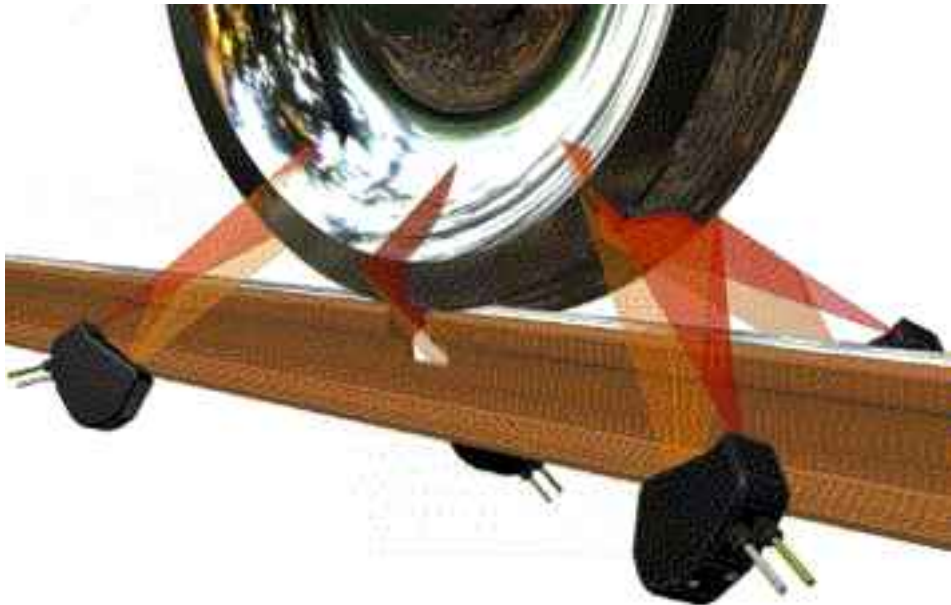

**Figure 3** Configuration of cameras and structured light sources for one wheel

The system is based on the industrial grade implementation of the light sectioning principle. The system has a modular design, so that only the selected subsystems may be installed in future installations.

### 3.1 Justification of the measurement results

As the non-contact measurement method was used, one had to make the accuracy and repeatability tests to prove correctness of the readings and also to fine tune the system. The tests were made on two coaches whose wheels were replaced on one coach, and on another one on which they were reprofiled on the underfloor lathe.

The reference contact measurements for the system were made with the A-B Profile Gauge and WM-3 Wheel Diameter Gauge made by GRAW [16÷18]. Both of these instruments were calibrated and checked on the templates before being used for the reference measurements. Therefore the wheels were measured both using the contact manual devices and later with the laser non-contact system.

Wheel profile measurements were made immediately before measurements carried out with the laser system. Profiles of all wheels were measured in two locations each that were available from the inspection pit without the need to dismount the wheel sets. The wheel diameter reference measurements were made after the measurements carried out by the laser system. The coaches were lifted which made it possible to make many diameter measurements over the entire wheel perimeter. The minimum number of measurements for one wheel was from 12 to 19.

The coaches were marshalled with the locomotive forming a test train. The measurements on the laser system were made in two series with 10 passes in each series. The train was turned before the second measurement series. This procedure made it possible to compare the readings between the independent measurement results carried out by the independent measurement module located under each rail.



### 3.2 Wheel profile measurement results

Wheel wear parameters (Sh, Sw, Qr) were compared with the measurements made with the A-B Wheel Profile Gauge. The maximum differences between the averaged values measured by the laser system and contact measurement were: for flange height 0.3 mm, flange width: 0.2 mm, and Qr: 0.2 mm, and the standard deviation values are less than 0.1 mm (Table 1). The system collects the wheel geometry information which makes it possible to monitor its continuing wear.

**Table 1** Laser system measuring range – wheel profile

Parameter	Measurement range [mm]	Standard deviation [mm]
Sh	23÷38	0.08
Sw	20÷35	0.08
Qr	6÷12	0.10

### 3.3 Wheel diameter measurement results

Wheel diameter measurements were evaluated in two ways: by the standard deviation yielding information about the system repeatability and by comparison with the measurements carried out with the WM-3 gauge, which made assessment of the calibration errors possible. The maximum standard deviation calculated independently for each measurement module did not exceed 0.2 mm. It should be noted that this is the same value as for the WM-3 gauge. Analysing this result one has to take into account that wheel measurements were taken by the system in many different locations on the wheel perimeter – just like measurements taken with the wheel diameter gauge, which means that wheel shape errors were detected also.

**Table 2** Laser system measuring range – wheel diameter

Parameter	Nominal value [mm]	Standard deviation [mm]
Diameter	840÷950	0.05
Parameter	Allowed value [mm]	Standard deviation [mm]
Difference of diameters	0.5	0.05

### 3.4 Bogie geometry measurement results

Bogie geometry measurement results could not be compared with any reference measurement, as there are no other systems that might make such measurements possible. Therefore, repeatability analysis was made, taking into account turning the trains. The parameter describing the repeatability is the difference between the maximum and minimum measured values from 20 samples. The measured bogie geometrical parameters are described in Fig. 4 and in Table 3, their deviation from the nominal values is an important premise for the relevant maintenance and repair operations.

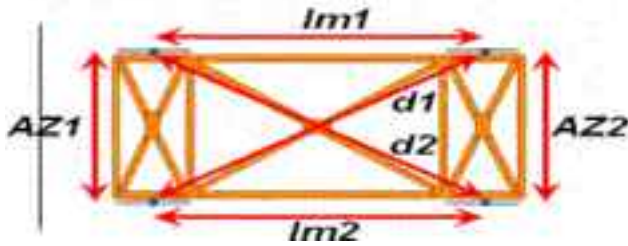

Figure 4 Exemplary bogie measurement report

Table 3 Laser system measuring range – bogie geometry

Parameter	Nominal value [mm]	Standard deviation [mm]
lm	2500÷2600	0.10
AZ	1360	0.05
d	2846÷2934	0.20

## 4 Exemplary measurement results of the system in service

The system provides the user with the current wheel and bogie geometry results which are the base for their maintenance and repair decisions. All measurement data are date and time stamped which makes it possible to analyse progress of their wear and detect changes of such trends that may require closer analysis. Such symptoms, studied automatically by the system diagnostic software to reveal the disadvantageous coincidences, give early warnings which may suggest certain corrective measures. This is especially important when such corrections may be carried out on wheels or bogies whose geometry is still within their relevant tolerances. This is an important feature extending greatly the system base functionality focused on detection of wheels and bogies whose geometrical parameters exceed the tolerances specified in the pertinent regulations. The user may specify their custom warning values which will make wheel geometry repair and even suggest that certain wear trends may indicate to geometrical errors of bogies.

### 4.1 Wheel profile measurement

The main critical criterion for deciding the immediate withdrawal of a car is detection of the excessively low Sw parameter value and/or the excessive difference of Sw parameters of the wheels in the wheel set; however, this assessment used to be done even not that long ago by visual inspection only which in many cases would not reveal the real wheel and wheel set condition. Once overlooked, the defect would lead to rapid wheel geometry deterioration which at a later time would result in huge wheel material loss during reprofiling thus cutting significantly wheel life. The average value of Sw coefficient proved to be the reliable and stable indicator of the wheel set wear (Fig.5).

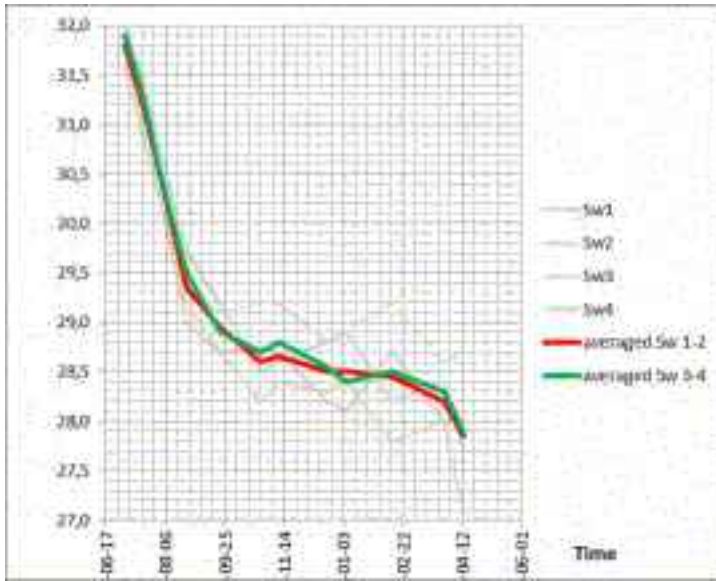

Figure 5 Sw values change between wheels (1–4) reprofiling operations for a bogie

Another important wheel geometry coefficient is Sh – related directly to wheel diameter, which is hard to measure reliably with portable instruments. Therefore, while checking the Sh values to keep them in the required tolerance range, one may also use Sh values as indication of the wheel diameter change, which may render the diameter measurement module unnecessary in certain applications. The Qr parameter easily measured with the laser system demonstrates clearly the fast initial wheel profile deterioration and maintains a steady value during the further wheel operation when no unexpected profile failures take place (Fig.6). Any disturbance of the wheel profile condition can be easily detected also from this parameter history by the measurement system diagnostic software.

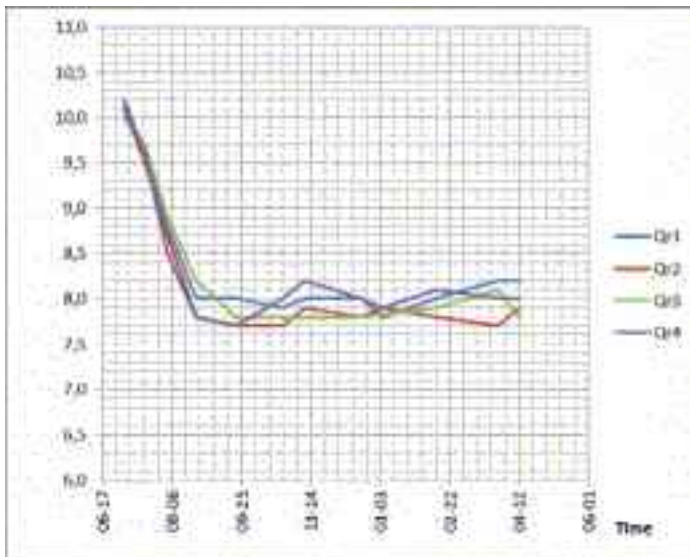

Figure 6 Qr values change between wheels (1–4) reprofiling operations for a bogie

## 4.2 Wheel diameter measurement

Automatic wheel diameter measurement results analysis makes it possible to verify quickly and reliably not only the particular wheel's diameter correctness but also checks if the difference of diameters of wheels on the wheel set, wheel diameters scatter in the bogies and in the coach (Fig.7). All this is done for all coaches in real time as the train passes the measurement stand. Wheel diameter can be measured for all brake design versions on various coaches.

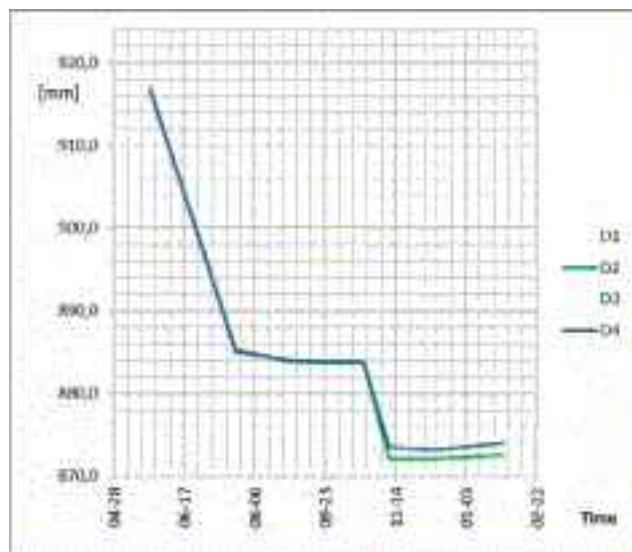

Figure 7 Diameter measurement values – it is evident how much of wheel material is lost when the wheel reprofiling is done too late

## 5 Conclusions

Apart from all consecutive the wheel measurement results for all supervised trains the measurement system database includes, among others, also the following data: removal of flat spots, build-up or oval, turning of bogie, measurement of wheel profile and diameter, measurement of build-up and flat spots, reprofiling of wheels on the under-floor lathe, and replacement of wheels and bogies.

The system database makes it possible to print wheel wear reports according to the user selected criteria, e.g., presenting wheel, bogie, and cars according to the following criteria: wheel flange height, wheel flange width, wheel diameter, differences of wheel flange widths in a bogie, differences of wheel diameters in an axle, tread surface condition, taking into account the current list of defects, list of cars with no actual measurements, car condition report, and train condition report. Effective use of the periodical measurements for their diagnostic analysis calls for their previous archiving. The advantages resulting from the periodical wheel measurements and their technically justified reprofiling on the under-floor lathe include:

- Protection from exceeding the boundary wheel dimensions.
- Possibility of the detailed wheel wear forecasting by determining the wheel tread wear growth versus its mileage, with the possibility of corrections. Periodical measurements make it possible to forecast demand for tires. This is very important with their six months or longer delivery lead time.

- Possibility of the material saving machining of wheels on the under-floor lathe by preparing the tram for this operation. Preparing the car for this operation consists in analysis of wheel dimensions before turning and in the eventual emergency replacement of single wheels worn out in a way significantly different from wear of other wheels; the replacement wheels are selected using the wheel monitoring system database. Therefore, during machining on a lathe to equalize the diameters of all car wheels, so that their difference stays within the tolerances, it is possible to reduce the required depth of cutting.
- Reprofiting of wheels up to the moment when the whole tread is used up.

## References

- [1] UIC 510-2, 'Trailing Stock: Wheels and Wheelsets. Conditions concerning the use of wheels of various diameters.' 2004.
- [2] Pombo, J., Ambrosio, J., Pereira, M., Lewis, R., Dwyer-Joyce, R.S., Ariaudo, C. & Kuka, N.: A study on wear evaluation of railway wheels based on multibody dynamics and wear computation. *Multibody System Dynamics*, 24 (3). pp. 347-366.
- [3] Jendel T.: Prediction of wheel profile wear—comparisons with field measurements, Elsevier Science B.V, *Wear* 253 (2002) pp. 89–99,
- [4] Madejski J.: 'Laser rolling stock wheel and bogie measurement system', Proceedings of the 18th International Conference on Current Problems in Rail Vehicles ProRail'2007, Žilina, Slovak Republic, 18-21.09.2007
- [5] Semih F. K.: Investigation of wheel tread irregularities, Association of American Railroads Vehicle Track Systems Newsletter, Dec, 1989
- [6] Zhai W., Cai C., Wang Q., Lu Z., Wu X.: Dynamic effects of vehicles on tracks in the case of raising train speeds, Proceedings of the I MECH E Part F Journal of Rail and Rapid Transit, Volume 215, Number 2, 12 June 2001
- [7] Jendel T., Berg M.: Prediction of wheel profile wear methodology and verification' Proc. 17th, IAVSD Symposium - Copenhagen, 2001
- [8] Esveld C.: One procedure for optimal design of wheel profile, Proc. 1st Wheel-Rail Interface management conference - Amsterdam, 2002
- [9] Tracy R.: The benefits of unattended geometry measuring, *International Railway Journal*, 2004
- [10] Madejski J., Gola A.: Tram wheel geometry monitoring system, URBAN TRANSPORT 2006 - Twelfth International Conference on Urban Transport and the Environment in the 21st Century, Prague, Czech Republic, 2006
- [11] Madejski J., Burghardt J.: Machine vision application for cold plate width measurement, Proceedings of the 12th Scientific Conference AMME-03, Gliwice- Zakopane, 2003
- [12] Grabczyk J., Madejski J., Nowicki R., Rzepka w. & Żaba P.: Automatic Wheel geometry control in trans, International Scientific Seminar - 'Railway wheelsets: Theory, Design, Manufacturing, Operation', Katowice-Ustroń, 1995 (in Polish)
- [13] Grabczyk J., Madejski J., Molerus P.: Laser Profile Measuring Gauge, 4th International Scientific Conference 'Achievements in Mechanical and Material Engineering' AMME'95, Gliwice-Wisła, 1995
- [14] Madejski J., Grabczyk J., Sitarz M.: Requirements, method, and new instruments and measurement systems for railway wheelsets, Technical Seminar - Huta 1-Maja, Gliwice, 1996 (in Polish)
- [15] Madejski J., Grabczyk J.: Track and Rolling Stock Quality Assurance Related Tools, Computer Aided Design, Manufacture and Operation in the Railway and other Advanced Mass Transit Systems - COMPRAIL 98, Special Session on 'Safety of High Speed Trains', 2-4 September 1998, Lisbon, Portugal; further extended and published as a chapter in 'Structural Integrity and Passenger Safety' - Wessex Institute of Technology, 1999.
- [16] GRAW sp. z o.o.: User Manual – P & D Diagnostic Wheel Database, Gliwice, 2009.
- [17] GRAW sp. z o.o.: User Manual - A-B Profile Gauge, Gliwice, 2009.
- [18] GRAW sp. z o.o.: User Manual - WM-3 Wheel Diameter Gauge, Gliwice, 2010



## THE ANALYSIS OF TRAFFIC ACCIDENTS ON LITHUANIAN STATE ROADS

**Stanislav Mamčič, Henrikas Sivilevičius**  
*Dept of Transport Technological Equipment,  
Vilnius Gediminas Technical University, Lithuania*

### Abstract

A great number of serious road accidents occur all over the world every year. The problem of road traffic safety is still acute in spite of some progress in this area in recent years. Road traffic accidents depend on the following factors: road traffic volume, road traffic speed, weather conditions, driving experience and driving culture of drivers. All these factors are associated with traffic safety, human lives and health. The main goal of this work is to provide the statistical analysis of traffic accidents and investigate the causes, structure, dynamics and seasonal character of traffic accidents on Lithuanian state roads with various road pavements. The data on traffic accidents, traffic volume, traffic speed, as well as the number of injured and killed people and economic losses caused by traffic accidents on Lithuanian state roads in 2004–2011, provided by the Lithuanian Road Administration under the Ministry of Transport and Communications, Lithuanian Department of Statistics, Transport and Road Research Institute and Police Department under the Ministry of Interior are analysed.

*Keywords: road, pavement, traffic accident, traffic volume,  
traffic speed, accident rate, dynamics, traffic, traffic safety*

### 1 Introduction

In many countries of the world, as well as in Lithuania, investigations of road conditions (roughness, noise, etc.) and the influence of various factors (associated with particular seasons, weather conditions, traffic intensity and the technical state) have been conducted. It has been shown that the climate and the increase of traffic can affect not only traffic safety on the road, but comfortability and communication time as well. Road traffic safety depends on many factors, one of which is road surface texture. Large quantities of moving heavy vehicles deform the pavement surface and cause rutting. The climatic winter conditions also make a significant impact on road safety. In winter time, sleet and snow on the road increase the number of traffic accidents up to 50% in the United Kingdom [1]. The analysis of the statistical data on the rate of traffic accidents in Lithuania was also performed [2]. In 2008–2009, the number of traffic accidents registered by the Highway Patrol Police of Lithuania decreased by about 1.3–1.6 times. The collisions of motor vehicles in 2009 make the largest proportion of all traffic accidents (33.4%). In 2009, drivers were the main traffic accident perpetrators (73.6%). Most of traffic accidents, which are recorded in Turkey, include the age group of drivers of 30–39 and 20–29 years, the weekdays from Friday to Sunday and road users without any or only basic education level [3]. High priority is given to the prevention of drunk-driving or driving under the influence of various psychoactive substances. Alcohol is associated with nearly the half of all traffic accident deaths in the city of San Paolo [4]. The odds for involvement in fatal road traffic accidents in Norway for different substances or a combination of

substances were in the increasing order: single drug < multiple drugs < alcohol only < alcohol + drugs. For single substance use: medicinal drug or THC < amphetamine/methamphetamine < alcohol [5]. The influence of road parameters and the surrounding area on the rate of traffic accidents was assessed [6]. Road traffic safety on the main state road network of Latvia was assessed [7]. The methods, based on the accident rate and accident frequency were used. For assessing the traffic conditions on highways [8] traffic safety rate was used, expressing the ratio between the maximum allowed speed and the eventual speed on a given section of the road. Kapski and Leonovich [9] evaluated the accident rates, using the same probability of the intersection accident prediction method. Using the potential danger method [10] made the forecasting of the traffic accidents in the conflict street areas easy. The study performed by Karlaftis and Golias [11] was aimed at determining the effects of road geometry and traffic volumes on rural roadway accident rate. By using a rigorous non-parametric statistical methodology known as hierarchical tree-based regression, the authors concluded that traffic accidents could be influenced by the average daily traffic volume, road width, road stretch servicing and maintenance parameters, as well as the type of road surface friction and pavement type. The number of traffic accidents on gravel roads can be decreased by widening the carriageway, improving the roadside infrastructure (carriageway smoothness and visibility in the overall plan), reducing the number of crossroads [12], increasing the pavement width [13], introducing the criminal responsibility for a dangerous road user's behaviour [14], as well as by using active and passive speed control measures, directing traffic away from residential areas, increasing the number of pedestrians and cyclists, providing the relevant information to the public [15] and using traffic control elements. Unfortunately, many of these measures limit traffic mobility [16]. When a vehicle is moving on an uneven road surface, periodic vehicle wheel discharges due to the vibrations occur, causing a decrease in the grip with the road surface. For this reason, it is suggested to use the accident rate and to measure the road surface roughness for evaluating traffic safety efficiency [17]. The risks of driving on a roadway with the posted speed limit of 50 miles per hour were reviewed [18]. The study allowed the authors to conclude that higher death risks and serious injuries in crashes on 50 mph-roads were associated with teen driver involvement, low restraint use rate, alcohol involvement, single-vehicle fixed object and rollover crashes as a result of speeding or driving too fast for the conditions on gravel two-lane roads. The data on traffic accidents, traffic volume and traffic speed on Lithuanian state roads for the years 2004 – 2010, provided by the Lithuanian Road Administration under the Ministry of Transport and Communications [19], Lithuanian Department of Statistics [20], Transport and road research institute [21] and the Police Department under the Ministry of the Interior [22], were collected and analysed.

## 2 Evaluating traffic accidents on the Lithuanian state roads

Lithuanian state road network consists of highways (1738.5 km), regional (4939.3 km) and local (14590.6 km) roads in total length of 21268.4 km. The dynamics of Lithuanian state roads' network in the investigated period from 2004 to 2010 remained almost unchanged, except for the local roads because the local gravel roads were paved according to the gravel road paving programme of Lithuania.

For evaluating traffic accidents on Lithuanian state roads, the parameters of the road should be considered, Fig. 1. Most of these interrelated parameters directly affect the number of traffic accidents on the road. Traffic accidents on the road depend on the following factors: road condition, road traffic, vehicle's speed, climatic and weather conditions, driving experience and behaviour of the driver, time of the day and vehicle's condition.

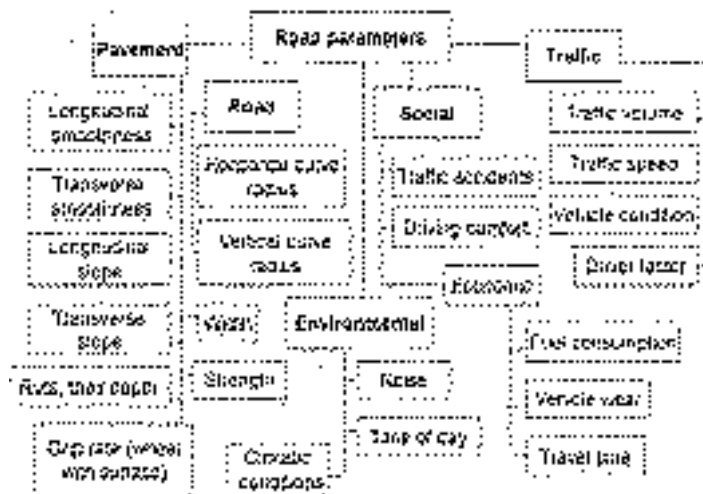

Figure 1 The parameters of the road

The evaluation of traffic accidents in absolute terms is not always correct. To compare the traffic accident rate of various regions or countries with a different traffic volume, traffic speed, the number of vehicles and the population, the relative traffic accident rates, including the number of traffic accidents per 1 million population, the number of traffic accidents per 1000 km of roads and the number of traffic accidents per 1000 vehicles, were used, Fig. 2. The number of victims (injured or killed) in traffic accidents is also taken into account.

In general, regional roads with asphalt pavement have the statistically highest traffic accident rate, Fig. 3.

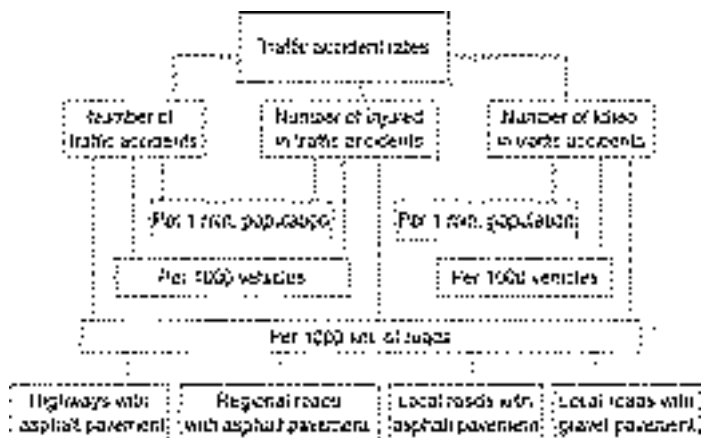

Figure 2 The parameters used in calculating the accident rate on Lithuanian state roads



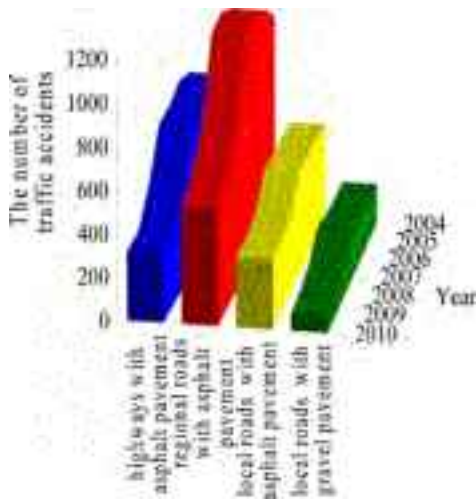

Figure 3 The dynamics of traffic accidents on Lithuanian state roads [22]

Traffic accidents on different roads with different road surface can be compared based on the traffic accident rate, Fig. 4. This universal rate evaluates the number of traffic accidents on the considered road segment, as well as the average annual daily traffic volume and road segment length. Therefore, the considered rate is more useful than the relationship between traffic accidents and traffic volume:

$$TA = \frac{A10^6}{365NLm} \quad (1)$$

where A is the number of traffic accidents on the considered road segment per year, N is the average annual daily traffic volume on the considered road segment (veh./day), L is the length of the considered road segment (km), m is the number of years.

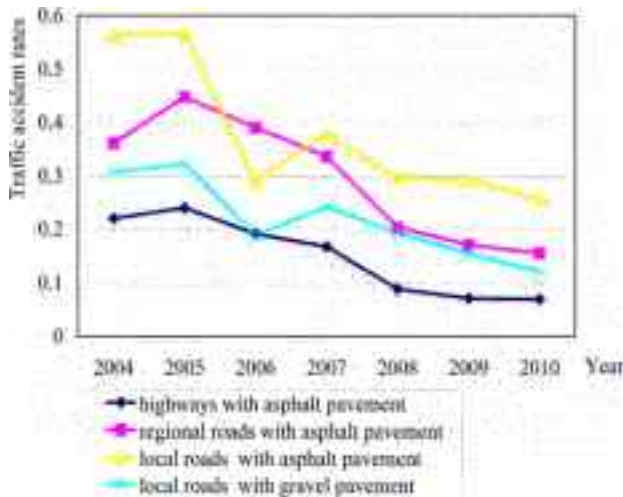

Figure 4 Traffic accident rates

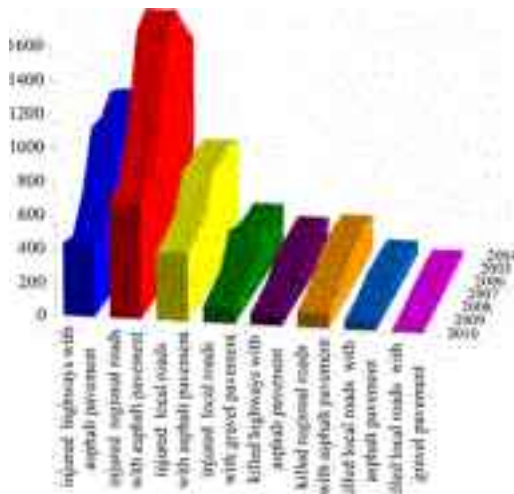

Figure 5 The number of the injured and killed in motor vehicle accidents on Lithuanian state roads [22]

The dynamics of the injured and killed in motor vehicle accidents on Lithuanian state roads is presented in Figure 5. It can be seen that the number of the injured and killed in motor vehicle accidents on Lithuanian state roads has been decreasing since 2008 and has reached the lowest values in 2010. Road traffic accidents classified according to the nature of the event are shown in Figure 6.

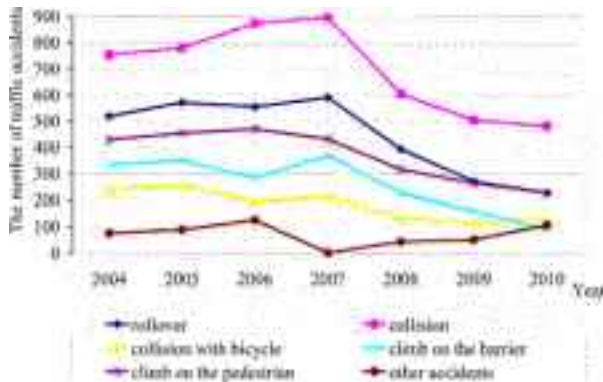

Figure 6 The types of traffic accidents on Lithuanian state roads [22]

Road traffic accidents, depending on the nature of the event, are calculated by summing up the annual values:

$$TA_{iY} = \sum_{M=1}^{12} TA_{iM} \quad (2)$$

where  $TA_{iY}$  is the number of traffic accidents of a particular type per year,  $TA_{iM}$  is the number of traffic accidents of a particular type per month.

The distribution of traffic accidents by months is calculated by summing up all types of traffic accidents for a particular month:

$$TA_M = \sum_{i=1}^7 TA_{iM} \quad (3)$$

where  $TA_M$  is the number of traffic accidents per month, Fig. 7. By summing up traffic accidents in a particular year according to their type, we obtain the total annual number of traffic accidents:

$$TA_Y = \sum_{i=1}^7 TA_{iY} \quad (4)$$

where  $TA_Y$  is the rate of traffic accidents.

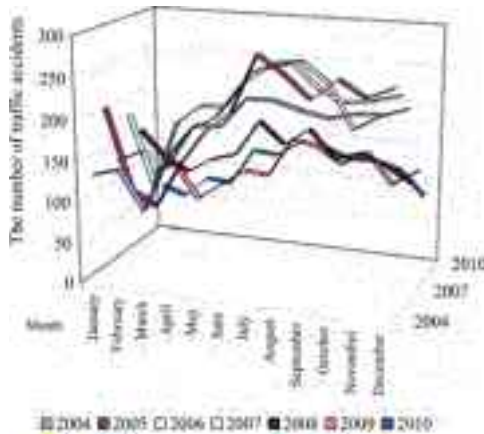

**Figure 7** Traffic accidents on Lithuanian state roads by the months of the year [22]

The analysis of traffic accidents on local roads with gravel pavement shows that the decrease of the permitted maximum speed from 90 km/h to 70 km/h in 2007 [23] has not led to the decrease of traffic accidents. However, to prove this, a more extensive study is required.

Further research is needed to assess the influence of the economic crisis that began in 2008 and is continuing now, as well as the effects of traffic volume and surface roughness on the rate of traffic accidents.

## Conclusions

- 1 Traffic accidents on the road depend on a particular season. Traffic accident rate increases from April to November because of the increased traffic volume due to better traffic conditions, with the peaks in July. It decreases in December – March because of the lower traffic intensity due to the worsening of traffic conditions and safer road user's behaviour.
- 2 The number of traffic accidents on Lithuanian roads, as well as traffic volume, decreased considerably in 2008 and 2009.

## References

- [1] Andersson, A. K. & Chapman, L.: The impact of climate change on winter road maintenance and traffic accidents in West Midlands, UK, *Accident Analysis and Prevention*, 43(1), pp. 284-289, 2011.
- [2] Prentkovskis, O., Sokolovskij, E. & Bartulis, V.: Investigating traffic accidents: a collision of two motor vehicles, *Transport*, 25(2), pp. 105-115, 2010.
- [3] Sari, M., Mutlu, O. & Zeytinoglu, A.: Effects of human and external factors on traffic accidents, *Petroleum – Gas University Bulletin, Mathematics – Informatics – Physics Series*, 61(1), pp. 9-18, 2009.

- [4] Ponce, J. deC., Munoz, D. R., Andreuccetti, G., Goncalves de Carvalho, D. & Leyton, V.: Alcohol-related traffic accidents with fatal outcomes in the city of Sao Paulo, *Accident Analysis and Prevention*, 43(3), pp. 782-787, 2011.
- [5] Gjerde, H., Normann, P. T., Christophersen, A. S., Samuelsen, S. O. & Morland, J.: Alcohol, psychoactive drugs and fatal road traffic accidents in Norway: a case – control study, *Accident Analysis and Prevention*, 43(3), pp. 1197-1203, 2011.
- [6] Šliupas, T.: The impact of road parameters and the surrounding area on traffic accidents, *Transport*, 24(1), pp. 42-47, 2009.
- [7] Lazda, Z & Smirnovs, J.: Evaluation of road traffic safety level in the state main road network of Latvia, *The Baltic Journal of Road and Bridge Engineering*, 4(4), pp. 156-160, 2009.
- [8] Akhmetshin, I. A., Afliatonov, A. A. & Dautov, F. M.: The use of safety factor for assessing traffic conditions on motor roads, *ИЦБЖД*, 2(2) bulletin, pp. 219-225, 2009.
- [9] Kapski, D. & Leonovich, I.: Improvement of road traffic safety on the basis of forecasting a potential danger in places of conflict situations, *The Baltic Journal of Road and Bridge Engineering*, 1(2), pp. 83-92, 2006.
- [10] Kapski, D., Leonovich, I. & Ratkevičiūtė, K.: Theoretical principles of forecasting accident rate in the conflict sections of the cities by the method of potential danger, *The Baltic Journal of Road and Bridge Engineering*, 2(3), pp. 133-140, 2007.
- [11] Karlaftis, M. & Golias, I.: Effects of road geometry and traffic volumes on rural roadway accident rates, *Accident Analysis and Prevention*, 34, pp. 357-365, 2002.
- [12] Zegeer, C. V., Stewart, R. & Neuman, T. R.: Accident relationships of roadway width on low-volume roads, *Transportation Research Record*, 1445, pp. 1-10, 1994.
- [13] Sulistio, H.: Effect of traffic flow and shoulder width on motorcycle accidents at non-signalized intersections, *Journal of Mathematics and Technology*, 5, pp. 35-42, 2010.
- [14] Novoa, A. M., Perez, K., Santamarina-Rubio, E. & Borrell, C.: Effect on road traffic injuries of criminalizing road traffic offences: a time-series study, *Bulletin of the World Health Organization*, 89(6), pp. 422-431, 2011.
- [15] Short, J. R. & Pinet-Peralta, L. M.: No accident: traffic and pedestrians in the modern city, *Mobilities*, 5(1), pp. 41-59, 2010.
- [16] Kinderytė-Poškienė, J. & Sokolovskij, E.: Traffic control elements influence on accidents, mobility and the environment, *Transport*, 23(1), pp. 55-58, 2008.
- [17] Filippov, V. V., Smirnova, N. V. & Kiyashko, D. I.: Evaluating the influence of road pavement on traffic safety, *The bulletin of the Kharkov National Automobile and Highway*, 47, pp. 63-65, 2009.
- [18] Dhungana, P. & Qu, M.: The risk of driving on roadways with 50 miles per hour posted speed limit, *Journal of Safety Research*, 36(5), pp. 501-504, 2005.
- [19] Lithuanian road administration under the ministry of transport and communications, [www.lra.lt](http://www.lra.lt), 14.02.2012.
- [20] Lithuanian Department of Statistics, [www.stat.gov.lt/lt/](http://www.stat.gov.lt/lt/), 14.02.2012.
- [21] Transport and road research institute, [www.tkti.lt](http://www.tkti.lt), 14.02.2012.
- [22] Police department under the ministry of the interior, [www.policija.lt](http://www.policija.lt), 14.02.2012.
- [23] Government of the republic of Lithuania 5 October 2006 resolution no. 975 'For the rules of the road' change.





## ANALYSIS OF ROAD TRAFFIC SAFETY AFTER THE CONSTRUCTION OF THE FULL PROFILE OF THE RIJEKA–ZAGREB MOTORWAY

Željko Denona, Boris Huzjan, Tatjana Matković  
*Rijeka–Zagreb Motorway, Croatia*

### Abstract

Upgrade of the Rijeka–Zagreb motorway to full profile was completed in October 2008, and its basic aim is raising the level of traffic and safety-related services primarily through reducing the number of road traffic accidents. This paper presents the current situation, possible causes of road traffic accidents with a special commentary of the main factors of traffic safety. A detailed analysis of the accidents was carried out, and the methods, procedures and solutions with the objective of increasing traffic safety were suggested in the stated methodology.

*Keywords: safety, road traffic accident, causes and analysis, methods, solutions*

### 1 Introduction

The Rijeka–Zagreb motorway is a part of the European road route E65 Budapest–Varaždin–Zagreb–Rijeka, which links the Central European countries with the port of Rijeka, and further towards the other Mediterranean and Middle East countries. In addition to its role in the European context, this road represents a key link of the continental and coastal part of the Republic of Croatia, and integrates the area of the country connecting it with the European transport corridors.



Figure 1 Rijeka–Zagreb motorway

Rijeka–Zagreb motorway (Figure 1.), 146.50 km long, was open to traffic in the second half of 2008 as a dual carriageway. The completion of a safe, reliable and fast traffic link of Croatia's capital with the largest port was a key factor of the Traffic Development Strategy of the Republic of Croatia.

## 2 Traffic safety conditions

By its character, a motorway is an infrastructure road object with 'a high level of servitude', and it gives users the highest standard in comfort and safety. The objective of the global campaign 'MAKE ROADS SAFE' which was conducted through 2007 was raising awareness of road users and general public on road safety worldwide, as a priority issue within sustainable development. The Rijeka–Zagreb motorway is in every respect constructed according to the highest standards, however, even though modern roads are a lot safer compared to other roads, the experience of the countries in which motorways have been used for years, shows that road accidents on modern roads occur with tragic consequences.

### 2.1 Official data and classification of road accidents

In order to gain a clearer insight into the number and consequences of road accidents, accidents are shown by means of various safety coefficients per 100 million of driven kilometres. The term 'driven kilometres' represents a product of the number of vehicles on a particular section together with length of that particular section. By stating the safety level through these coefficients, it is possible to compare the condition of traffic safety under various loading on roads of diverse length and construction stage (single/dual carriageway) (Figure 2.). Comparison of traffic volume on the single/dual carriageway in 2008/2011 is shown in Table 1.

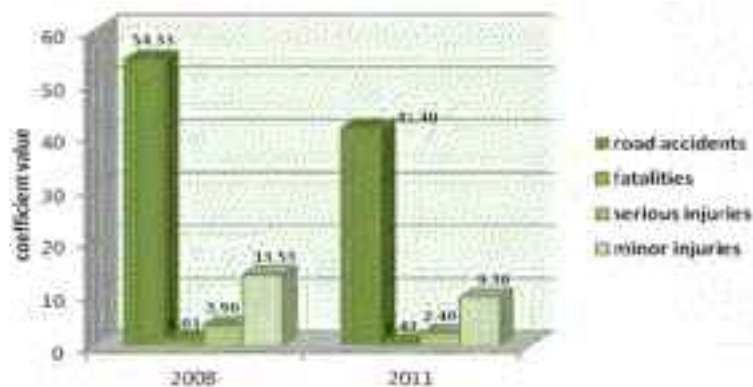

Figure 2 Comparison of coefficients per 100,000,000 driven kilometres in 2008 and 2011 on Rijeka–Zagreb single/dual carriageway according to consequences [4]

**Table 1** Traffic volume on single/dual carriageway in 2008 and 2011 [4]

Year	2008	2011	
Traffic volume	14,863,300	14,591,938	
Driven kilometres	975,421,678	968,675,212	
Total accidents	530	401	
Fatalities	10	4	
Serious injuries	38	23	
Minor injuries	132	90	
on			
100 000 000	Total accidents	54.33	41.40
driven km	Fatalities	1.03	0.40
	Serious injuries	3.90	2.40
	Minor injuries	13.53	9.30

### 3 Causes and analysis of road accidents

In road traffic structure we can see a mechanical system, which consists of the 'vehicle–road' relation and the biomechanical system, which consists of the 'person–vehicle' and 'person–road' relations [1]. The effect of these three systems to traffic safety can be shown by the Venn diagram (Figure 3.) [2].



**Figure 3** Venn diagram

If the cybernetic system consisting of the following factors: 'driver', 'vehicle' and 'surroundings' is considered, then the function of operation is carried out by the driver, vehicle is the object of the operation, while the surroundings refer to a source of information based on which the condition of the system is defined. In the factor called 'surroundings', the road is singled out as a carrier of information.

The factors: 'person', 'vehicle' and 'road' do not cover all the elements that can have an effect on the condition of the system, such as e.g. traffic regulations, traffic operation etc.; 'traffic on the road' should be singled out as the fourth factor. Those factors are subject to certain regularities, but they do not include other elements which occur unexpectedly or unsystematically, and they have an effect on the situation of the system. This mainly refers to the weather conditions and other elements, such as stones on the road, oil and mud on the road surface. Therefore a need to introduce another factor appears in which all the mentioned elements are contained. That factor is called 'incident factor' in order to single out its unsystematic and unexpected occurrence.



### 3.1 Road as a factor

Technical road deficiencies are often a cause of road accidents, and they can occur during road design and construction (Table 2.). Road as a factor of road safety is characterized by: alignment, technical road elements, pavement condition, road furniture, road lighting, intersections, side barrier influence and road maintenance [3]. Particularly important is the characteristic of the road alignment which should be homogeneous, i.e. that it enables uniform speed of vehicles.

**Table 2** Overview of road accidents according to road characteristics for the period from January–December 2008 and 2011 [4]

Road accidents according to road characteristics	No. of accidents	F	SI	MI	MD
	Jan–Dec 2011				
Curve	112	2	16	32	85
	94	1	8	22	76
Straight road	313	5	20	84	247
	236	2	12	60	193
Tunnel	14	-	-	4	11
	13	1	3	4	8
Viaduct/Bridge	19	3	2	5	14
	-	-	-	-	-
Interchange	30	-	-	5	27
	22	-	-	1	21
Toll plaza	25	-	-	1	24
	23	-	-	-	23
Other	17	-	-	1	16
	13	-	-	3	11
Total	530	10	38	132	424
	401	4	23	90	332

### 3.2 Vehicle and driver in traffic

Vehicle elements which have an effect on traffic safety can be divided into active and passive elements [5]. Active elements include those technical solutions of vehicles that have a duty to minimise the number of road accidents e.g. brakes, tyres, lighting and signalling devices, i.e. to reduce the possibility of road accident occurrence. Passive elements include those technical solutions that have a duty to alleviate the consequences of road accidents (e.g. safety belts, headrests, air bags).

The most important of all factors which influence the safety in traffic is the driver/person. When in traffic, the driver receives information on the conditions on the road, takes into account the vehicle and traffic regulations, and then determines the vehicle's course [6]. The 'person' factor is the most important one, but at the same time the weakest link in the safety chain. According to the analysis, a large number of road accidents occur due to unadjusted speed and not maintaining a safe following distance in conditions of clear visibility and good pavement conditions (Table 3.). Improper speed and speed unadjusted to road conditions are the most frequent drivers' mistakes which lead to road accidents.

**Table 3** Overview of the number of road accidents according to road users' mistakes for the period from January–December 2008 and 2011 [4]

Road accidents According to road users' mistakes	Jan – Dec 2008	Jan – Dec 2011
Speed unsuitable for road conditions	159	140
Unexpected danger on road	56	27
Improper backing	10	10
Improper changing of lanes	30	28
Improper passing	13	2
Improper turning	12	3
Joining traffic improperly	14	3
Driving at inadequate distance	91	56
Other driver's mistakes	145	132
Total	530	401

### 3.3 Weather conditions and influence of other factors

Weather condition factors that most frequently influence road traffic safety are: rain, snow, glaze ice, fog and wind (Table 4.). It is also necessary to mention the wind as an explicit cause or circumstance of road accident occurrence. Due to wind, speed limits should be implemented on those specific areas where it occurs. There are in general fewer accidents in conditions with snow on the pavement, since there are fewer vehicles on the road, and those who are driving are more careful and drive slowly. Hence there are more road accidents with minor material damage than accidents with injuries. Typical winter road accidents are vehicle impacts, which occur due to the speed unadjusted to road conditions. It is indisputable that correct and timely meteorological information is very useful and essential for road users in the sense of increasing the level of safety in traffic. Such information on Rijeka–Zagreb motorway can be found on the Company's web page [www.arz.hr](http://www.arz.hr) (Autocesta Rijeka–Zagreb d.d.).

**Table 4** Condition of road surface on occurrence of road accidents for the period from January–December 2008 and 2011 [4]

Condition of road surface on occurrence of road accidents	No. of accidents	F	SI	MI	MD
	Jan–Dec 2008				
	Jan–Dec 2011				
Dry	380	7	29	108	301
	296	4	20	70	245
Wet	139	3	5	23	114
	88	-	3	16	74
Snow–ploughed	7	-	2	1	6
	10	-	-	3	7
Snow–unploughed	2	-	-	-	2
	6	-	-	1	5
Ice	1	-	2	-	-
	1	-	-	-	1
Oil and other	1	-	-	-	1
	-	-	-	-	-
Total	530	10	38	132	424
	401	4	23	90	332

Presence of animal species along the motorway route is one of the more important factors, which need to be mentioned, and which has an effect on the road traffic safety (Figure 4.).



**Figure 4** Notification for the drivers on game habitat

Taking into consideration the ground configuration, there are many tunnels, viaducts and other passages as well as one animal crossing – Dedin, which is 100 m long and enables natural migration of animal species, on the extensive portion of the motorway. In its entire length the motorway is enclosed by safety fence and its primary objective is to prevent the animals from entering the motorway and increase the safety of road users, as well as animals which live in their natural habitat. Animal hits participate with 4% in the total number of road accidents. Most road accidents occur on the section of the motorway between Zagreb and Bosiljevo, since ground configuration in that area is lowland, and there are fewer possibilities for animal migrations when compared to the section between the Bosiljevo and Orehovica Interchange (mountainous area) with the entire range of road structures which serve as animal crossings. In most of the cases animal hits occurred in the evening, with mainly material damage.

## **4 Methodology of finding measures to increase road safety**

The main focus areas in increasing motorway safety refer to users, vehicles, road infrastructure, safe transportation of goods and passengers (heavy vehicles and buses), emergency services and care for accident victims, and collection and analysis of accident data. In Rijeka–Zagreb Motorway, data collection is done in the following way: when an accident occurs, a form is filled out to collect detailed data such as speed at the moment of the accident, use of safety equipment, detailed condition of the road surface in summer and winter conditions, signalling, etc.

### **4.1 Methods and pragmatic steps**

Experience and scientific and research work in the world, and to some extent in the Republic of Croatia, confirms that effective decrease of road accidents and their consequences is made possible by influencing the change in the drivers' surroundings at dangerous points, i.e. the surroundings of road users, in order to communicate set up clear and unambiguous information on road layout that drivers get from their surroundings, and which are important for safe vehicle operation. The surroundings of road users, primarily drivers, include the complete image drivers see and its relationship to road layout and the drivers' actions to take appropriate measures to avoid a road accident. Suggestions to improve dangerous points (so-called black spots) can be made in the form of typical (usual) solutions, atypical (unusual) solutions and a combination of the two. Typical solutions add up to changes to the drivers' surroundings through signalling:

- putting up traffic signs (restrictions, mandatory signs and limits),
- putting up panels for traffic direction (visual barriers – red and white or in different colours) of appropriate dimensions (standard and non-standard – large),
- removing certain visual obstacles or barriers (commercial billboards) which distract the driver or block clear vision, and similar.

Atypical solutions include changes to the surroundings by placing certain elements in the field of vision of the driver, such as hedges (shrubs and trees), visual walls (panels of different sizes, colours and shapes), and changes to the colour of certain roadside elements. The combination of typical and atypical solutions includes systematic use of both solutions to achieve the best system of information on road layout as possible. Progressive increase in dimensions of certain elements is also possible, and serves to highlight certain elements of the road by way of visual illusion (sharp bends, and similar elements), so that the drivers can instinctively react by reducing their speed on time.

#### 4.2 Modelling and implementing the measures

By constructing roads of a higher level of service, i.e. roads with superior elements, or with larger radii of horizontal and vertical bends, smaller longitudinal slopes, multi-level intersections, built parking lots, signalling and computer systems to direct and manage traffic, better road maintenance – the level of service is greatly improved and the safety is greatly increased. Improving dangerous points by changing the drivers' surroundings can decrease the number of road accidents in dangerous points by between 30 and 70% or more, if it is done on the basis of scientific and professional understanding and approach. Measures to improve dangerous points refer to changing the drivers' surroundings, i.e. introducing standard and non-standard traffic signalling, and to a lesser extent to equipment on the part of the road at the dangerous point. Micro asphalt surfacing or roughening of the road surface is sometimes understood as a complementary measure required as a result of a study or research efforts.

### 5 Conclusion

By analysing all factors causing a road accident, it is possible to design and optimise solutions for decreasing the number of road accidents, and the number of 'black spots' on certain parts of the motorway. Along with decreasing the number of fatalities in 2011, the number of serious injuries has decreased by 15, and the number of minor injuries by 42, compared to 2008. Companies operating motorways in the Republic of Croatia, including Rijeka–Zagreb Motorway, aim at providing quality service to their users, and enable them to use the motorway for a safe and fast journey. Regular maintenance, which is done within the available financial framework, serves as a way to raise the level of service of the road, and make the journey safer and more comfortable.

### References

- [1] F. Rotim: Elements of road traffic safety; Expert's report on road accidents, 2nd ed., Scientific Council for Traffic, Yugoslav Academy of Science and Art, Zagreb, 1989
- [2] J. Golubić: Techniques and the basics of traffic safety, Faculty of Transport and Traffic Sciences, Zagreb, 1997
- [3] J. Božičević, D. Topolnik: Infrastructure of road traffic I and II, Faculty of Transport and Traffic Sciences, Zagreb, 1996
- [4] Rijeka – Zagreb Motorway; Motorway Maintenance Subsidiary: Internal documents, Zagreb, 2008 and 2011
- [5] <http://www.sup.hr>
- [6] <http://www.hsrb.unc.edu>





## INTEGRATING HUMAN FACTOR IN THE ANALYSIS OF THE INTERACTION 'TRAM – CAR DRIVERS'

Fatiha Moutchou<sup>1</sup>, Abdelghani Cherkaoui<sup>1</sup>, El Miloudi El Koursi<sup>2</sup>

*1 Mohammadia School of Engineering, Morocco*

*2 The French institute of science and technology for transport,  
development and networks, France*

### Abstract

Trams are effective alternatives to private car as means of travel in Moroccan towns and cities, and on this basis they are being promoted by the government. However, issues relating to their impact on road safety are one of the main societal concerns today. Indeed, trams share the same road network with all road users. Ensuring that the network works efficiently for all modes and users – cyclists and pedestrians as well as car drivers – presents a significant, but essential, challenge for those who plan, design and fund the transport system. In the light of this, many research studies have shown that poor road design may enhance the driver's tendency to error and misjudgement and lead to unwanted situations (accident, pre-accident, congestion, etc.).

Moving the focus of research away from the driver in isolation and focusing more on the interaction of the drivers and the changing environment, through which they move in time and space, can be regarded as hard core among road safety problems to investigate. This supposes assessing human abilities and limitations and ensuring that the resulting systems that involve human interaction are designed to be consistent with these human limitations and will be a full proof system.

The general aim of this article is to further knowledge about the influence of tramway and the surrounding environment on car's driver behaviour. Understanding these influences, involves conducting a systematic review of the cognitive tasks related to driving and identifying the hazards that can arise at each task, and what factors can make these more or less likely to arise, considering the environmental design and behavioural factors. To achieve that, the Hazop approach is conducted for this study. Concerning data collection, our methodology includes site visits to record user behaviour and questionnaires to determine the opinion, concerns and knowledge of car drivers in interaction with the tram environment.

*Keywords: tram, urban development, human factors, road safety, cognition*

### 1 Introduction

In response to growing problems of road safety related to travel, the road transport network in Morocco has been modernized with the implementation of Rabat–Sale tramway since April 2011. After Rabat, the city of Casablanca also launched the realization of this tram project, whose railway length is almost 30 km. Even though the achievements are few, the projects with significant investments are there and therefore it is logical that Morocco is particularly concerned with the road security strengthening.

At the moment, road users in Morocco are also not qualified enough to adapt to the current situation of modern and advanced developments in the road traffic system. In fact, a study

[1] conducted in urban areas of Morocco has shown that, in comparison with the multitude of dysfunctions observed the accidents are few. It has been noticed in this report, that 'The road traffic is distinguished by the local customs of behaviour acquired over time with the evolution of the complexity of traffic'. This finding justifies that research should be conducted to further knowledge about the influence of tramway and surrounding environment, (specifically at crossroads) on car' drivers behaviour, and it is the general aim of this article. Understanding these influences, involves conducting a systematic review of the cognitive tasks related to driving and identifying the hazards that can arise at each task, considering the environmental design and behavioural factors.

The first part of the article seeks to investigate the interaction between trams and cars within the road network; we also discuss problems that drivers have to face with at crossroads. Then from a literature review of driver behaviour psychological models, we propose our framework to study the interaction of Tram-car driver. In the third part we will present our hypothesis and research approach. The conclusion insists on the interest of our approach to understand the drivers' behaviour and the interface between tram environment and car driver. [Second Level Heading] Second level heading

## **2 Car-Tram interactions within the road network**

### **2.1 Some broad issues**

Cars and trams are at opposite in terms of size, mass and manoeuvrability but they share the same road network. Both Trams and cars may have parts of a roadway set aside for their specific use. However, neither of these is necessarily exclusive (especially at crossroad) and conflict can result. The interaction between cars and trams on the road system will have three major types of consequence on:

- Infrastructure capacity requirements: in terms of damages to the infrastructure and rolling stock that can occur during an accident and which may be heavy in terms of economic damages and number of victims. Indeed as a mode of public transport, the accidents involving tram with other road users may involve a large number of victims. However, as of now there is comparatively little information about the background of the involvement of trams in crashes in Moroccan urban areas, but the media side on accidents involving public transport (in this case a tram) should be noted. Even though they are few, they are totally unacceptable to the public opinion;
- Operational performance, in terms of safety and travel time: conflicts between cars and tramway can have negative impacts on both trams and cars in different ways, causing tram delays and inconvenience;
- Perceptions, particularly by the car driver, which lead to changes in travel behaviour.

### **2.2 The urban effects of the tramway: principles of urban development**

In all countries, the fight against pollution and congestion has been tackled in urban areas through the promotion of tramway as they have been considered the optimal option for fostering public transport patronage and also for getting a sustainable mobility for the growing urban population [2]. Tramways provide fast, regular, safe and comfortable services. At the same time, they provide a modern image to the city.

In spite of the growth in the interest of this urban rail system, it is well known that the tramway line implementation leads to changes, both in terms of the urban shape as on the overall functioning of the city. Indeed the place occupied by the tram on the roadway is directly taken from the car. More specifically, most tram-car interaction within the road network takes place in the context of the existing road infrastructure, which has physical limitations and implicit, sometimes explicit, limitations on additional capacity provision. But beyond the

physical dimension of this competition for space, there is also a misunderstanding of the rules relating to this mode as of its constraints of traffic. The rule 'tram has priority over all users' is explained by the fact that the tram is a vehicle on rails, it cannot avoid an obstacle but it is also explained by the big braking distance necessary to a tram to stop. More generally, tram priority is assuring the tram movement through an area without the potential detriment of others users of this area. These will often be where traffic volumes are high, traffic speeds are low and vehicles movements are complex (e.g. crossroads).

### **2.3 Crossroads Problem: understanding human behaviour**

Crossroads navigation is a particularly hazardous component of driving. Even though crossroads comprise just a small amount of the roadway surface area, they are generally more complex and difficult to navigate than most other road segments. More specifically, crossroads can be visually complex, requiring that drivers scan several different areas and keep track of tram and several different elements to get the information they need to safely pass [3]. Specific issues of visibility and manoeuvrability are likely to occur at crossroads. So great attention is paid nowadays to the meaning of the space the driver is moving in. This area of research and action is known as the 'Road readability'.

'Road legibility', 'Road Readability' and 'Self-Explaining Roads' all raise the question of how the road infrastructure could support drivers' activity. The concept of the 'Self-Explaining Road' is defined in terms of the processes by which drivers' expectations are structured. 'SER are roads with a design that evokes correct expectations from road users (...). This means that drivers are given direct information about the type of road they are driving along and the type of behaviour required' [4]. Therefore, for a safe situation it is important that every road user can see all the other road users and that everyone knows what is expected of him.

Road design and traffic management primarily deal with the realities of the road system and of road use. In practice, however, the actual safety and convenience of road use depend heavily on drivers perceptions of both the road and traffic conditions and of other users.

In Morocco, traditional methodologies mostly focus on single effects of causing parameters to traffic unsafe situations. For example, in most of the statistical reports on traffic safety in Morocco [1], it is written 'speeding behaviour has the highest percentage in all causes of traffic conflicts and /or accidents'. However to explain the accident, one should not seek to attach blame to a single and last element, but to see how the interaction system broke down. Many researches have considered that the problem is not unsafe drivers or unsafe road users, but the unsafe complex system. Drivers, pedestrians, and other road users will continue to make errors as long as the road system exists. It was concluded [5] that rather than focusing entirely upon removing road user error, effective error management in road transport should focus on increasing the capacity of the road transport system to tolerate error. This fact has guided our research in this area to an approach that takes into account the Moroccan road context and behaviour of the driver in this context.

## **3 State of knowledge on human behaviour in driving**

### **3.1 Human functional failure**

The specific role of human factors inside the traffic system has to be stressed in order to go further than the usual view on accident factors. It is important to be aware of the very specific role of the human element: it is both a component and the principal actor [6].

When a driver fails to avoid an accident because the situation exceeds their limitations, it is often called 'human error.' Safe and efficient driving requires the adequate functioning of a range of abilities including vision, perception, cognitive functioning and physical abilities,



and loss of efficiency in any of these functions can reduce performance and increase risk on the road [7].

It is consequently the same process which allows the drivers to adapt to the difficulties of the environment and which sometimes may fail and lead them to error. As the cost of human error can be very high, it is important to find out why human error happened and how it can be prevented in the future [8]. For this purpose, the cognitive approach is especially suitable for analysing higher order functions such as problem solving, and decision making.

### 3.2 Human behaviour models

There is a great amount of literature dealing with analysis models, giving preference in one way or another to the description of functional sequences such as: information acquisition, processing, decision, action. This type of model is aimed at understanding the malfunctions. Other model types are built up using the description of driving task [9].

Two theoretical models that originate from cognitive psychology and are frequently mentioned in the literature on road user behaviour are Endsley's model of information processing, and the hierarchical structure of the driving task as described by Michon. The reason for mentioning these models and not others, is that the models listed are all considered to be relevant for describing traffic behaviour [10],[11],[12],[13], and, more importantly, because they are complementary.

Endsley's model of information processing [14], serves as a starting point. Endsley proposes a model of human decision-making related to situation awareness (S.A). The concept of situation awareness focuses on the mental picture of the situation that people find themselves in and how this picture can be distorted or improved by internal and external factors. Endsley's model illustrates three stages or steps of SA: (i) perception, (ii) comprehension, and (iii) projection. The first level of SA, involves the processes of perception, cue detection, and simple recognition, which lead to an awareness of multiple situational elements (objects, events, people, systems, environmental factors) and their current states (locations, conditions, modes, actions). At the second level of SA people combine, interpret, store and retain the collected information. The third and the highest level of SA (called projection) involves the ability to project the future actions of the elements in the environment. These characteristics make it a suitable model for studying the formal stages involved in unsafe or undesirable situations. We also borrowed from Michon [15] the distinction he makes in the driving task between the strategic, tactical and operational level. On the strategic level, driver makes decisions related to planning and executing a trip from origin to destination. The task on the tactical level requires taking decisions about driving speed and how to handle specific traffic situations such as crossing a crossroad. In this situational context he plans maneuvers that suit the navigational objectives. Finally, at the operational level, the driver takes decisions that relate to vehicle control [16].

It's obvious that other aspects of driver behaviour, such as experience, intentions, attitudes, emotions and spatial properties including location, size, separation, connection, shape, landmarks, and movement also play an important role in modeling driver behaviour. Consequently, it is vital to be aware of how spatial knowledge and beliefs are acquired and developed over time; and how aspects of spatial knowledge and reasoning are similar or different among individuals or groups. This approach gained insight from the work of Kevin Lynch (1960), a planner who argued that 'images' of cities guide people's behaviour and experiences of those cities [17], [18], [19]. In fact, there is a growing need to include spatial cognition explicitly in models [20].

With this in mind, the articulation of models presented before seemed to us particularly interesting to fully understand human behaviour in typical driving situations. We also combine notions of cognitive mapping to our own analysis to suggest how cognitive mapping might be employed to help us better understand and predict driver behaviour. We therefore set out

to develop a driver behaviour framework to generate and test hypotheses about the specific causes of (un)safe driving behaviour in crossing crossroads that pass through a tramway line. Figure 1 below, shows the diagram for assessment of the tram – car driver interaction; it indicates variables moderating the hypothesized relationship to be tested in our field study.

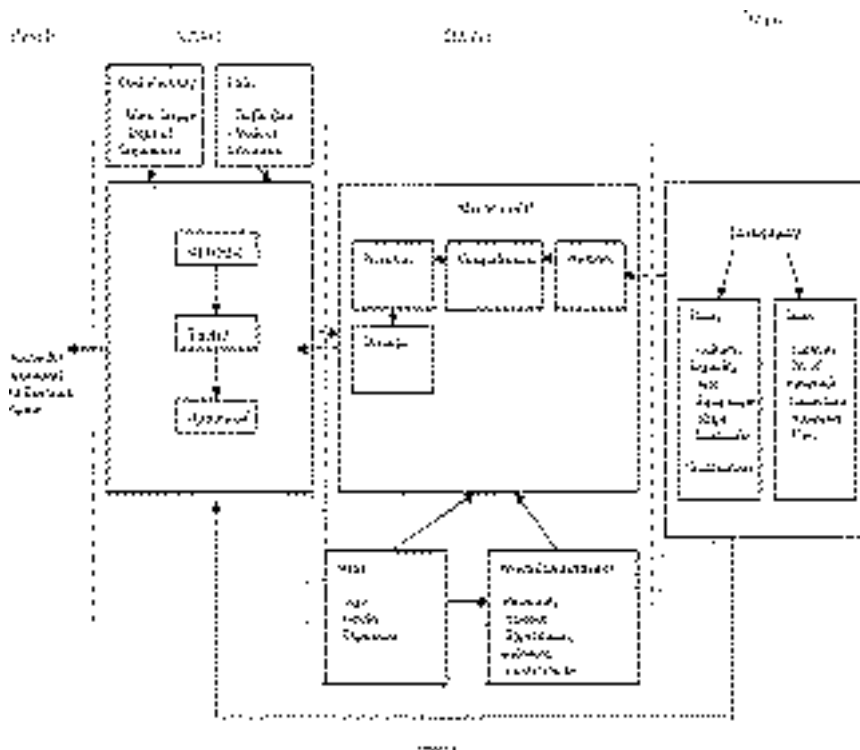

Figure 1 Diagram for the tram-car driver interaction assessment

## 4 Hypothesis and research method

### 4.1 Research hypothesis

Several research works [21], [22], [23] have helped to affirm that road design elements play a role in the difficulties that drivers encounter in traffic. These different studies have led us to formulate our general hypothesis of research, which can be defined as follows.

Driver behaviour at tram crossroads will depend very much on what is seen or 'not seen', by the driver, in the road scene and how he 'reads' the situation. Briefly speaking, our analysis aims to answer three questions: (i) how (how often) do people behave at specific crossroads crossed by a tramway line? (ii) why do they behave that way? (iii) what are the results of such different behaviours?

## 4.2 Research methodology

To meet our research hypotheses, our methodological proposal is largely based on the functional and dysfunctional approaches which are consistent with our goals. Among them are such techniques as Hazard and Operability Study (HAZOP). In our study, failure constitutes the limits of cognitive functions engaged by the driver in a context of driving activity at crossroad. For each failure that refers to a function of the driver's mental model in degraded mode, a quantitative and qualitative assessment will be conducted to identify potential accidents that can result from the deviations, to determine the cause of the deviation and to find the safeguard which helps to reduce frequency of problems encountered by drivers in crossing tram crossroad.

HAZOP is a classic tool of the industrial world, our work was to adapt it to the context of the study by simplifying it to facilitate its ownership by stakeholders. At this level, our work joins several HAZOP studies in the road sector including one conducted by a research program initiated by 'Rail safety standards and Board' and whose results were published in the report 'Understanding Human Factors and Developing risk reduction solutions for pedestrian crossing at railway stations' [24].

To validate our hypotheses and our methodological proposal, a particular attention is paid to data collection. Observational surveys will be used to record user behaviour and a questionnaire to determine the opinions, concerns and knowledge of users. The observation is based on an analysis grid to carry out the assessment, and to examine whether it would be possible to identify characteristics of crossroads that coincide with a higher likelihood of unwanted events. To guide our choice of elements to be included in this grid, we were inspired by the work of Millot [21], taking care to adapt the reading points to our own field of study and to our specific questions. To complement those observations, a face to face interview using the existing situational questions, will be conducted to encourage drivers to express their opinion and share their potential accident experience information which will contribute significantly to gathering information for hazard identification and prevention of traffic accidents and congestion.

## 5 Conclusion

There is very little literature concerning the interaction between the tram environment and the drivers' behaviour. To address this issue we are therefore oriented towards the methods used in urban development, and human cognition.

While moving, the driver evolves – particularly in crossroads – in a complex and extremely dynamic environment, hence the need to set up developments which allow the driver to discern, to identify and to choose easily in this environment, the indices for the effective regulation of its activity.

The methodology we have presented here represent an analytical approach. The interest of this approach is that it attempts to obtain an overview of drivers' behaviours in specific driving situation (e.g. crossroad crossed by tramway line) and the variables likely to explain them using complementary indicators: site visits to record user behaviour and questionnaires to make drivers precisely explain their perceptions of the facts, their decisions, actions and the difficulties they encountered. The findings from this study will provide suggestions for minimising potential conflict between cars and trams and for enhancing error tolerance at crossroads that pass through tramway lines and within the Moroccan road transport system in general.

## References

- [1] Boulaajoul, B.: Sécurité routière au Maroc : Bilan et perspectives, Rapport de la commission économique de l'Afrique, 2009.
- [2] Cascajo, R., Monzon, A.: Rail urban projects: A way for improving public transport patronage, 9th conference on competition and ownership in land transport,

- [3] Risk analysis, driver behaviour and traffic safety at intersections in Motorcycle-Dominated traffic flow, [tuprints.ulb.tu-darmstadt.de](http://tuprints.ulb.tu-darmstadt.de), 28.09.2009
- [4] Saad, F.: In depth analysis of interactions between drivers and the road environment, 4th workshop of international cooperation on theories and concepts in traffic safety (ICTCT), Vienna, pp. 65-79, 1991.
- [5] Salmon, P., Regan, M., Johnston, I.: Human error and road transport: phase two-a framework for an error tolerant road transport system, report, 257, 2006
- [6] Van Eslande, P., Fouquet, K., Michel, J., Fleury, D.: Analyse approfondie de l'accidentologie en aménagement urbain : erreurs, facteurs, contextes de production, Rapport final INREST, 2004
- [7] Van Eslande, P., Fouquet, K.: Analyzing 'human functional failures' in road accidents, Information society technologies, Project No.027763-TRACE, pp 9-15, 2007.
- [8] Salmon, P., Regan, M., Johnston, I.: Human error and road transport: phase one-literature review, report, 256, 2005
- [9] Fleury, D.: Recognition of driving situations and road legibility, 4th workshop of international cooperation on theories and concepts in traffic safety (ICTCT), Vienna, pp. 13-20, 1991.
- [10] Bailly, B.: Conscience de la situation des conducteurs : aspects fondamentaux, méthodes et application pour la formation des conducteurs, thèse de doctorat, spécialité psychologie cognitive, Université LUMIERE Lyon 2, 2004
- [11] Bellet, T., Tattegrain-Veste, H., Chapon, A., Bruyas, M., Pachiaudi, G., Deleurence, P., Guilhom, V.: ingénierie cognitive dans le contexte de l'assistance à la conduite automobile, In Boy (ed), Ingénierie cognitive : IHM et cognition. Hermès, pp. 379-410, 2003
- [12] Bellet, T., Tattegrain-Veste, H.: COSMODRIVE : un modèle de simulation cognitive du conducteur automobile, Formalismes de modélisation pour l'analyse du travail et l'ergonomie, Paris, Presses Universitaires de France, pp. 77- 110, 2003
- [13] Brezillon, J.: Projet ACC : aide à la conduite basée sur le contexte : Etat de l'art, Rapport intermédiaire, LIP6 Université Paris 6, 2006
- [14] Endsley, M., Kaber, D.: Team Situation Awareness for Process Control Safety and Performance, Process Safety Progress, Vol. 17, No. 1, 1998
- [15] Michon, J.A.: Acritical view of driver behavior models: what do we know, what should we do? In L. Evans & R.C. Schwing (Eds.), Human behavior and traffic safety (pp. 485-524). New York: Plenum Press.
- [16] Human Factors and road tunnel safety regarding users, [www.piarc.org](http://www.piarc.org), 01.01.2012.
- [17] Millot, M.: Etude des liens complexes entre forme urbaine et insécurité routière, la collection rapports technique du CERTU, 2004
- [18] Christian, B., Patte, L., Lesage, P., Pouchain, M.: catégorisation des voies urbaines et sécurité routière , note analytique du CERTU, 1997
- [19] Fleury, D.: Etat des recherches sur l'appréhension de la sécurité par le territoire, Colloque AISRE-ASRDLF, 2010
- [20] Pour une approche de la cognition spatiale intra-urbaine , [cybergeog.revues.org](http://cybergeog.revues.org), 27.01.1999.
- [21] Millot, M.: Développement urbain et insécurité routière : l'influence complexe des formes urbaines, thèse de doctorat, spécialité transport, Ecole des ponts et chaussées paris, 2003
- [22] Fleury, D. : Catégorisation des scènes routières et accidents : de l'analyse des accidents aux représentations typiques, Intellectica, 15, pp. 97-123, 1992
- [23] Pouban-Atlas, V. : L'espace urbain déformé : transport collectif et cartes mentales, thèse de doctorat, spécialité transport, Ecole nationale des ponts et chaussée Paris, 1998
- [24] Understanding Human Factors and Developing risk reduction solutions for pedestrian crossing at railway stations, [www.rssb.co.uk](http://www.rssb.co.uk), 01.01.2009





## METHODOLOGY FOR SAFETY PERFORMANCE ASSESSMENT OF HIGHWAY INFRASTRUCTURE – ISSUES, RECENT APPLICATIONS AND FUTURE DIRECTIONS

**Bhagwant Persaud**

*Department of Civil Engineering, Ryerson University, Canada*

### Abstract

The paper addresses key issues in safety performance assessment of highway infrastructure. The state of research in safety performance assessment methodologies in the us, specifically the Highway Safety Manual crash prediction algorithm, is first presented, with an illustration of how the algorithm can be evaluated for application outside the us. Fundamental to the algorithm's performance are crash modification factors (CMFs) for assessing how safety is affected as a roadway feature is changed. Issues in the development of these CMFs are discussed and illustrated with recent application examples in the development of CMFs for countermeasures targeted at improving intersection safety. Finally, the paper discusses future research directions. The paper is a culmination of several recent research projects, some of which are related the Highway Safety Manual, which was released in 2010, and is already being used worldwide.

*Keywords: highway safety, crash prediction models, crash modification factors, Bayesian methods, safety countermeasures*

### 1 Introduction

Explicit consideration of the safety consequences of decisions in designing a new highway facility or in assessing or improving an existing one requires the application of Safety Performance Functions (SPFs) and crash modification factor (CMFs). This is the basic philosophy in the newly released Highway Safety Manual (HSM) [1] which was developed in the United States.

The HSM procedures and associated knowledgebase are of interest around the world, and especially in Europe in the light of the directive (2008/96/EC) recently adopted by the European Commission (EC) that requires the establishment of procedures relating to road safety impact assessments [2]. The HSM will greatly facilitate the EC directive by providing guidance, based on the best available factual knowledge, to professional engineers for quantitative crash analysis and safety evaluation. A key issue in facilitating the worldwide application of the HSM is the transferability of the predictive methodology to data and road networks in environments that may be quite different from those in the us.

Part c of the HSM provides the safety performance assessment algorithm essentials – baseline safety performance functions (SPFs) and CMFs – for segments and intersections for three types of facilities: rural two lane undivided highways, rural multilane highways, and urban and suburban arterials. In the first step of the algorithm, a baseline SPF predicts the expected number of crashes for sites meeting the base conditions. Crash modification factors documented in the HSM are then used to adjust the base SPF prediction to account for the effects of other variables that are subject to design decisions, i.e., for conditions different

from the base conditions. The algorithm provides for the refinement of the estimates using the crash history for an existing site in an empirical Bayes procedure [3], and for adjustments to be made to reflect differences in crash experience across jurisdictions. The algorithm for predicting the number of crashes (N) at a site has the form:

$$N = c \times N_b \times CMF_1 \times CMF_2 \times CMF_3 \times \dots \quad (1)$$

where  $N_b$  is the number of crashes predicted by a SPF for base conditions,  $CMF_1, CMF_2, CMF_3 \dots$  are crash modification factors for differences from the base conditions and  $c$  is a calibration factor for applying a base model from a different jurisdiction and/or time period.

Typically, the base SPF is a function of Annual Average Daily Traffic Volume (AADT), and is calibrated using negative binomial regression modelling that also estimates an overdispersion parameter that serves, among other things, as an indication of how well the model fits the calibration data. The calibration factor can be simply calculated from the total number of crashes for a sample set from the jurisdiction of interest divided by the sum of the predicted crashes for the sample using eqn (1) without the calibration factor.

How well the methodology works for a given jurisdiction anywhere in the world depends on the validity and applicability of its components – the base SPF, the CMFs, and the calibration factor. The rest of the paper touches on issues related to these components. Section 2 addresses the three components as a whole, with a focus on the SPFs, while Section 3 focuses on the CMFs.

## 2 Issues relating to the calibration and application of the HSM crash prediction algorithm outside the US

Issues in the calibration of the HSM crash prediction model were recently investigated in a research project [4] pertaining to its application for two-lane rural roads in Ontario, Canada. This effort served to demonstrate tools that could be used by jurisdictions around the world for assessing the validity and compatibility of the CMFs and base SPFs, as well as the performance of the whole algorithm.

The basic approach was to apply the HSM recalibration procedure and evaluate the performance of the HSM SPFs and CMFs for two-lane when applied to local data from Ontario, Canada. These data included 483 homogeneous segments with the total length of 77.9 km. In this recalibration procedure, the HSM SPFs and CMFs was applied to a group of sites and the calibration factor in eqn. 1 was calculated as the ratio of the sum of crash counts for the calibration data to the sum of the predictions.

Several goodness-of-prediction measures were used to assess performance, including the value of the recalibrated overdispersion parameter, the mean absolute deviation (MAD) (average value of the absolute value of observed minus predicted crash frequencies), and cumulative residual (CURE) plots.

As noted earlier, the overdispersion parameter can be used to compare model performance when applied to the same data in that the smaller its value the better the model is in general. The overdispersion parameter for recalibrated SPFs was estimated using a specially written maximum likelihood procedure.

How well an SPF fits the data can be judged using a Cumulative Residual (CURE) Plot. In this method, the cumulative residuals (the difference between the observed and predicted crashes for each location) are plotted in increasing order for each covariate, e.g., AADT, separately. Also plotted are graphs of the 95% confidence limits. If there is no bias in the SPF, the plot of cumulative residuals should stay inside of these limits. The graph shows how well the SPF fits the data with respect to range for each individual variable of interest.

In addition to evaluating the performance of the predictive algorithms as a whole it was desired to evaluate the performance of the base condition SPFs and CMFs separately. To evaluate the CMFs the following steps were undertaken, where data were sufficient, separately for each CMF in turn:

- Change the CMF to 1 for all sites
- Group the sites by the levels of the CMF in question
- For each group, divide the sum of observed crashes by the sum of predicted crashes, this is a multiplier for each group
- For each group, divide the multiplier by that for the base condition
- Compare the results from the last step to the original CMFs

Application of the algorithm without recalibration resulted in an overestimation of crash predictions for the Ontario data. The calibration factors for adjusting the HSM models to local conditions of the highways of interest are 0.79 for all severity (total) crashes and 0.74 for fatal plus injury (FI) crashes.

The calibration factors were then applied to the HSM algorithm and crashes predicted again. The Goodness–Of–Fit statistics for these recalibrated model predictions are indicated in Table 1. Also provided are the recalibrated overdispersion parameters on a per kilometer basis. An examination of the goodness–of–fit measures indicates that, overall, the recalibrated models perform reasonably well. The values for MAD (Mean Absolute Deviation) are relatively low as are the overdispersion parameters.

Table 2 shows the ratios of observed to predicted total crashes for different values of two variables. The trend is not consistent, although it should be noted that for some categories the number of crashes is small. The results in Table 2 indicate as follows:

- For lane width, the algorithm tends to over–predict for narrower lane widths and under–predict for lane widths of 3.65 m and above.
- For roadside hazard rating there is no evident trend in over or under–prediction.

**Table 1** Goodness–of–fit for Ontario two–lane rural road segments

Observed Crashes		MAD for FI	Calibration Factor		MAD for Total	Recalibrated Overdispersion Parameter	
FI	Total		FI	Total		FI	Total
141	534	0.384	0.74	0.79	1.095	0.11	0.17

**Table 2** Observed and Predicted Crashes vs. Design Features

Design Feature	Value	Observed	Predicted	Observed/predicted
Lane Width	3.35	16	24.64	0.65
	3.50	23	85.74	0.27
	3.60	53	79.81	0.66
	3.65	127	91.83	1.38
	3.75	315	251.98	1.25
Roadside Hazard Rating	1	23	85.74	0.27
	3	164	106.38	1.54
	4	204	240.61	0.85
	5	121	88.61	1.37
	6	22	12.66	1.74



Figure 1 provides example CURE plots for grade and driveway density versus total crashes. For grade, the CURE plot shows significant bias, particularly for positive values of grade, for which the graph strays beyond the upper 2 standard deviation boundary. For driveway density the predictions are reasonable, in that the plotted line is within the 2 standard deviation boundaries.

The results for the Ontario study were consistent with a recent Italian two-lane rural road case study [5]. That effort calibrated a local base SPF and found that the AADT coefficient was significantly larger than the HSM value of 1.0 (which assumes, contrary to most research, that crash frequency is proportional to AADT), so it is not surprising that the relative difference in predictions between the two models increased with increasing AADT. This, and other results, suggests that the implementation of the HSM safety assessment techniques across Europe, now promoted with the adoption of the directive 2008/96/EC, should be oriented towards the developing of local SPFs/CMFs for the European context.

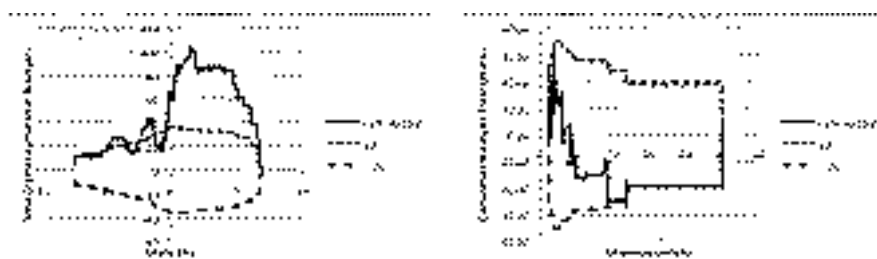

**Figure 1** CURE plots of two-lane rural segments: Grade vs. Total Crashes (left); Driveway Density vs. Total Crashes (right)

### 3 Issues related to the development of CMFs

Key issues in CMF development have been documented in a recent guidebook [6] which first discusses the strengths and weaknesses of the two key methods used for developing CMFs – before–after and cross–sectional studies. Cross–sectional designs compare the crash frequencies of a group of sites with the treatment of interest to similar sites without the treatment at a single point in time and so are particularly useful for estimating CMFs where there are insufficient instances where a countermeasure is actually applied and for the preferred before–after study to be conducted.

The main problem with the before–after design is that the observed change in crash frequencies after a treatment may be due not only to the countermeasure, but to other factors such as changes in traffic volume, crash reporting or weather, and to regression–to–the–mean. Many past studies did not control for these other changes. In the case of regression to the mean, the effects of countermeasures are overestimated since this phenomenon tends to result in reduced crash frequencies when, as is often the case, sites are selected for treatment due to a randomly high crash count [3]. The empirical Bayes methodology [3] resolves the regression to the mean problem with the use of safety performance functions that, conveniently, are also used to account for traffic volume and time trend changes. Another key issue with the before–after design is that typically there are insufficient sample sizes of treatment sites to investigate how the CMF varies with various factors. It is well recognized that many countermeasures are more effective under certain application conditions, so the inability of a before–after design to investigate this variability can be a crucial limitation. Despite its limitations, the cross–sectional design can overcome this limitation.

CMFs derived from cross–sectional data are based on the assumption that the ratio of crash frequencies for sites with and without a feature is an estimate of the CMF for implementing

that feature. The problem with this assumption is that differences in crash frequencies between two groups may be due to factors other than the measure of interest. These other factors may be controlled for by accounting for their effects and that of the measure of interest in a multiple regression model, whereby the coefficient of a variable is indicative of the CMF for a unit change in that variable. The problem with this is that these coefficients will be inaccurate, and perhaps even have the incorrect sign, due to correlated or omitted variables. The result is that CMFs from cross-sectional designs tend to indicate smaller crash reductions than those derived from before-after studies.

#### 4 Illustrative recent application examples in CMF development

Two recent studies [7] [8] pertaining to countermeasures for signalized intersections serve to illustrate the issues discussed above and their resolution.

The first study [7] estimated CMFs from before-after evaluations (using the EB methodology primarily) of two treatments targeted at left turn crashes at signalized intersections: (1) changing from permissive to protected-permissive phasing, and (2) implementation of flashing yellow arrow (FYA) for permissive left turns. Results of the first evaluation, which was based on a total of 71 intersections indicated a substantial reduction in left turn opposing through crashes, especially at intersections where more than one leg was treated, and a small percentage increase in rear end crashes. For the second evaluation (FYA), which was based on data from 51 signalized intersections, results indicated a safety benefit at locations with some kind of permissive left turn operation before, and a disbenefit where there was protected only operation before. A key aspect of the study was the estimation of the standard deviation of the distribution of the CMF. For several CMFs, the standard deviation of the distribution was larger than the standard error of the mean value of the CMF, indicating substantial variation in the treatment effect across sites. This indicates the need for the development of crash modification functions instead of crash modification factors. Equally important, it emphasizes the importance of providing more explicit consideration of CMF variability in future editions of the Highway Safety Manual.

CMF variability can be investigated with caution, as noted earlier, where CMFs are derived from cross-sectional multiple regression models. This was the case for the second illustrative study [8] which also investigated the issue of the compatibility of results from cross-sectional and before-after studies in developing CMFs for two treatments for reducing crashes related to traffic signal change intervals: modifying the change interval (i.e., the yellow and or all-red interval) and installing dynamic signal warning flashers (DSWF). Evaluation methods used included the empirical Bayes (EB) before-after method and cross sectional multiple regression models. A secondary objective of using cross-section models for some evaluations was to examine the comparability of before-after and cross-sectional studies, a subject of topical interest in CMF development. There was a general safety benefit for installing dynamic signal warning flashers, with indications that crash reductions can be obtained overall, and for several crash types, including injury, angle, and heavy vehicle crashes. For the change interval modification, the before-after study results showed significant reductions (at the 5% level) in total, injury, and rear-end crashes under various scenarios. For both treatments, the results from cross-sectional analyses were relatively consistent with those from the before-after analyses. This consistency is of particular interest when comparing the difference in the total change interval. Based on the results of the cross-sectional analysis, there is a u-shaped trend in the expected CMF as shown in Figure 2. Specifically, there appears to be a safety benefit as the difference between the actual and Institute for Transportation Engineers (ITE) recommended change interval [9] approaches zero. (The ITE recommended interval minimizes the dilemma zone that exists where a driver cannot stop safely or proceed through the intersection in the change interval.) The results from the EB analysis also indicated a benefit as the change interval is increased and approaches the ITE recommended one and a less pronounced benefit as the total change interval is increased and exceeds the ITE recommended practice (i.e., a u-shaped trend).

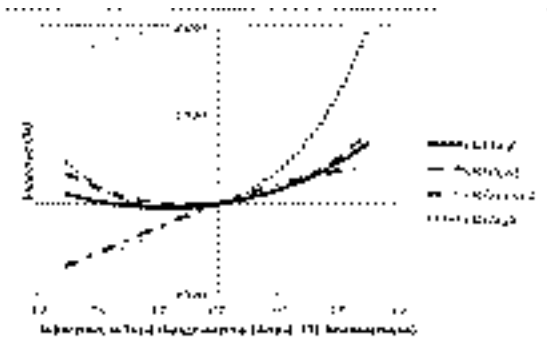

Figure 2 CMF trend for difference between actual and ITE change interval

## 5 Future directions

Methods used for developing CMFs fall under two broad categories: cross-section and before-after studies. The latter type is preferred and many advances have been made, specifically in the application of empirical and Full Bayes methods [3] [10]. Nevertheless, there remains a dearth of knowledge on quality CMFs, largely because existing methods may have reached their limits. As a result, there has of late been renewed interest in enhancing methods for developing crash modification factors, particularly for situations where conventional methods are found wanting. In late 2008, a workshop titled 'Future Directions in Highway Crash Data Modeling' brought together selected, prominent safety researchers to explore promising directions in crash data modeling and to develop a program of advanced safety research that provides a theoretic foundation for explaining crash causation. Goals of the research program recommended at the workshop [11] are to promote the further development of science-based safety evaluation and to facilitate the development of more stable, reliable, and transferrable highway safety predictive models. The call was issued for the development of new methods, and the refinement of existing methods for either quantifying the safety of a facility, or estimating the relationship between a change in facility condition and a change in facility safety. Structural models [12] for explaining crash causation were seen as a promising approach for accomplishing these objectives. Other promising, emerging approaches include Bayesian model averaging [13] and the application of surrogate driver performance measures where there are insufficient data for crash based evaluations. In the latter case, there has been substantial research of late, but establishing a strong relationship between safety surrogates and crashes has, by and large, eluded researchers, as is the defining and developing of surrogates that can be related to crashes, and so more research is needed on the application of this approach safety estimation.

## Acknowledgment

The paper is based on research conducted by the author in collaboration with several colleagues whose names appear on the referenced publications related to these projects. These contributions are gratefully acknowledged as are the funding sources for these projects, including the Natural Sciences and Research Council of Canada, Transport Canada, and Ministry of Transportation, Ontario.

## References

- [1] American Association of State: Highway Safety Manual, 2010.
- [2] European Parliament and Council. Directive 2008/96/EC on road infrastructure safety management. Brussels, Belgium, 2008
- [3] Hauer, E. *Observational Before-After Studies in Road Safety*. Pergamon Press, Elsevier Science Ltd., Oxford, England, 1997.
- [4] Persaud B., Chen Y., Sabbaghi A., & Lyon c. *Adoption of Highway Safety Manual Methodologies for Safety Performance Assessment of Ontario Highway Segments*. Ryerson University. Report for the Ministry of Transportation, Ontario. 2010.
- [5] Sacchi E., Persaud B., & M. Bassani. *Assessing international transferability of the Highway Safety Manual crash prediction algorithm and its components*. Accepted (February 2012) for publication in *Transportation Research Record*.
- [6] Gross F., Persaud B., and c. Lyon. *A Guide to Developing Quality Crash Modification Factors*. U.S. Department of Transportation, Federal Highway Administration Report. FHWA-SA-10-032, 2010.
- [7] Persaud B., Gross F., & R Srinivasan. *Evaluation of two treatments for reducing crashes related to traffic signal change intervals*. Accepted (Feb. 2012) for publication in *Transportation Research Record, Journal of the Transportation Research Board*.
- [8] Srinivasan R., Lyon C., Persaud B., Baek J., Gross F., Smith s. & c. Sundstrom. *Crash modification factors for changing left turn phasing*. Accepted (Feb. 2012) for publication in *Transportation Research Record, Journal of the Transportation Research Board*.
- [9] Institute of Transportation Engineers (ITE): *Recommended Practice: Determining Vehicle Change Intervals*. ITE Technical Committee 4A-16, ITE Journal, Institute of Transportation Engineers, Washington, DC, 1985.
- [10] Park E., Park B. and T. Lomax. 'A fully Bayesian multivariate approach to before–after safety evaluation. *Accident Analysis & Prevention*' 42, Issue 4, pp. 1118-1127, 2010.
- [11] *Theory, explanation, and prediction in road safety*. Task Force for Development of a Highway Safety Manual, Transportation Research Board, Washington, 2009
- [12] Gaudry M. and S. Lassarre. *Structural Road Accident Models The International DRAG Family*. Pergamon Press. 2000.
- [13] Chen Y., Persaud B., and E. Sacchi. *Improving transferability of safety performance functions by Bayesian model averaging*. Accepted (February 2012) for publication in *Transportation Research Record, Journal of the Transportation Research Board*.





## DRIVER'S DISTRACTION AND INATTENTION PROFILE IN TYPICAL URBAN HIGH SPEED ARTERIALS

Eleni Misokefalou, Nikolaos Eliou

*University of Thessaly, Department of Civil Engineering, Greece*

### Abstract

Over the last years, distracted driving constitutes a considerably increasing road safety problem with disastrous results and it possesses a leading position among the accident causes. The present study deals with driver's distraction due to out of the vehicle factors. Considering exterior factors as the most significant, we can group them in four categories: built roadway, situational entities, the natural environment, and the built environment. Regarding the fourth category, it is related to the wide variety of civil infrastructure, the commercial land use combined with high vehicle speed. All these contribute to the setup of a very dangerous environment by increasing driver's distraction and inattention. This research is based on a medium scale experimental procedure. The distraction of the driver's attention is evaluated via a continuous recording of his gaze. The main objective of this paper is to assess the side effects of roadside advertising and overloaded informational signs to driver's distraction and inattention. The results of this type of research procedures are very useful as a tool of prevention of the forthcoming pressure for more and more billboards and trademarks on the roads as well as to encourage the adaptation of more precise regulations with regard to the road infrastructure, the placement of roadside elements, etc.

*Keywords: driving, distraction, advertising, billboards, naturalistic, research*

### 1 Introduction

The distraction of driver's attention during the implementation of the driving task is not simply a theory. It is a procedure which is activated and developed depending on many factors. It is detected in all drivers, with varying extent and frequency of appearance, but, in every case, the results of this distraction are intense for the driving task, the driver's safety and, finally, for the rest of road users. Distraction, at all forms, has recently become an object of research, with distraction from a secondary task concentrating most of the research on the subject, particularly after the widespread use of mobile phones and the integration of driver assistance systems in modern vehicles. Naturally, priority is given to drivers of passenger cars without overlooking the other road users' categories such as truck drivers, motorcyclists, bicyclists etc [1].

#### 1.1 Definition and characteristics of driver distraction

The first step to a proper approach is to understand the basic characteristics of a distraction as it appears in general. Distraction may be visual, cognitive, biomechanical and auditory [2]. In the first International Conference on Distracted Driving (2005) the scientific community agreed on a definition for distracted driving: 'Distraction involves a diversion of attention from driving because the driver is temporarily focusing on an object, person, task, or event not rela-

ted to driving, which reduces the driver's awareness, decision-making, and/or performance, leading to an increased risk of corrective actions, near-crashes, or crashes' [3]. The main causes of distraction are classified into two categories: Those coming from the interior of the vehicle and those from the external environment. In the second category, one finds some very important potential sources of driver distraction. In the case of causes related to advertising, it should be particularly emphasized that the purpose of their presence at some point at the roadside, or even in a moving vehicle in the road, is to capture the driver's gaze in order for him/her to devote the required time so as to assimilate the information obtained. Roadside advertising billboards are designed by their very nature to attract attention. Crucially, though, the related potential threat to road safety is generally not acknowledged by the industry [4].

## 1.2 Frequency of driver distraction

The importance of this issue emerges from data which shows distraction from a secondary task as a cause of serious accidents as well as crashes. A characteristic research was carried out by the Virginia Tech Transportation Institute (VTI) for NHTSA, the '100-Car Naturalistic Driving Study' [5]. During the 100-Car Naturalistic Driving Study, driver involvement in secondary tasks contributed to over 22 percent of all crashes and near-crashes recorded during the study period. These secondary tasks, which can distract the driver from the primary task of driving (steering, accelerating, braking, speed choice, lane choice, manoeuvring in traffic, navigation to destination, and scanning for hazards), are manifold and include such things as eating/drinking, grooming, reading billboards, using and adjusting in-vehicle entertainment devices, conversation with passenger(s), viewing the scenery, tending to children and pets, smoking, cell phone use and related conversation, use of other wireless communication devices, and note-taking, to name a few [3]. Not all distracters involve secondary tasks initiated by driver – they can be events, objects, activities or people both inside/outside the vehicle [6]. At this point it should be noted that, as near crash is defined the subjective judgment of any circumstance that requires, but is not limited to, a rapid, evasive manoeuvre by the subject vehicle, or any other vehicle, pedestrian, cyclist, or animal to avoid a crash [5]. The statistics are confirmed by the data from accidents in many countries (e.g. accident data from United States in 2008 (NHTSA, 2009) and Greek Police for 2009 and 2010 [7]).

Particularly for billboards, Crundall et al. study [4] supports that though it is acknowledged that research into advertisement distraction has been extremely limited [8], the few studies that have been conducted have demonstrated that drivers do look at and process roadside advertisements [9], and that fixations upon advertisements can be made at short headways or in other unsafe circumstances [10]. Previous studies of accident statistics have also identified external distractors, including advertisements, as a significant self-reported cause of traffic accidents [11]. Particularly, for roadside distractors, evidence is mounting that roadside distractions (and advertising in particular) present a 'small but significant' risk to driving safety [12]. Conservative estimates collated from a review of several accident databases put external distractors responsible for up to 10% of all accidents [13]. This is confirmed also by a recent simulator study [14] in which there is a tentative suggestion that more crashes occur when billboards are present.

## 1.3 Methods of evaluating driver distraction

The only certain way for the researcher to detect driver's distraction is via the results that distraction produces. The use of standardized methods gives the researchers the possibility to exchange data, conclusions and best practices [15]. Therefore, it is important to detect the most suitable method of data collection [16]. This aim can be achieved via a comparative study between the allocated methods, examining the advantages and disadvantages of

every method separately as well as the usefulness and necessity of the results that every one of them produces. An analysis of this kind was made in the study of Eliou and Misokefalou [15]. The most popular among the available methods are based on elements of accidents, on experiments, on observation and surveys. Furthermore, there are some kinds of methods that are not included in any of the previous categories like Peripheral Detection Task and Visual Occlusion.

## **2 Method**

### **2.1 Selection of the appropriate method**

The method considered the most appropriate is an observational–naturalistic study, which takes place in the field, using specially equipped vehicles. The objective is to record the driver's eye movements in order to measure the frequency and the duration of the glances at every object considered a potential source of visual distraction. The available equipment (Facelab machine) is capable of making continuous data recording. The main advantage is that with this method, in contrast with all the others categories, driving comes as close to the real thing as possible which is important for the research when we study human reactions. Naturally, there are some limitations both in designing and carrying out the experiment. The most important of these is the limited number of participants in comparison with other methods like questionnaires study, the unfamiliar vehicle which causes stress to the driver, the anxiety because of the sense of being monitored as the vehicle is equipped with cameras and, finally, the subjective discretion of the analyst–observer at the data processing.

Captiv software, which is compatible with FaceLab L2100, was used for the analysis of the results. This software gives the opportunity to analyze the data in detail by recording the total time that the billboard captured driver's gaze during driving. At this point it should be noted that as a distraction, in this study, the continuous or intermittent but repeated capture of the gaze from a theme for longer than total of two seconds are considered, as glances that last more than this time are related to driving errors [16].

### **2.2 Participants**

Using volunteer drivers, who were required to drive a car on the Thessaloniki's Ring Road, under the supervision of the researcher, who was always in the passenger seat checking the proper function of the system, the obtained results are characterized by a high degree of reliability and validity. Ten drivers (mean age =28.3 years, range = 25 to 30 years) participated in the survey (7 males, 3 females). The drivers were selected by age criterion. All drivers were familiar with the road, as they use it on a daily basis, but the subject of the study was completely unknown to them. Each of them, in order to become familiar with the vehicle, drove the selected route 2 times before the third run which was the one that we focused our attention at during the analysis process.

### **2.3 Experimental site**

The research took place from January 2010 to April 2010, in Thessaloniki's Ring Road, which is a suburban road. The route under observation has a total length of 12.5 km and 12 intersections. For the purpose of the research, drivers drove both directions of the total of 12,5km. The flow of vehicles is continual without being interrupted by traffic lights. The speed limit of the road is 90km/h. The most significant problem of the road is the speed of the passing vehicles in relation to the road geometry as well as the absence of an emergency lane [17].



## 2.4 Material – Data collection

The equipment used in the survey was very carefully chosen in order to produce the optimal quality, completeness and integrity of results. It includes a passenger vehicle and a monitoring and recording system, which detects and records every single movement of the driver's gaze and the driver's head. It is composed of two cameras for the recording of the above, and an external camera for the recording of the road scene. All measurements for the experiment took place during the day, under normal traffic conditions as well as normal weather and lighting conditions.

## 3 Results

In this study, the information isolated and analyzed in depth, is related to the external impulses that cause driver distraction and concentrates interest mainly on billboards near the road and the role of their position in driver's distraction of attention. For this purpose, all billboards along the road were identified and mapped for both directions of the route. Additionally, we noticed a section at a specific junction of the Ring Road, where a large number of illegal posters are placed in disorder which, at first view, leads to a sharp visual disturbance (marked as advertisement billboard number 8 and 20). The analysis included an examination of driver behaviour, meaning the reactions of drivers' pupils while driving under the existence of these potentially evocative distraction elements of the road environment [18].

The following Fig. 1 shows the percentages from the analysis of the gaze direction to the advertisement billboards of the route. Each driver drove the selected route 3 times but we decided to focus our attention at the third one, because of the familiarization of the driver with the vehicle which we analyzed at the method section. As it shows, distraction from advertisement billboards possesses a high percentage of the driving time which ranges from 6 to 8.85% with an average of 7.84%.



Figure 1 Percentage of driving time looking at advertisement billboards

The detailed analysis of the data came from the eye gaze, in terms of glance duration and frequency, and has led us to the following conclusions:

- All roadside billboards of the route distract the majority of the drivers (gaze captured for more than 2 seconds).
- At the route points with many placed billboards, in a short distance (e.g. advertisement billboard number 9 and 21), the majority of drivers are distracted as their gaze is captured by more than one billboard. At these points, intermittent but repeated capture of the drivers' gaze is observed.
- Billboards attract women's gaze more than men's. The average percentage of the total time that women look at advertisement billboards is 8.7%, while for men it is 7.5%.
- The billboards found in the centre or near the central field of vision are more likely to attract the driver's gaze.
- At the section which contains a high gather of posters placed in disorder, a large number of illegal posters attract multiple glances from drivers so that the visual disturbance leads to confusion.
- During the third route, 50 percent of drivers' gaze is captured by more advertisement billboards than during the first route.
- Fig. 2 obviously shows that there are certain advertisement billboards that capture drivers' gaze during all three rides. The percentage of billboards that capture drivers' gaze mostly at the second and the third route is limited.

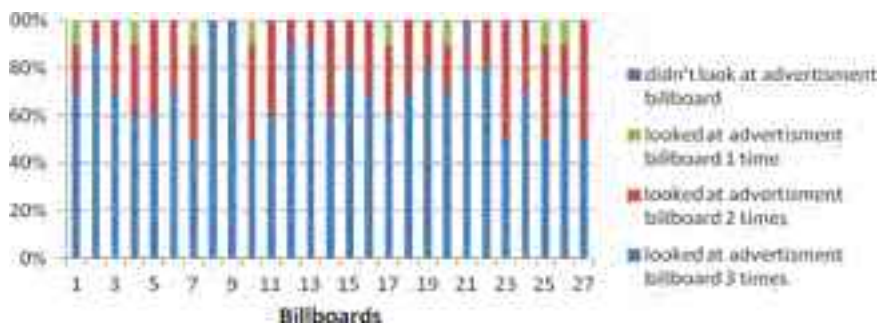

**Figure 2** Percentages of drivers distracted from billboards at all three, at two, at one and at none of the routes

From the survey a result arises that the presence of distraction, and more specifically the one caused due to billboards, is common in drivers and depends largely on the characteristics of the billboards and their position in the field of vision.

## 4 Discussion

Distraction of driver's attention during driving is a major road safety problem, which threatens not only the driver's safety but also the safety of other drivers and road users. The focus of the research on drivers of passenger vehicles is due to the fact that those drivers constitute the largest category of road users with growing involvement in accidents, which are caused by the distraction of driver's attention. The goal of the research is to identify and clarify the causes, the frequency of appearance and the way that certain factors influence the distraction of attention of each driver, focusing on the role played by roadside advertising in Greece as a parameter of the distraction of the driver's attention.

The methods commonly used in a study of driver distraction aren't all feasible or effective to the same extent. The chosen method allows continuous data recording with its main advantage being the fact that driving is as close to the real thing as possible. Thus, the results are characterized by a high degree of reliability and validity. It, also, gives the opportunity

to the participant to have an adjustment period with the vehicle in order to obtain a normal driving behaviour. The small possibility of the researcher to control the situations and create desirable driving scenarios is among the disadvantages of this method. The environmental conditions, also, cannot be controlled. Another disadvantage is the increased cost of the method due to the eye tracker. Finally, as a disadvantage of the eye tracker we could mention the difficulty of the car installation, as well as its sensitivity to changes (e.g. light conditions). This research concluded that all roadside billboards of the route distract the majority of the drivers, with signs in the raw causing a greater distraction. Also, the more centrally positioned in the field of vision the signs are placed, the more eye-catching they are. There is a need to relate the drivers' distraction to specific aspects of advertising signs (size, message content, position by the road).

Much of the data analyzed requires collaboration with experts such as psychologists and doctors in order to provide an integrated approach. Furthermore, a comprehensive policy to reduce the visual pollution near roads, such as billboards, can help not only to improve the road aesthetic but also to significantly improve road safety by eliminating driver's visual distraction of attention [1].

To sum up, it is a fact that driver distraction is a major cause of accidents; therefore, the responsibility over the issue translates into efforts to reduce the number of injured and dead drivers. This research will be extended, in the future, to Urban Freeways in the major Greek cities (Athens and Thessaloniki). The same experiment is already in progress in Athens, with a sample of 20 participants.

## References

- [1] Misokefalou, E., Eliou, N. & Galanis, A.: Driving distraction of attention audit of motorcycle and bicycle users in urban areas, Case study in the city of Volos, Greece, 5th international congress on transportation research, Volos, Greece, 2010.
- [2] Ranney, T.A., Garrott, W.R. & Goodman, M.J.: National Highway Traffic Safety Administration driver distraction research: past, present and future, 17th International Technical Conference on Enhanced Safety of Vehicles, Amsterdam, 2001.
- [3] Hedlund, J., Simpson, H.M. & Mayhew, D.R.: International conference on distracted driving-summary of proceedings and recommendations, International Conference on Distracted Driving, Toronto (2–5 October 2005), 2006.
- [4] Crundall, D., Van Loon, E. & Underwood, G.: Attraction and distraction of attention with roadside advertisements, *Accident Analysis & Prevention*, 38, 671–677, 2006.
- [5] Klauer, S.G., Dingus, T.A., Neale, V.L., Sudweeks, J.D & Ramsey, D.J.: The impact of driver inattention on near-crash/crash risk: an analysis using the 100-car naturalistic driving study data, Report No. DOT HS 810 594, National Highway Traffic Safety Administration, Washington, D.C, 2006.
- [6] Tasca, L.: Driver distraction: towards a working definition, International Conference on Distracted Driving, Toronto (2–5 October 2005), 2005.
- [7] Greek Police: Accident Statistics for the Year 2011, Ministry of Citizen Protection, Greece, 2011.
- [8] Beijer, D.D., Smiley, A. & Eizenman, M.: Observed driver glance behavior at roadside advertising signs, *Transport Research Record*, 1899, 96–103, 2004.
- [9] Hughes, P.K. & Cole, B.L.: What attracts attention when driving?, *Ergonomics*, 29, 311–391, 1986.
- [10] Smiley, A., Smahel, T. & Eizenman, M.: Impact of video advertising on driver fixation patterns, *Transport Research Record*, 1899, 76–83, 2004.
- [11] Stutts, J.C., Reinfurt, D.W., Staplin, L.W. & Rodgman, E.A.: The Role of Driver Distraction in Traffic Crashes, AAA Foundation for Traffic Safety, Washington, DC, 2001.
- [12] Lay, M.G.: Design of traffic signs. In C. Castro & T. Horberry (Eds.), *The human factors of transport signs*, 25–48, Boca Raton, FL: CRC Press, 2004.

- [13] Wallace, B.: Driver distraction by advertising: Genuine risk or urban myth?, *Municipal Engineer*, 156, 185–190, 2003.
- [14] Young, K., Mahfoud, J.M., Stanton, N. A., Salmon, P.M., Jenkins, D.P. & Walker, G.H.: Conflicts of interest: The implications of roadside advertising for driver attention while driving: Skill and awareness during inspection of the scene, *Transportation Research Part F* 12, 381–388, 2009.
- [15] Eliou, N. & Misokfalou, E.: Comparative analysis of drivers' distraction assessment methods, 22nd ICTCT Workshop, Towards and Beyond the 2010 Road Safety Targets-Identifying the Stubborn Issues and their Solutions, Leeds, UK, 2009.
- [16] Rockwell, T.H.: Spare visual capacity in driving- revisited, In A.G. Gale, H.M. Freeman, C.M. Haslegrave, P. Smith & S.P. Taylor (Eds.) *Vision in Vehicles II*, 317-324. Amsterdam: Elsevier, 1998.
- [17] Atzemi, M.: Quality assessment of the internal and eastern Thessaloniki's Ring Road, Diploma thesis in the program of postgraduate courses engineering project management, Department of Civil Engineers, Aristotle University of Thessaloniki, Greece, 2007.
- [18] Chrisostomou, K.: Investigation of driver distraction of attention, Diploma thesis in the program of postgraduate courses design, organization and management of systems of means of transport, Department of Civil Engineers, Aristotle University of Thessaloniki, Thessaloniki, 2010.





## SIGHT DISTANCE TESTS AT ROAD INTERSECTIONS WITH UNFAVOURABLE ANGLES

Ivica Stančerić, Željko Korlaet, Vesna Dragčević

*Faculty of Civil Engineering, University of Zagreb, Croatia*

### Abstract

Due to the limited field of view of the driver on the secondary road safety assessment capabilities of performing the desired action of turning and crossing at the road intersections with unfavourable angles ( $< 70^\circ$  and  $> 110^\circ$ ) becomes uncertain. Since all the intersections from the standpoint of traffic safety services must have sufficient sight distance at the road intersections with unfavourable angles it is common to perform reconstruction of the secondary road axis, so that main and secondary road axis intersects at approximately right angle.

This paper will present how sight distance tests based on measurements of the driver visual field from different types of vehicles (passenger car and heavy vehicles) were performed on the road intersections with unfavourable axis angles. Test results will show for which road intersection angles it is possible to keep the secondary road axis in the direction, without the need for reconstruction.

*Keywords: intersections, sight distance, driver field of view*

### 1 Introduction

The main goal in designing road intersections is safe and undisturbed traffic flow as well as the rational utilization of surfaces. One of the prerequisites for the safe traffic flow at intersections is ensuring sufficient sight distance. Ensuring sight distance at intersections is achieved by additional berm widening, land reclamation and prohibition of construction of buildings so that nothing can encroach upon the space bounded by sight distance triangle. In addition to the mentioned research other studies [1, 2, 3, 4] have shown that at-grade intersections with intersection angles smaller than  $70^\circ$  and bigger than  $110^\circ$  limited field of view from the vehicle should also be taken into consideration in sight distance testing. Limited field of view from the vehicle at skewed intersections is mostly influenced by human factors (driver's field of view) and construction properties of the vehicle. The negative consequence of the limited field of view from the vehicle is manifested in the fact that the driver on the minor road at intersections with a skew angle cannot estimate well if the vehicles on the major road are at the sufficient distance for the safe performance of the required traffic maneuver. The usual procedure for solving this problem in designing practice comes down to the reconstruction of minor road axis so that it crosses the major road axis at approximately right angles [5, 6]. However, if the reconstruction of minor road axis is not possible due to space restrictions it is important to determine minimum ( $< 90^\circ$ ) and maximum ( $> 90^\circ$ ) intersection angles that allow minor road axis to be in the direction ensuring the safe traffic flow at the intersection.

## 2 Sight distance testing

Sight distance tests at four-leg intersections with a skew angle was based on testing visibility from the vehicle aimed at determining minimum ( $< 90^\circ$ ) or maximum ( $> 90^\circ$ ) allowable intersection angles up to which it is possible to keep minor road axis in the direction. Due to different factors that influence the visibility from the vehicle, sight distance testing is divided into two parts:

- for intersection angles  $> 90^\circ$  (influence of the vehicle cabin B – pillar),
- for intersection angles  $< 90^\circ$  (influence of the driver's field of view and driver's head rotation angle).

In order to test the visibility from the vehicle three European vehicles were chosen:

- passenger car – brand vw, model Golf VI,
- van (maximum allowed mass  $\leq 3.5$  t) – brand vw, model Transporter,
- truck tractor (maximum allowed mass  $\leq 16,0$  t) – brand MB, model Actros.

Test vehicles were selected according to the availability criteria and the number of sold (newly registered) vehicles in Europe. According to the Jato Dynamics data [7] vw – Golf VI was the most sold vehicle on the European market in 2009 and 2010. vw – Transporter was used in testing for the reason of its availability (owned by the Department for Transportation of the Faculty of Civil Engineering in Zagreb), and Actros was chosen for the fact that in 2010 MB vehicles were leading according to the number of newly registered heavy vehicles in the European union [8].

### 2.1 Sight distance testing at intersections with intersection angles bigger than $90^\circ$

Sight distance tests started with measuring the driver's field of view from the vehicle in the similar way as in the previous researches [1, 2]. Measurements of the driver's field of view (VA) were conducted from test vehicles for three different head positions:

- 1 the driver's head leaned against the back of the seat (SB – sit back),
- 2 comfort position of the driver's head, the usual position in driving (CP – comfort position),
- 3 the driver's head leaning towards the steering wheel (LF – lean forward).

The procedure of measuring the driver's field of view came down to measuring the visibility angle (VA) between the two looks, the straight ahead look and look to the right, by means of measuring battens. Figure 1. shows the position of battens for measuring visibility angle (VA) on the van.

Visibility angle measurement started with positioning batten 1 vertically on batten 3 (at the center of the driver's head when looking to the right), on the external part of the vehicle (Figure 1). By positioning batten 2 on the floor (perpendicular to batten 3) at the same position with the batten 1 and the driver's eyes, the position of the driver's eyes was transferred to batten 4. In that way the start position of batten 1 was defined on batten 4. The end position was obtained by moving batten 1 backwards on batten 4 all the way to the position in which the driver could see batten 1 in its full width through the right window of the vehicle. The move of batten 1 from the start to the end position was measured by the measuring band placed on batten 4. Visibility angle  $VA_1$  was calculated on the basis of the move of batten 1 on batten 4, the distance between battens 3 and 4 (3.0 m) and the distance between the driver's eyes and batten 1, while total visibility angle VA equals the value of  $VA_1$  increased by  $90^\circ$ .

The described procedure of measuring the visibility angle ( $VA_1$ ) from the vehicle was done on ten drivers on all test vehicles and for all three head (eye) positions. The blueprints of test vehicles (driver's cabs) [9, 10] were used as help in determining the visibility angle. Mean values of the measured visibility angles (VA) from Table 1 show that the best visibility from the vehicle is achieved when the driver's head leaning towards the steering wheel and the worst when the driver's head leaned against the back of the seat.

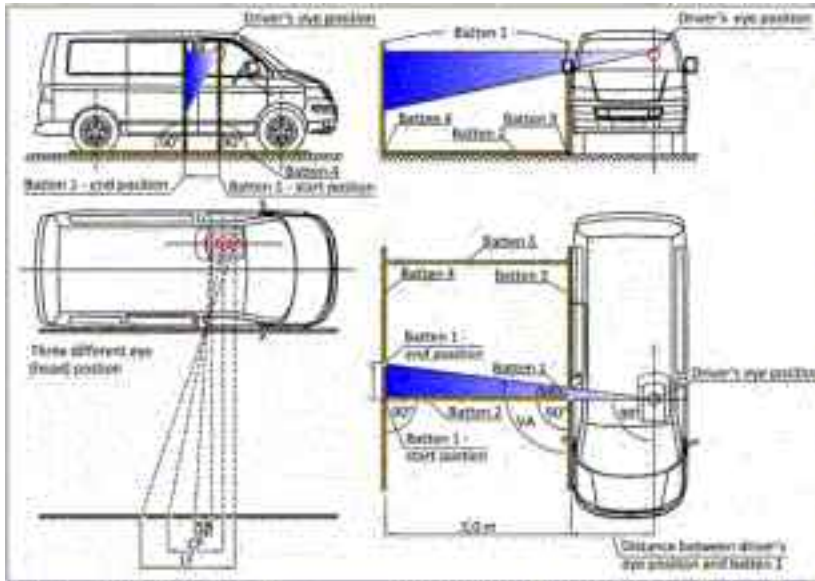
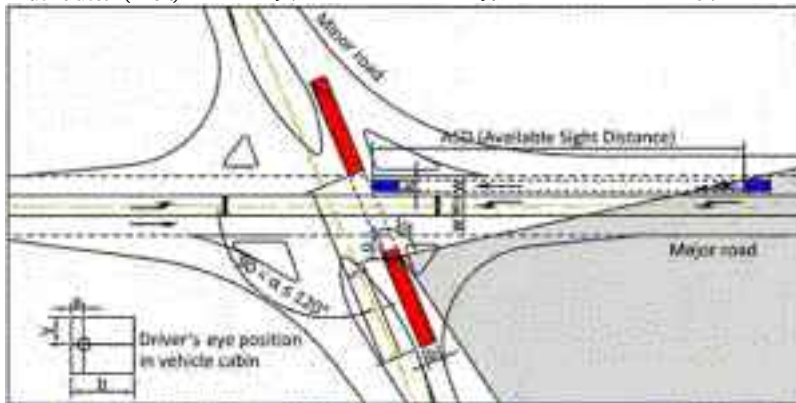

**Figure 1** Schematic illustration of measuring the visibility angle (VA) from the vehicle (VW Transporter)

In order to determine the available sight distance (ASD) on the basis of visibility angles from Table 1 the scheme of four-leg channelized intersection at grade (Figure 2) with three 3.25 m wide traffic lanes on the major road (two through-traffic lanes and one for the left turn) was drawn.

**Table 1** Mean values of the measured visibility angle (VA) on test vehicles

Vehicle type	VA - visibility angles [°]		
	$VA_{SB}$	$VA_{CP}$	$VA_{LF}$
Passenger car	94	99	110
Van ( $\leq 3,5$ t)	94	98	108
Truck tractor ( $\leq 16$ t)	94	97	104



**Figure 2** The scheme of the intersection for the calculation of available sight distance (ASD)



The scheme of the intersection (Figure 2) shows the position of the vehicle on the major and minor road, the driver's visibility angle from the vehicle ( $\alpha$ ), the available sight distance (ASD) and the path ( $s$ ) which the vehicle has to pass across the major road. The position of the vehicle on the minor road is defined by the distance of the driver's head from the major road edge and the position of the driver's eye (head) in the vehicle ( $x$ ,  $y$ ), while the position of the vehicle on the major road is determined on the basis of the visibility angle ( $\alpha$ ) from the minor road vehicle. The dimensions of the vehicle and the position of the driver's eye are given in Table 2. For the purpose of setting the minimum and maximum allowable intersection angle of crossing roads a semi-trailer was added to the truck tractor so that the total length of the vehicle was 16.5 m (Table 2).

Available sight distance (ASD) is the distance between two positions of the vehicle on the major road, the initial determined by the visibility angle, and the final which is the crossing point of the trajectories of the vehicles from the major and minor road (Figure 2). Since the available sight distance does not depend only on the visibility angle but also on the driver's eye position (the bigger the distance from the major road edge the bigger is the available sight distance) for calculating the available sight distance it was determined that the driver's head is 3.0 m away from the edge of the major road. The driver's head (eye) distance from the traffic lane edge was taken over from the German [5] and Austrian [11] guidelines for the situation when the vehicle stops on the minor leg before entering the intersection.

**Table 2** Table 2. The driver's eye position in the vehicle and the vehicle dimensions

Vehicle type	Driver's eye position in vehicle ( $x$ , $y$ ), vehicle width ( $b$ ) and length ( $l$ ) [m]					
	$x$	$y_{SB}$	$y_{CP}$	$y_{LF}$	$b$	$l$
Passenger car	0,54	2,24	2,15	1,92	1,78	4,20
Van ( $\leq 3,5$ t)	0,55	2,00	1,90	1,69	1,90	4,89
Semi-trailer truck ( $\leq 40$ t)	0,52	1,12	1,03	0,78	2,50	16,50

On the basis of the data on visibility angles, the position of the driver's eye and the intersection geometry the available sight distance was calculated using following formula:

$$ASD = (o + 2w - w_{lt} - \frac{w-k}{2}) / \operatorname{tg}(\alpha - VA) + (o + 2w + w_{lt} - \frac{w-k}{2}) \cdot \operatorname{tg}(\alpha - 90^\circ) - (\frac{b-x}{2\cos(\alpha - 90^\circ)}) - k \cdot \operatorname{tg}(\alpha - 90^\circ) \quad (1)$$

where:

$\alpha$  – intersection angle (Figure 2): 90 - 120°,

$b$  – vehicle width (minor road) (Table 2) [m],

ASD – available sight distance [m],

$k$  – vehicle width (major road): 1,8 m,

$o$  – driver's eye (head) distance from the traffic lane edge: 3,0 m,

$w$  – major road through-lane width [m],

$w_{lt}$  – left turn lane width [m],

VA – visibility angle (Table 1) [°],

$x$  – driver's eye position in vehicle (Figure 2, Table 2) [m].

Since the minimum or maximum allowable intersection angle of crossing roads could not be determined only according to the data on available sight distance, stopping sight distance (SSD) had to be set so that the available sight distance could be compared to something. For determining the stopping sight distance it was necessary to calculate the path length ( $s$ ) and

the time (t) the vehicle needed to cross the major road. To calculate the path length depending on the intersection angle the following formula was used:

$$s = (o + 2w + w_{lt}) / \cos(\alpha - 90^\circ) + l - y + x \cdot \operatorname{tg}(\alpha - 90^\circ) \quad (2)$$

where:

$\alpha$  – intersection angle [°],

l – vehicle length (minor road) [m],

o – driver's eye (head) distance from the traffic lane edge [m],

s – path [m],

w – major road through lane width [m],

$w_{lt}$  – left turn lane width [m],

x, y – driver's eye position in vehicle (Figure 2, Table 2) [m].

The time (t) calculation was based on the hypothesis that vehicles move along the road (path) with constant acceleration from the moment the drivers estimate that the situation on the major road is favorable for performing the necessary traffic maneuver. For time calculation the following formula was used:

$$t = \sqrt{\frac{2s}{a}} + t_r \quad (3)$$

where:

a – acceleration 1,5 m/s<sup>2</sup> → passenger car,

1,25 m/s<sup>2</sup> → van (≤ 3,5 t),

0,7 m/s<sup>2</sup> → semi-trailer truck (≤ 40,0 t),

s – path [m],

t – time needed for the vehicle to cross the major road [s],

$t_r$  – reaction time: 2 s.

The obtained time data (t) were used to calculate stopping sight distance (SSD) for the different driving speed on the major road using following formula:

$$SSD = \frac{V \cdot t}{3,6} \quad (4)$$

where:

SSD – stopping sight distance [m],

t – time needed for the vehicle to cross the major road [s],

V – driving speed on the major road: 20 - 100 [km/h].

Following the example of the research [2] on the basis of the obtained data on the available (for the three driver's head positions – SB, CP, LF) and stopping sight distance (for different vehicle speed on the major road) for intersection angles from 90 to 120° nomographs were made (Figures 3, 4). Nomographs were used to determine the maximum allowable intersection angles (> 90°) separately for each vehicle based on the relevant speed of 40 and 80 km/h. The speed of 40 km/h was selected as legally [12] minimum speed limit on all roads, and the speed of 80 km/h as the highest vehicle speed on intersections at grade. Based on the selected speed criteria for driver's different head positions, minimum or maximum allowable intersection angles (> 90°) for all vehicles were determined (Table 3). The minimum allowable intersection angle of 97° was obtained for semi-trailer truck and the speed of 80 km/h, while the maximum angle of 120° was obtained for passenger vehicle and the speed of 40 km/h (Figure 3, 4, Table 3). The obtained results are logical with regard to the visibility from the vehicle as well as the vehicle performance and dimensions.

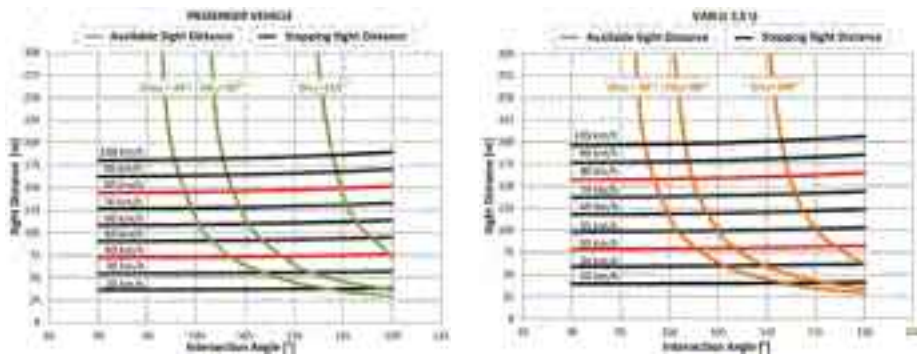

Figure 3 Sight distance nomographs for passenger car and van ( $\leq 3,5$  t)

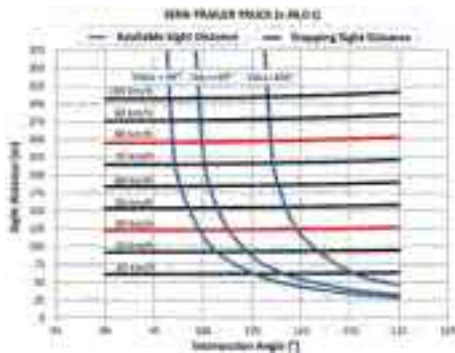

Figure 4 Sight distance nomograph for semi-trailer truck ( $\leq 40,0$  t)

Table 3 Allowable intersection angles for relevant speed and different visibility angles

Vehicle type	Allowable intersection angles [°]					
	$VA_{SB40}$	$VA_{CP40}$	$VA_{LF40}$	$VA_{SB80}$	$VA_{CP80}$	$VA_{LF80}$
Passenger car	103	108	120	99	104	115
Van ( $\leq 3,5$ t)	103	107	117	98	102	112
Semi-trailer truck ( $\leq 40,0$ t)	99	102	109	97	100	107

## 2.2 Sight Distance Testing at Intersections with Intersection Angles Smaller than $90^\circ$

Sight distance tests at intersections with intersection angles smaller than  $90^\circ$  started with determining the driver's field of view and the head rotation angle since these are the main parameters that influence the visibility from the vehicle. In addition to the fact that the mentioned parameters influence the visibility from the vehicle they also directly influence the available sight distance at intersections which is the basis for determining minimum or maximum allowable intersection angles of crossing roads.

Data on the driver's field of view (Figure 5) were taken over from the Directive 2009/113/EC [13] and the Croatian book of regulations [14], based on which the field of view width should be:

- minimum  $120^\circ$  for non-professional drivers: M, A1, A2, A, B, B+E and F category,
- minimum  $160^\circ$  for professional drivers: M, A1, A2, A, B, B+E, C1, C, C1+E, C+E, D, D+E, F, G and H category.

The data regarding the driver's head rotation angle were taken over from the research carried out by Isler et al. [15]. They showed that the minimum head rotation mean value in male and female drivers of all ages (from < 30 to > 70 years) is approximately 60° (Figure 6). However, the sample on which the driver's head rotation testing was done can hardly be considered representative since the graph (Figure 6) shows a lot of illogicality. For example, in female drivers head rotation decreases as their age increases, while it is not the case in male drivers, so it turns out that male drivers aged 60-69 can turn their head more than those aged 40-59. Regardless of the fact that drivers' head rotation measurement was not conducted on the representative sample, driver's head rotation angle of 60° was selected as a relevant angle for available sight distance calculation as a kind of a guarantee that this selection takes into consideration capabilities of all drivers regardless of age or gender.

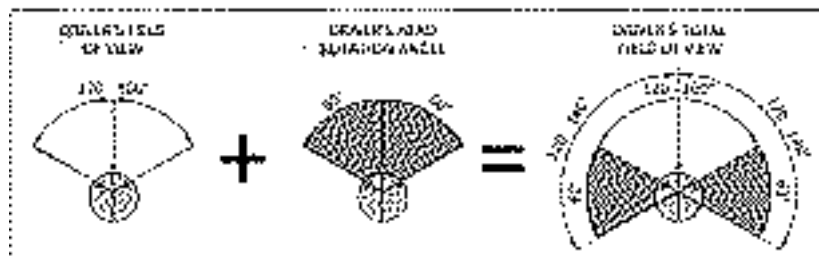

Figure 5 Figure 5. Driver's total field of view

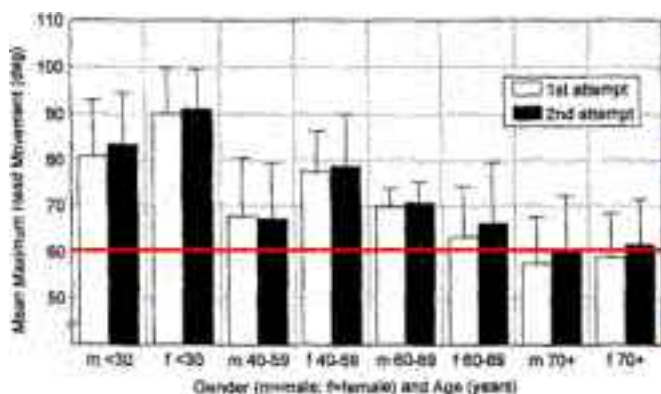

Figure 6 Figure 6. Mean values of the driver's maximum head rotation according to age and gender [15]

The total driver's field of view of 240° to 280° was obtained by adding input data of driver's field of view and head rotation angle (Figure 5). For the calculation of the available sight distance from the driver's total field of view only the part of 120 to 140°, which refers to the driver's look on the left, was taken into consideration. The determination procedure of the driver's left visibility angle (VA) came down to adding half of the field of view from the book of regulations [14] and the Directive [13] and one of the selected driver's head rotation angles (Table 4). Combinations of the driver's fields of view and head rotations were done for all three test vehicles (Figure 5, Table 4) and called driver's visibility angle (VA). Based on the data from Table 4 and the intersection scheme from Figure 7, it was concluded that the obtained combination of field of view and head rotation provides the driver of semi-trailer truck with enough visibility at intersections with intersection angles between 45 and 90°. Thus, semi-trailer truck was excluded from further procedure of determining minimum intersection angles.

**Table 4** Driver's visibility angles when looking to the left (VA)

	Vehicle type	
	Passenger car and van ( $\leq 3,5$ t)	Semi-trailer truck ( $\leq 40,0$ t)
Head rotation angle [°]	60	60
Driver field of vision [°]	60	80
VA – visibility angle [°]	120	140

In order to calculate the available sight distance on the basis of visibility angles (VA) from Table 4, the scheme of four-leg intersection at grade (Figure 7) was drawn with three 3.25 m wide traffic lanes on the major road (two through-traffic lanes and one for the left turn). In addition to traffic lanes and islands the intersection scheme contains also the vehicles on the major and minor road, as well as the driver's visibility angle from the vehicle (VA), available sight distance (ASD) and path (s) which the vehicle needs to pass across one major road lane. The position of the vehicle on the major road was determined by the visibility angle from the vehicle on the minor road, and the position of the vehicle on the minor road by the distance of the driver's eye (head) (o) from the major road lane edge. In order to calculate the available sight distance relevant visibility angles from Table 4 were measured from the comfort position (CP) of the driver's head in the cab (Table 2, Figure 7).

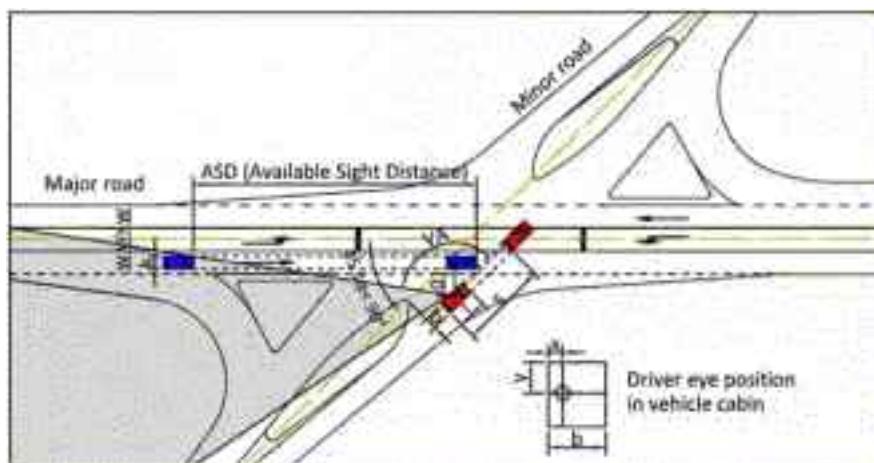

**Figure 7** Figure 7. Intersection scheme for available sight distance calculation (ASD)

Available sight distance (ASD) is the distance between two positions of the car on the major road, the first determined by the visibility angle (VA) and the second on the spot where trajectories of the vehicles on the major and minor road cross (Figure 7). The distance of the driver's eye from the major road lane edge is 3.0 m (Section 2.1). The available sight distance was calculated on the basis of the data on visibility angles (Table 4), the driver's eye position and the intersection geometry (Figure 7) using the following formula:

$$ASD = (o + k + \frac{w - k}{2}) / \operatorname{tg}(180^\circ - \alpha - VA) + (o + \frac{w - k}{2}) \cdot \operatorname{tg}\alpha - \frac{x}{\sin\alpha} \quad (5)$$

where:

$\alpha$  – intersection angle [°]

ASD – available sight distance [m]

k – major road vehicle width: 1,8 [m]

o – driver's head (eye) distance from the traffic lane edge [m]

w – major road through lane width [m]

VA – visibility angle (Table 4) [°]

x – driver's eye position in vehicle (CP) (Figure 7, Table 2) [m]

Since the minimum allowable intersection angle could not be determined on the basis of the available sight distance, it was also necessary to determine the stopping sight distance so that the available sight distance could be compared to something. To determine the stopping sight distance it was necessary to calculate the path length (s) and time (t), needed for the vehicle to cross one major road traffic-lane. For the calculation of the path length the following formula was used:

$$s = l - y + \frac{o + w}{\sin \alpha} + \frac{b - x}{\operatorname{tg} \alpha} \quad (6)$$

where:

$\alpha$  – intersection angle [°]

b – vehicle width (minor road) (Table 2) [m]

l – vehicle length on the minor road (Table 2) [m]

o – driver's head (eye) distance from the traffic lane edge [m]

s – path [m]

w – major road through lane width [m]

x, y – driver's eye position in vehicle (CP) (Figure 7, Table 2) [m]

The obtained path data (s) were used to calculate the time (t). The calculation was based on the hypothesis that the cars move with constant acceleration starting from the moment when the drivers estimate that the situation on the major road is favorable for performing the necessary traffic action. Therefore, formula (3) was used for time (t) calculation for constant acceleration on the straight line. Input data on the acceleration and the time of reaction are the same as for the calculation of time (t) at intersections with intersection angles bigger than 90° (Section 2.1). Based on the calculated time (t) and available sight distance (ASD) using formula (4) the stopping sight distance (SSD) was calculated for different vehicle speed on the major road (from 20 to 100 km/h).

The data on the available and stopping sight distance for intersection angles of 45 to 90° were used for making nomographs (Figure 8). Based on the criteria of stopping sight distance for the speed of 40 and 80 km/h and the available sight distance for 120° visibility angle by means of nomographs minimum and maximum allowable intersection angles (< 90°) were determined separately for both test vehicles. For both test vehicles the same allowable intersection angles were obtained: for the speed of 40 km/h angle was 55°, and for the speed of 80 km/h angle was 57°.

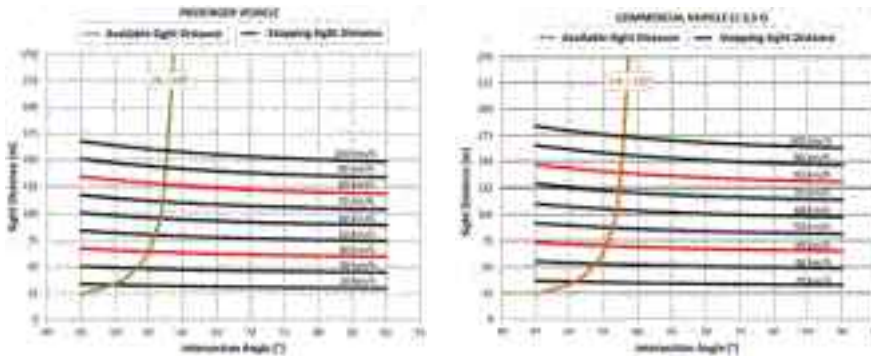

Figure 8 Sight distance nomographs for a passenger car and a van ( $\leq 3.5$  t)

### 3 Conclusion

Sight distance tests carried out on different intersection schemes, respecting the parameters which influence the visibility from the vehicle, resulted in different minimum ( $<90^\circ$ ) and maximum ( $>90^\circ$ ) allowable intersection angles up to which it is possible to keep the minor road axis in the direction (Figures 3, 4, 8, Table 3). Research results shown on nomographs (Figures 3, 4) and in Table 3 demonstrated that for intersection angles bigger than  $90^\circ$  allowable intersection angles differ significantly depending on the position of the driver's head in the vehicle and the type of the vehicle. Due to their performances and dimensions passenger cars allow the application of bigger intersection angles ( $120^\circ$ ) than trucks ( $109$  to  $115^\circ$ ). In the process of testing sight distance and setting allowable intersection angles the least favorable driver's head position was also used which resulted in the smallest visibility angles ( $VA_{SB}$ ) from the vehicle. If allowable intersection angle was determined even for those visibility angles for the speed of  $40$  and  $80$  km/h, in that case intersection angles for  $3$  to  $10^\circ$  (depending on the test vehicle) would be smaller than intersection angles for visibility angles  $VA_{CP}$  and  $VA_{LF}$ . Apart from that, for the smallest visibility angles ( $VA_{SB}$ ) allowable intersection angles had to be limited to less than  $100$  or  $105^\circ$ , but such a restrictive limit was not present in any considered guideline [5, 6] or scientific papers so far [1, 2]. Based on these data it is recommended that the maximum allowable intersection angle should be  $110^\circ$  under the condition that intersections with intersection angles  $\leq 105^\circ$  can be applied when the speed limit on the major roads is  $80$  km/h or less, and intersections with angles between  $105$  and  $110^\circ$  can be applied only when speed limit on the major road is  $40$  km/h. This would completely fulfill the criteria for safe traffic flow at intersections.

For intersection angles smaller than  $90^\circ$  allowable intersection angles are the same for a passenger car and a van. Nomographs for intersection angles smaller than  $90^\circ$  (Figure 8) reveal that even small differences between intersection angles result in big differences in vehicle speed. For example, for the difference of only two degrees (from  $55$  to  $57^\circ$ ) between intersection angles, the speed limit on the major road ranges from  $40$  to  $80$  km/h. Based on these data it is recommended that the minimum intersection angle of crossing roads should be  $55^\circ$  under the condition that intersection angles between  $55$  and  $60^\circ$  are exclusively applied at intersections with  $40$  km/h speed limit on the major road, while the intersections with intersection angles  $> 60^\circ$  can be applied when the major road speed limit is  $80$  km/h or less. That would completely satisfy the criteria of safe intersection traffic flow.

Designers and researchers are left with a possibility to determine by themselves even some other (more or less severe) criteria of determining intersection angles on the basis of given nomographs.

## References

- [1] Gattis, J. L. and Low, S. T. Intersection Angle Geometry and the Driver's Field of View. Transportation Research Record n° 1612, University of Arkansas, USA. Mack-Blackwell National Rural Transportation Study Center, 1997, pp. 10-16.
- [2] Son, Y. et al. Methodology to Calculate Sight Distance Available to Drivers at Skewed Intersections. Transportation Research Record n° 1796, 02-3487, Myong Ji University, Kyunggido, South Korea, Department of Transportation Eng., 2002, pp. 41-47.
- [3] Garcia, A. Lateral Vision Angles and Skewed Intersections Design. Proc., 3rd International Symposium on Highway Geometric Design, Chicago, June 29-July 1, 2005.
- [4] Garcia, A., Belda-Esplugues, E. Lateral Vision Angles in Roadway Geometric Design. Journal of Transportation Engineering, Vol. 133, No. 12, December 2007, pp. 654-662.
- [5] Richtlinien für die Anlage von Strassen Teil: Knotenpunkte, Abschnitt 1: Plangleiche Knotenpunkte, Forschungsgesellschaft für Straßen- und Verkehrswesen (FGSV), Köln 1988.; Beiblatt 2001.
- [6] A Policy on Geometric Design of Highways and Streets 2004. American Association of State Highway and Transportation Officials.
- [7] JATO Dynamics: <http://www.jato.com>
- [8] ACEA - European Automobile Manufacturers' association:
- [9] <http://www.acea.be/index.php/collection/statistics>
- [10] Volkswagen Croatia: <http://www.volkswagen.com.hr/>
- [11] Mercedes-Benz Deutschland - LKW: <http://www.mercedes-benz.de>
- [12] Plangleiche Knoten – Kreuzungen, T-Kreuzungen, Österreichische Forschungsgesellschaft Straße-Schiene-Verkehr (FSV), (RVS 03.05.12), Wien, 2007.
- [13] The Road Traffic Safety Act (NN 67/08).
- [14] Commission Directive 2009/113/EC of 25 August 2009 amending Directive 2006/126/EC of the European Parliament and of the Council on driving licences.
- [15] Book of regulations on medical examinations for drivers and candidate drivers (NN, br. 1/11).
- [16] Isler, R. B., Parsonson, B. S., and Hansson, G. J. 1997. Age-related effects of restricted head movements on the useful field of view of drivers. *Accid. Anal. Prev.*, 29(6), 793–801.





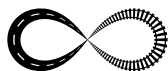

## THE BEHAVIOUR OF PASSIVELY SAFE ROADSIDE COLUMNS IN IMPACT WITH VEHICLES

Višnja Tkalčević Lakušić, Stjepan Lakušić

*University of Zagreb, Faculty of Civil Engineering, Zagreb, Croatia*

### Abstract

Roadside columns are often the point of impact of vehicles with serious and often fatal consequences. To reduce the number and severity of such accidents, a growing number of scientists and experts are trying to find technical solutions for improving behaviour of roadside columns during the collision with a vehicle. It is about columns which can, unlike the usual rigid columns, absorb the energy or break in a controlled way when impacted by a vehicle. These types of columns belong to the category of passive safety road equipment. They are still in the initial stages of implementation in some countries of the European Union. The paper gives a comprehensive overview of passively safe roadside columns with respect to material production and energy absorbing properties and examines the safety level for the passengers in the vehicle. It analyses the behaviour of three types of columns in a collision with a vehicle with respect to the possibility of absorbing a certain amount of energy, failure mode and passenger safety. The analysis has been made based on comparisons of results of the crash tests and numerical simulations of impacts. It describes in detail the advantages and disadvantages of the application of passively safe roadside columns over traditional rigid columns, which are now still usually implemented along the roads.

*Keywords: roadside columns, accidents, passive safety, absorption energy, crash tests*

### 1 Introduction

Road safety is now on the agenda more than ever. Traffic accident consequences are presently a major problem. Only in the Republic of Croatia, in the last 10 years, 663 thousand traffic accidents occurred, out of which 6 thousand accidents were fatal, 42 thousand people were severely injured and 187 thousand people suffered minor injuries [1].

Roadside columns, like lightning columns, traffic signal poles and signposts are very often points of impact of vehicles, with severe and often fatal consequences. According to the statistics, every year in the world, thousands of people die and hundreds of thousands are injured after the vehicle's impact with a roadside column. For example, in Great Britain between 2001 and 2006 (inclusive), 12 361 traffic accident occurred when a vehicle struck a lighting column, and 8 849 traffic accidents occurred when a vehicle struck a signal post or a traffic signal [2]. To reduce the number and severity of traffic accidents caused by impacts of vehicles to roadside objects, the European Commission in the year 2000 suggested the usage of passive safety infrastructure along the roads, especially lighting columns with adequate energy absorbing properties at impact.

For illustration, Figure 1 shows the consequences of a vehicle impact at similar speed but on two different column structures: usual rigid column, which is typical for our roads, and deformable column, which belongs to the passive safe infrastructure.



a) Rigid column [3]



b) Deformable column [4]

**Figure 1** Consequences of the vehicle's impact with different column types

It is known that during the impact of the vehicle with a column a large quantity of energy develops. If the column is the usual rigid one, during the impact it moves slightly and almost all of the energy transfers to the vehicle and its passengers (Figure 1.a). However, implementation of columns that can deform and absorb energy would dramatically reduce energy that the vehicle would have to absorb upon the impact, thus resulting in less aggressive drop in acceleration with respect to time as well as the larger safety of passengers.

The possibility of energy absorption of the column, during vehicle's impact, depends, among other things, on the material out of which the column was created. For example, wooden and concrete columns show little deflection while impacted by a vehicle so the majority of energy created during the impact will be absorbed by the vehicle. However, steel, aluminium and composite columns show higher deflection thus absorbing more energy during impact.

Presently, steel columns are usually implemented along the roads because they are relatively lightweight, cost effective, durable and have an appropriate anticorrosive protection, have good reliable and predictable strength and behavior and can be fully recycled. However, it has been shown that in the case of impact aluminium columns are far less dangerous obstacles than steel ones because they can absorb 50% more energy than steel ones of the same weight, so that the possibility of physical passenger injury is appreciably reduced [5]. Furthermore, aluminium columns are 1/3 lighter than the steel columns, they have a long lifespan, hardly any maintenance costs and can also be fully recycled.

Recently, for the construction of roadside columns fiberglass reinforced polymers (FRP) have been used as the most expensive alternative to traditional materials, but with excellent energy absorbing values at impact. In comparison with steel and aluminium columns, fiberglass columns are low weight and easy installation, higher yield strength and flame resistant. Furthermore, fiberglass columns are maintenance-free because they are extremely resistant to environmental influences, such as water, chemicals and salt and are therefore less sensitive to corrosion.

## 2 Types of passive safe columns

Passive safety roadside columns in the European Union countries are tested and classified in accordance with the European Standard EN 12767:2007 [6]. This Standard specifies performance requirements and defines levels in passive safety terms intended to reduce the severity of injury to the occupants of vehicles impacting with the permanent road equipment support structures. Consideration is also given to other traffic and pedestrians.

According to [6] three categories of passive safety roadside columns are considered:

- high energy absorbing (HE),
- low energy absorbing (LE),
- non-energy absorbing (NE).

Energy absorbing columns slow down the speed of the vehicle considerably and thus the risk of secondary accidents with structures, trees, pedestrians and other road users can be reduced. Non-energy absorbing columns permit the vehicle to continue after the impact with limited reduction of speed.

Furthermore, the Standard contains the rules for executing and interpreting the results of crash tests under different impact conditions and different vehicle speeds. Two crash tests are required, one at 35 km/h, to ensure satisfactory functioning of the support structure at low speed, and a second at one of the 3 speeds 50, 70 or 100 km/h.

In the [6] occupant safety levels in the traffic at the moment of impact are specified, from 1 to 4, with increasing levels of safety reflected by higher numbers. Levels 1, 2 and 3 provide increasing levels of safety in that order by reducing impact severity, while level 4 comprises very safe support structures, meaning small constructions that will cause minor damages to the vehicle upon impact. The Standard also defines roadside columns with no performance requirements for passive safety as class 0.

To declare the occupant safety level, two values are measured in crash tests: AS<sub>I</sub> (Acceleration Severity Index) and THIV (Theoretical Head Impact Velocity). AS<sub>I</sub> is a measurement of the severity of the impact. This is a non-dimensional value of the vehicle acceleration, which the occupant undergoes in the vehicle upon impact. The Standard applies across a range of 1.4 for the lowest safety level to 0.6 for the highest safety level.

THIV value is the speed measure at which occupant's head impact in interior parts, Figure 2. The Standard applies across a range from 44 km/h for the lowest safety level to 11 km/h for the highest safety level.



**Figure 2** Determining the THIV value

Performance type of the columns is determined on basis of vehicle speed upon impact with the column, energy absorption category of column and occupant safety level, as is shown in Table 1.

**Table 1** Performance type of the columns [6]

	Alternatives
Speed class [km/h]	50, 70 or 100
Energy absorption category	HE, LE or NE
Occupant safety level	1, 2, 3 or 4

The officially certified performance is expressed, for example 70 HE 3 where:

70 – means vehicle speed in [km/h] upon impact with the column,

HE – means high energy absorbing column,

3 – means the item has an occupant safety level of 3.

A scheme of the passive safe column classification and the safety level according to [6] is given in the Figure 3.

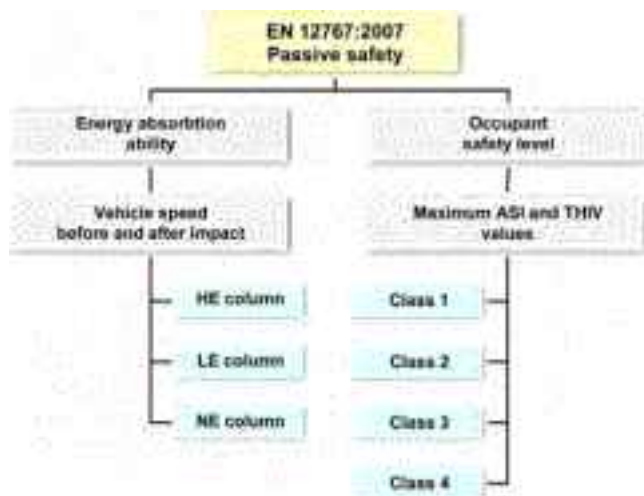

Figure 3 Column classification and safety level according to [6]

### 3 Behaviour of the passive safe columns

#### 3.1 Non-energy absorbing columns (NE columns)

Passive safe columns which do not absorb energy (NE columns) are designed to shear or fail at the base upon impact, after which the column keels over the top of the vehicle and fall on the ground behind it, Figure 4. After the impact, the vehicle continues its movement with a limited reduction in speed and relatively minor damage. In this way, a lower primary risk of passenger injuries is achieved, but higher risk of secondary crashes of the vehicle with trees, pedestrians and other traffic participants exists because of the vehicles continuation of movement and the column fall.



Figure 4 Non-energy absorbing column behaviour [6]

Behaviour of NE columns upon impact of the vehicle in a crash test has been shown in Figure 5. The crash test has been conducted in the leading European centre for vehicle reliability and crash tests research TTAI (TÜV Rheinland TÜO Automotive International) [7]. Crash tests were conducted with a impact speed of 35 km/h and 100 km/h. For the column to satisfy the classification for the speed of 100 km/h in accordance to [6], it was necessary that the vehicle had an exit speed of minimal 70km/h, which is measured at 12 m beyond the impact point. In this test the measured exit speed was 84.8 km/h, so it was higher than the threshold. The ASI and THIV values were in accepted value.



Figure 5 Crash test with a non-energy absorbing column [7]

After the column hits the ground (from the vehicle impact with the column until falling down of the column approximately 1.5 sec passes), the column wrinkled on different locations, but there was no breakage on or next to the welds. After the impact, all the column parts fell behind the vehicle, there were no deformations on the roof of the vehicle and the windshield was undamaged, Figure 6. It can be seen that upon vehicles impact with such a column the occupant injuries would be considerably smaller than in the case of an impact with a regular rigid column.



Figure 6 Column detail and vehicle after the crash test [7]

### 3.2 High energy absorbing columns (HE columns)

During the impact, a high energy absorbing column (HE columns) flattens and rolls under a vehicle, thus absorbing energy, Figure 7.



Figure 7 High energy absorbing column behaviour [6]

Such columns considerably slow down and stop the vehicle upon impact. Because of this the risk of secondary collisions of the vehicle with objects along the road, trees, pedestrians and other road users is reduced, however the severity of the impact for vehicle occupants can be high.

Behaviour of high energy absorbing columns upon impact of the vehicle will be shown on the example of composite lightning columns testing [8]. In crash tests, conducted in accordance with EN 12767 in Finland, 10, 12.4 and 15 m high columns were tested with the vehicle speed of 35 km/h and 100 km/h at the point of impact. Crash tests were conducted with the Peugeot 205.

After the conducted crash tests the Russian laboratory Computational Mechanics Laboratory (CompMechLab) performed crush tests numeric simulations with the finite elements method (FEM) for some lightning column types at different vehicle speed. Lightning poles of different heights were analyzed, with different inner and outer diameters and different quantities of reinforcement in the composite material structure. For conducting a nonlinear dynamic analysis upon impact of the vehicle with the column, a LS-DYNA computer programme was used. 3-D FE models of columns and vehicles were created, Figure 8. In the analysis some nonlinearities were taken into account such as the dynamical impact on different vehicle speeds, plasticity in columns and parts of vehicles, contact interaction between simulated vehicle and the column and the progressive damages in the column material.



Figure 8 3-D FE model of vehicle and column [8]

Figure 9. illustrates a FE simulation of the composite column behaviour and the vehicle at the speed of 100 km/h upon impact. It can be seen that during the crash test the column went through a plastic deformation and after that sliding under vehicle.

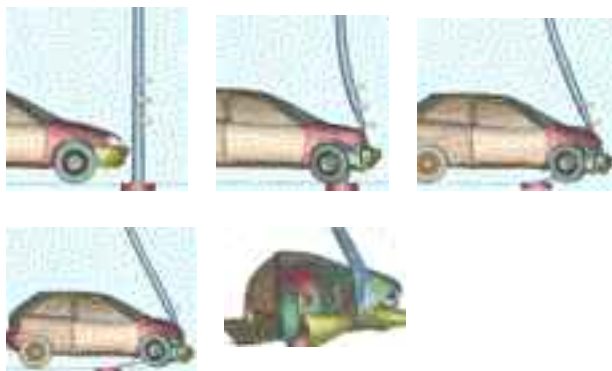

Figure 9 The FE simulation of the crash test of HE column [8]

Figure 10. shows a comparison between the real crash test and the FE simulation of the vehicle and column after impact. It can be seen that the damage on the vehicle upon the impact with that type of column is smaller, and the occupant safety greater than in the case of the crash with a usual rigid column.



Figure 10 Vehicle after impact [8]

### 3.3 Low energy absorbing columns (LE columns)

Columns that can absorb low levels of energy (LE columns) are a good combination of energy absorption and passenger safety because they have some of the qualities of both HE and NE columns. They are designed to yield in front of and under the impacting vehicle, before shearing or detaching towards the end of the impact event. The behaviour of such columns is shown in Figure 11.



Figure 11 Low energy absorbing columns behaviour [6]

The vehicle speed will be reduced and the damage will be smaller than if it had hit an high energy absorbing column. Because of the before mentioned reasons, LE columns are convenient for implementation on standard roads. In Figure 12 and Figure 13 crash tests of vehicles with steel columns from the 100 LE 3 class are shown. The tests were conducted at vehicle speed of 35 km/h and 100 km/h.



a) Column and the vehicle after the crash



b) Column after impact - the column stopped the vehicle

Figure 12 Crash test at speed of 35 km/h [9]





a) The vehicle and the column before crash test



b) The column after the impact – vehicle speed was reduced to 60 km/h

**Figure 13** Crash test at speed of 100 km/h [9]

## 4 Advantages and disadvantages of passive safe columns

The advantages of the passively safe roadside column over traditional rigid columns are: a lower risk of severe injuries to vehicle occupants, easier replacement if hit by vehicle and do not require a safety barrier. With the implementation of NE columns the highest passenger safety is achieved because after the impact the vehicle continues its movement but with decreased speed and minimum damage on the vehicle in relation to other column types. Thus, NE columns can be the most appropriate choice on non-built up roads with insignificant volumes of non-motorised users.

LE and HE columns considerably slow down the vehicle and reduced the risk of secondary collisions of the vehicle with pedestrians, cyclists and other traffic participants. That's why they have the advantage on built-up roads where there is a significant volume of non-motorized users.

The application of passive safe columns is suggested on rural roads, especially where it is difficult to use safety barrier, or where the safety barrier itself could cause a traffic accident, for example on a roundabout splitter island. They are less necessary where there is an existing barrier, or where there is a building or rocks exist close to the road.

As it is mentioned, when crashing into a usual rigid column there is a high risk for the passengers in the vehicle, and the risk is minor for other road users. However, on point of impact with a passive safe column, the risk is smaller for the passengers in the vehicle but there is also a small chance of a secondary accident because of the column falling to the side walk and this presents a potential risk for other drivers and pedestrians in the vicinity. The risk for pedestrians is much greater in urban than in rural areas. The risk depends on the number of pedestrians and exposed columns and therefore the recommendations of the [6] is that the passively safe columns are not appropriate on places where a large number of pedestrians on a regular basis is expected. In these cases, pedestrian safety might need to be considered separately as the risk of an errant vehicle is greater than that from a falling column or signposts.

## 5 European Commission guidelines regarding the roadside columns

In accordance with the European Commission guidelines [4] columns on new roads should be located beyond the safety zone. If this is not possible, only passively safe columns should be used. All columns should be tested according to the Standard EN 12767:2007.

In the EU countries until recently highway columns should have been placed behind safety barriers. With the law change, it has been allowed that along the highways columns without safety barriers be placed but under the condition that they are tested and certified in accordance with the [6]. It is decided that without safety barriers, along the highways, safety class 100 NE 3 columns can be placed. These columns do not absorb energy and secure the maximum safety for the passengers in the vehicle that crashed into a column.

Passive safe columns should be used on main roads where the probability of their fall on the board walk is small or where a small number of pedestrians is expected in the vicinity. National Annex for BS EN 12767 [11] for rural roads recommends the usage of non energy absorbing columns 100 NE unless there is a significant number of pedestrians or cyclists expected because of the risk of a falling column. In urban areas the usage of 70 LE or HE lightning columns is recommended and 70 LE signposts.

Old rigid steel, concrete or wooden lightning column can be replaced with energy absorbing or breakaway column. These columns can be made out of steel, aluminum, wood or composite materials and are recommended in places where pedestrian lanes aren't that close to the columns. Existing wooden or steel columns can be modified into ones which can break when during impacted by a vehicle. Figure 14 shows possible modifications of a rigid column.



Figure 14 Examples of the break-away NE columns [4]

## 6 Conclusion

Traffic accidents will always be present, but they can be reduced, the number as well as the consequences. One of the ways for reducing the severity of accidents is the usage of passive safe equipment along the roads, specifically passive safe columns. The European Commission recommendation with the goal of decreasing the number and the severity of traffic accidents is the usage of these types of columns along the roads. Although, with the usage of columns that can brak-away or absorb energy in a controlled way, the safety of drivers is increased, but the risk for pedestrians and other road users increases as well because of the possibility of a falling column. Because of this, during the designing of the roadside equipment, especially new columns, new materials and column failure modes must be considered. With this approach the severity of injuries of passengers in the vehicle upon impact will be reduced and higher safety will be achieved for other road users, especially for pedestrians. For the traffic safety to be brought to a higher level, the society should constantly put an effort in the road improvement. The cost of investing in safety increment is surely smaller than the damages that traffic accident cause.

## References

- [1] Bilten o sigurnosti cestovnog prometa-2010., Ministarstvo unutarnjih poslova Republike Hrvatske, Zagreb, 2011.
- [2] Williams, G.L., Kennedy, J.V., Carroll, J.A., Beesley, R.: The use of passively safe signposts and lighting columns, Published Project Report PPR 342, Transport Research Laboratory, 2008.
- [3] <http://autoklub.jutarnji.hr>
- [4] Riser, Roadside Infrastructure for Safer European Roads, Do6: European Best Practice for Roadside Design: Guidelines for Roadside Infrastructure on New and Existing Roads, 2005.
- [5] Allround lighting columns, Nedal Aluminium, Nizozemska ([www.nedal.com](http://www.nedal.com))
- [6] European Committee for Standardization: EN 12767:2007 Passive safety of support structures for road equipment - Requirements and test methods.
- [7] Steel columns, Passive safety steel columns up to 15 meter, PMF, October 2010. ([www.steelpoles.eu](http://www.steelpoles.eu))
- [8] Borovkov, A., Klyavin, O., Michailov, A., Kempainen, M. & Kajatsalo, M.: Finite Element Modeling and Analysis of Crash Safe Composite Lighting Columns, Contact-Impact Problem, 9th International LS-DYNA Users Conference, 2008., pp. 14-11 do 14-20
- [9] Passively Safe Products (<http://www.fabrikat.co.uk>)
- [10] Zippole (<http://www.safety-product.eu/Zippole/>)
- [11] BSI (British Standards Institution, 2007), BS EN 12767:2007 National Annex NA, BSI

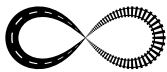

## ACCIDENTS AT THE LEVEL CROSSINGS IN LITHUANIAN RAILWAYS

Inesa Gailienė, Vaidas Ramūnas, Kęstutis Skerys  
*Vilnius Gediminas technical university, Lithuania*

### Abstract

It was discovered that in Lithuania the traffic safety indicators of railway level crossings rank among the worst in Europe, and Lithuania's indicator of the risk for the users of level crossings is twice higher than in most European countries. 178 events have occurred in the Lithuanian railway level crossings during the last ten years. 72 people were killed and 57 people were seriously injured in these accidents. This article analyzes disadvantages of the largest projects that are related to traffic safety improvements at level crossings. It also analyzes the traffic safety situation in the Lithuanian railway level crossings and considers instruments which increase the traffic safety and efficiency. This article presents the study that has examined the condition of 15 level crossings, and introduces the results and conclusions.

*Keywords: accident, level crossings, public education, traffic safety.*

### 1 Introduction

Undoubtedly the most effective way to ensure the safety at the intersections is to close the level crossings. However, level crossings do exist, and closing them is not an easy task. First of all, their number is large, and the costs of closing them are very high considering that two-level intersections should be constructed in their place. Therefore, the issue remains permanently relevant. Because of fast-growing road traffic intensity in Lithuania and the objective to increase the speed of trains it becomes ever more difficult to intersect two traffic infrastructures. Therefore a number of models have been developed to assess the safety at level crossings, which calculates the expected annual number of accidents at a crossing on the basis of the number of crossing variables (Gitelman et al. 2006). However, in the countries where a speedy progress occurs, it is because there is a national and funded programme backed by political will to effect change (Australia, USA, Spain, Portugal) (Nelson 2009). After the country joined the EU, the Lithuanian Railways have carried out some large-scale projects in the railway infrastructure modernization and improvement of the technical conditions. But the problems of level crossings are not being considered in principle, and therefore traffic safety conditions at the level crossings remain largely unchanged. The aims of this article are as follows: to analyze the statistics of traffic accidents and trends in the Lithuanian railway level crossings; to examine what has been carried out in Lithuanian railways to improve traffic safety; to discuss several important projects which dealt with the issue of traffic safety at level crossings and their main problems. Furthermore, the article presents the results of a study, which together with the overview of literature and problems allowed formulating conclusions and recommendations.

## 2 The traffic safety situation in the Lithuanian railway level crossings

At present JSC 'Lithuanian Railways' owns 523 railway level crossings of which 384 ones are controllable, and 139 are not controllable. 48 out of 523 level crossings are onlooked and 475 not onlooked. The number of casualties at level crossings makes up 20% of total rail accident casualties. (Gailienė et al. 2011). A comparison of the distances (in kilometers) between railway level crossings with the other 24 EU countries and Norway showed that in Lithuania there is a level crossing in every 4.17 kilometer of the railway track. The highest density of railway level crossings is in Norway – every 1.02 km, and lowest in Latvia – every 7.38 km. However, although the density of level crossings seems to be not a big problem in the Lithuanian railways, the level of traffic safety at level crossings in Lithuania ranks among the poorest among the countries concerned.

Figure 1 shows the change in the amounts of accidents, fatally injured and wounded people in 2004–2010, and Figure 2 shows how Lithuania looks in the context of other countries according to these indicators. Considering Figures 2 and 3, it may be concluded that although the numbers in absolute values are not high, but comparing the situation in Lithuania and in other countries it is obvious that there is a need to investigate and determine what measures would improve the traffic safety, and effective measures and their correct use are in order. In Lithuania, unlike in the UK for example, all traffic accidents occur due to road irregularities. The UK declares that 63% of the accidents are the results of driving mistakes, 21% of non-compliance with road traffic regulations, 16% of car breakdowns, weather conditions, mistakes of the locomotive driver or duty operators of level crossings, signaling malfunctions of level crossings (M. Knutton, 2004). However, Evans observes that railway operators tend to have a poor view of road users behavior at level crossings, and this is backed up by some well-known video footage of very dangerous behavior of the road users. Nevertheless, it is not clear whether road user behavior is worse on level crossings than on the roads generally (Evans, 2011).

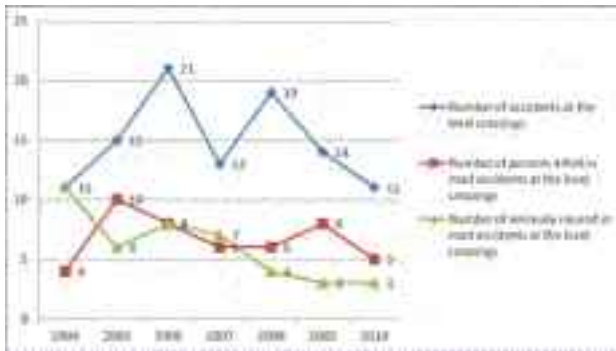

Figure 1 Safety indicators in level crossings of Lithuania in 2004–2010

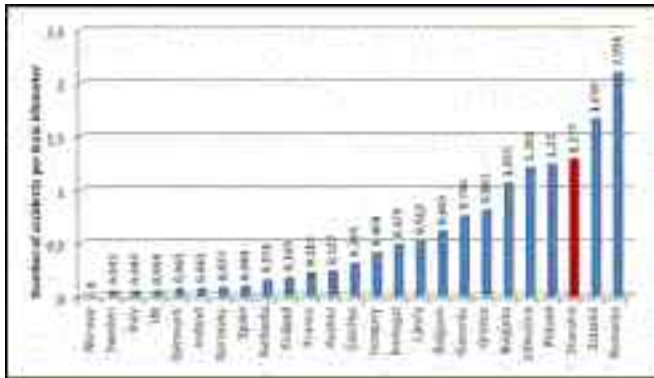

Figure 2 Number of accidents in relation to annual distance of the trains (in millions of km)

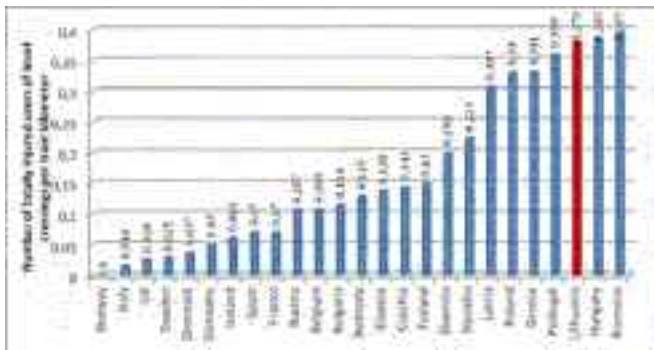

Figure 3 Number of fatally injured users of level crossings in relation to annual distance of the trains (in millions of km)

### 3 The measures improving traffic safety at level crossings and their implementation

The issue of traffic safety in level crossings is discussed and analyzed very often. It is examined on several levels: social, technical, economical, etc. Level crossing safety professionals argue that safety is improved by actions characterized as the three E's: engineering, education and enforcement. The strong effects of engineering solutions such as installing active warning devices and improving the visibility of trains are evident and substantiated in literature. Quantifying and evaluating enforcement activities, such as placing police officers at crossings to issue citations, or installing camera enforcement, is more difficult and has engendered a much smaller pool of literature (Savage 2006). However, engineering solutions alone will not remove the risk arising at level crossings, therefore an equal emphasis on education of users and the taking of punitive action against those who abuse level crossings is necessary (Nelson, 2009). Educational activities have a measurable effect on modifying driver behavior and improving safety (Savage 2006; Koppel 2009; Mok and Savage 2005). A good example is Operation Lifesaver – international organization continuing a public education program first established in 1972 (State Idaho, USA). This operation spread across the USA during the late 1970's and early 1980's when the level of risk was very high. Ian Savage estimates that the initial implementation of Operation Lifesaver prevented 1,455 annual incidents and 164

annual fatalities. Operation Lifesaver is primarily a volunteer organization and operates on a shoestring budget (Mok and Savage 2005). Today the organization has branches in Canada, Mexico, UK, Argentina. The first OLE subsidiary in Europe called Operation Lifesaver Estonia (OLE) was founded in 2004 by Estonian railways and two private persons. In 2007 Operation Lifesaver Europe was founded (Koppel 2009). And currently the United States have a decreasing number of accidents at level crossings (2009 in comparison to 2008 – 14.2%) due to education, implementation of new road traffic rules and dealing with the issues of closing the level crossings (A.Cotey, 2009).

Otherwise, the measures applicable to improving traffic safety at level crossings can be divided to: the essential technical (closing of level crossings and the construction of two-level intersections considering the changes in traffic conditions), maintenance technical (affording visibility, installation of cameras, road markings), socio-educational (drivers' education, increasing the fines, public education). The essential technical tools will be further reviewed in the next section. Maintenance measures are improving the visibility (in Lithuania about half of all level crossings do not comply to the visibility requirements), installation of video cameras, modernization of turnstiles, installation of various measures to draw the driver's attention (installation of more and brighter road signs, speed reduction belts). In Lithuania these issues are poorly dealt with, although different studies easily demonstrate the importance of these measures. Social-educational measures are education of people, wider education, courses, explanations, enforcing and increasing administrative penalties. These measures are particularly needed in Lithuania and not only at level crossings. In Lithuania an attitude that crossing the railway line is possible where it is needed and at any given moment for a particular person is widespread. People still do not understand and are very surprised to learn that walking by rail or crossing it is forbidden for outsiders, they are punished, but do not consider that an offence. Public education in Lithuania has been launched but still remains limited and without any substantial results.

#### 4 Improving traffic safety in Lithuanian railways

'The safety of railway transport and environmental protection' is one of the main areas of the European Union structural assistance in the transport, communications and developing of informational society in 2014–2020. One of this priority's objectives is the implementation of railway transport traffic safety measures by closing single-level railway crossings, fencing the railway network with security fences and so on. At the moment it is difficult to say how this will be carried out. Presently the largest train speed in Lithuanian railway lines is 120 km/h. The existing norms allow the level crossings to be operated where the speed limit is up to 160 km/h. As mentioned, an ongoing project is being carried out on the railway line Vilnius–Kauņas in order to upgrade the speed to 160 km/h. This project is implemented in four phases: designing, modernization of the railway, construction of the second railway line, modernization of the signaling systems. However, the implementation of this project inevitably raises the question of liquidation of level crossings. Whereas at the time the solution of this issue is not possible economically and in point of time, the decision has been made to examine intersections between transport nodes in separate local projects, without connecting them to the current project. Elimination of level crossings has to be solved comprehensively, because this concerns not only the railway infrastructure, but also the municipality's master plans and Road Administration's development plans. Therefore, the projects require a totally different coordination, bringing together several institutions, and a new funding system. Therefore, in accordance with the normative requirements it has been resolved after the modernization of the Vilnius–Kauņas railway line for the speed limit of 160 km/h to maintain the operational speed at railway level crossings limited to 120 km/h until the decision on the issues of installation of two-level intersections will be made. However, the question is, when this will be done.

The largest project implemented by JSC 'Lithuanian Railways' was 'Assuring traffic safety by reconstructing level crossings' (2008). The original plan was to reconstruct 50 level crossings in different territories of Lithuania, however only 36 out of them have been reconstructed because of lack of funds. In the reconstructed level crossings car speed has increased from 10/30 km/h to 50/90 km/h (in town/in outskirts). Following the Requirements for maintenance of level crossings 10 m of road in both sides of the level crossing has been reconstructed as well as the flooring and upper railroad construction of the level crossing. During the project it has been observed that typical technical requirements have been prepared for all the crossings. These requirements include replacement of the upper rail road construction with new one in the level crossing and 25 m in the approach to the crossing. Replacement of the flooring, asphalt works of the road in 10 meters distance to both sides of the crossing, water outlet from the flooring, installation of abutments, renewal or installation of new traffic signs were planned as well. While implementing the project it has not been considered that in some of the level crossings longitudinal inclination of the road does not meet the requirements. This causes poor visibility and driving conditions. In some level crossings intersection angle of railway and road does not meet the requirements of installation of the level crossings, however this issue has not been considered during the reconstruction. This problem has not been solved because of long bureaucracy procedures concerning earth, road rearrangement and similar issues. Reconstruction of intersection angle has not been performed because of lack of funds and time as well. Traffic intensity has not been considered when replacing asphalt. Typical asphalt layer construction has been designed. Taking this project as an example it can be concluded that it is necessary to analyze each level crossing thoroughly evaluating more criterions to estimate the extent of reconstruction and plan for the budget and time necessary for reconstruction before preparing technical requirements (Gailiene et al, 2011).

## **5 Analysis of traffic safety of selected road sections before and after the railway level crossing**

The objective of the analysis is to carry out the inspection of selected road sections before (after) the railway level crossings, to evaluate how the elements of the road correspond to the legislations, to determine the existing shortcomings. The task is to analyze the information about road section (maps, drawings, etc.); traffic in the road section (car traffic volumes, traffic composition, operating speed, etc.); railway level crossing (category, permissible train speed, train traffic volumes, signaling systems of the level crossings, etc.); weaknesses at the road section (vertical and horizontal road markings, road surface, visibility, etc.); weaknesses at the railway section (floorings of the level crossings, signaling systems, drainage gutters, etc.); other weaknesses.

15 level crossings that intersect with state roads were selected for the analysis. The analysis of the level crossings was carried out by a targeted survey. It started with analysis of drawings, photographs, descriptions of traffic accidents and other available materials. After the inspections, it was discovered that there are 85 irregularities at the inspected level crossings. Figure 4 shows the percentage distribution of the detected irregularities at road sections.





**Figure 4** Percentage distribution of the detected irregularities at road sections

It is obvious that almost half of the irregularities (47%) are deficiencies of the vertical marking of the road section. These deficiencies have a significant impact on the organization of safe traffic and they are usually quickly and easily removed.

19% are the deficiencies of level crossing infrastructure. These problems also have a significant impact on the organization of safe traffic but solving them is more complicated than solving marking problems. Some level crossings need minor repairs of floorings and drainage gutters, and others need greater repairs of these elements. 16% consists of visibility problems at level crossings. After the inspection, it was found that only one level crossing fulfilled the conditions of visibility requirements. Provided that Lithuania has a lot of undisciplined drivers who constantly break traffic rules, it is proposed to install speed humps before level crossings as an additional tool to improve road safety.

Analysis showed that in the majority of level crossings road and railway intersect in less than a 90° angle, in part of level crossings the oblique angle of intersections does not satisfy the requirements (minimal oblique angle of road and railway intersection is 60°).

Research results, as expected, have shown that the categories of level crossings do not match actual traffic conditions. This happens because the automobile and train traffic volumes are increasing. The categories of five level crossings should be changed to higher because transport (trains and automobiles) traffic volumes in those crossings are higher than permitted in relevant categories. Category IV should be changed to category III at three level crossings. Such change of level crossing categories does not mean much, because there is no need to improve infrastructure of the level crossings.

One more level crossing should have the category changed from IV to I, and the other – from III to I. As the level crossing of category I should be watched, such level crossing category change requires substantial changes in the infrastructure of the level crossing. Installation of watched level crossing requires substantial investments not only because of changes in the infrastructure, but also because of creating the workplace for the crossing duty operator.

## 6 Conclusions

After the analysis, it has been discovered that the traffic safety conditions at level crossings of Lithuanian railway lines are bad and worse than in most countries of the European Union. This is due to the lack of attention paid to engineering, enforcement and education measures. However, the large-scale reconstruction and modernization projects concerning the issues of improving traffic safety at level crossings are dealt with superficially or the solutions are postponed.

The inspections on traffic safety of road sections before (after) railway level crossing were carried out. During these inspections 85 irregularities were identified in road sections. Deficiencies were mainly found in the vertical marking of road section, and they accounted for 47% of the irregularities. Weaknesses were also identified in the installations of level crossing infrastructure, pavement, visibility and other. It was settled that categories of five level crossings should be higher than they are currently accredited.

In order to ensure traffic safety at level crossings, where the lack of visibility was found out, humps can be installed before railway level crossings to reduce the speed. The installation of speed humps would reduce the number of drivers who do not stop before a railway crossing. In order to identify the effectiveness of engineering measures, investigations on the efficiency of humps (to reduce the speed) are proposed.

## References

- [1] AB 'Lietuvos geležinkeliai' valdomų geležinkelių pervažų eismo saugos analizė. 2010 01 18. Valstybinė geležinkelio inspekcija prie Susisiekimo ministerijos [Analysis Of Traffic Safety At The Level Crossings Operated By Sc 'Lithuanian Railways'. 2010 01 18. State Railway Inspectorate Under The Ministry Of Transportation] [www.vgi.lt]
- [2] Gailiene, I.; Gedaminskas, M.; Podagelis, I. 2011. The main problems concerning safety, maintenance and reconstruction of level crossings in Lithuanian railway lines. in The 8th International Conference 'Environmental Engineering': Selected paper (19–20 May 2011, Vilnius, Lithuania) 3: 1077–1081. ISBN 978-9955-28-829-9.
- [3] ERADIS-European Railway Agency Database of Interoperability and Safety. Available on the Internet: [http://pdb.era.europa.eu/safety\\_docs/csi/default.aspx](http://pdb.era.europa.eu/safety_docs/csi/default.aspx).
- [4] Gitelman, V.; Shalom Hakkert, A.; Doveh, E.; Cohen, A. 2006. Screening Tools for Considering Garde Separation at Rail-Highway Crossing. *Journal of Transportation Engineering*, 132(1): 52-59.
- [5] Įskaitinių eismo įvykių statistika Lietuvoje. 2007-2010 m. [The Statistics of Recorded Traffic Accidents in Lithuania, 2007-2010. Lithuanian Road Administration Under The Ministry Of Transportation]. 2011
- [6] Knutton, M. 2004. Interim measures will reduce: a report published in January provides detailed accident analysis and recommendations for improving road vehicle level crossings in Britain. *International Railway Journal*, 4: 24-26.
- [7] Koppel, O. 2009. Traffic Safety Management at Single-Level Road – Railway Crossings: Estonian Experience. In The 29th International Baltic Road Conference. Available in the Internet: <[https://www.balticroads.org/conference27/index\\_](https://www.balticroads.org/conference27/index_)
- [8] McCollister, G. M.; Pflaum, A. 2007. A model to predict the probability of highway rail crossing accident. In Proc. of the Institution of Mechanical Engineering. Part F – Journal of Rail and Rapid Transit, 221(3): 321-329.
- [9] Mok, S.C.; Savage, I. 2005. Why Has Safety improved at Rail-Higway Garde Crossings? *Risk Analysis*. 25(4): 867-881.
- [10] Nelson, A. 2009. Level crossing: How safe can they be? In The 29th International Railway Safety Conference. Available on the Internet: <<http://www.intrailsafety.com/index.html>>.
- [11] Savage, I. 2006. Does public education improve rail-highway crossing safety? *Accident Analysis and Prevention*, 38(2): 310-316.
- [12] A.Cotey. *Progressive Railroadng*, 2009. No 1, p.32-41. <http://www.fra.dot.gov>
- [13] Evans. E. 2011. Fatal accidents at railway level crossings in Great Britain 1946-2009. *Accident Analysis and Prevention* 43(5), 1837-1845.
- [14] Kelių saugumo patikrinimo tvarkos aprašas. Automobilių kelių direkcija prie Susisiekimo ministerijos [The Description Of Procedures For Inspection On Road Safety. Lithuanian Road Administration Under The Ministry Of Transportation]. Vilnius, 2010. 7 p.
- [15] Pervažų įrengimo ir naudojimo taisyklės [Regulations For Installing And Using The Level Crossings]. Vilnius, 2005. 36 p.
- [16] Vidutinis metinis paros eismo intensyvumas valstybinės reikšmės keliuose Lietuvoje, 2006–2010 m. vĮ Transporto ir kelių tyrimo institutas [The Average Annual Daily Traffic Intensity Roads Of National Significance Of Lithuania, 2006–2010. A State Enterprise Of Transport And Road Research Institute]. 2011.



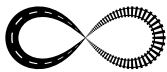

## ANTI-SLIP RUBBER BASE FOR PEDESTRIAN CROSSINGS

Marko Hoić<sup>1</sup>, Igor Keser<sup>2</sup>

<sup>1</sup> HŽ-Infrastruktura d.o.o., Croatia

<sup>2</sup> Elasto d.o.o., Croatia

### Abstract

On the HŽ-Infrastructure network there are 242 stations, 338 train stops, or a total of over 600 pedestrian communications for the movement of passengers and railway staff. If we add this 71 pedestrian crossing on the open line – we get the total number of spaces for movement and pedestrians crossing the tracks.

The footpath in the track is mainly performed as a wooden construction of railway sleepers. Such a surface is already slippery from the impregnation of sleepers, but under the influence of rain, snow and ice also very dangerous for pedestrians.

In order to ensure the safe movement of pedestrians across the track and extend the lifespan of wooden construction of railway sleepers – in this paper is proposed simple and inexpensive solution of 'rubbed' of new or already used pedestrian communications with a special rubber elements attached to the upper surface of the wooden structure.

*Keywords: pedestrian cross-communications, railway track, anti-slip modular elements, rubberized*

### 1 Introduction

Places for movement pedestrian over the railway track in the same level are called pedestrian crossings. In the railway station those are pedestrian cross-communications for the movement of passengers and railway staff. They connect station building with the railway tracks and platforms for the reception of travelers, so they are equally in use from railway workers and passengers. On the open line there are singly pedestrian crossings, or connected with a railway-crossing.

The footpath in the track is mainly performed as a wooden construction of railway sleepers. Such a surface is already slippery from the impregnation of sleepers, but under the influence of rain, snow and ice also very dangerous for pedestrians. Since the movement of pedestrians on the station tracks is only possible over such wooden structures it is inevitably that a lot of falls with mild or severe injuries of railway staff and passengers happens in railway traffic. Therefore it is necessary to upgrade an existing solution so the movement of pedestrians across the track is safer, and the wooden construction more durable.

### 2 Improvement proposal

On the HŽ-Infrastructure network there are 242 stations, 338 train stops and 71 pedestrian crossings on the open line. Because several of them are in every station, in total there are over 1000 pedestrian communications for the movement of passengers and railway staff. Almost all were made as wooden construction of railway sleepers.

Current legislation in this area is very poor. 'HŽ-Rulebook for permanent way track maintenance' (Rulebook 314, article 26. paragraph 2.) referred only to wooden construction of railway

sleepers with the prescribed statutory breadth and depth of groove for passage of railway vehicle wheel rim.

In order to ensure the safe movement of pedestrians across the track and extend the lifespan of wooden construction of railway sleepers – in this paper is proposed solution of 'rubberized' of new or used pedestrian communications with a special modular rubber elements attached to the upper surface of the wooden structure.

### 3 Technical solution of improvement

As a technical solution 'rubberized' the existing wooden construction it is proposed creating modular rubber–metal anti–slip elements that are tightened with screws to the existing structure. So fixed they are a compact solution to the problem of extremely slippery trampling surfaces of pedestrian communications.

In geometric terms anti–slip modular elements on its upper surface are striated in a manner that provides increased adhesion tread surface. Area between the grooves is covered with micro–roughness which further increases the friction of tread surface. Hardness of the rubber body is chosen in the range 55–65 ShA (Shore A), which enhances the feeling when using 'rubberized' pedestrian cross–communication.



Figure 1 Anti–slip element

Single anti–slip modular element is very small (26×26 cm) what we consider the advantage of the larger elements, since in case of mechanical or other damage, one can be replaced very easily and without major cost.

During manufacturing (vulcanization) of elements in their body are built–in four steel rings for receiving bolts for attach to the substrate, which creates a virtually unbreakable bond between the metal inserts and rubber body of anti–slip element, which results in extremely high durability. Additionally, steel rings are galvanized which leads to high resistance to corrosion. Rubber body of elements should be made of Chloroprene rubber due to its extremely compliant properties.

#### 3.1 CR – Chloroprene rubber – features and benefits

Among the large number of specialized elastomers – CR chloroprene rubber occupies an important place in world rubber consumption with the annual needs of around 300,000 t worldwide. CR was first produced 1932nd in DuPont company (responsible for the invention of Kevlar), and since then CR, widely known as Neoprene®, thanks to combination of very good technical characteristics, ranks high in world practice.

CR by its characteristics does not belong at the top among elastomers because CR is not characterized by one outstanding property, but its balance combination of properties is unique among the synthetic elastomers. It has:

- Good mechanical strength
- High ozone and weather resistance
- Good aging resistance
- Low combustibility (one of the rare elastomers with self-extinguishing properties)
- Good resistance toward chemicals
- Moderate oil and fuel resistance
- Excellent adhesion to metals

Because of all these positive characteristics we believe that the chloroprene is ideal choice for use in making anti-slip trampling surfaces of pedestrian communications.

## **4 Installation of modular anti-slip elements**

Installation of modular anti-slip elements is essentially a very simple process that requires no highly skilled labor nor sophisticated or expensive machinery and equipment.

Installation consists of the following five stages:

- Preparation of the existing wooden construction
- Tentative laying of anti-slip elements
- Marking the position of the fixing screws
- Drilling screws holes in the wooden base
- Finally screws fixing

### **4.1 Preparation of the existing wooden construction**

Surface preparation consists mainly from visual inspection of the existing wooden structure, followed by removal any of foreign matter that could interfere with installation. If visual inspection determines that certain elements of wooden structures are so dilapidated that they are not suitable for screw fixing of anti-slip elements, such parts must be replaced with the new or appropriate wooden structure.

### **4.2 Tentative laying of anti-slip elements**

The objective of this phase is to determine the final layout of all elements, to avoid the possibility of overlapping the position of screws for fixing elements with the position of the screw for fixing wooden surface to the railway sleepers. During this phase it is necessary to slightly move anti-slip elements in the direction of the axis of the track until they come to a suitable position.

### **4.3 Marking the position of the fixing screws**

Marking the position of the screws to attach anti-slip elements performed using simple handy tool, and aims to precise positioning of future holes for mounting screws in order schedule anti-slip elements remain exactly as defined in the previous phase.

### **4.4 Drilling screws holes in the wooden base**

Drilling holes appropriate diameter and depth is performed with drill for wood using simple hand-held electric drill. During this operation is necessary to pay attention to the perpendicular of holes in relation to the upper surface of the wooden structure. Allowed a deviation

is up to 10° because construction of the fastening place of anti-slip elements is such to compensate this discrepancy.

#### 4.5 Finally screws fixing

The purpose of this operation is finalizing of installation anti-slip modular elements. For this operation also uses standard electric power drill which is equipped with an adequate key for hexagon head bolts.

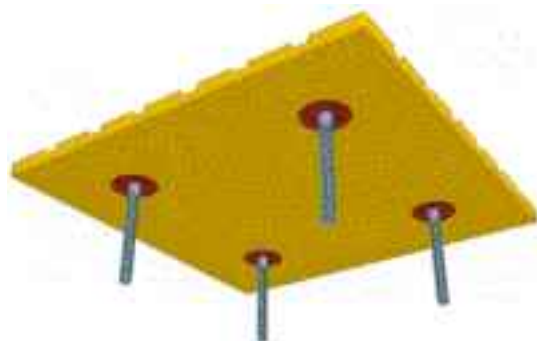

Figure 2 Anti-slip element fixation

## 5 Conclusion

In order to ensure the safe movement of pedestrians across the track, avoid falls with mild or severe injuries, and extend the lifespan of wooden construction of railway sleepers – in this paper is proposed solution of 'rubberized' of new or used pedestrian communications with a special modular rubber elements attached to the upper surface of the wooden structure. Based on the above we consider that an acceptable solution is described primarily as an efficient, simple, fast and relatively inexpensive way of solving problems of extreme slippery pedestrian cross-communications made of wood.

Although today there are other solutions to this problem, in conditions of global recession and stagnation of investment, we believe that the proposed solution could be bridge between the current situation and the future, which certainly belongs to comprehensive, sophisticated and demanding financial-technical solutions.

## References

- [1] Esveld, C.: Modern Railway Track, Second edition, TU-Delft, 2001.
- [2] Schwager, T. & Poschel, T.: Rigid Body Dynamics of Railway Ballast (Chapter), System Dynamics and Long-Term Behaviour of Railway Vehicles, Track and Subgrade, eds. K. Popp & W. Schiehlen, Springer-Verlag, Berlin and New York, pp.451-470, 2002.
- [3] Branka Andričić: Polimerni materijali, Kemijsko-tehnološki fakultet Split 2010.
- [4] HŽ – Rulebook for permanent way track maintenance (Rulebook 314)

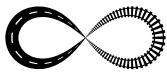

## A MODEL FOR ASSESSING COLLISION RISK ON AUTOMATIC LEVEL CROSSINGS

Mohamed Ghazel<sup>1,2</sup>

*1 Univ Lille Nord de France, Lille F-59000, France*

*2 IFSTTAR, ESTAS, Villeneuve d'Ascq F-59650, France*

### Abstract

Railway engineers always point out Level Crossings (LC) as a one of the most critical points in railway networks from the safety point of view. Statistics show that more than 300 people are killed every year in Europe in more than 1200 accidents occurring at LCs. In this article, we carry out a comparative study involving two main types of Automatic Protection Systems (APS), the first using a pair of half-barriers and the second with four half-barriers. Each of these two automatic protection systems has some relative advantages and some drawbacks. In the literature and in railway and road guidance documents, some recommendations are given in order to make the choice between these systems. However, these recommendations are mainly based on a qualitative analysis.

Here, we suggest some behavioural models that can be used as a basis to assess the collision risk quantitatively on both LC configurations. These Stochastic Petri net (SPN) models describe the global dynamics within the LC area while taking into account both technical aspects and human behaviour. Our models are parameterizable and allow a realistic representation of the dynamics through the LC. Moreover, their simulation gives us a clear idea about the risk level according to various features of the dynamics within the level crossing area.

*Keywords: Railway safety, level crossings, train-car collision, risk-assessment, stochastic Petri net, Simulation*

### 1 Context and Motivations

The number of fatal accidents at Level Crossings (LC) has been significantly increasing over the years. Accidents at level crossings are the result of complex interactions between factors arising from the design and operations of level crossings. Statistics on railway accidents/incidents show how level-crossings are safety-critical. In many European countries, accidents at LCs cause up to 50% of total casualties in railway accidents.

Several types of level crossing protection systems can be used to manage the traffic operation in LC areas. In most LCs with high traffic moment, two main Automatic Protection Systems (APS) are used: 2-half-barrier APS and 4-half-barrier APS. Even though they are very similar, both of them have relative advantages and drawbacks according to the traffic circumstances within the LC area. The choice between them has always been based on a qualitative expertise of LC stakeholders, which may sometimes be quite subjective.

In this paper, we conduct a quantitative risk-analysis study to compare the two automatic protection systems. We aim to appraise which of the two APSs would be more efficient from the safety point of view according to several features of the LC area dynamics that we consider. For the purpose of developing an exploitable description basis of the dynamics in the LC area, Stochastic Petri Nets (SPN) have been used so that the aleatory fluctuations of the various pa-



rameters involved in the dynamics within the LC area, can be depicted precisely. Then, Monte Carlo simulation is carried out in order to appraise the LC collision risk with both investigated APSs and under different circumstances.

The paper is organized as follows: in section 2, we first show the general topology of the LC area. Then, the models depicting the dynamics within the LC area are elaborated and the main relative potential hazards for both APSs studied are examined. The quantitative risk assessment step is detailed in section 3. Finally, in section 4, we review the main contributions and we list the future tasks to be carried out.

## 2 Developing Models of the dynamics through the LC

### 2.1 Topology of the studied LC area

In our study we consider a junction between a unidirectional single track railway line and a bidirectional road. Two kinds of Automatic LC will be studied: Automatic 4-Half-Barrier Level Crossings (4HBLC) – composed of 4 half barriers (2 on each side)- and Automatic 2-Half-Barrier Level Crossings (2HBLC). Together, they formed about two-thirds of the total number of LCs in France in 2006 (vs. 46% in Germany<sup>3</sup>) and are the location of more than 75% of the collisions occurring at French LCs<sup>4</sup> (38% in Germany). Besides the barriers, both LCs are equipped with train sensors, road lights and sound alarms (cf. Figure 1).

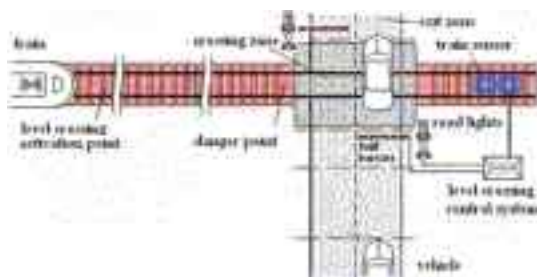

Figure 1 LC Topography.

When a train approaching the LC is detected by the train sensors, the closure cycle is initiated. The LC is reopened to road traffic as soon as the train is detected in the departure direction (also by train sensors).

As announced earlier in the paper, both 4-HBLC and 2-HBLC have advantages and drawbacks. Mainly, two major aspects will be pointed out:

- zigzags: 4-HBLC prevents road users from bypassing the barriers when the LC is closed to road traffic, while zigzagging remains possible with 2-HBLCs. Let us denote this situation risk<sub>1</sub>.
- Traffic jam [1]: Traffic jams are a common phenomenon affecting road users. In the EU, on average, 7,200 km of traffic jams are formed every day. A problem that has caused several train/vehicle collisions at LCs is when a waiting queue is formed in the exit area of the LC. Indeed, it has been shown that, in general, when the LC is open (barriers in the high position and green road lights showing), and when a traffic jam occurs at the LC exit, road users arriving at the LC do not stop before the protection barrier, but enter the LC crossing zone (cz), thus risking remaining blocked on the rail track. Let us denote this situation risk<sub>2</sub>. [4] gives a description of an LC accident due to road traffic queuing in Salisbury-South Australia, which caused 4 deaths and the injury of 26 people in the collision of a train with a bus and a car that were trapped on the track. In France, for instance, on average, this situation is the cause of 10 train-vehicle collisions per year. With 4-HBLC, the vehicle which enters the crossing in the presence of a traffic jam gets



a risky car waiting on CZ can move as soon as the queue ahead moves on. In contrast, with a 4-HB, if the LC is closed to road traffic when the car with the risky behaviour is still on cz, then the car remains trapped on cz because the half-barrier at the LC exit is lowered. On the other hand, zigzagging is only possible with 2-HBs. Below, the model of the road traffic in the direction where there is a potential traffic jam situation is described independently of the protection system used. The differences in the road traffic dynamics, especially the possibility of zigzagging and the consequences of traffic jam formation, according to the LC protection system used will appear when the models of the defined subsystems are integrated.

In the model of Figure 3, P6 and T8 allow vehicle generation, T9 corresponds to entering the crossing zone (cz) and P8 and P9 model position in cz. T9 represents entering the exit zone (EZ) and Places P10, in [1,N] positions in EZ. T12 corresponds to the exit from EZ. P11 initially marked with N tokens -N being the vehicles' capacity of EZ- represents the remaining free places in EZ. Conversely, P12 contains the number of vehicles in EZ and stands for a counter. The traffic jam situation is modelled using the set {P15, P16, T17} and T18. The route in the considered direction is blocked when P16 is marked, which is represented by the inhibitor arc linking P16 to T12. We will adjust the durations associated to T17 and T18 in such a way as to set the proportion of time during which there is a traffic jam situation in the exit zone of the LC. Traffic jam may correspond, for instance, to the situation when some vehicles leaving CZ want to turn left. As they do not have priority, they may block the following vehicles. Also, a traffic jam situation may be caused by road-works on a portion of the route exiting the LC. The normal situation (without traffic jams on EZ) is represented by the upper sequence  $T_9 \rightarrow T_{10} \rightarrow T_{11} \rightarrow T_{12}$ . T9 is enabled only if EZ is not yet saturated. Otherwise, either of the immediate transitions T13 or T15 immediately fires. Conversely, T13 and T15 are enabled only if P11 is empty.

When EZ is saturated [ $M(P_{12}) = N$ ,  $M(P_{11}) = 0$ ], vehicles may behave safely, by waiting until EZ is no longer saturated; this corresponds to sequence  $T_{13} \rightarrow T_{14}$ . However, the vehicle may also adopt a dangerous behaviour while entering cz and incurring the risk of remaining trapped on the crossing zone until an approaching train arrives; this corresponds to sequence  $T_{15} \rightarrow T_{16}$ . Finally, when EZ is saturated, if the vehicle in front of cz decides not to proceed, then the following vehicles cannot advance; this is depicted with the inhibitor arcs linking P13 to T13, P13 to T15, P14 to T13, P14 to T15 and P14 to T9.

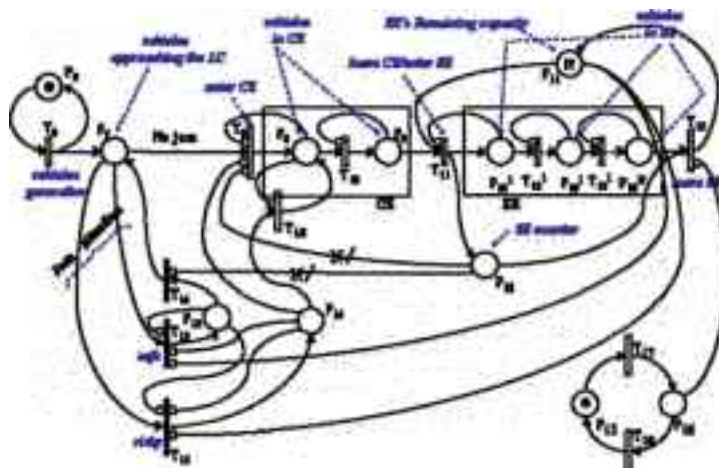

Figure 3 Road traffic model.

### 2.2.3 The LC control system

Here, we propose a quite simplified model of the LC control system dynamics. Two states of the system are considered: open, when the road lights are switched off and the barriers are raised, and closed, when the road lights show red and the barriers lowered (cf. Fig 4). The protection system is supposed to operate safely.

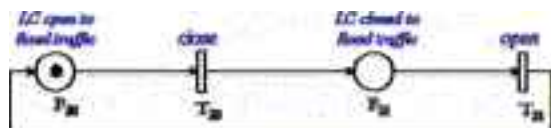

Figure 4 Local control model.

## 3 Risk-assessment

In this section, first the global model describing the dynamics within the LC area is established. This model is obtained by merging the models of the subsystems previously developed. Model integration is done while taking into account the interdependencies between the individual behaviours. Secondly, numerical simulation is proceeded in order to quantitatively assess the risk according to several setups we make. The results are interpreted in order to point out some features relative to 2-HBLC and 4-HBLC.

### 3.1 Representation of the global dynamics within the LC area

Since the LC control system is responsible for managing the traffic within the LC area, it stands for an interface between the railway traffic and the road traffic, and there is no direct interaction between them. Basically, the control system gives absolute priority to the railway traffic whenever a train is approaching.

- between the railway traffic and the control system: independently of the type of protection system used (either 2-HBLC or 4-HBLC), whenever a train is detected by the sensor in the arrival direction, the closure cycle is started and the LC is considered to be closed when the road lights show red and the barriers are lowered, namely 8 seconds later. Conversely, as soon as the train is detected in the departure direction, the LC is reopened to road traffic, that is 5 seconds later. All these interactions are depicted in grey in Figure 5. Namely, two new places are added to our model:  $P_a$  for train arrivals and  $P_d$  for train departures.
- between the control system and the road traffic: the interaction between these subsystems depends on the type of protection system used.

- 1 2-HBLC: with 2-HBLC, as soon as the LC is closed to road traffic, entering CZ becomes prohibited for the arriving vehicles. In case of traffic jams, if some vehicles remain on CZ after the barriers are lowered, they may move as soon as the queue ahead advances. In order to take into account these elements, some modifications (in grey) are made to our models (cf. Figure 5). On the other hand, some undisciplined drivers may incur the risk of crossing CZ by bypassing (zigzag) the half barriers. This will be depicted in mauve. In particular, sequence  $T_{30} \rightarrow T_{31}$  with probability  $prisk_1$  assigned to  $T_{30}$  stands for entering CZ while the 2 half-barriers are lowered. In contrast,  $T_{32} \rightarrow T_{33}$  represents a safe behaviour, which is the one where the arriving vehicle waits until the LC is reopened to road traffic. It should be noted that the model part depicting zigzagging ( $P_{30}, P_{31}, T_{30} \rightarrow T_{33}$ ) is quite similar to the one relative to the vehicles' behaviour in a traffic jam situation ( $P_{13}, P_{14}, T_{13} \rightarrow T_{16}$ ). What is different in the latter is the extra inhibitor arcs emanating from  $P_{13}$ . This expresses the fact that, when the heading vehicle arriving at the LC stops before CZ in traffic jam situation, the following vehicles cannot proceed. On the

contrary, concerning zigzagging, the attitude of the leading vehicle does not influence the behaviour of the following vehicles. In other terms, when the LC is closed to road traffic, whether the leading car decides to zigzag or not, the following vehicles may adopt either a risky or a safe behaviour.

- 2  $4$ -HBLC: with  $4$ -HBLC, as soon as the LC is closed to road traffic, arriving vehicles cannot enter CZ. Moreover, in traffic jam situation, if some vehicles remain on CZ after the barriers are lowered, they cannot proceed, even if the way ahead is clear. This fact is depicted (in blue) in the global model (cf. Figure 5). The part composed of  $P_{21}'$ ,  $T_{20}'$  (deterministic(6)),  $P_{21}''$  and their associated arcs has been added in order to model the fact that,  $4$  seconds after the barrier at the entry of the LC has been lowered, the barrier at the exit side is lowered, thus preventing possible vehicles on CZ from leaving this zone. In contrast to  $2$ -HBLC, zigzagging is not possible when the barriers are lowered. In Figure 5, the mauve part (zigzagging) is specific to the  $2$ -HBLC and the blue inhibitor arc is specific to the  $4$ -HBLC. All the other parts are common for both protection systems. Actually, there are 2 different models, but, for the sake of conciseness, we use one model while pointing out the differences. Here we have chosen temporal parameters relative to an urban LC with a medium traffic moment: one train every 10 minutes and 1 vehicle every 10 seconds, on average. The time characterization has been chosen so as to be quite realistic. For instance, vehicle generation is depicted with a Poisson distribution, whereas train generation is made with a discrete distribution, since the arrival of trains is more regular.

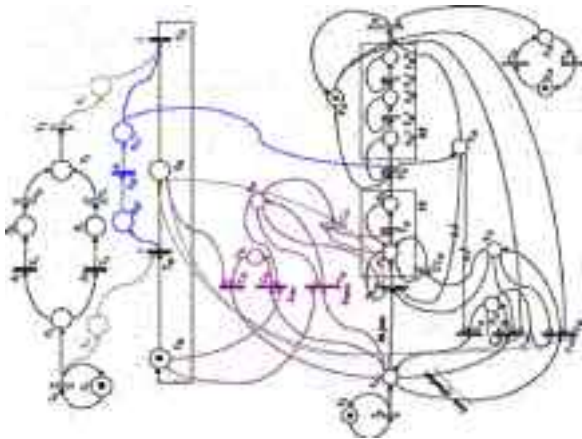

Figure 5 Global model.

### 3.2 Numerical analysis

The numerical analysis is carried out by a Monte-Carlo simulation on the basis of the global model. The impact of the scrutinized parameters (traffic moment, traffic jam length, arrival vehicle rate, etc.) can be assessed by varying the values of these parameters. Note that what is important from the results obtained is not the risk values themselves, since these directly depend on the considered environment parameters, but their variation according to the investigated parameters and for the two APS comparatively to each other.

Finally, the obtained results may help decision makers from the road and railway sides to take appropriate measures in order to decrease the risk by acting on some controllable parameters (intermittent traversing delay for instance).

## 4 Discussions and future works

In this paper, first a general overview on the safety of level crossings throughout Europe and on risk analysis methods in railways is given. Then, a risk assessment study is carried out with the aim of scrutinizing potential dangerous situations according to two distinct configurations of LC automatic control systems.

The main contribution of our study consists in developing a parameterizable model which may serve as a template for risk assessment relative to the main potential hazards discussed beforehand. To our knowledge, this is the first work dealing with this issue. Moreover, it is worth noticing that our model takes into account both railway and road dynamics, but it also considers humans error, which is quite new with regard to existing studies on LC model-based risk assessment. Obviously, the results obtained depend directly on the predetermined parameters of the dynamics, and consequently, the established model has to be adapted to the situation under investigation.

Safety analysis of railway systems involves complex interactions between technological devices, rules and directives, and human behaviour [6]. We intend to deepen our safety analysis investigation on level crossings while exploring different factors impacting LC safety.

## References

- [1] Ghazel M. Using Stochastic Petri Nets for Level-Crossing Collision Risk Assessment. *IEEE Trans on Intelligent Transportation Systems*, 2009; 10(4):668-677.
- [2] Haas PJ. *Stochastic Petri Net Models: Modeling and Simulation*. New York, Springer, 2002.
- [3] Jensen L, Schneider E. *Traffic Control Systems Case Study: Problem Description and a Note on Domain-based Software Specification*, Technical report, Technical University of Braunschweig, 2000.
- [4] RTBU (Rail, Tram & Bus Union Australia), 2002. Available at: <http://www.ema.gov.au/ema/emadisasters.nsf/c85916e930b93d50ca256d050020cb1f/de58544c4a393b37ca256d670004965d?OpenDocument>, Accessed on September 30, 2011.
- [5] El-Koursi EM, Khoudour L, Impastato S, Malavasiand G, Ricci S. *Proceedings of the 2nd workshop 'Technology', SELCAT-Safer European Level Crossing Appraisal and Technology*. Marrakech, INRETS editions, 2007.
- [6] Tey LS, Ferreira L, Wallace A. *Measuring driver responses at railway level crossings*. *Accident Analysis & Prevention Journal*, 2011; 43(6):2134-2141.



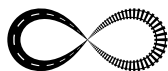

## SAFETY OF TRAFFIC ON RAIL-ROAD CROSSINGS WITH SPECIAL REVIEW OF EU DIRECTIVES ON TRAFFIC SAFETY- PROPOSALS FOR IMPROVEMENTS

Georg–Davor Lisicin, Igor Novačić

*Hrvatski autoklub, Croatia*

### Abstract

Especially dangerous places for traffic participants are crossings of roads and railway lines in level. The consequences of accidents at rail-road crossings are particularly heavy for participants in road traffic and for pedestrians. Construction of infrastructure facilities and management of the interoperability principles are clearly defined in the EU Directives on the safety of traffic in both branches. Integration of experience with the use of modern innovative solutions can significantly reduce the number of accidents, and the analysis of the current state with international experience can describe the current level of traffic safety and direction of research and selection of tools to improve traffic safety at rail-road crossings. Assessment of safety on site and certification as a tool for improving safety should be uniformed and comparable among all EU countries.

*Keywords: rail–road crossings, safety of traffic, accident consequences,  
SELCAT, EU Directives, safety certificates*

### 1 Introduction

Rail-road crossing (hereafter RRC) is the collision point of the railway and road system on which often events or accidents occur with the most severe consequences and fatal or serious injuries. In traffic accidents at RRC's, the casualties are mostly road traffic participants and their property is destroyed, although in accidents involving heavy motor vehicles (trucks) there are often serious casualties of railway passengers and workers along with major damage to rolling stock. The conducted analysis of traffic accidents sample on RRC's point to the conclusion that drivers of road motor vehicles and other participants in road traffic (pedestrians and cyclists) are mostly responsible for causing an accident. Because of these reasons, along with traffic-technical and dynamic features of the railway system and the great stopping length of the train it is necessary to observe the problem from the viewpoint of road users and drivers. It is useful to use international experience, particularly the conclusions of the project SELCAT (Safer European Level Crossing Appraisal and Technology), with the primary objective and purpose of harmonizing approaches to solve this specific problem. SELCAT is a European Commission (hereafter EC) programme for the analysis of safety conditions on RRC's, which includes 24 partners from 9 European countries, along with Japan, China, India, Morocco and Russia.



## 2 Rail-road crossings safety analysis

**Table 1** The railway network in Republic of Croatia (hereafter RC) in 2010, had total length of 2976 km on which there were 1514 RRC (pedestrian crossings included) in level. To illustrate dynamics of solving solutions with elimination an overview is given in Table 1 with data from the period 2005 – 2007. Number of RRC in accordance with security measures and railway importance (HŽ – infrastructure, [6], [12], [15])

Year		2005	2006	2007	2010
International railway (I)	Traffic Sign+ Visibility Triangle	329	320	307	272
	Barrier automatic/mechanic	282	292	309	330
	Total	611	612	616	602
Regional railway (R)	Traffic Sign+ Visibility Triangle	296	297	289	281
	Barrier automatic/mechanic	114	114	114	125
	Total	410	411	403	406
Local railway (L)	Traffic Sign+ Visibility Triangle	471	463	459	433
	Barrier automatic/mechanic	62	60	64	73
	Total	533	523	523	506
Altogether		1554	1546	1542	1514

Safety risk indicator is defined with the density of the RRC in level in relation to the length of the rail network. In Republic of Croatia, it is 0.55 RRC / km which is approximately the density of the RRC in Germany, worse than the density in the UK, but more favourable than the density of the new EU members. (Table 2)

**Table 2** Number of RRC per km of railroad (HŽ – infrastructure, [6], [12],[15])

Country	RCC	Km of railway	RCC / km
Germany	21416	37958	0,56
Poland	18517	19599	0,94
Czech Republic	8448	9513	0,89
France	19133	29286	0,65
United Kingdom	7485	16208	0,46
Republic of Croatia	1514	2976	0,50

### 2.1 Methods of rail-road crossing security measures

In further analysis of the current situation, we can say that in the RC all rail-road crossings are managed in a lawful manner, which includes ensuring road traffic signs and visibility triangle (hereafter TS+VT) or technical security devices: light-sound device (hereafter referred to LI+SO), then LI+SO with half-barriers (hereafter LI +SO+HB), mechanical (half-barriers + guards) or automatic, as well as solution in two levels (denivelation). From the total number of RRC's on HŽ railroads (1514), 986 RCC's or 65.13% are secured with the TS+VT method. Adverse state of security still exists in nearly 70% of RRC's, of rail and road transport, and it has effect on living and working conditions in local community, further development of the transport system, spatial planning and economic activity where the security of road transport is carried out only with TS+VT especially at the local level. This situation requires continuous systematic measures in finding appropriate technical - technological solutions and an increase in traffic discipline, and traffic culture of the drivers. Due to this fact in 2006th The Program of solving rail-road crossings in Republic of Croatia was adopted (futher PRZCPRH) [5]. The program planned activities and measures: visibility triangle arrangement (VT), the elimination and reduction to the adjacent RRC, elimination without reducing , additional half-barriers to devices, installation

of a light-sound device (Li+ SO), installation of a light-sound device with half-barriers (Li+SO +HB) in the period until 2015., and level denivelations that should be completed by year 2020. In the National program [6] it is particularly emphasized that the RRC are neuralgic points in the railway system because most accidents happen there, with the largest number of victims. Solution should respect the PRZCPRH, and ultimately on all remaining RRC's additional safety devices should be installed. Inadequate dynamics of PRZCPRH implementation, among other things, is probably caused by the fact that there is some inconsistency with the 'Program of construction and maintenance of public roads' that were not foreseen or provided sufficient financial resources for successful implementation of PRZCPRH, which should be adjusted in the next period (2012- 2015). This situation requires promotion of the new and partially revised approach in solving this serious problem which involves the analysis of problems and conditions from the point of view of road users. It should be made by synergistic action of all relevant parties and stakeholders responsible for improving the situation. Major role in Croatia should be given to the recently founded Agency of Railway Safety (Act of AZP, Official Gazette 120/08) and the European Agency for road safety on the EU level [10].

## 2.2 Safety of traffic on rail-road crossings

Traffic safety at the RRC's, as specific intersection places of the railway and road infrastructure, and collision places of the rail and road traffic, should be monitored by the appropriate service in accordance with their legal responsibilities and obligations. Accordingly, in the event of an accident at the RRC in which a person is injured or property damaged police officers perform the investigation. In addition to the standard procedure, the EU Action Plan 2011 - 2020 [14] and the Directive on the management and road safety [9] require active and standardized methods and specific proposals for the elimination of any shortcomings in the areas of traffic accidents. Directive on railway safety in Chapter v, on the other hand also requires the need for an investigation and making safety recommendations, particularly in the case of severe accidents with fatalities [10] . By analyzing data from the Bulletin of safety in road traffic from the Ministry of internal affairs (further MUP) on traffic accidents in the RRC and its consequences in the past decade, in total there are 508 train collision recorded, with an average of 72.5 collisions per year, with a total of 71 persons killed, 98 seriously injured and 209 injured people (Table 3), or an average of 65 collisions with a train.

**Table 3** Number of traffic accident-collisions with a train and consequences (Bulletin of the MUP [7])

Year	Number of traffic accident-collision with a train				Consequences of traffic accidents in total		
	Collision with a train	Casualties	Persons died	Injured persons	Persons died	Seriously injured	Less injured
2001	66	28	6	22	7	12	23
2002	72	37	11	26	11	15	26
2003	63	31	6	25	7	11	29
2004	62	28	9	19	11	15	34
2005	87	38	7	31	11	18	34
2006	84	43	15	28	17	18	23
2007	74	31	4	27	7	9	40
2008	44	25	6	19	8	12	20
2009	68	33	9	24	11	13	22
2010	37	19	4	15	6	6	13

### 2.3 Traffic accidents on rail-road crossings, related with the means of protection

The total number of traffic accidents on RRC's, by type of protection for the period 2001–2010 is presented in Table 4, which also includes those accidents in which there was no collision with a train.

**Table 4** The total number of traffic accidents by type of RRC protection (Bulletin of the MUP) [7]

Protection of RRC	LI+SO+HB	LI+SO	'Unprotected' (TS+VT)	Total
Year 2001	243	109	226	578
2002	250	99	181	530
2003	290	107	120	517
2004	283	87	117	487
2005	274	80	100	454
2006	311	91	94	496
2007	303	96	115	514
2008	253	94	68	415
2009	305	88	69	462
2010	278	80	51	409
Total	2790	931	1141	4862

It is important to emphasize that in relation with the type of protection, all RRC's in RC are protected, so we can conclude that in the Bulletin of the MUP [7] the term 'unprotected' in fact refers to RRC's protected with only LI+SO or LI+SO+HB. The analysis of the total number of traffic accidents on RRC's with casualties, in relation with the method of protection, in the past decade shows that 218 (28.9%) occurred on physically protected RRC's LI+SO+HB, 132 (17.5%) on RRC's protected only with the LI+SO, and 406 (53.7%) accidents have been recorded on the RRC secured with only TS+VT ('unprotected') as shown in the Figure 1.

**Structure of traffic accidents on RRC with casualties in relation to method of protection**

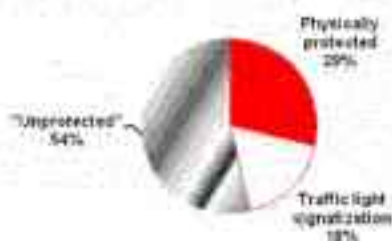

**Figure 1** Structure of traffic accidents on RRC with casualties in relation to method of protection (Bulletin of the MUP) [7]

### 2.4 Consequences of traffic accidents on the RRC's

Despite detailed analysis of traffic accidents provided by MUP, we must emphasize the need for realistic parameters, and comparable evaluation of absolute and relative data in relation with the number of traffic accidents and casualties and average annual daily traffic (PCU / day) of vehicles that had passed through RRC particular in relation to train kilometres (train km = relative indicator of railroads). Croatian railways (further HŽ) divide extraordinary events (emergencies) on accident, misfortunes and nuisance. The analysis of the condition of traffic safety on RRC follows an extraordinary event with killed and seriously injured people, bigger

material damage, or longer interruption of traffic and severe pollution of the environment. HŽ doesn't register minor injuries, mainly due to usually severe consequences of accidents. Methodology for monitoring the consequences of accidents harmonized with the EU directive [10] observes even avoided accidents, or improper passing railroad cars across the RRC, as well as irregular passages of cars and pedestrians. This methodology uses the comparison of the total number of accidents in road traffic and the total number of traffic accidents on the RRC, and compares the total number of people killed in road traffic and the total number of people killed on the RRC in the observed period (Table 5).

**Table 5** The ratio of traffic accidents (TA) on the RRC in the total number of traffic accidents ( Bulletin of MUP - Table 5)

Year	2001	2002	2003	2004	2005	2006	2007	2008	2009	2010	Total
TA	81911	86611	92102	76540	58132	58283	61020	53496	50388	44394	662877
TA on RRC	578	530	517	487	454	496	514	415	462	409	4862
Ratio (%)	0,706	0,612	0,561	0,636	0,781	0,851	0,842	0,776	0,917	0,921	0,733

Traffic accidents on the RRC in the RC, are 0733% of the total number of accidents in road traffic, which is several times higher than in EU countries where the average number of such accidents is around 0.01%.

## 2.5 Safety aspects of the RRC's usage with evaluation

As previously presented, the largest number of accidents on the RRC in the past decade occurred on physically protected RRC's (2790 - 57%), while twice as many road accidents (1141 - 24%) are recorded on the "unprotected" RRC's that are not necessarily the most dangerous ones (Table 4). We have recorded that the total number of people killed in the last decade in RC is; 5530 people killed in road transport [7] (p. 80) and a total of 92 persons killed in traffic accidents on the RRC [7] (p. 84) and the proportion of the total number of people killed is 1,664%, which is also a much higher number than in EU countries where the average ratio is below 1% [11]. With long term monitoring and analysis of road traffic at RRC, we noticed an inadequate and improper treatment of participants in road traffic (motorists, bicyclists, pedestrians) and risky manner of the RRC usage and improper crossing of railroad tracks along the worrying trend of increasing accident number at crossings with the highest degree of security and about 550 collisions and fractures of half-barriers annually. This fact confirms the need for systematic training of participants of road traffic on the correct railway line crossing, with the use of repressive measures for contempt of signalling and evasion of half-barriers. Unacceptable form of behaviour of participants in road traffic and violations are often caused by the following reasons and circumstances: insufficient knowledge and perception of the level and types of risk of using RRC's, drivers and pedestrians often have wrong assessment of a sufficient time to cross the railway line before the arrival of the train and they are accepting an improper collateral risk of crossing; Insufficient education and knowledge of proper usage of RRC and understanding of traffic situation and signals due to low frequentation of RRC usage (only several times a year or less); disorientation in certain specific traffic situations, inadequate transport and technical requirements for the safe use of the RRC, the growth of vegetation or newly build objects are often reducing vt on RRC's that are secured only with TS, then inappropriately placed road traffic signs, and the unacceptably long closure time of RRC for participants in road traffic. The current scope and method of solving the problem with PRZCPRH [5], or the National Railway Infrastructure Programme [6], as previously presented traffic safety indicators at the RRC's are showing the unsatisfactory conditions.

### 3 International experience – EU Directives and guidelines

Every year, in the EU, on average, more than 1200 accidents occur at RRC where every year 330 persons are killed, which shows the social importance and complexity of the problem of traffic safety on the RRC. Precisely because of this fact a research project 'SELCAT' has been launched. It is a consortium of 24 partners from railway and road sectors, professional institutions and scientific institutions of the EU, Japan, China, India, Morocco and Russia. The project 'SELCAT' carried out the collection of relevant data for the safety of traffic on the RRC, and has published an analysis of the current situation (3.1). In accordance with the EU Directive on the safety of road transport infrastructure [9] it is necessary to audit even an early stage in the planning of each RRC and incorporate the audit tools during building and experience of the 'best' practices. Railway Safety Directive [10] on the other hand also determines the general safety standards and the establishment of model certificates, with periodic audits. With the combination of directives we can form a parallel system with identical guidelines, which can access the system by forming a single audit, security assessment and problem solving on an individual RRC's from the standpoint of both branches.

#### 3.1 SELCAT project

The 'SELCAT' was launched with the support of the European Commission (EC) and with the participation of ADAC (German Automobile Club), which did an extensive research on the safety of traffic on the RRC in Germany with emphasis on use by road traffic participants. Based on the research conducted the following conclusions and assessments of the current situation is: on the RRC's the highest mortality rate from all the European railways was recorded, about 50-80% of all rail accidents (emergencies); altogether with tunnels, specific high-risk areas ("black points") certain sections of roads and rail infrastructure, the RRC's represent a serious safety issue; Despite the ratification of the Vienna Convention on Road Signs from 1968. by the EU Member States and EC, there is an unevenness of regulations and safety systems that ensure the safety of traffic on the RRC, which implies the necessity of their unification and harmonization at a European level; inadequate VT at a number of RRC, which are not provided with LI+SO, but only with appropriate traffic signs (A49 or A50) 'Andrew's cross' and a STOP sign (Bo2); disparity of data structures and methodologies and ways of monitoring the safety of traffic on the RRC was determined, which further complicates and impedes uniformity and data comparison (police, road operators, railways); there is no common database and common information system on accidents at the RRC's in level; the awareness and education of drivers about relevant regulations and functioning of RRC's safety systems has been insufficient; the behaviour of participants in road traffic is dangerous, which mostly happens by accident, and in a smaller number of cases deliberately (Figure 2).

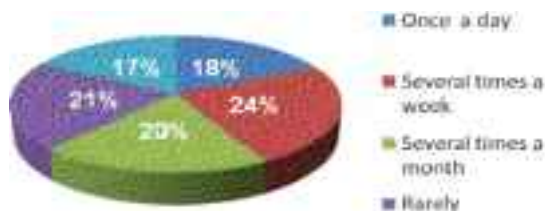

**Figure 2** Schematic representation of hazardous behaviour of road traffic participants, Schlag, Fischer, RoBger, TU Dresden, [11]

With conducted extensive research of the reasons and factors that influence the behaviour of participants to make unintentional mistakes in road traffic we came to the realization that it is also conditional upon the following circumstances:

### 3.1.1 RRC`s usage frequency

Only 18% of road traffic participants use the RRC level on a daily basis while 58% use the RRC`s only a few times a month or less (Figure 3).



**Figure 3** Frequency of RRC`s usage by road participants [11]

Occasional and rare usage of the RRC has resulted in a reduced routine adoption of subconscious patterns of behaviour as opposed to the road intersection with traffic lights that are used daily. It is necessary to bear in mind that the RRC`s are places where complex rules and security systems apply, more then at the regular intersections. For enhancing security of the RRC`s it was suggested that instead of blinking red lights we should use steady red lights like at road intersections, because of the driver routine behaviour (3.1.3).

### 3.1.2 Driver insecurity on an RRC`s without technical-safety systems

A survey of driver and pedestrian attitudes (Figure 5) shows that more than 50% of participants in road traffic at RRC crossings secured only with the TS + VT feel unsafe, which may adversely affect the acquired forms of routine behaviour, or result in inappropriate reactions.

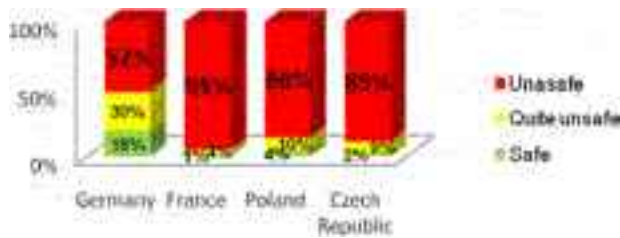

Figure 4 Driver insecurity on RRC`s without technical-safety systems [11]

### 3.1.3 Misrepresentation of blinking red traffic lights

Blinking red light at the RRC in the level of the signal indicates the term 'Stop' and announces the arrival of the train, which is known to only 57% of surveyed drivers and a high 39% thought that it means 'warning', and that only a steady red light means 'STOP' (Figure 5). This is a result of a routine behaviour adopted at road intersections. This knowledge also indicates the need for changes in regulations and redesigning the RRC in a way to be 'self'–explanatory'. Deliberately dangerous behaviour can be judged as inappropriate behaviour (inappropriate speed), and routine violations.

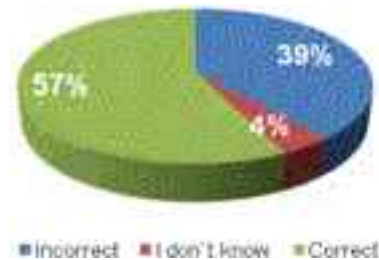

Figure 5 Interpreting the meaning of blinking red lights at the RRC`s [11]

One of the most frequent forms of dangerous behaviour that can be placed in a group of routine offenses is certainly a 'slalom run' (crossing over RRC`s, which are secured by Li+ SO+HB at the time when LI+SO devices are activated, and half-barriers lowered), which is often the result of RRC excessive periods of closure for road traffic. Red phase in road traffic is usually changed to green after 90 seconds (maximum duration), but some RRC`s can be closed to road traffic for up to 10 minutes, or even several times per 10 minutes in one hour (eg. RRC 'Rade Koncar' and 'Krčeni put' in RC). Here, mostly local drivers who daily use this RRC, practice a 'slalom run', and outstrip vehicles waiting at the crossing of the RRC knowingly accepting an increased security risk as collateral, and often 'withdraw' the other drivers behind them.

## 4 Options and ways of improvement

According to the ratio of traffic accidents and people killed on the RRC's in the total number of traffic accidents and fatalities in road traffic in RC (2.5) we can conclude that the current state of traffic safety at the RRC is unsatisfactory, and there is a need to undertake and implement series of measures and activities to improve the situation.

### 4.1 The framework for a multidisciplinary approach

First we need to do a mutual research and safety assessment of the RRC's (4.2) from the standpoint and with the help of experts from both branches. Then it is necessary to conduct the study of participant attitudes on RRC road traffic in RC. It is also necessary to prepare a revised and harmonized PRZCPRH for the period from 2012 - 2020. By carrying out activities on the standardization of regulations and their harmonization with EU regulations, preconditions for the successful integration of Croatian Railways in the trans-European rail network can be achieved, as well as the achievement of strategic objectives (3). There is an obligation to resolve the issue of certification of equipment and devices as well as the entire RRC and establish a unified database on road accidents and their consequences on the RRC's. It is essential to adopt new technologies and develop alternative design of roads, and enable faster and more effective implementation of administrative and management procedures for obtaining construction permits to perform a procedure for solving the RRC's. An extensive campaign should be launched with the goal to enhance education on regulations, proper behaviour, and knowledge about the dangers and risks of using RRC's for all those involved in road traffic.

### 4.2 Rail-road crossings safety assessment programme

According to the guidelines and directives of the EU [9], [10] and [13] we suggest the establishment of an international security assessment, which could be implemented within the already widely accepted EuroTest programme, which has produced very good results in road traffic and has a constant media attention of nearly 120 million Europeans. Testing methodology would be based on parameters that define the safety from the perspective of all RRC users, the machinist, the driver and the pedestrian. Nearly three hundred security parameters would be grouped into categories and evaluated with the help of the Analytic Hierarchy Process method [16]. The 'knockout' system of scoring would be used on a group of parameters (if one of the key parameters is evaluated negatively the whole group gets a lower grade). Along with safety assessment and evaluation on the field, modification factors would be applied in terms of level safety potential and security risk degree coefficients. The safety potential coefficient refers to innovative methods and solutions to reduce the consequences of accidents (safety systems on the vehicle, train or car, modern light signalling, advanced control systems, etc.) and security risk degree coefficient would be calculated from assessment based on analysis of accidents and serious incidents (close encounters and fractures of half-barriers). The parameters would be grouped in following categories with relative proportions of the total score given according to the importance: spatial and temporal design of the RRC (39%) - assessment of the spatial design and technical performance of the crossing, road and railway alignment, built-in materials and state of infrastructure, phases of traffic light signals and crossing signalization design as well as approach signs (traffic signs, 'Andrew's Cross'). Possible intersections and the synchronization of the traffic light before and after RCC would also be taken into account; daylight visibility (20%) - evaluation of  $vT$  from the standpoint of the machinist, driver and pedestrian in the daytime visibility conditions documented with photos and the georeferenced video from road vehicle; night time visibility (23%) - same test conducted in night time condition. Improved lighting systems and the application of modern



solutions for light signalling can contribute to a better overall score in this two visibility categories; accessibility (18%) - accessibility and assessment of the importance of RCC on the road network (reducing the importance of RCC in the network by redirecting or reducing two or more RCC's to one). Here, attention is specially drawn to the accessibility for all groups of pedestrians and persons with limited mobility and reduced perception (people with disabilities in a wheelchair, blind or visually impaired and deaf or hard of hearing). In this category the use of modern innovative signalling solutions would be calculated (counting phase, the LED lights) and pedestrians would be directed how to prevent improper crossings. Enormous importance of periodic testing from the standpoint of the consumer is set by the EU directives and guidelines [9], [10], [13] and [14], where as a tool they recommend implementation of the international comparable tests. The proposal for the certification of the RCC's, proceeds from the need to raise awareness of public about the problem, and in order to force the legislators and operators to make concrete measures on site. After the testing and certification an international large-scale media campaign would be launched.

## References

- [1] Zakon o željeznici, Zagreb, Narodne Novine br. 123/03, 30/04, 153/05 i 79/07
- [2] Zakon o sigurnosti u željezničkom prometu, Zagreb, Narodne Novine, br. 40/07
- [3] Zakon o sigurnosti prometa na cestama, Zagreb, Narodne Novine, br. 67/08
- [4] Lisicin D.G.: Analiza stanja sigurnosti na željezničko cestovnim prijelazima u RH, Hrvatski autoklub, Zagreb, 2008.
- [5] Program rješavanja željezničko-cestovnih prijelaza u RH, MMTPR, Zagreb 2006.
- [6] Nacionalni program željezničke infrastrukture 2008. – 2012. Godine, Zagreb, 2008. Narodne Novine br. 31/08
- [7] Ministarstvo unutarnjih poslova RH, Bilten o sigurnosti cestovnog prometa 2010., Zagreb, 2011., ISSN 1331-2863
- [8] ADAC, Schiene-Kreuzungen aus der Sicht des Fahrers, Munchen, 2008.
- [9] Directive 2008/96/EC on road infrastructure safety management, Strasbourg, 2008.
- [10] Directive 2004/49/EC - Railway Safety Directive, Strasbourg, 2004.
- [11] Projekt SELCAT, ITSAE, TU Braunschweig, <http://www.iva.ing.tu-bs.de/levelcrossing/selcat/> , 15.03.2012.
- [12] Željezničko cestovni prijelazi u Hrvatskoj, Hrvatske željeznice, <http://www.hznet.hr/18> , 15.03.2011.
- [13] European Commission, Transport › Rail › Interoperability & safety, [http://ec.europa.eu/transport/rail/interoperability/interoperability\\_safety\\_en.htm](http://ec.europa.eu/transport/rail/interoperability/interoperability_safety_en.htm), 15.02.2012.,
- [14] EC, Towards a European road safety area: policy orientations on road safety 2011-2020, Brussels, 2010.
- [15] HŽ Infrastruktura, Izvješće o stanju sigurnosti u željezničkom prometu HŽ Infrastrukture za 2010. godinu, Zagreb, 2011.
- [16] T. L. Saaty, Models, Methods, Concepts & Applications of the Analytic Hierarchy Process, Pittsburgh, 2001.

## AUTHOR INDEX

Ahac, Maja.....	657, 665	Cherkaoui, Abdelghani.....	1093
Ahac, Saša.....	751	Ciuffini, Francesca.....	161
Albinović, Sanjin.....	649	Coiret, Alex.....	693
Alduk, Waldemar.....	509	Cuculić, Marijana.....	273, 997
Amante, Andrea.....	547	Časnocha, Peter.....	405
Andraši, Nikola.....	733	Čygas, Donatas.....	357
Anton, Valentin.....	945	Ćirilović, Jelena.....	389
Aronsson, Martin.....	823	Ćirović, Goran.....	539
Asdrubali, Francesco.....	169	Dahlberg, Hans.....	823
Atanasova, Vaska.....	907	D'Alessandro, Francesco.....	169
Atmadzhova, Dobrinka.....	1059	Damaziak, Krzysztof.....	709
Babić, Sergije.....	273, 997	Damjanovic, Jasmina.....	455
Bačić, Mario.....	797	De Chiara, Francesca.....	625
De Baets, Koen.....	75	Dekoninck, Luc.....	757
Balagić, Inđa.....	875	Deloukas, Alexandros.....	587
Baričević, Ana.....	675, 701	Deluka–Tibljaš, Aleksandra.....	273, 997
Barišić, Ivana.....	461	Denona, Željko.....	1085
Barnat, Wiesław.....	1041	Despotović, Iva.....	477
Basbas, Socrates.....	203, 565	Dicu, Mihai.....	397, 945
Bašelj, Roman.....	327	Dimitrov, Emil.....	1059
Baudyš, Karel.....	869	Dimter, Sanja.....	59, 461, 509
Bekić, Damir.....	499	Dobrica, Tomislav.....	229
Berger, Wolfgang Josef.....	141	Dolaček–Alduk, Zlata.....	59, 509, 517
Bjegović, Dubravka.....	675, 701	Domitrovic, Josipa.....	267
Bojović, Nebojša.....	533	Dragčević, Vesna.....	751, 1117
Borza, Viktor.....	831	Duvnjak, Ivan.....	665
Bosquet, Romain.....	693	Džambas, Tamara.....	665
Bos, Simon C.....	727	Eger, Rudolf.....	961
Botteldooren, Dick.....	757	Eliou, Nikolaos.....	1109
Branković, Vladan.....	609	Ferreira, Adelino.....	243
Bratka, Milos.....	491	Földiák, János.....	831
Brčić, Davor.....	929, 981	Fontul, Simona.....	625
Brezina, Tadej.....	915, 953	Forsgren, Malin.....	823
Brumec, Uroš.....	185	Fortunato, Eduardo.....	625
Bruton, Gillian.....	499	Frey, Harald.....	915
Bucher, Roland.....	805	Fujiu, Makoto.....	81
Budimir, Vjekoslav.....	805	Gailiené, Inesa.....	1139
Buratti, Cinzia.....	169	Gaspar, Laszlo.....	25
Burlacu, Adrian.....	281, 287, 397	Gasser, Florian.....	683
Burlacu, Alina.....	945		
Bušelić, Ljerka.....	781		
Carbonneau, X.....	309		
Chatziparaskeva, Martha.....	891		

Gavin, Kenneth	429	Kraljić, Tomislav	213
Gestrelus, Sara	823	Kralj, Stjepan	523, 633
Ghasemi, Hamid	439	Krason, Wieslaw	709, 1041
Ghazel, Mohamed	1151	Kubo, Pablo Yugo Yoshiura	237
Gillis, Dominique	757	Kulpa, Tomasz	89
Gjetvaj, Verica	781	Lajčaková, Gabriela	719
Glavinov, Aleksandar	195, 557	Lakušić, S.	665, 657, 675, 701, 733, 1129
Gocálová, Zuzana	1013	Laurinavičius, Alfredas	357
Gorkem, Cagri	343	Lauš, Denis	847
Graf, Hans-Christian	133	Lauwers, Dirk	757, 221
Grdić, Zoran	477	Layerle, Eric	413
Gritti, Silvano Paolo	547	Lazăr, Ștefan Marian	397
Gucunski, Nenad	439	Lemmerer, Helmut	953
Haladin, Ivo	657, 665, 675, 701, 733	Librić, Lovorka	789
Hand, Stephen	499	Lisicín, Georg-Davor	1159
Hauser, Jaroslav	373	Livneh, Moshe	765
Hebib-Albinović, Mirna	649	Longo, Giovanni	97, 105
Heinicke, Franziska	421	Lubineau, F.	309
Hoić, Marko	1147	Ljevo, Dženet	815
Hruzikova, Miroslava	641	Ljubaj, Ivica	841
Huzjan, Boris	745, 1085	Macura, Dragana	533
Ibesich, Nikolaus	953	Madejski, Janusz	1067
Janoš, Vít	869	Maher, Ali	439
Jukić, Ante	733	Majstorović, Igor	937, 969
Jullien, Agnès	693	Mamčić, Stanislav	1077
Jurecka, Katalin	67, 579	Manes, Armando	547
Jurkaš Marković, Kristina	317	Marčić, Danijela	797
Kaba, Faruk Jusuf	177	Marković, Ljubo	539
Kamlesh, Govind	625	Markovik, Lidija	907
Karcher, Carsten	301	Matković, Tatjana	1085
Kazda, Antonín	595	Mayerthaler, Anna	915
Kehagia, Fotini	1051	McKeogh, Eamon	499
Kerin, Igor	499	Medeossi, Giorgio	97, 105
Keser, Igor	1147	Medved, Mario	413
Kleizienė, Rita	357	Melcer, Jozef	719
Klementsitz, Roman	883	Merkun, Aleš	185
Klug, Brigitte	683	Michaut, Jean Paul	309, 739
Ključarić, Marijan	899	Mikolaj, Ján	405
Knez, Martin	773	Milić Marković, Ljiljana	539
Knežević, Nikola	533	Milovanovic, Bojan	267
Kolarić, Ivan	413	Miltiadou, Marios	203, 565
Kolić, Davorin	989	Mintsis, George	203, 565
Korlaet, Željko	229, 1117	Mirčeta, Antonia	789
El Kursi, El Miloudi	1093	Misokefalou, Eleni	1109
Kovačević, Meho Saša	789, 797	Mitkovska-Trendova, Katerina	195, 557
Kozamernik, Mitja	327	Mladenović, Goran	389
Kozumplikova, Alice	373	Mlinarić, Tomislav Josip	841, 847, 875
Krakutovski, Zoran	115, 195, 557, 923	Moges, Mizan	301
		Moretti, Elisa	169
		Moser, Vladimir	461

Moslavac, Darko .....	115	Ristić, Nenad .....	477
Moutchou, Fatiha .....	1093	Rüger, Bernhard .....	133, 1019, 1027
Mrozek, Michal .....	491	Rukavina, Tatjana .....	259, 267
Mturi, Georges A. J. ....	335	Salajka, Vlastislav .....	491
Muzik, Juraj .....	1013	Santos, João .....	243
Nenov, Nencho .....	1059	Schiavoni, Samuele .....	169
Nicodème, Christophe .....	45	Schöbel, Andreas .....	485, 815
Niegl, Martin .....	953	Sengoz, Burak .....	343
Niezgoda, Tadeusz .....	709, 1041	Serdar, Marijana .....	701
Nkgapele, Matsopole .....	335	Sevelova, Lenka .....	373
Novačić, Igor .....	1159	Shala, Fitim .....	123
Nowacki, Gabriel .....	149	Simić, Goran .....	1019
Nuhodžić, Rešad .....	533	Simić, Tatjana .....	617
Njegovec, Mario .....	1005, 969	Simroth, Axel .....	421
Ocelić Bulatović, Vesna .....	317	Sitongia, Giulio Rocco .....	161
O'Connell, Johan .....	335	Sivilevičius, Henrikas .....	1077
Ognjenović, Slobodan .....	195, 557	Skerys, Kęstutis .....	1139
Onsori, Amir .....	343	Slabe, Tadej .....	773
Opačić, Nebojša .....	213	Stadkowski, Aleksander .....	155
Padoano, Elio .....	105	Slavulj, Marko .....	929
de Paiva, Cassio Eduardo Lima .....	237, 365	Smith, Roderick A. ....	35
Pakkala, Pekka .....	383	Smutny, Jaroslav .....	641
Papaioannou, Panagiotis .....	587	Sporčić, Velimir .....	429
Pavšek, Aleš .....	601	Stadlmann, Burkhard .....	133
Pepucha, Lubomír .....	405, 1013	Stančerić, Ivica .....	229, 1117
Persaud, Bhagwant .....	1101	Steckler, Paul .....	683
Pešut, Sanjin–Velebit .....	745	Stefanović, Igor .....	455
Petcu, Claudia .....	295, 397	Stefunkova, Silvia .....	351
Petraschek, Thomas .....	469	Stepanov, Stanislav Alexandrovich .....	575
Pfaffenbichler, Paul .....	915	Stepan, Željko .....	937, 1005
Pilko, Hrvoje .....	899, 981	Stipanović Oslaković, Irina .....	429, 633
Piplica, Petar .....	733	Stober, Dina .....	517
Plasek, Otto .....	491, 641	Strineka, Andrea .....	259
Pleša, Tihomir .....	841, 875	Sugiyama, Shigeki .....	81
Politis, Ioannis .....	587	Svoboda, Richard .....	641
Pološki, Damir .....	937	Šemrov, Darja .....	601
Puž, Goran .....	429	Šestáková, Janka .....	1013
Pyrgidis, Christos .....	891, 1051	Šimun, Miroslav .....	259
Queiroz, Cesar .....	389	Šimunović, Ljupko .....	929
Răcănel, Carmen .....	281, 287, 295, 397	Šubić, Nikola .....	981
Ramūnas, Vaidas .....	1139	Šurdonja, Sanja .....	273, 997
Rek, Vesna .....	317	Tadei, Roberto .....	421
Remek, Luboš .....	405	Takada, Kazuyuki .....	81
Ressel, Wolfram .....	251, 1033	Talvitie, Antti .....	383
Ricci, Stefano .....	161	Taxiltaris, Christos .....	203, 565
Riessberger, Klaus .....	19	Tejkl, Kai .....	1033
Rigo, Ana .....	1005, 969	Tepeš, Krunoslav .....	899
		Tkalčević Lakušić, Višnja .....	1129
		Tomičić–Torklavić, Mirjana .....	609

Topal, Ali .....	343
Topličić–Ćurčić, Gordana .....	477
Trentin, Leandro Cardoso .....	365
Tsakirpoulou, Anthi .....	203, 565
Turk, Goran .....	327
Tušar, Marjan .....	327
Twardoch, Grzegorz .....	155
Urbain, Jean–Etienne .....	413
Uttenthaler, Helmut .....	863
Vaitkus, Audrius .....	357
Vajdić, Marko .....	429, 633
Vajdić, Nevena .....	389
Vandanjon, Pierre–Olivier .....	693
Vavricka, Jiri .....	351
Vek, Danilo .....	485
Vilić, Melkior .....	847
Villim, Andrej .....	1013
Vorobjovas, Viktoras .....	357
Vougioukas, Manos .....	587
Vucetic–Abinun, Slavica .....	447
Walter, Stefan .....	855
Watson, Robert .....	35
Wehr, Werner .....	683
Weise, Markus .....	251
Wendeler, Corinna .....	805
Yvinec, B. ....	309
Zafirovski, Zlatko .....	115
Zak, Josef .....	351
Zavrtanik, Nataša .....	327
Zemljič, Franc .....	601
Zhou, Jing .....	35



Proceedings of the  
2<sup>nd</sup> International Conference on Road and Rail Infrastructure – CETRA 2012  
7–9 May 2012, Dubrovnik, Croatia

KEYNOTE LECTURES

EDUCATION

TRAFFIC PLANNING AND MODELLING

INFRASTRUCTURE PROJECTS

INFRASTRUCTURE MANAGEMENT

ROAD INFRASTRUCTURE PLANNING

ROAD PAVEMENT

ROAD MAINTENANCE

STRUCTURES AND STRUCTURAL MONITORING

RAIL INFRASTRUCTURE PLANNING

RAIL TRACK STRUCTURE

INNOVATION AND NEW TECHNOLOGY

ENVIRONMENTAL PROTECTION

GEOTECHNICS

INTEGRATED TIMETABLES

URBAN TRANSPORT PLANNING AND MODELLING

URBAN TRANSPORT INFRASTRUCTURE

VEHICLES

TRAFFIC SAFETY

